



Korean War British FV18001 Mk. 1 80in 1/4 Ton 4x4 Utility Vehicle (Early Production) / 10-cwt Bantam Trailer

1/35 SCALE

35GM0076

English

After WW2 the Rover Car company in the UK began work on a 4x4 agricultural vehicle to sell to farmers to raise money for future saloon car development. By 1948 a 1/4ton 4x4 Utility Vehicle had emerged with a bodywork made of war surplus aluminum rather than steel. It featured a simple Dog Clutch to switch from 4x2 to 4x4 drive depending on the road conditions. Its use of many commercial parts also reduced the unit price to almost half that of its rivals. Though the British army had several similar vehicles already under development, a small batch of the Rover Utility cars was ordered in 1949, later designated the FV18001. These were tested in the Korean War, 1950-53 along side its American WW2 equivalent and was judged much superior on every count. This led to more orders and the FV18001 adopted as the standard 4x4 1/4ton Utility from 1954. The truck used in Korea was powered by a 1.6 Liter Rover engine which gave a top speed of over 120km/h on road. The body could be adapted by simply removing parts of the bodywork such as the windshield and doors which were designed to be removable as desired. It was used as a utility, field car, radio car and weapons carrier. It features a towing hitch for a 1/4ton trailer. Its tough, rugged performance has made it a top selling Military Utility vehicle for over 70 years, adopted by many armies around the world.

Story by Philip Greenwood

Deutsch

Nach dem Zweiten Weltkrieg begann das britische Unternehmen Rover Car mit der Entwicklung eines landwirtschaftlichen Allradfahrzeugs, welches an Landwirte verkauft werden sollte, um Geld für die Entwicklung zukünftiger Limousinen zu erwirtschaften. Bis 1948 entstand ein 1/4 Tonnen schweres 4x4 Mehrzweckfahrzeug mit einer Karosserie aus kriegsbedingt überschüssigem Aluminium anstelle von Stahl. Das Fahrzeug verfügte über einen einfachen Hebel, um je nach den Straßenverhältnissen von 4x2- auf 4x4-Antrieb umzuschalten. Die Verwendung vieler handelsüblicher Teile senkte den Stückpreis auf fast die Hälfte des Preises seiner Konkurrenten.

Obwohl die britische Armee bereits mehrere ähnliche Fahrzeuge in der Entwicklung hatte, wurde 1949 eine Kleinserie des Rover Utility bestellt, die später die Bezeichnung FV18001 erhielt. Diese Fahrzeuge wurden im Koreakrieg 1950-53 zusammen mit seinem amerikanischen Pendant aus dem Zweiten Weltkrieg getestet und in jeder Hinsicht für überlegen befunden.

Dies führte zu weiteren Aufträgen, und der FV18001 wurde ab 1954 als Standard 4x4 1/4t Fahrzeug eingesetzt. Der in Korea eingesetzte Rover wurde von einem 1,6-Liter Rover Motor angetrieben, der eine Höchstgeschwindigkeit von über 120km/h auf der Straße. Die Karosserie konnte durch einfaches Entfernen von Teilen der Karosserie wie Windschutzscheibe und Türen angepasst werden. Er wurde als Transportfahrzeug, Funkwagen und Waffenträger eingesetzt. Er verfügt über eine Anhängerkupplung für einen 1/4-Tonnen-Anhänger. Seine robuste und widerstandsfähige Leistung hat ihn seit über 70 Jahren zu einem der meistverkauften militärischen Nutzfahrzeuge gemacht, das von vielen Armeen auf der ganzen Welt eingesetzt wurde und wird.

Translation by Sven Schroeder

日文

英国陸軍 FV18001 4x4 1/4 トン ユーティリティ
第二次世界大戦後、英国のローバー・カー社は将来のサルーンカー開発資金を集めるために農家に販売する四輪駆動農業用車両の開発に着手した。1948年までに、鋼鉄ではなく戦時余剰のアルミニウムで車体を製作した1/4トンの4x4多目的車が開発されました。道路状況に応じて4x2ドライブから4x4ドライブに切り替えるためのシンプルな「ドッグクラッチ」を備えていました。市販部品を多用することで単価も競合他社の半額近くに抑えました。英国軍はすでに開発中の同様の車両をいくつか所有していましたが、1949年に少量のローバーユーティリティカーが発注され、後にFV18001と呼ばれるようになりました。その車両は朝鮮戦争(1950~1953年)で第二次世界大戦時のアメリカ製同等品と並行してテストされ、あらゆる点ではるかに優れていると判断されました。これにより注文が増加し、FV18001は1954年から標準の4x4 1/4トンユーティリティとして採用されました。韓国で使用されているトラックは、1.6リッターのローバーエンジンを搭載しており、道路での最高速度は120km/h以上でした。必要に応じて取り外し可能に設計されているフロントガラスやドアなどの車体部品を取り外すだけで、車体を適合させることができます。実用フィールドカー、ラジオカー、武器運搬車として使用されました。1/4トンのトレーラー用の牽引ヒッチも備えています。そのタフで頑丈な性能により、70年以上にわたり、世界中の多くの軍隊で採用され、最も売れている軍用実用車となっています。



繁體中文 韓戰英軍FV18001 Mk. 1 80吋軸距1/4噸4x4多用途車輛與10-cwt班讓拖車

二戰後英國的路華汽車公司開始研發一款4x4農夫車，出售給農民，為未來的房車籌集開發資金。到1948年，一輛1/4噸的4x4多用途車出現了，車身由戰爭剩餘的鋁而非鋼製成。它有一個簡單的狗頭狀的離合器，可以根據路況從4x2切換到4x4功能。它使用了許多商業部件，也將單價降至競爭對手的近一半。儘管英國軍隊已經有幾種類似的汽車在開發中，但1949年仍訂購了一小批這種路華多用途車，後來被命名為FV18001。這些產品在1950-53年的韓戰中與美國二戰中的同類產品一起進行了測試，在各個方面都被認為是優越的。這導致接收了更多的訂單，FV18001從1954年起被用作標準的4x4 1/4噸多用途車輛使用。這種在韓戰使用過的輕型車輛由1.6升的羅孚發動機提供動力，在公路上的最高速度超過120公里/小時。可以通過簡單拆卸車身的部件來進行調整，例如擋風玻璃和車門，這些部件被設計成可以根據需要拆卸。用作多用途車、野戰車、無線電車和武器運輸車。它具有適用於1/4噸拖車的牽引掛接裝置。70多年來，其堅固耐用的性能使其成為最暢銷的軍用多用途車，被世界各地的許多軍隊所採用。

簡體中文 朝鮮戰爭英軍FV18001 Mk. 1 80吋軸距1/4噸4x4多用途車輛與10-cwt班讓拖車

戰後英國的羅孚汽車公司開始研發一款4x4農用車，出售給農民，為未來的房車籌集開發資金。到1948年，一輛1/4噸的4x4多用途車出現了，車身由戰爭剩餘的鋁而非鋼製成。它有一個簡單的狗頭狀的離合器，可以根據路況從4x2切換到4x4功能。它使用了許多商業部件，也將單價降至競爭對手的近一半。儘管英國軍隊已經有幾種類似的汽車在開發中，但1949年仍訂購了一小批這種羅孚多用途車，後來被命名為FV18001。這些產品在1950-53年的朝鮮戰爭中與美國二戰中的同類產品一起進行了測試，在各個方面都被認為是優越的。這導致接收了更多的訂單，FV18001從1954年起被用作標準的4x4 1/4噸多用途車輛使用。這種在朝鮮戰爭中使用過的輕型車輛由1.6升的羅孚發動機提供動力，在公路上的最高速度超過120公里/小時。可以通過簡單拆卸車身的部件來進行調整，例如擋風玻璃和車門，這些部件被設計成可以根據需要拆卸。用作多用途車、野戰車、無線電車和武器運輸車。它具有適用於1/4噸拖車的牽引掛接裝置。70多年來，其堅固耐用的性能使其成為最暢銷的軍用多用途車，被世界各地的許多軍隊所採用。

Sprue Parts List

A x 1

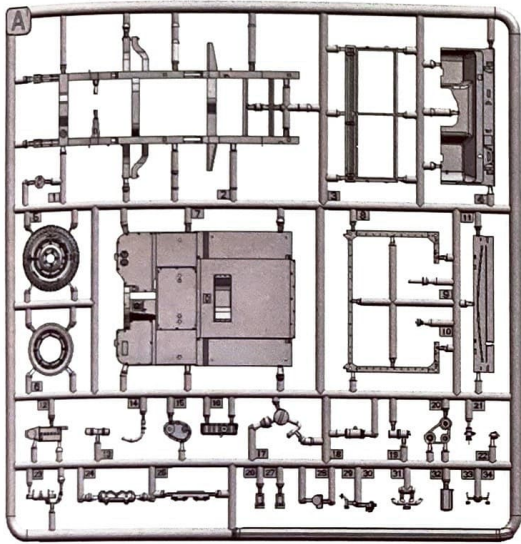

Ab x 1

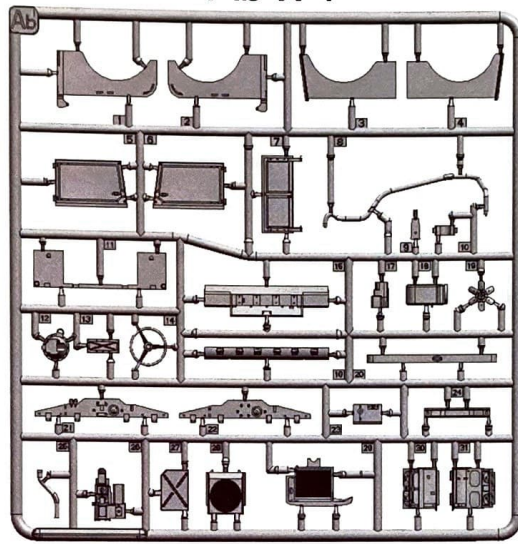

B x 1

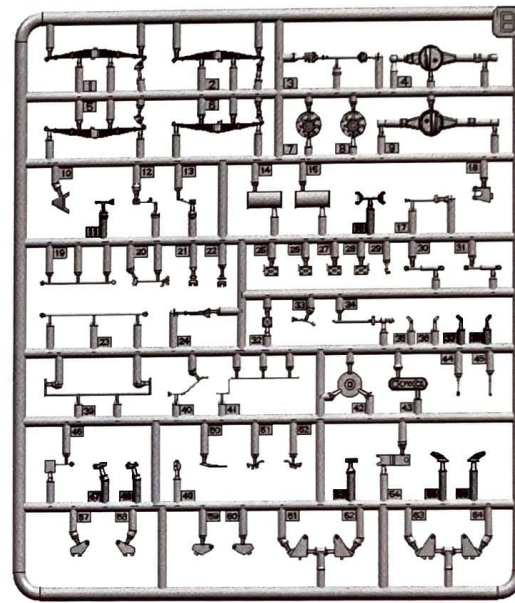

T x 1

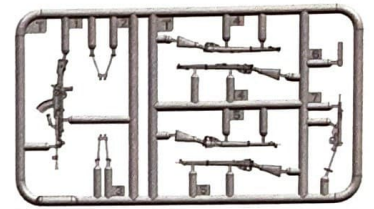

D x 2

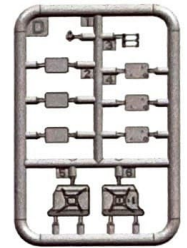

Bc x 1

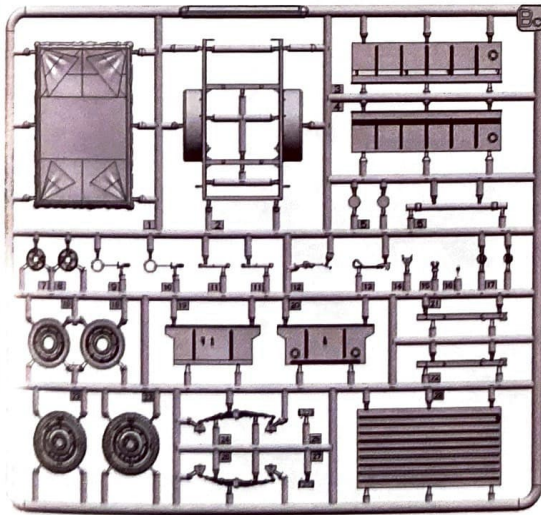

C x 1



Cb x 1

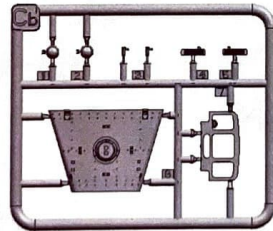

Ce x 1

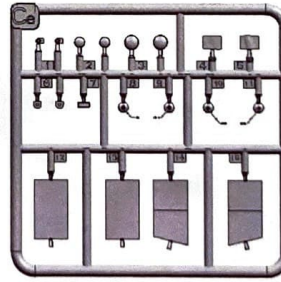

Cf x 4

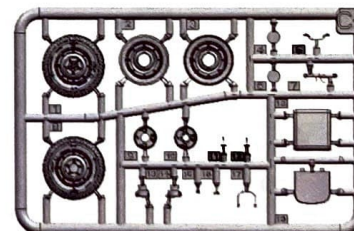

P x 1

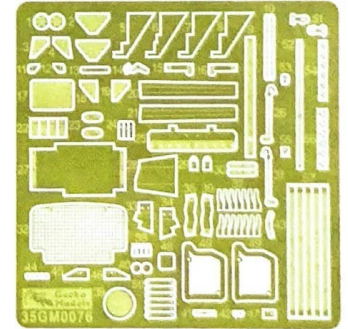

C x 1

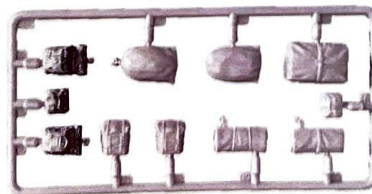

Hf x 1

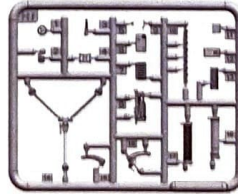

Decal x 1

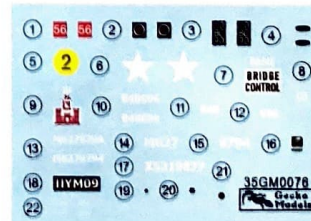

Wire x 1



Rope x 1



1

Cf14、 Cf13 and B4 not cement

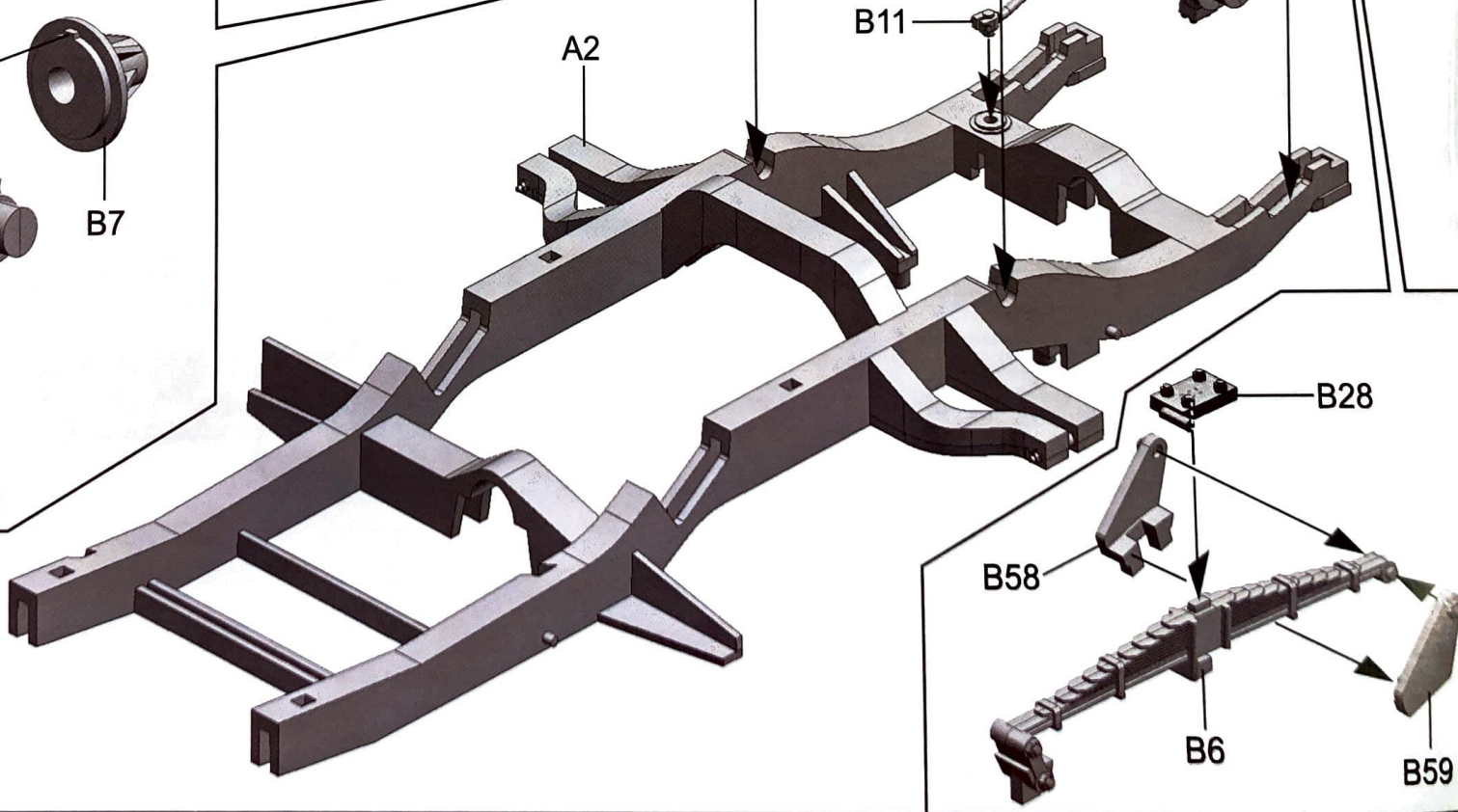
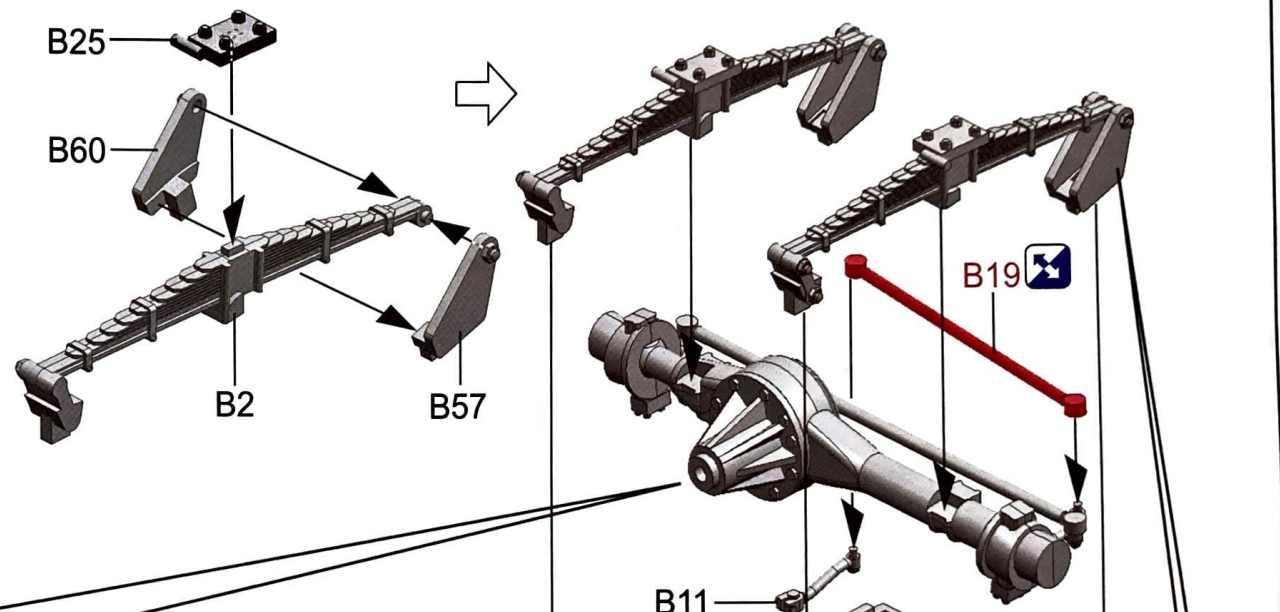
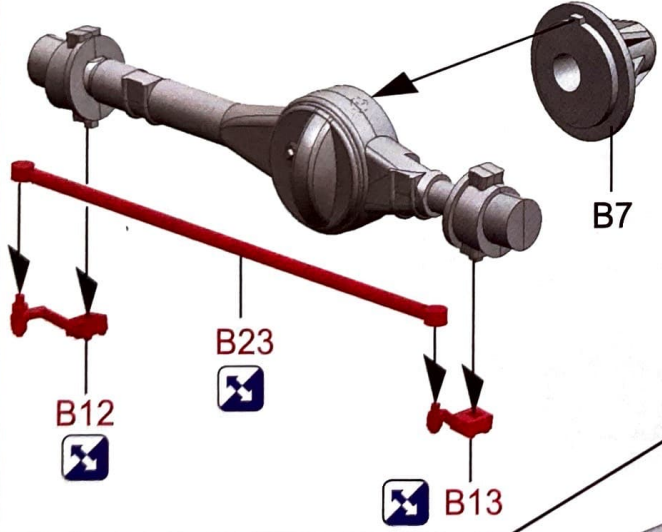
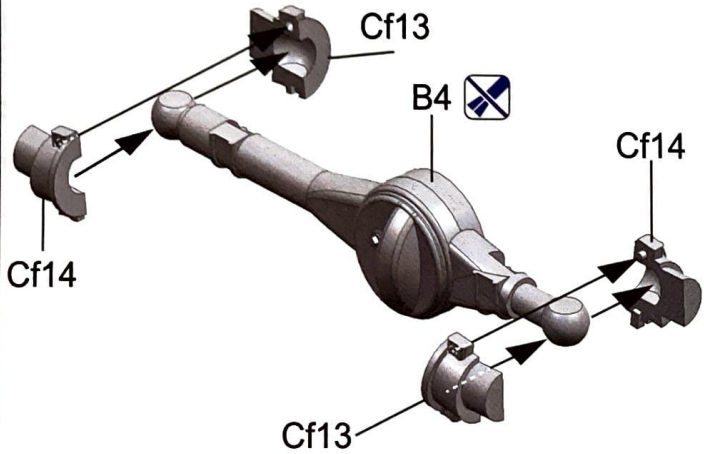

2

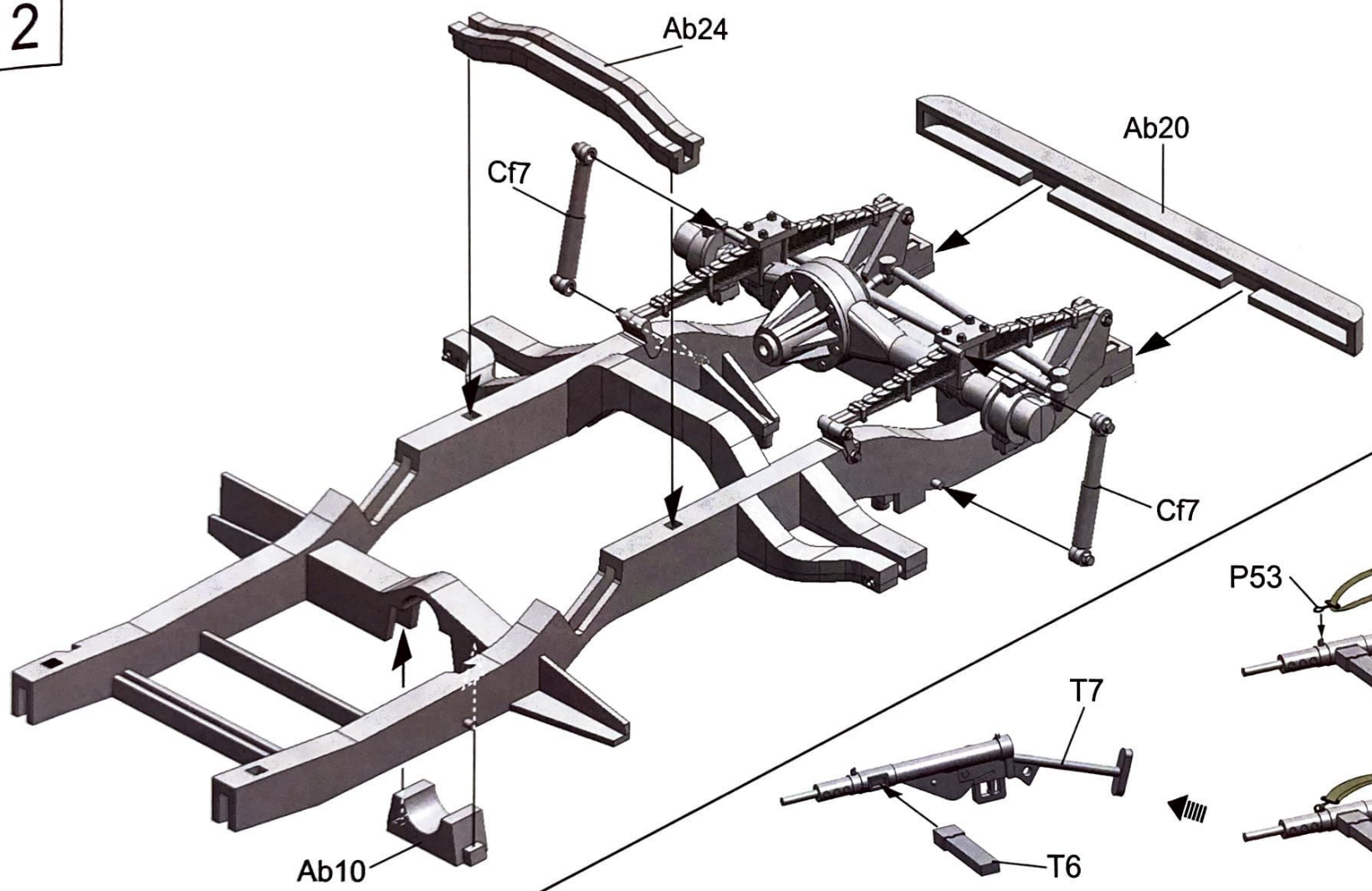

3

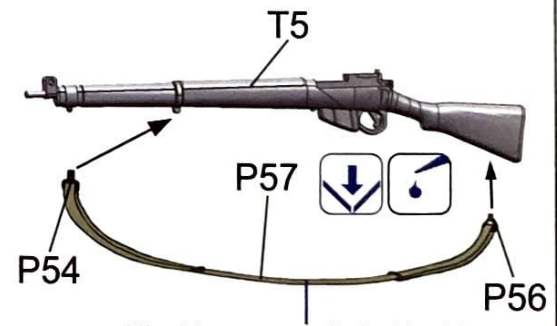
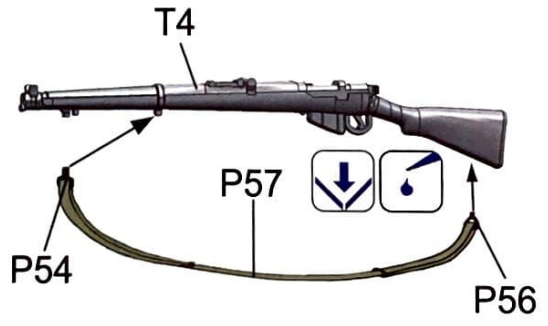
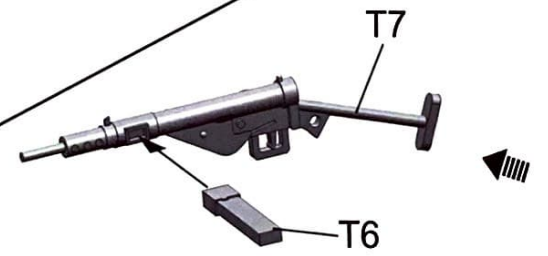
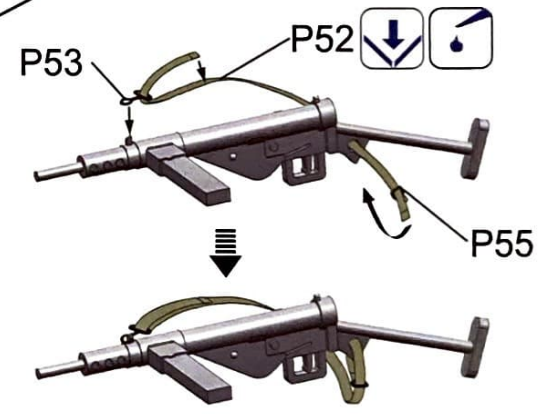

 Bend
Biegen

 Instant Glue For Metal
Sekundenkleber verwenden

Khaki green or light khaki

4

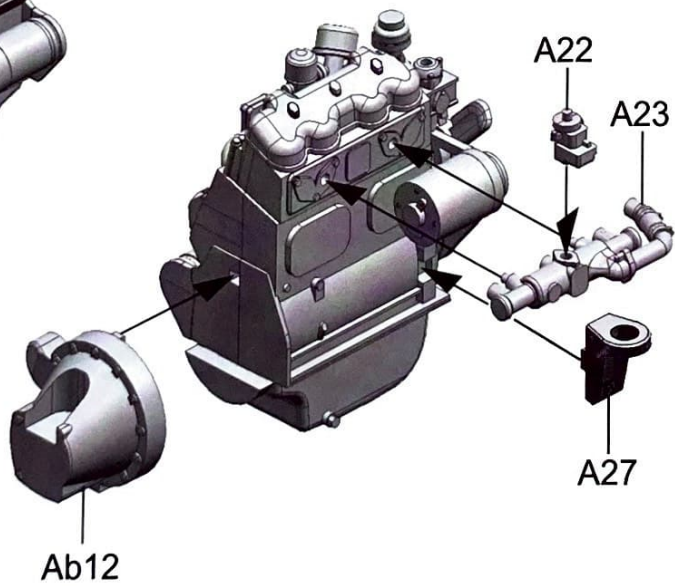
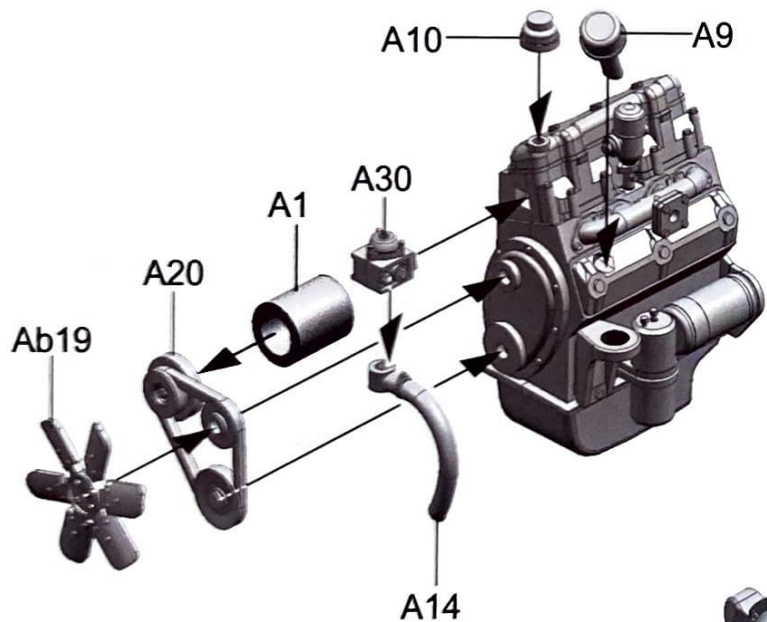
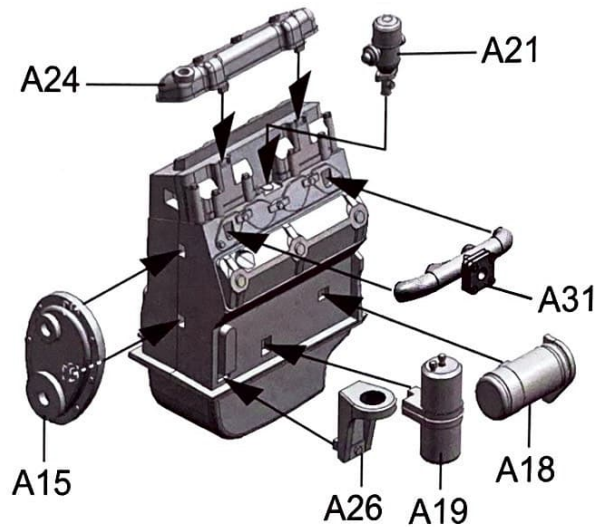
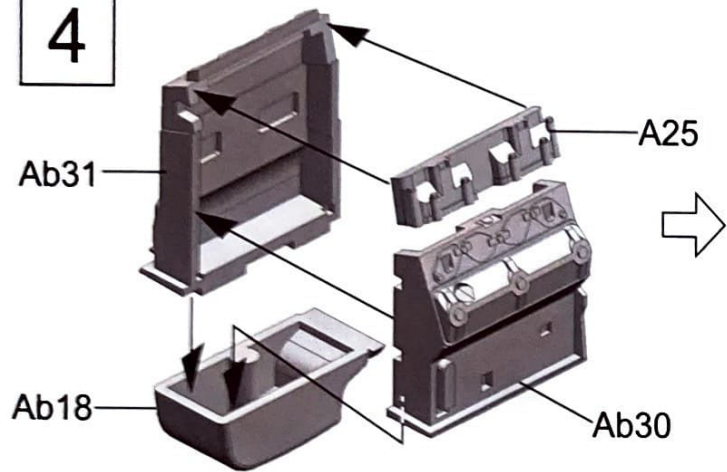

C

5

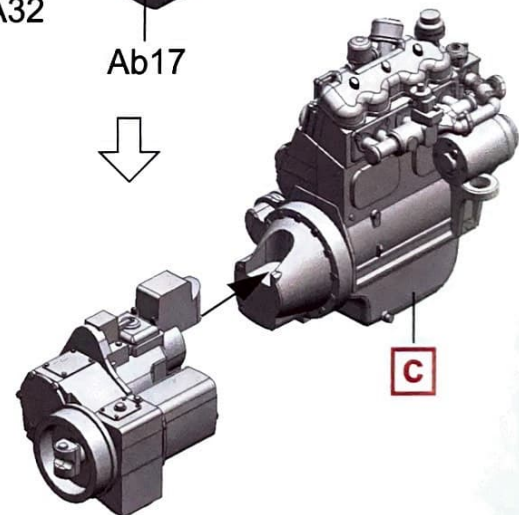
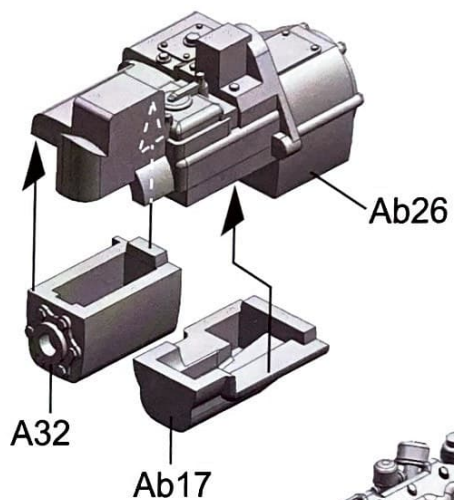
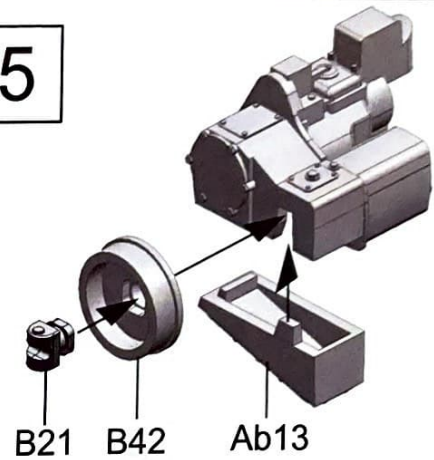

C

6

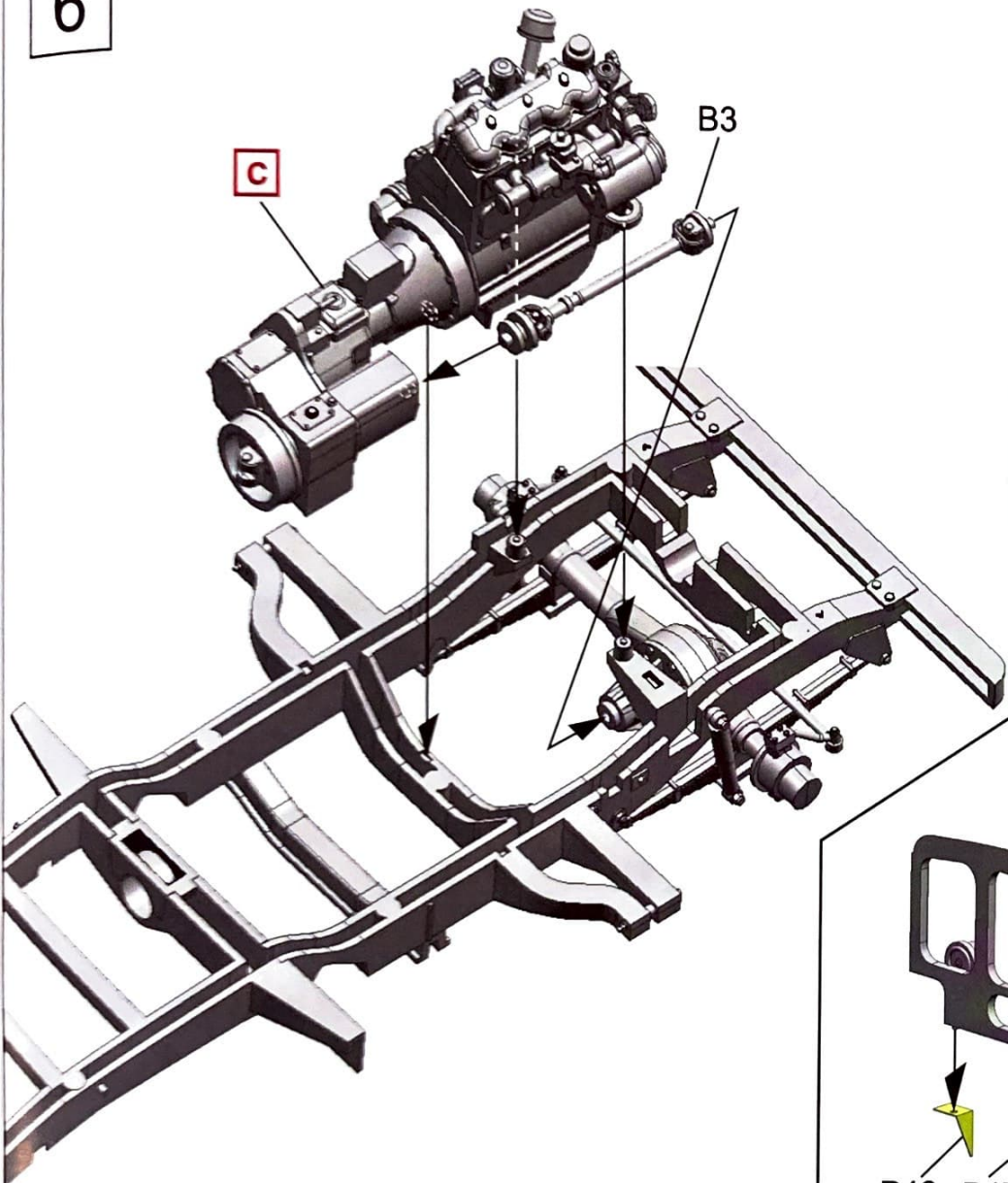

7

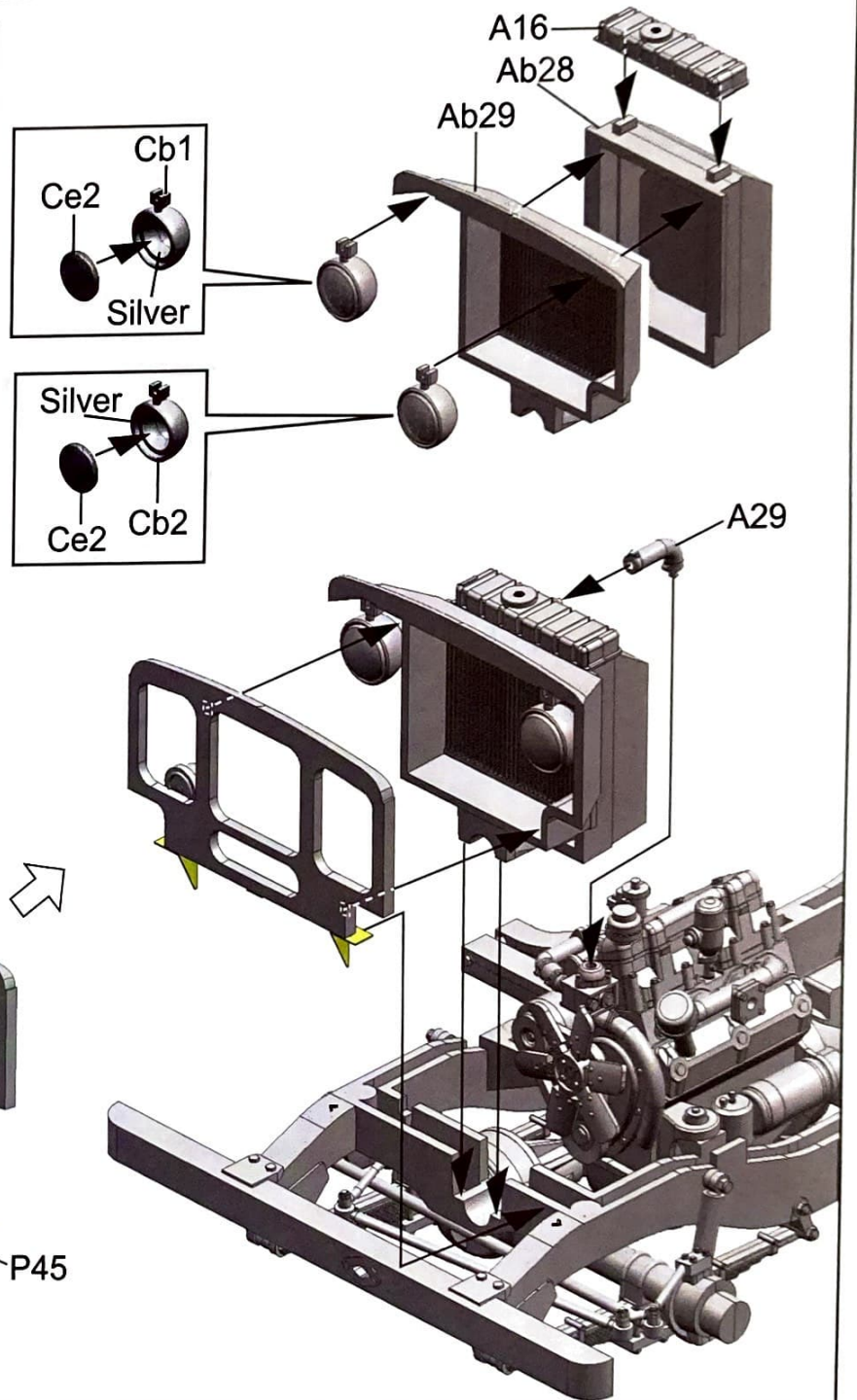

8

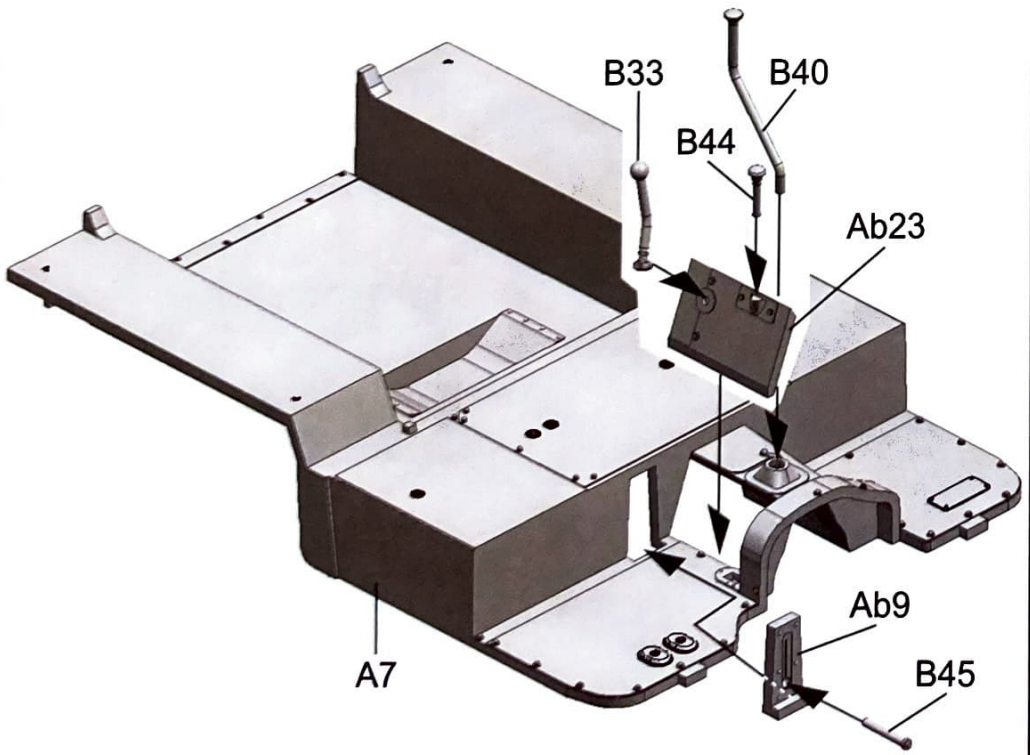
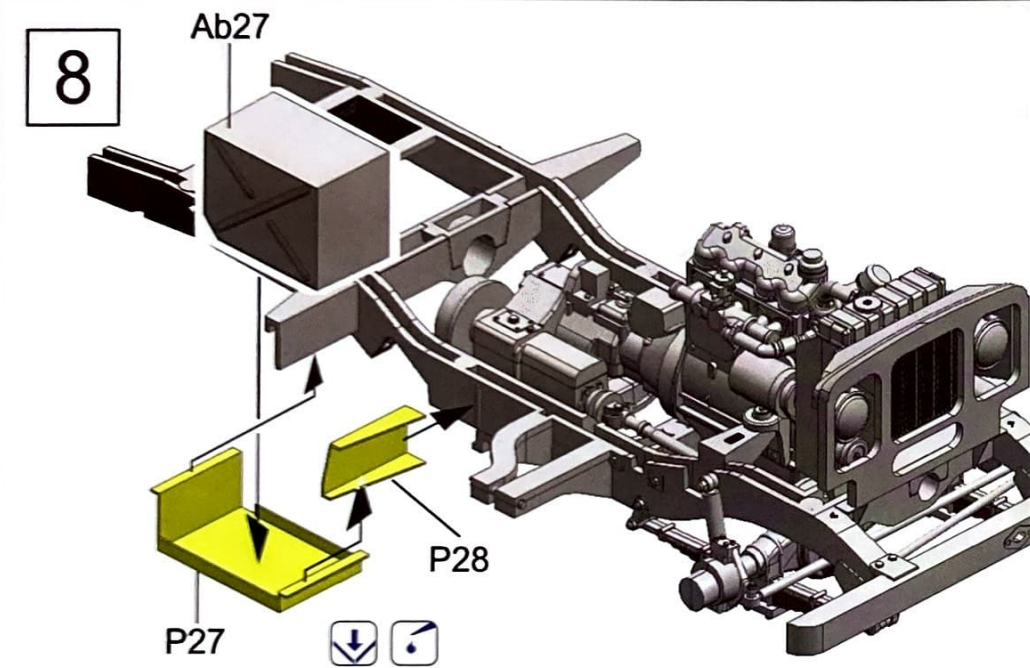

9

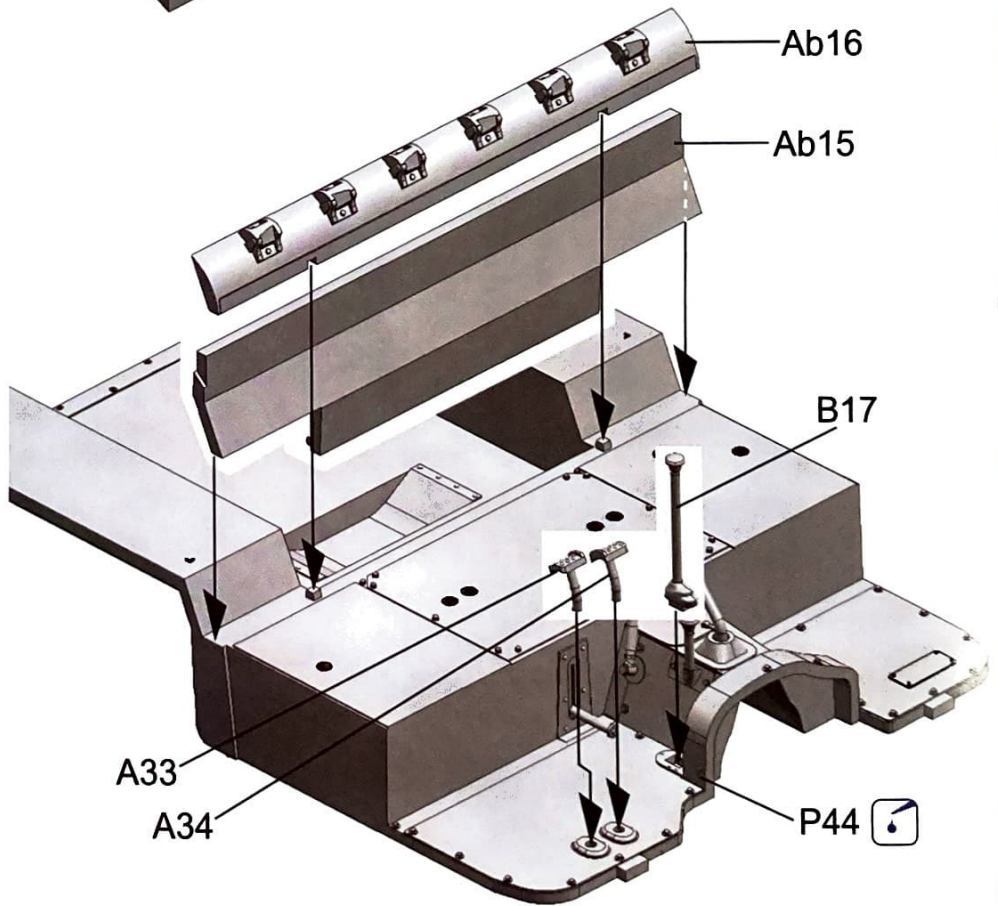
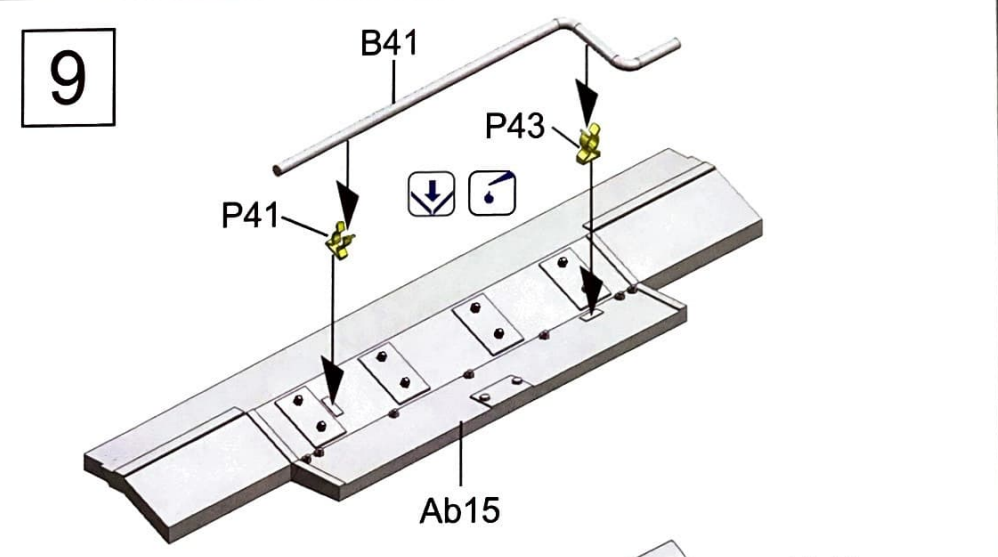

10

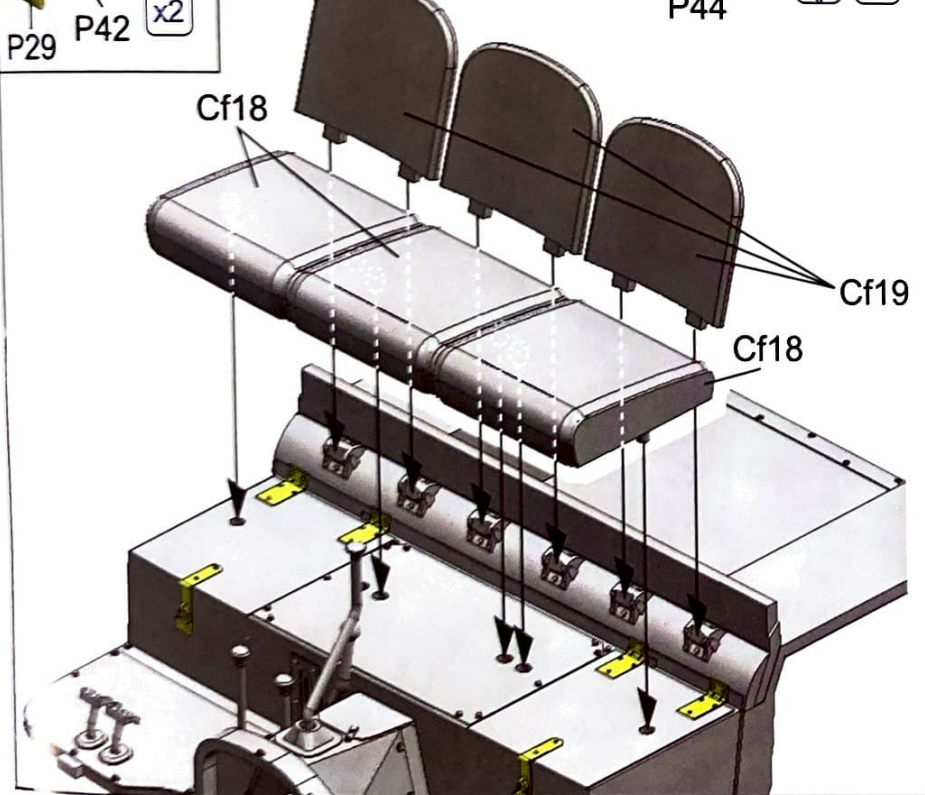
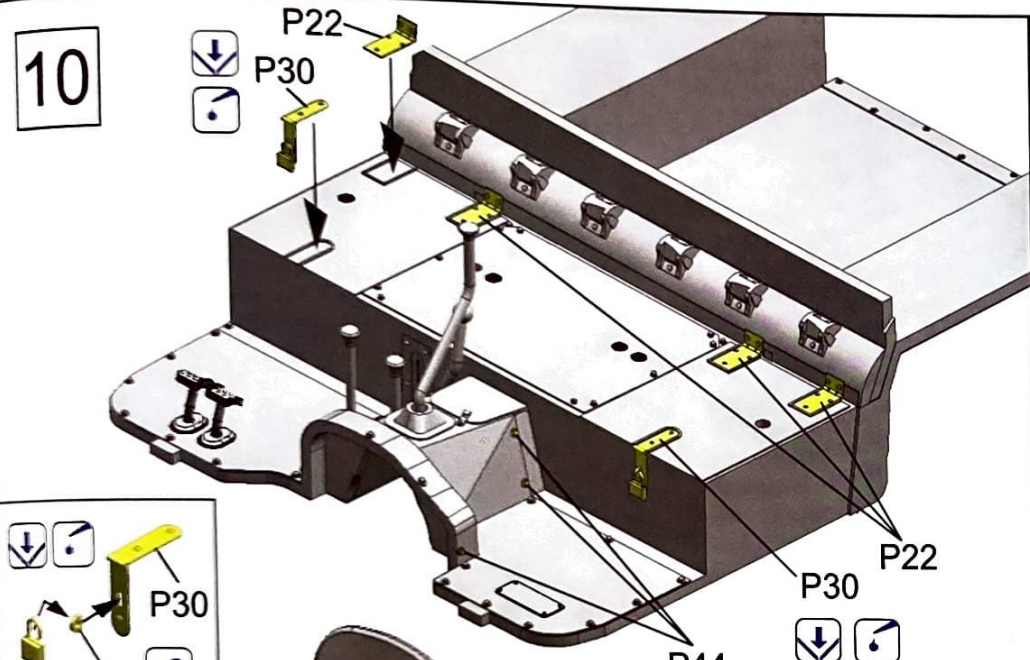

11

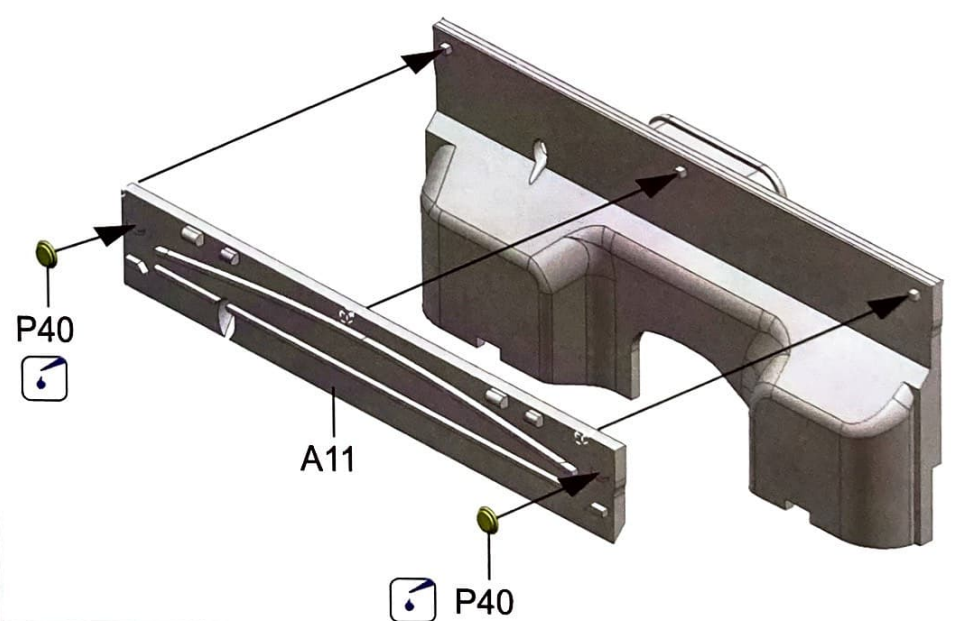
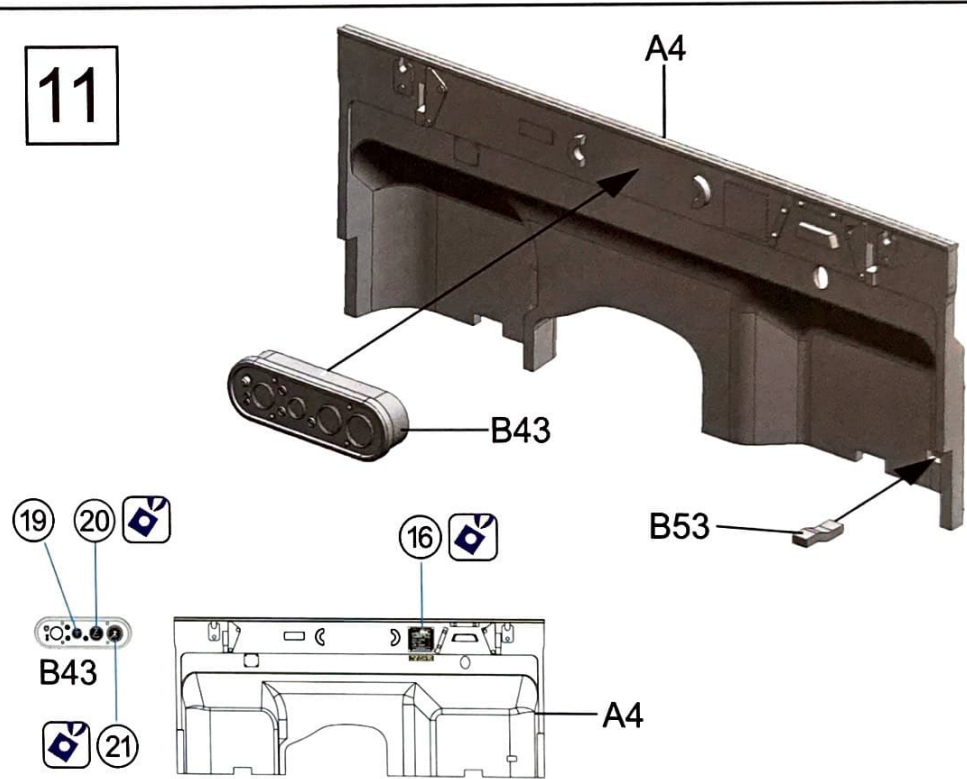

12

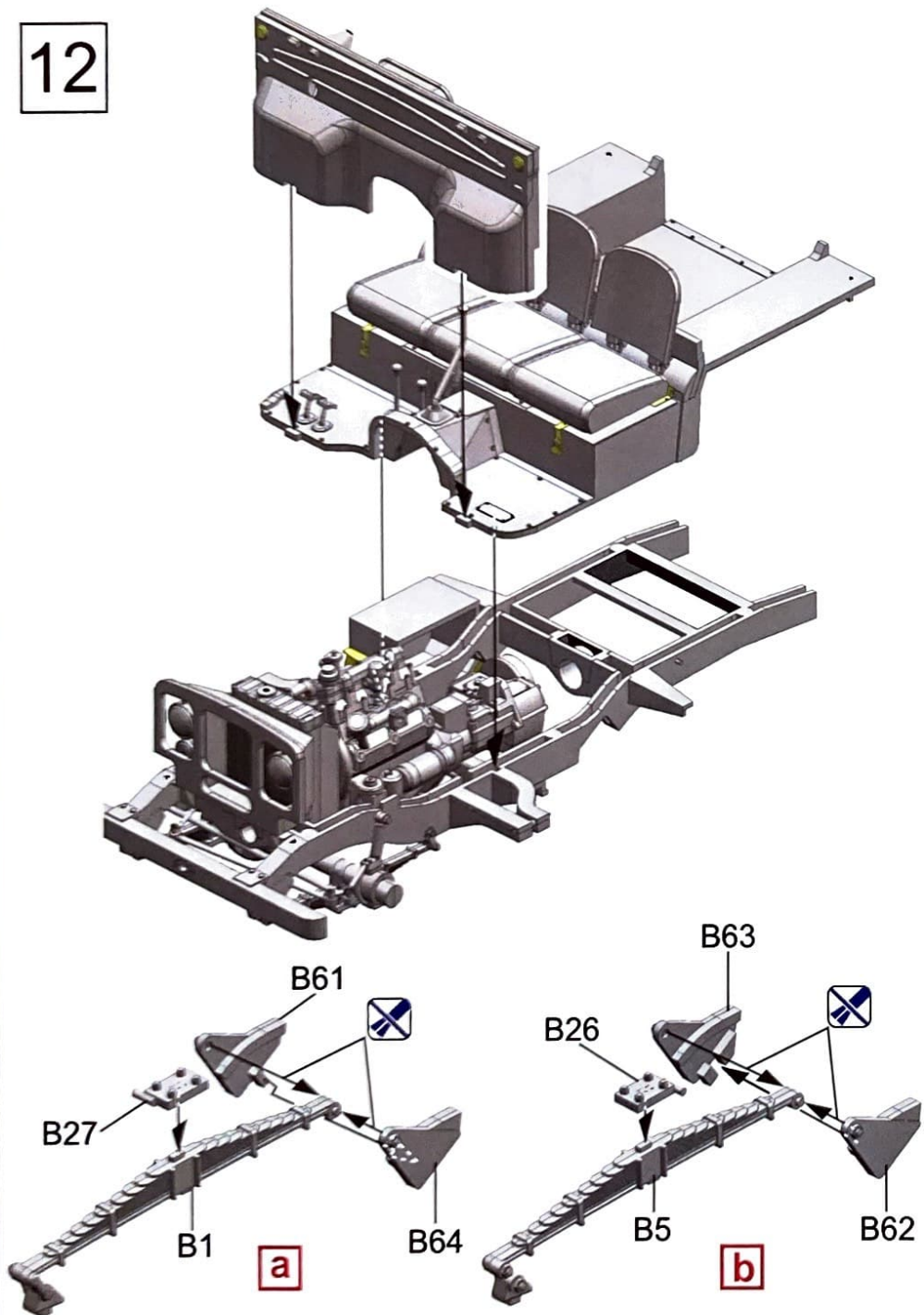

13

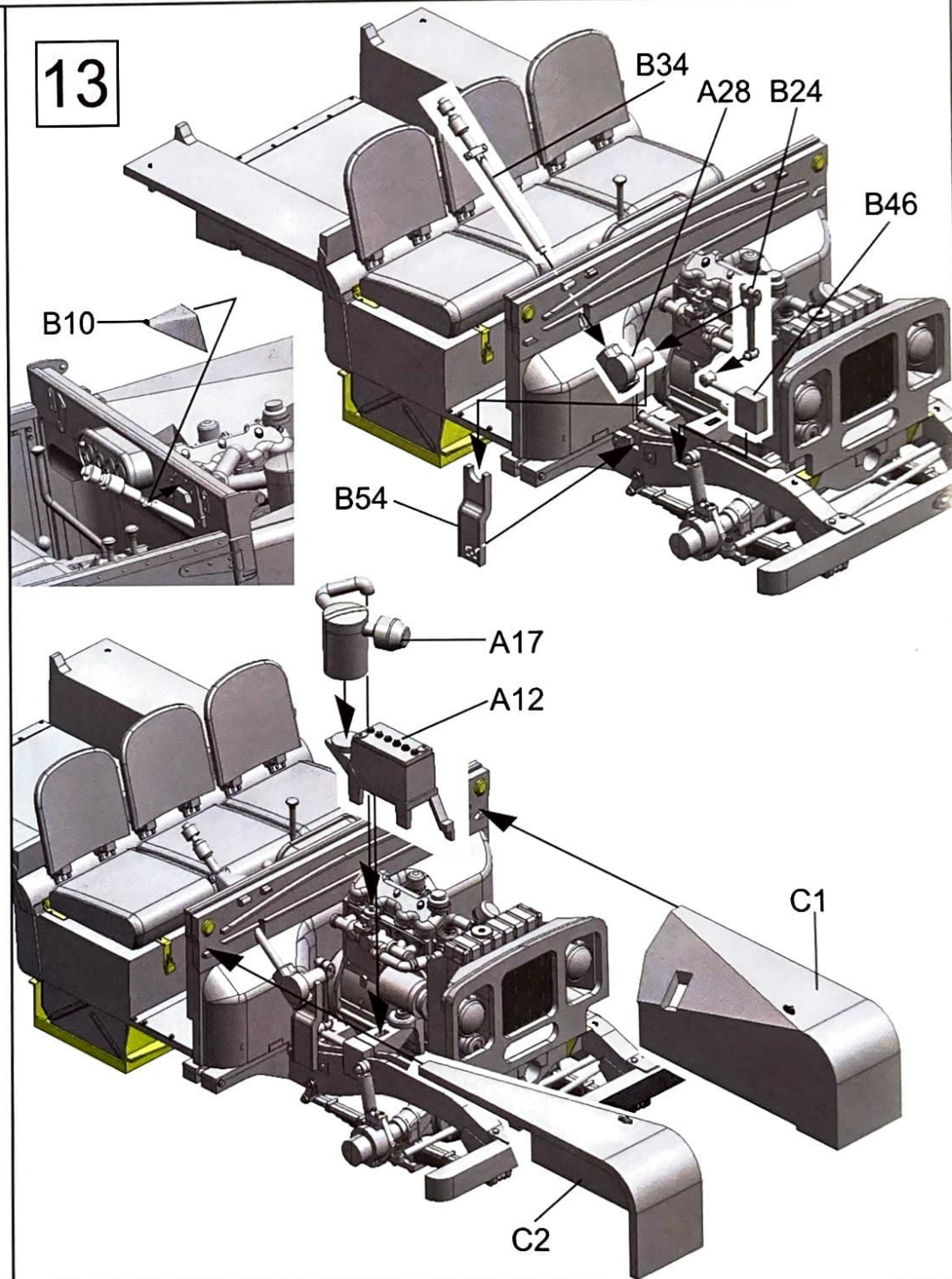

14

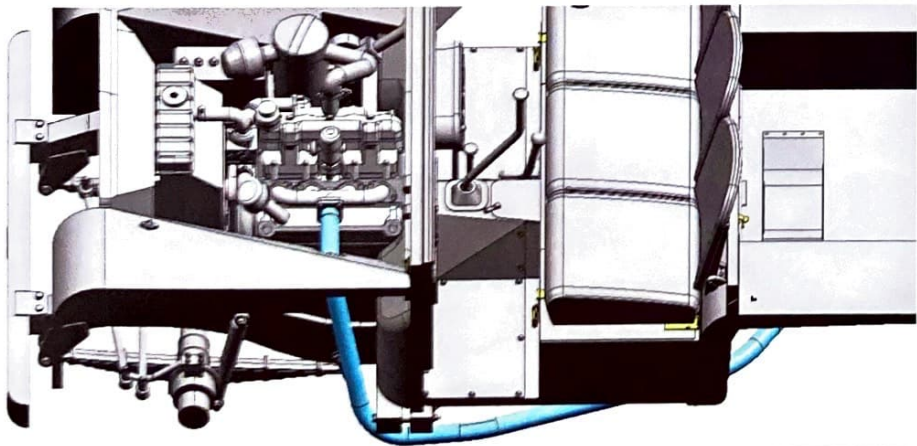
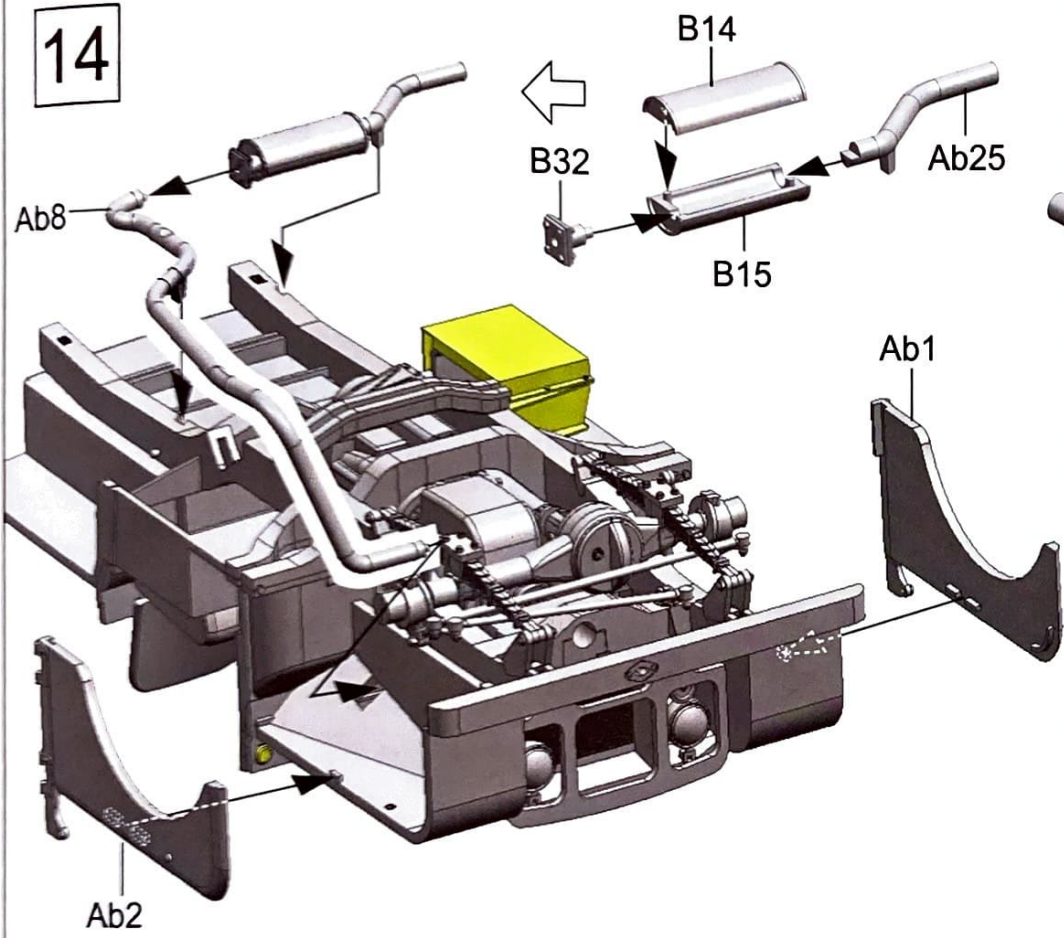

15

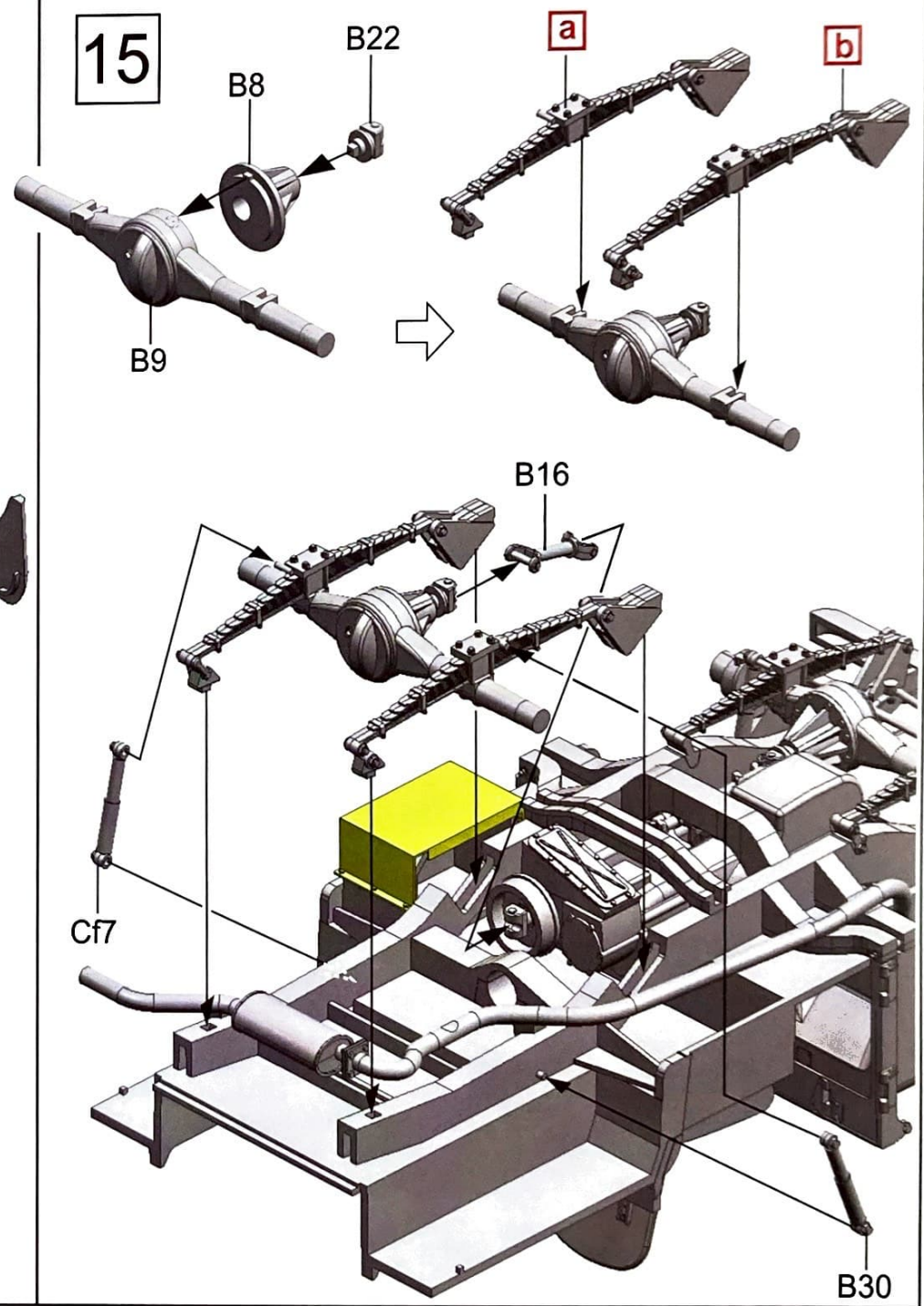

16

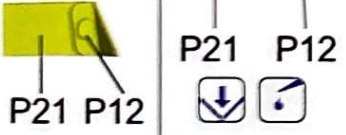
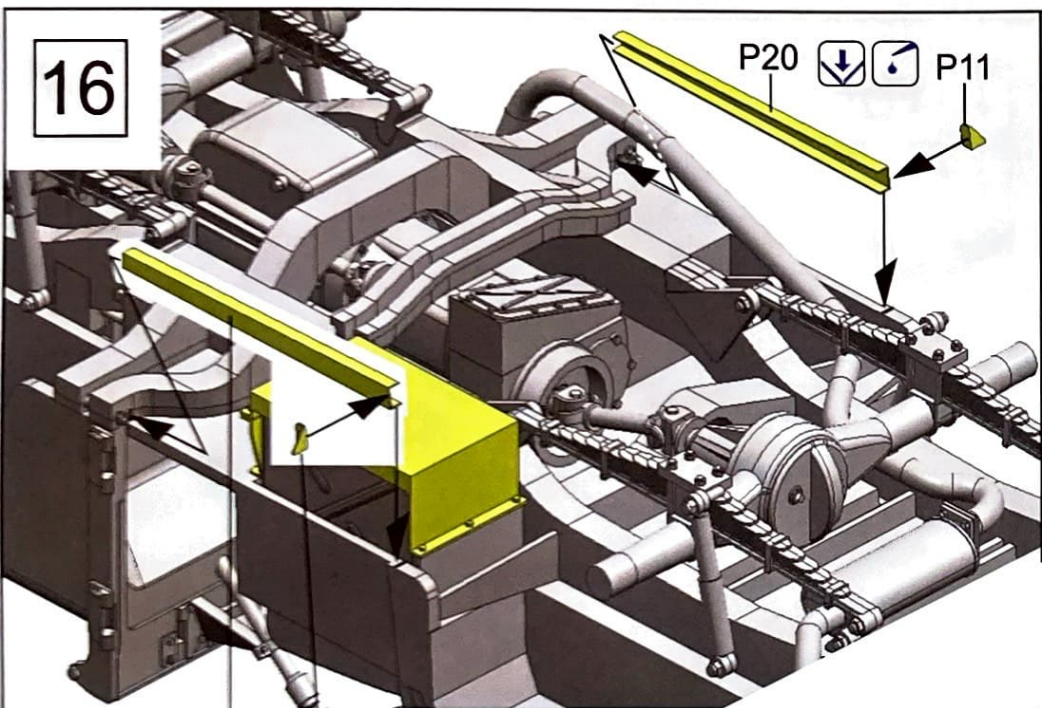

17

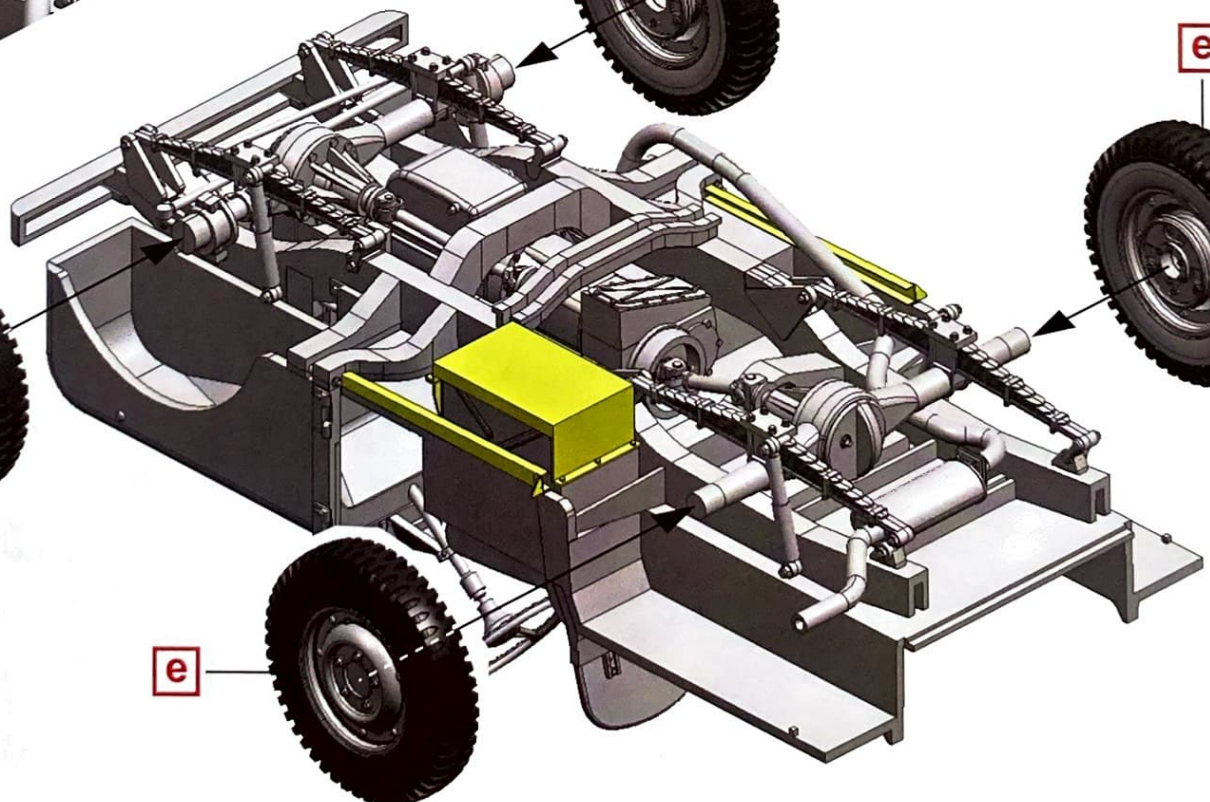
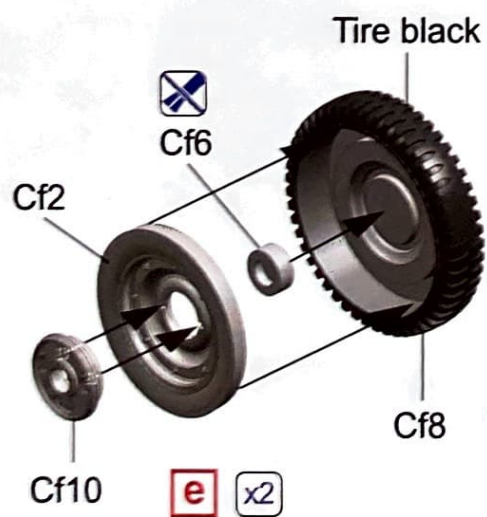
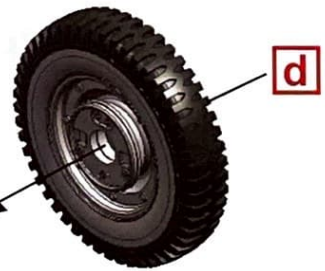
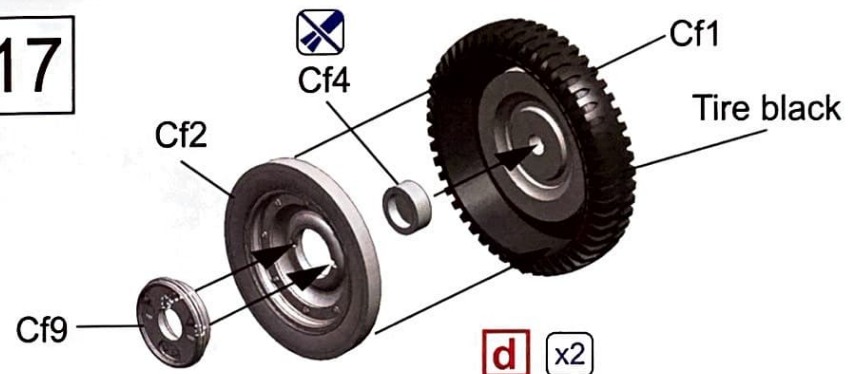

Wheels direction to right

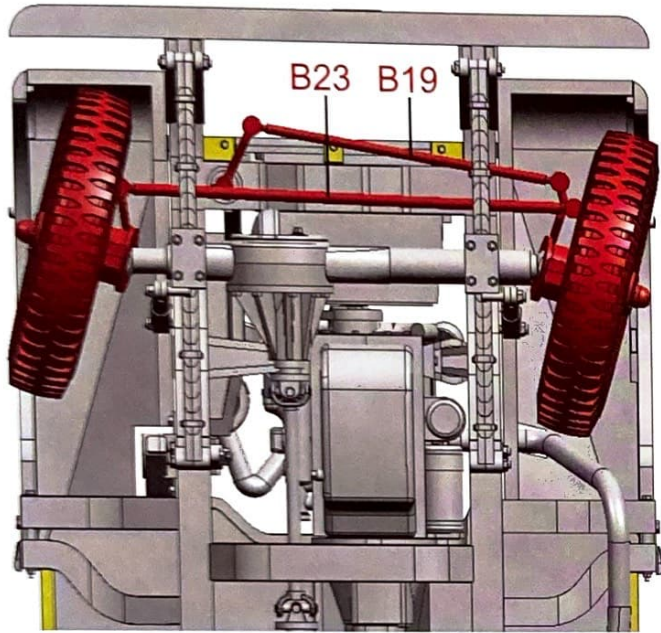

18

Wheels direction to left

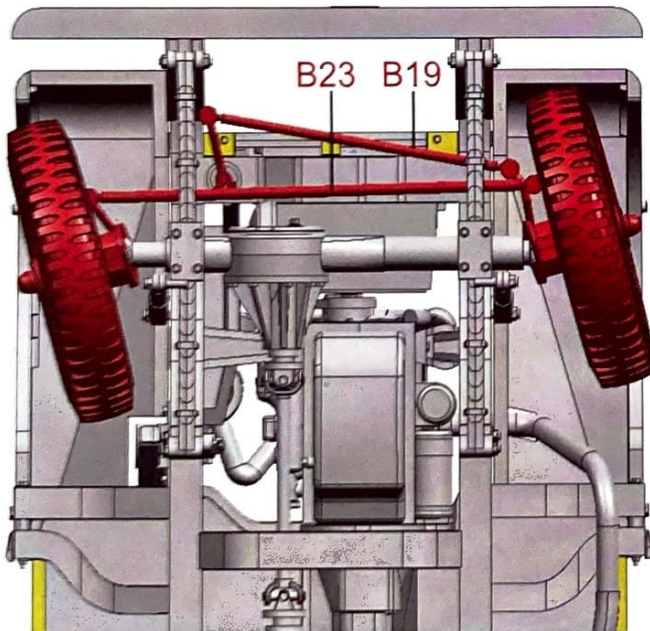

19

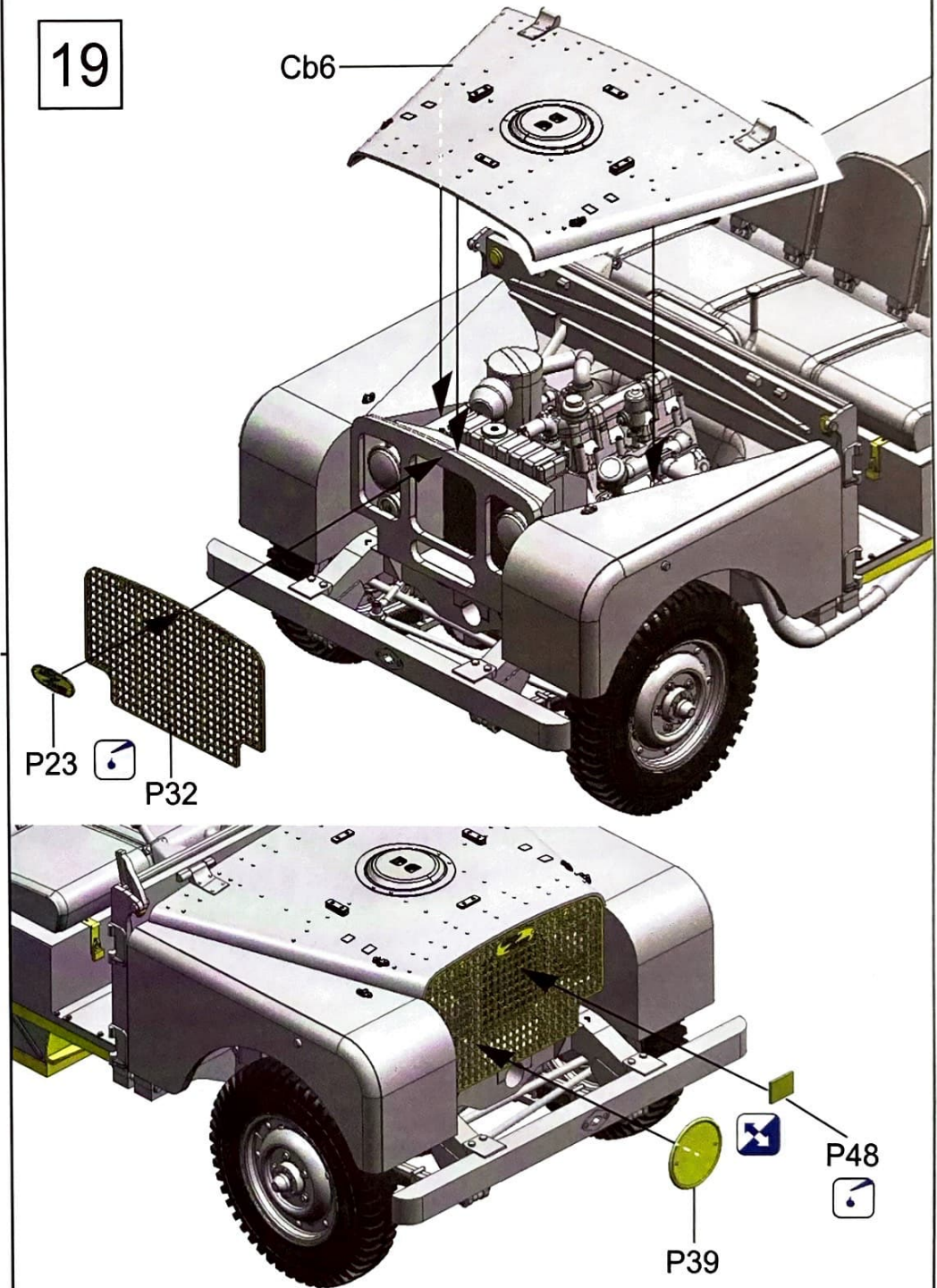

20

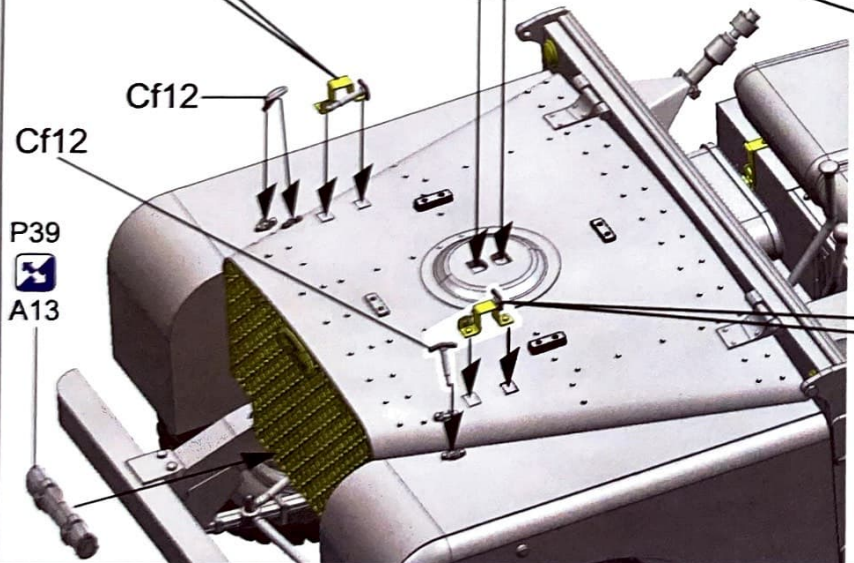
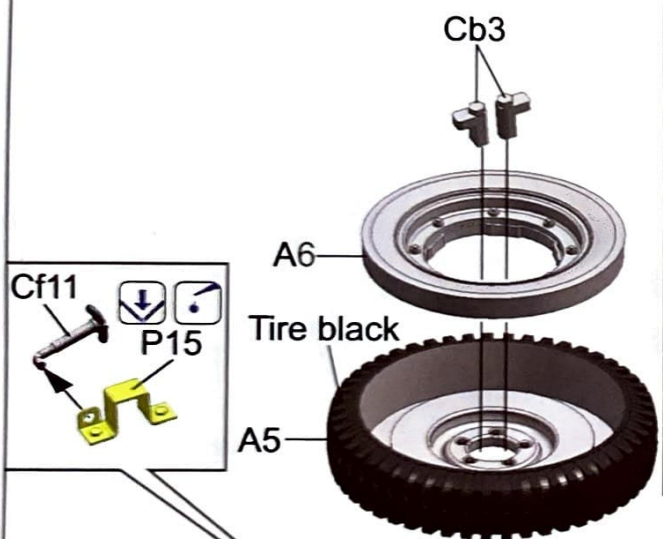

21

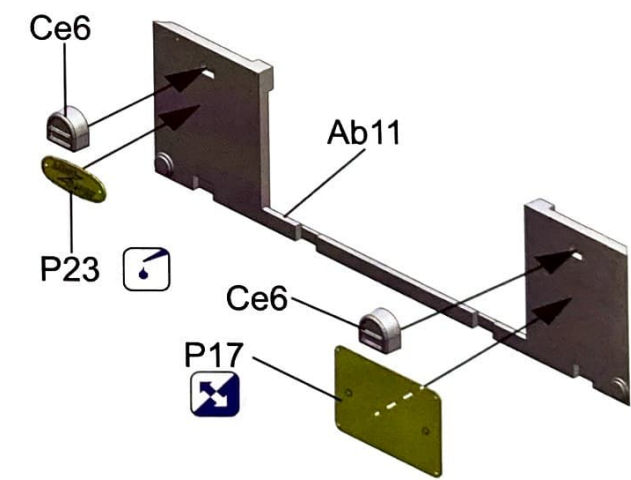
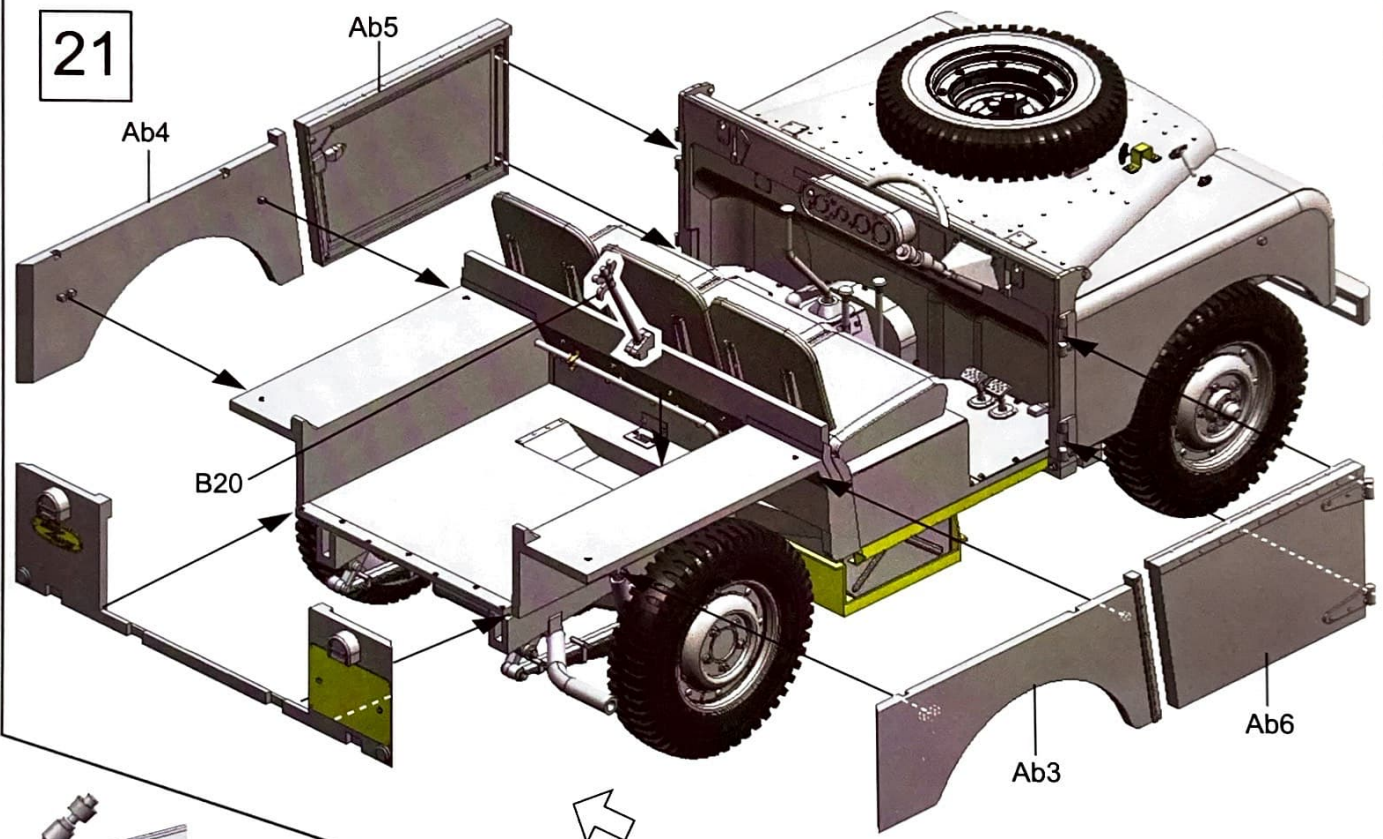

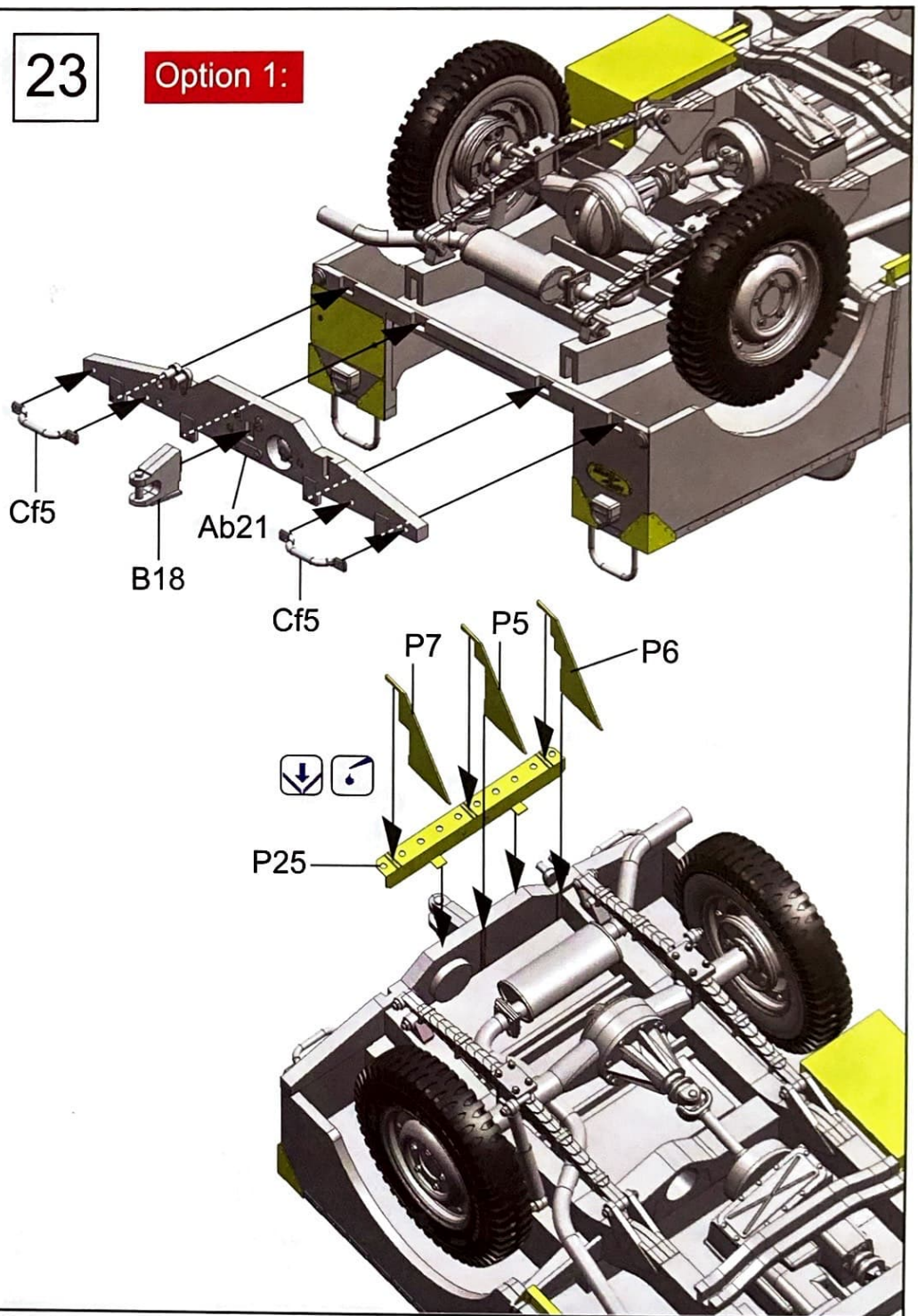
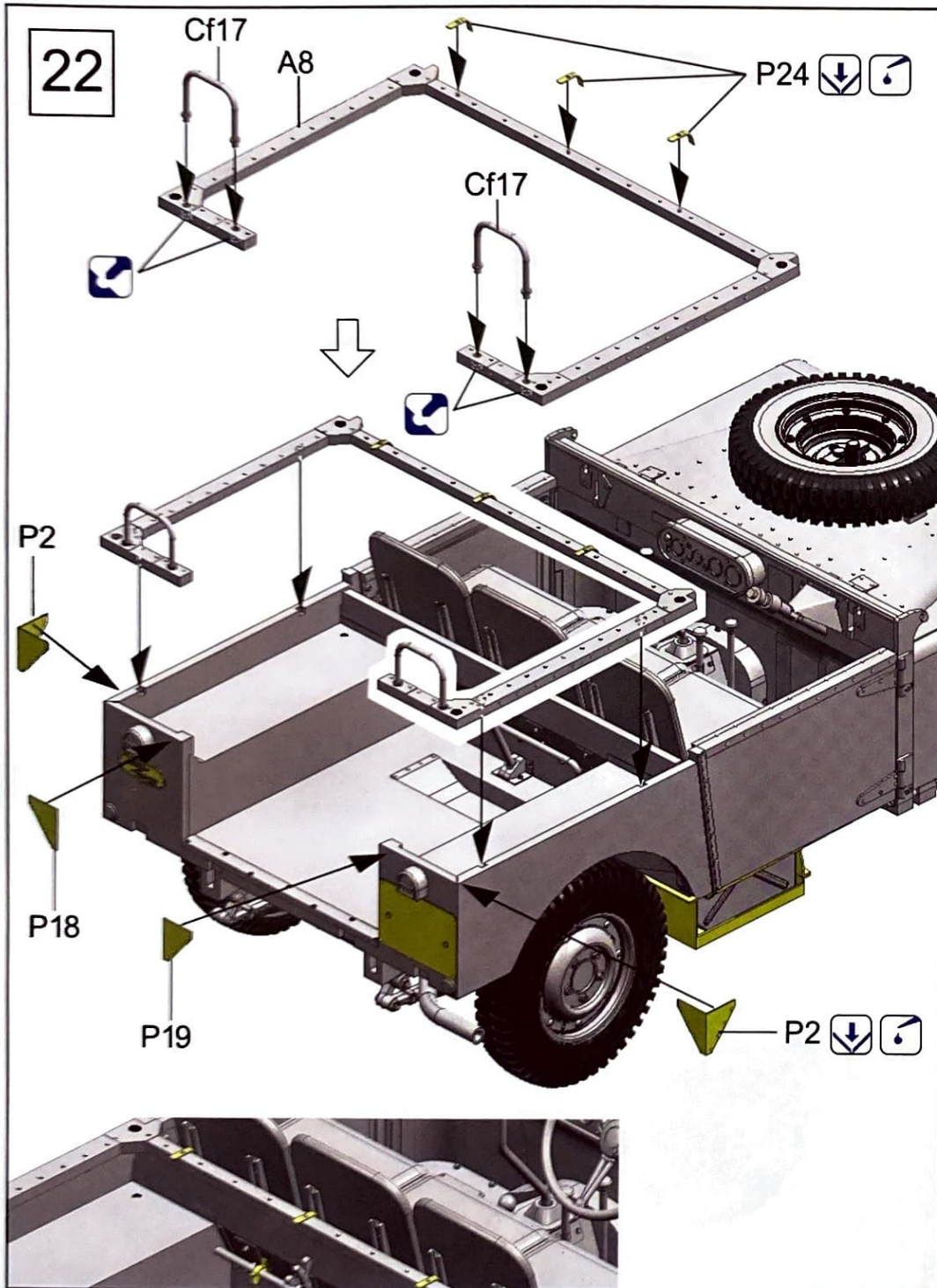

24

Option 2:

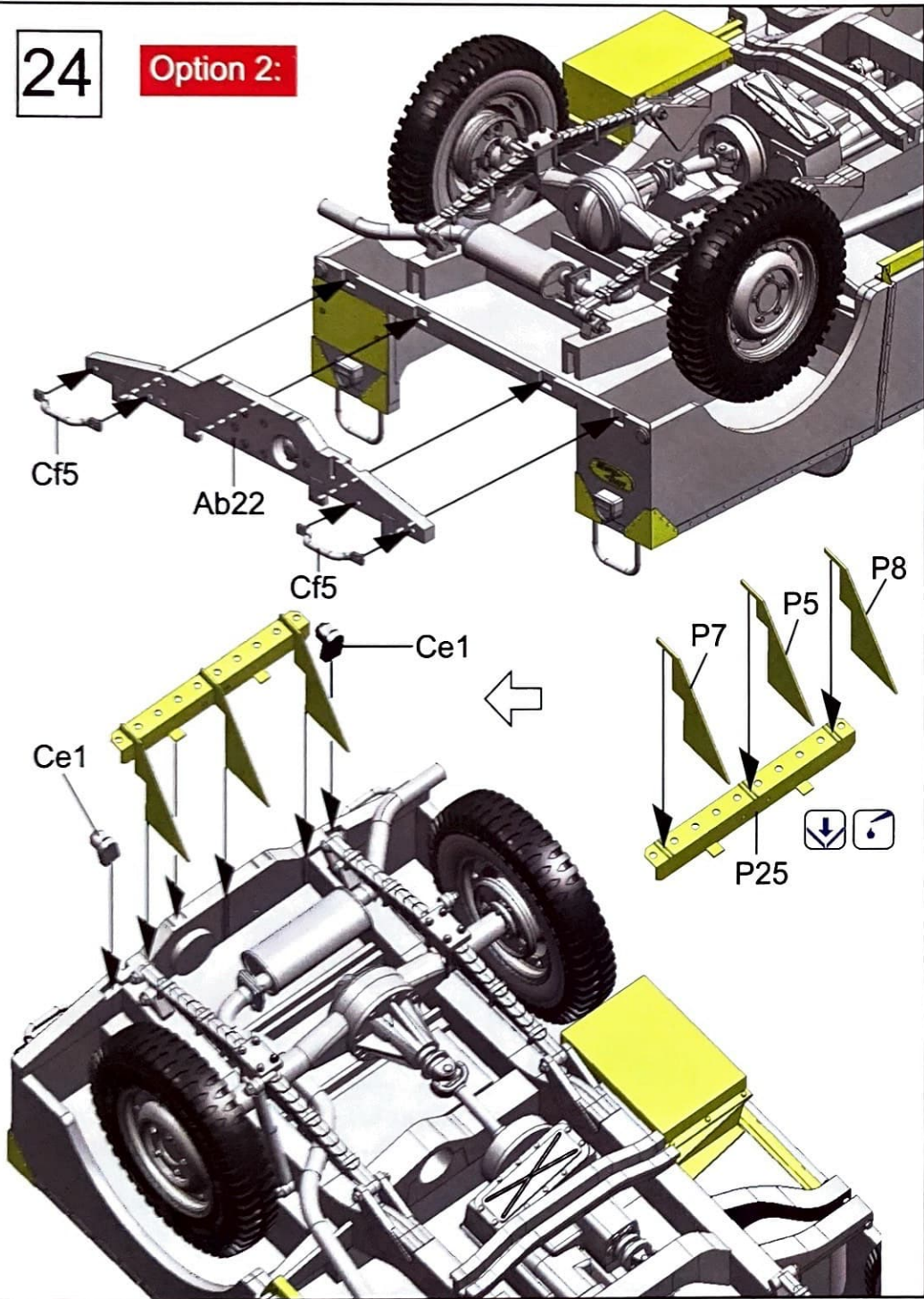

25

Closed position :

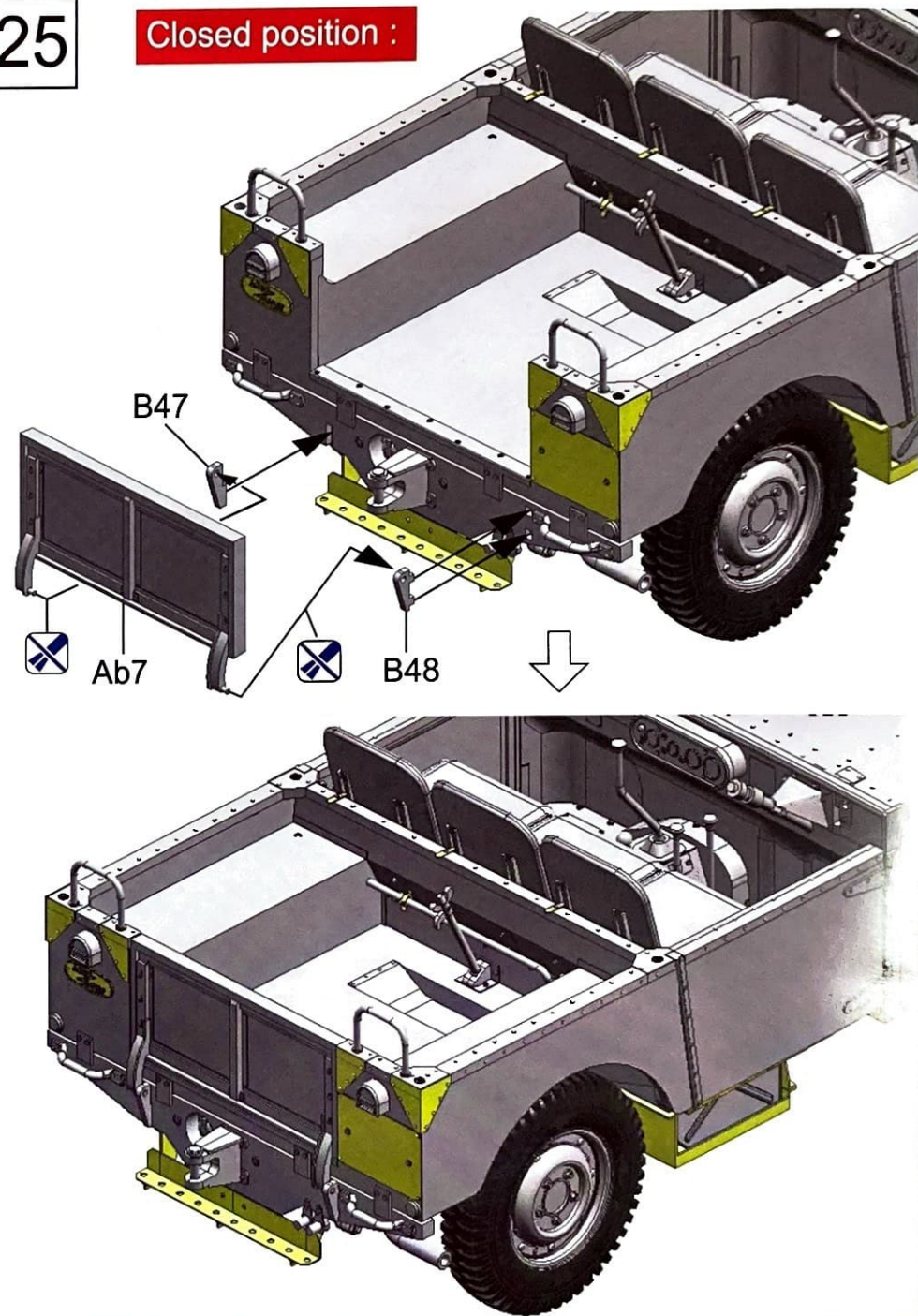

26

Open position :

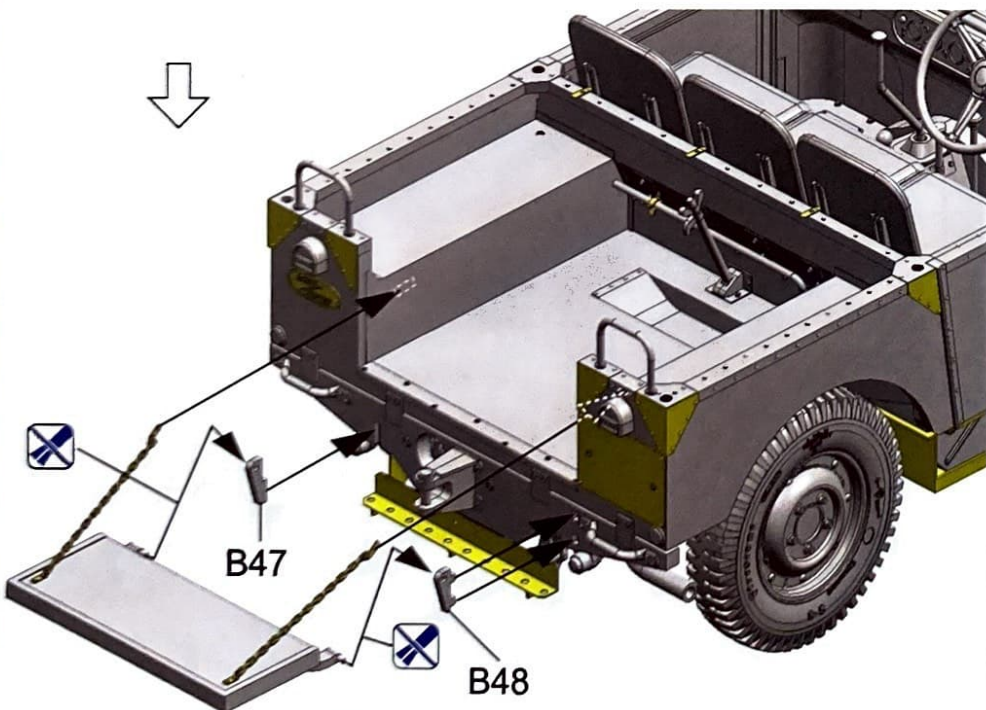
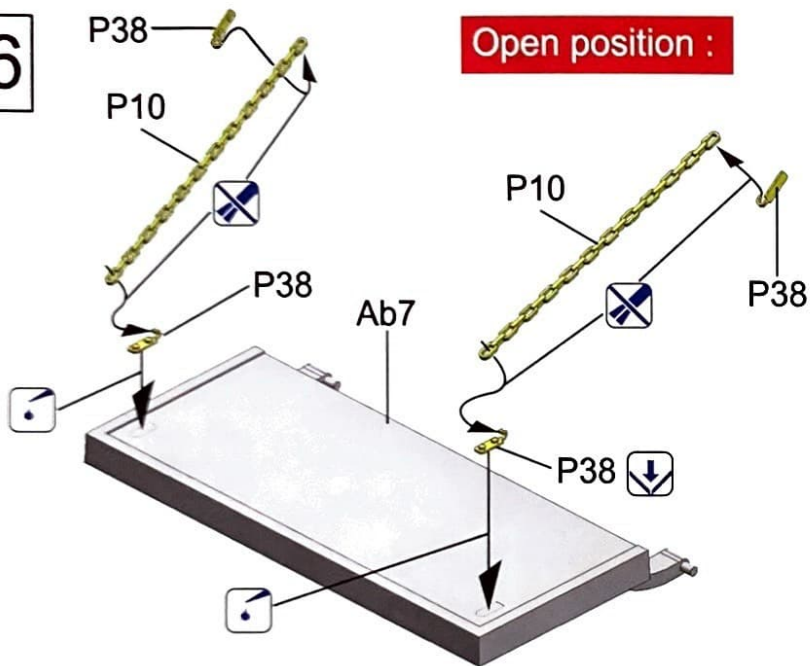

27

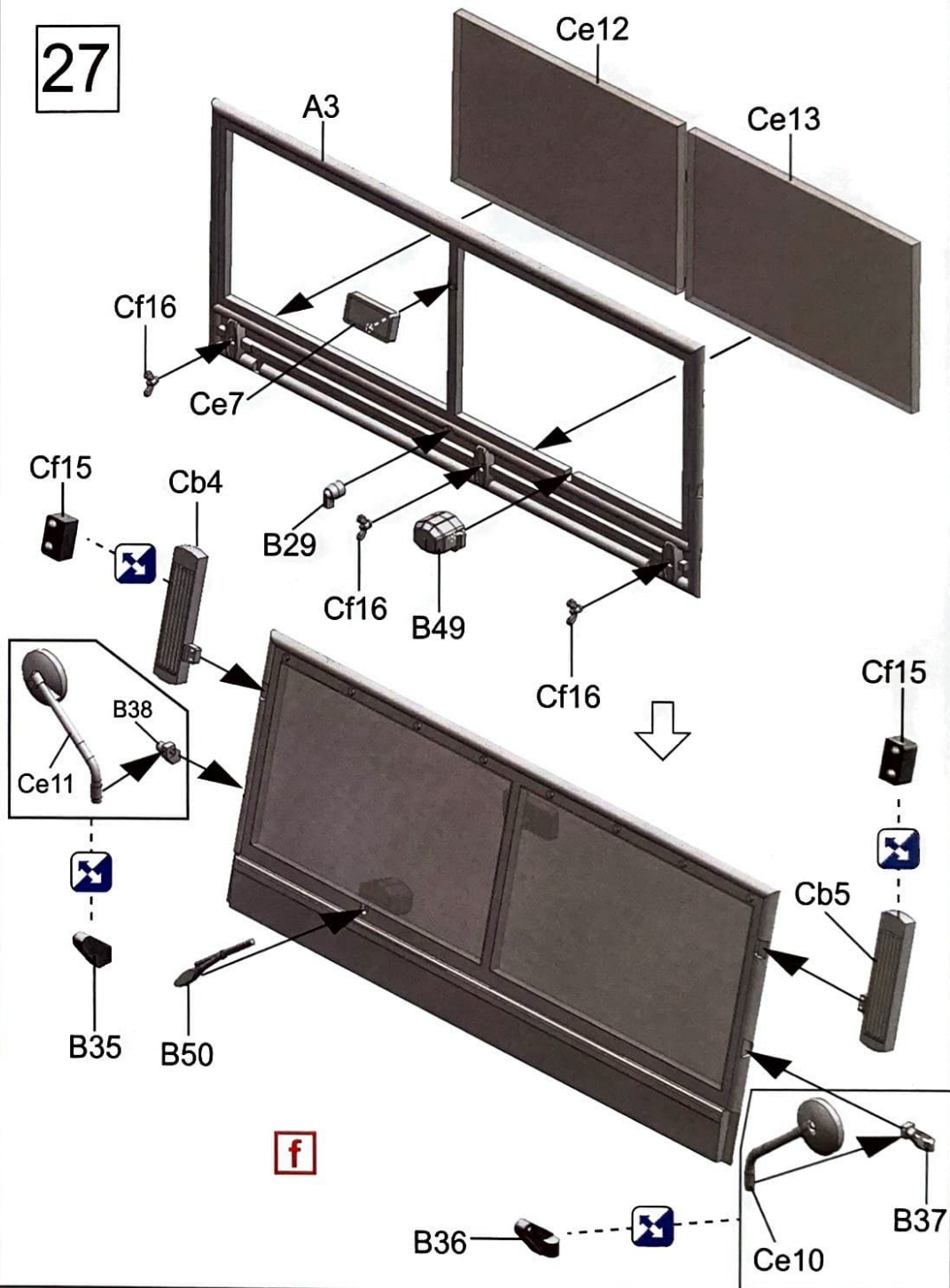

28

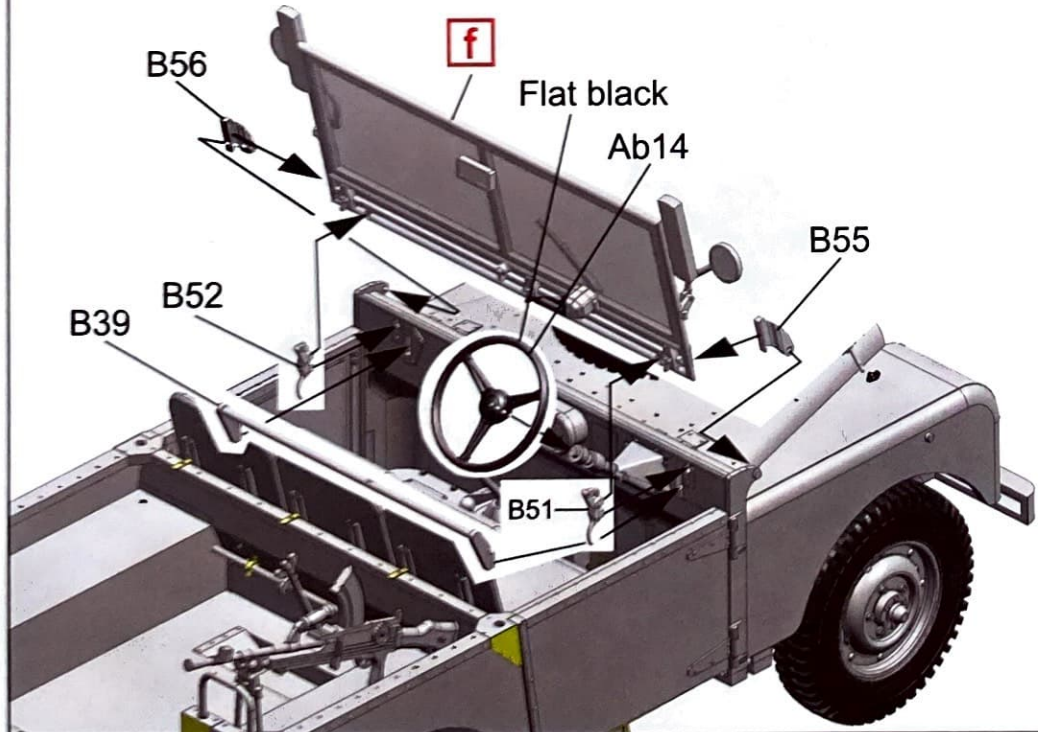
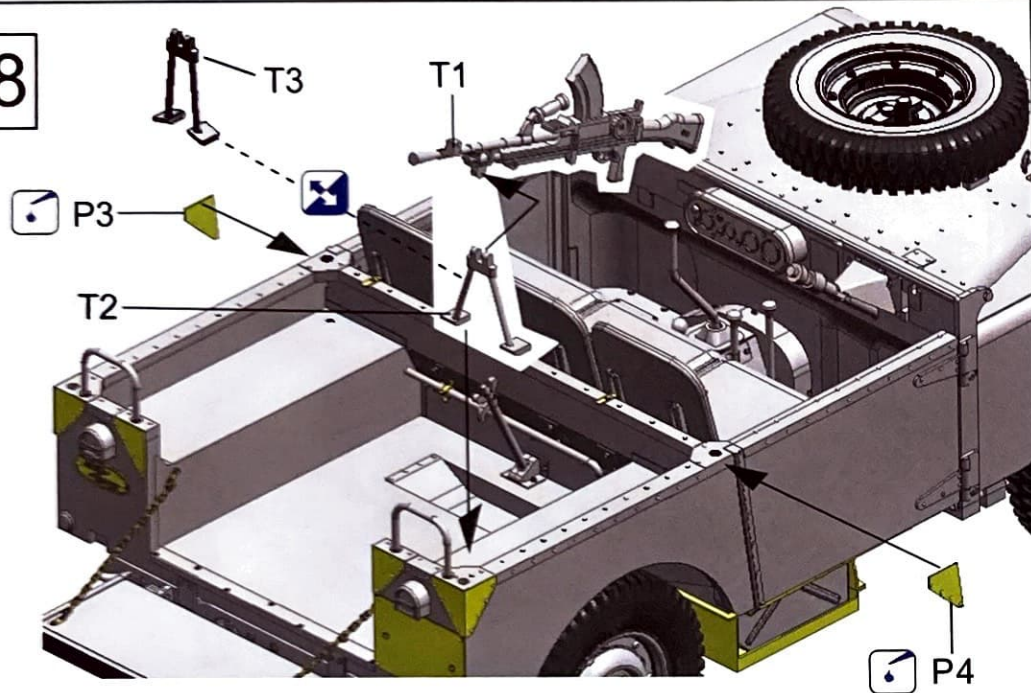

29

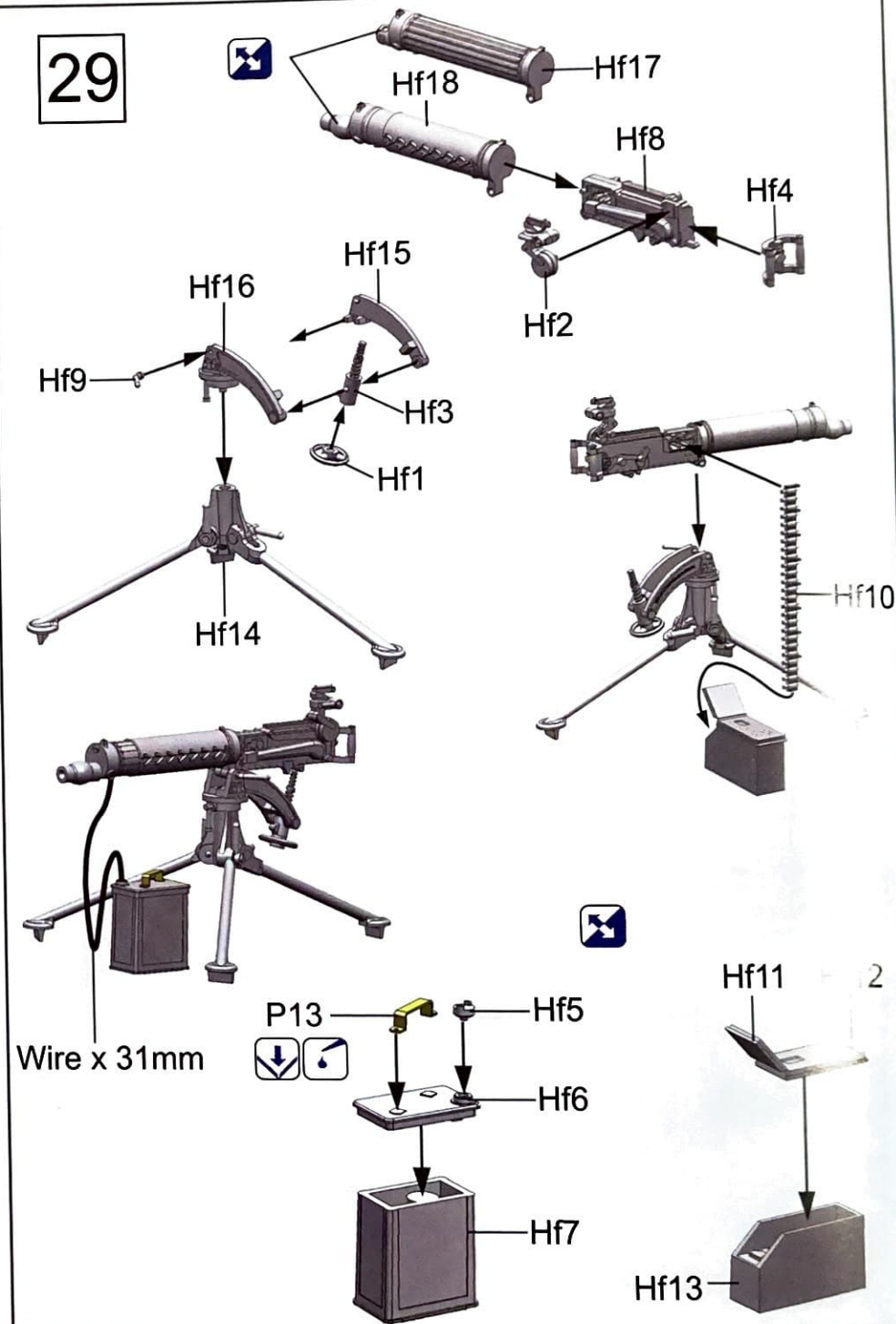

30

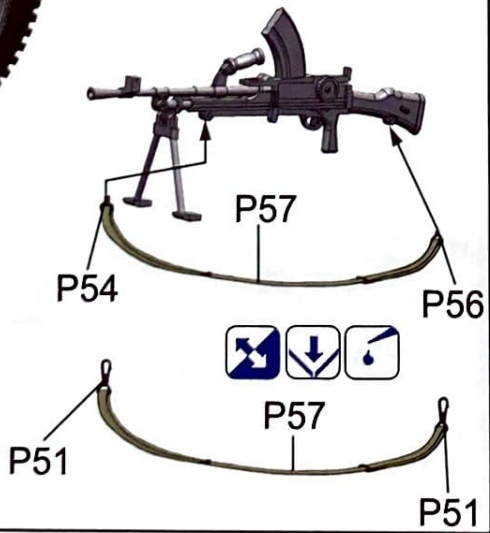
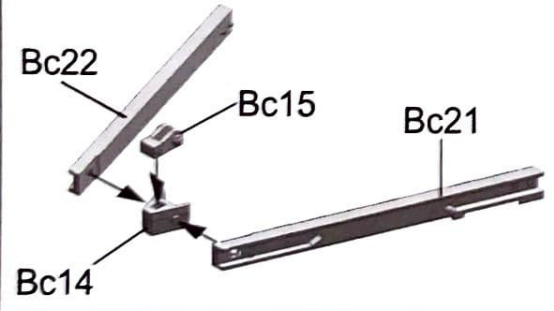
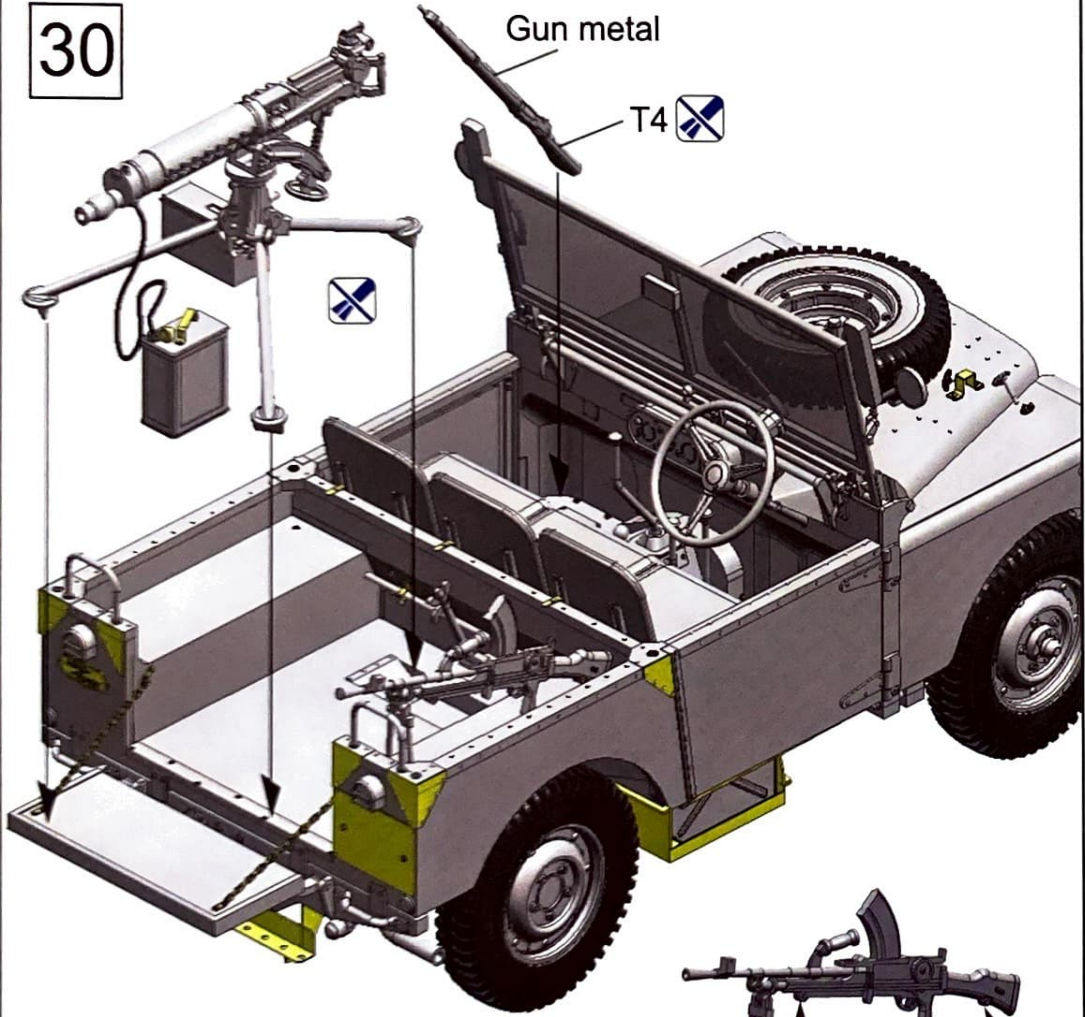

31

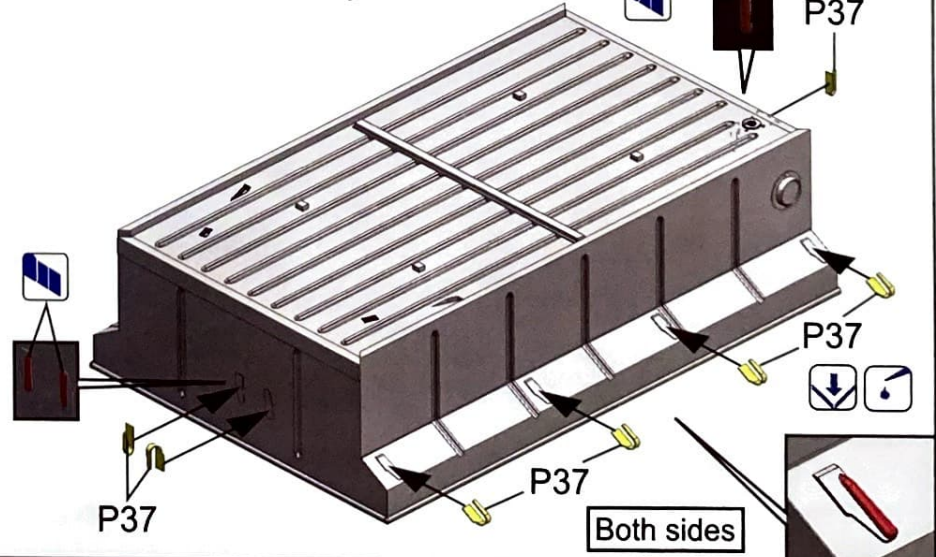
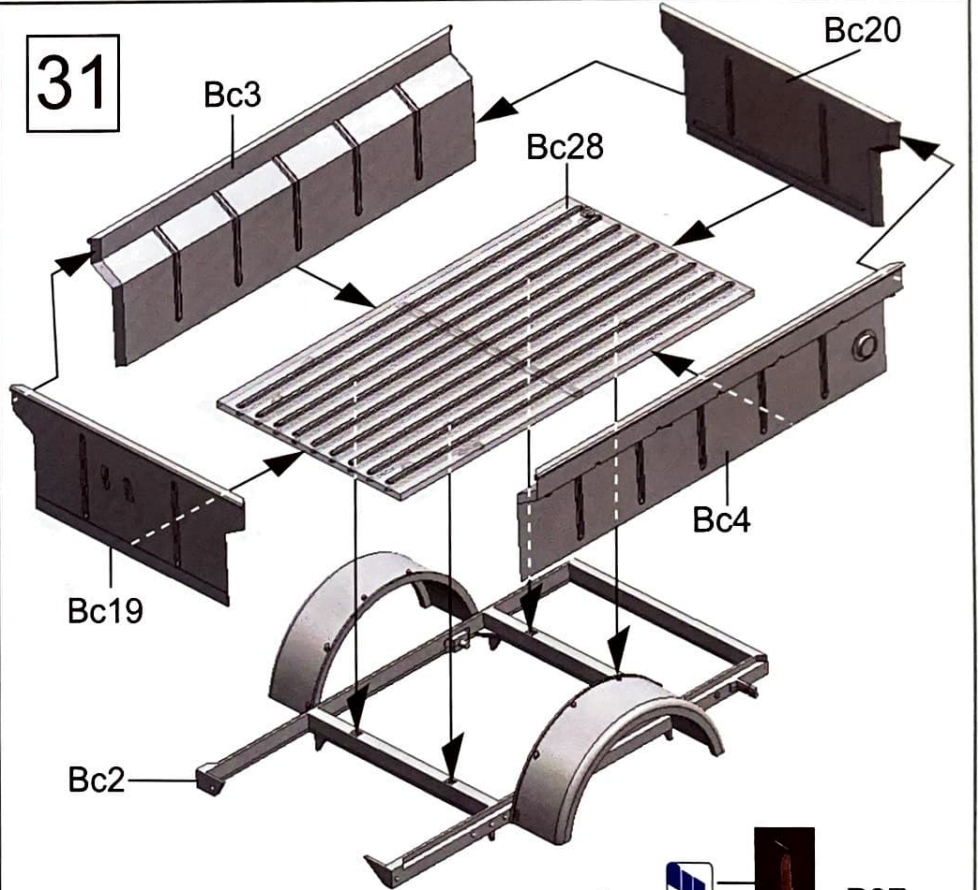

32

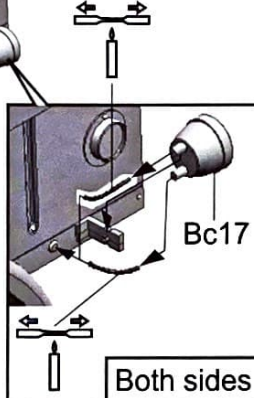
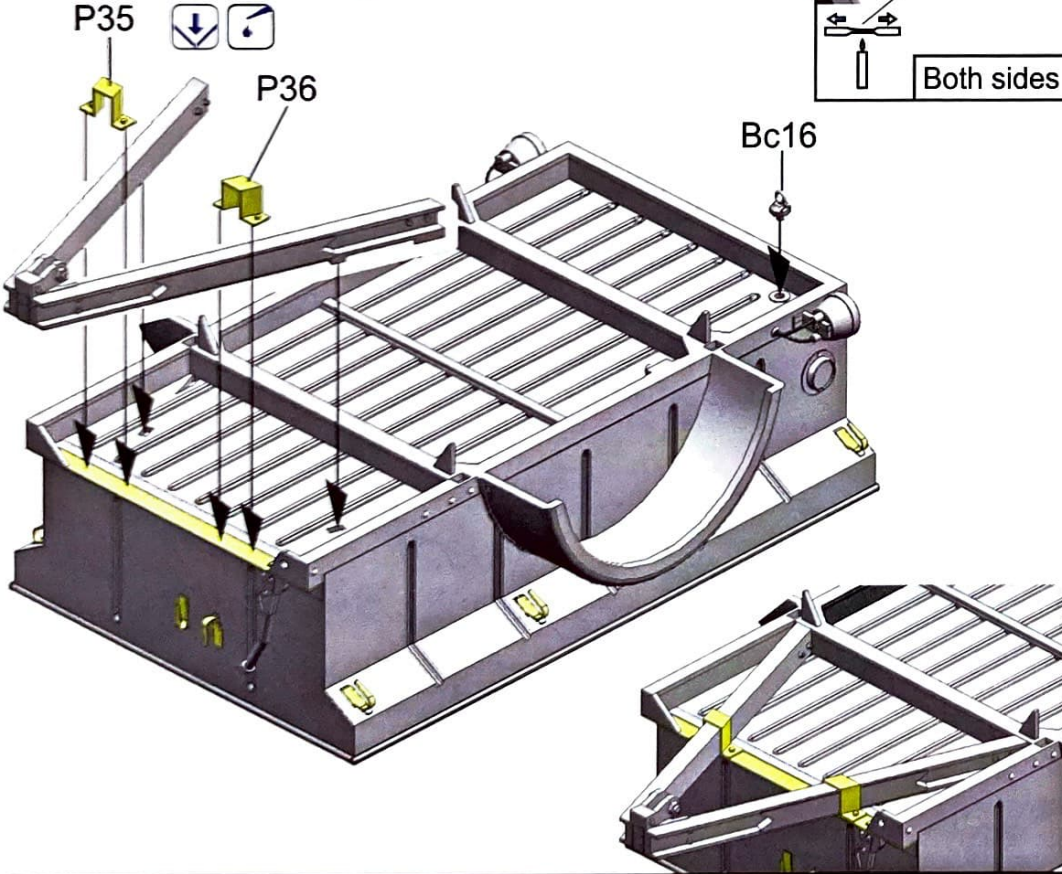
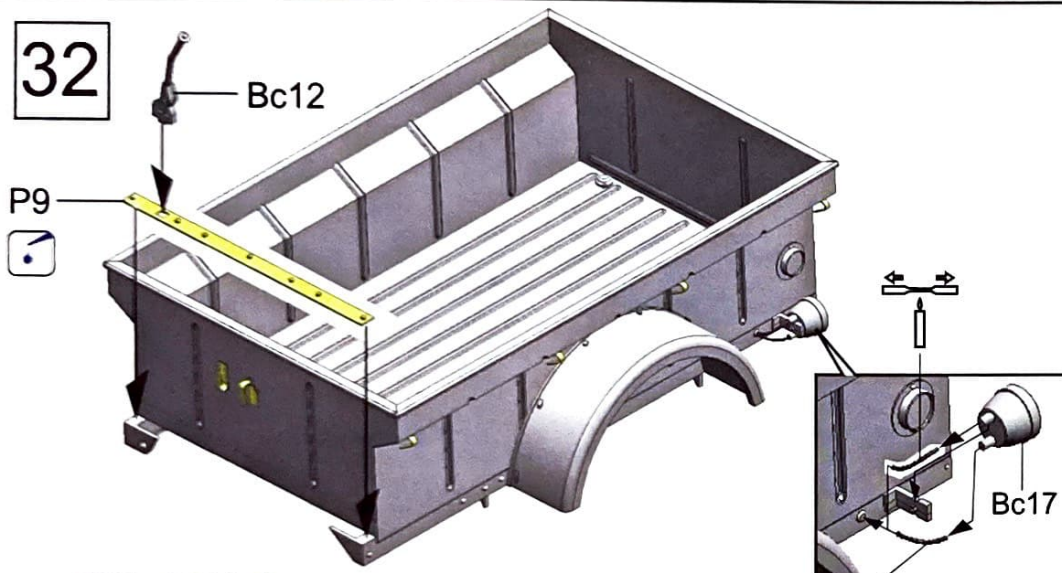

33

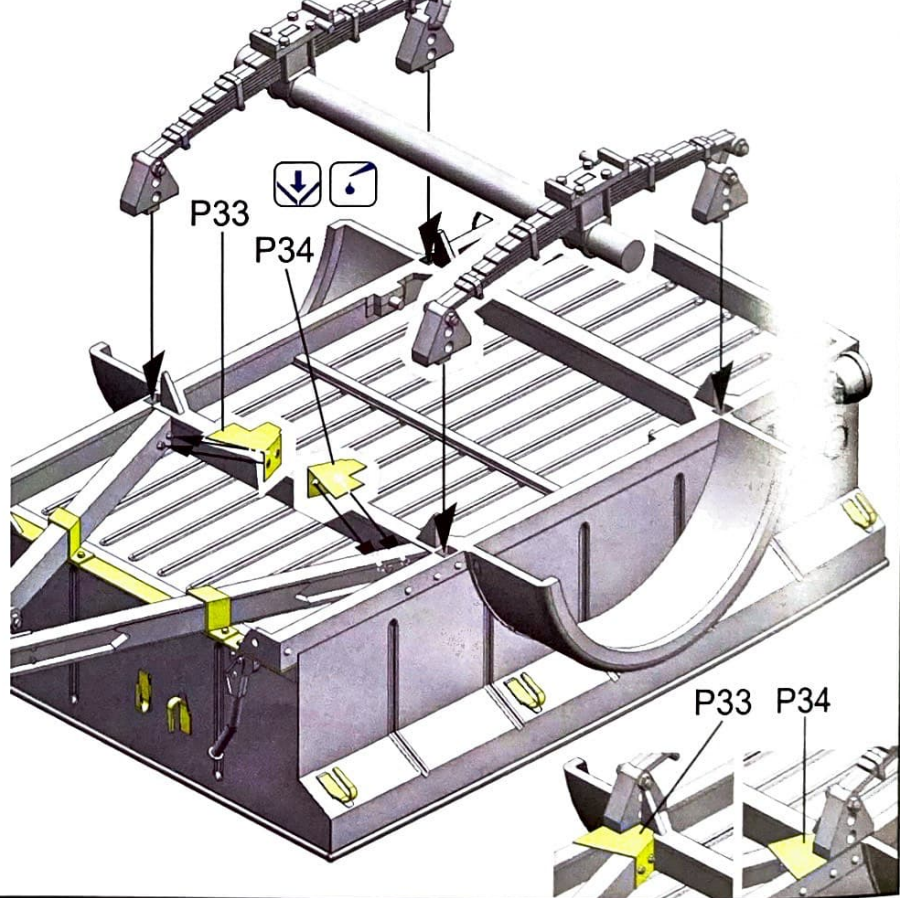
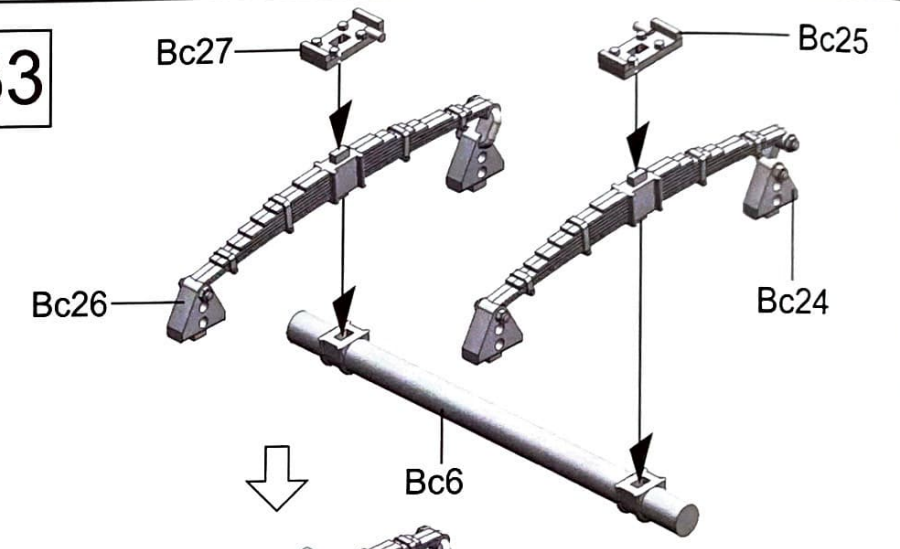

34

Note: To create the antennas, using a small flame, heat and stretch a section of the kit sprue. Use caution with open flame.

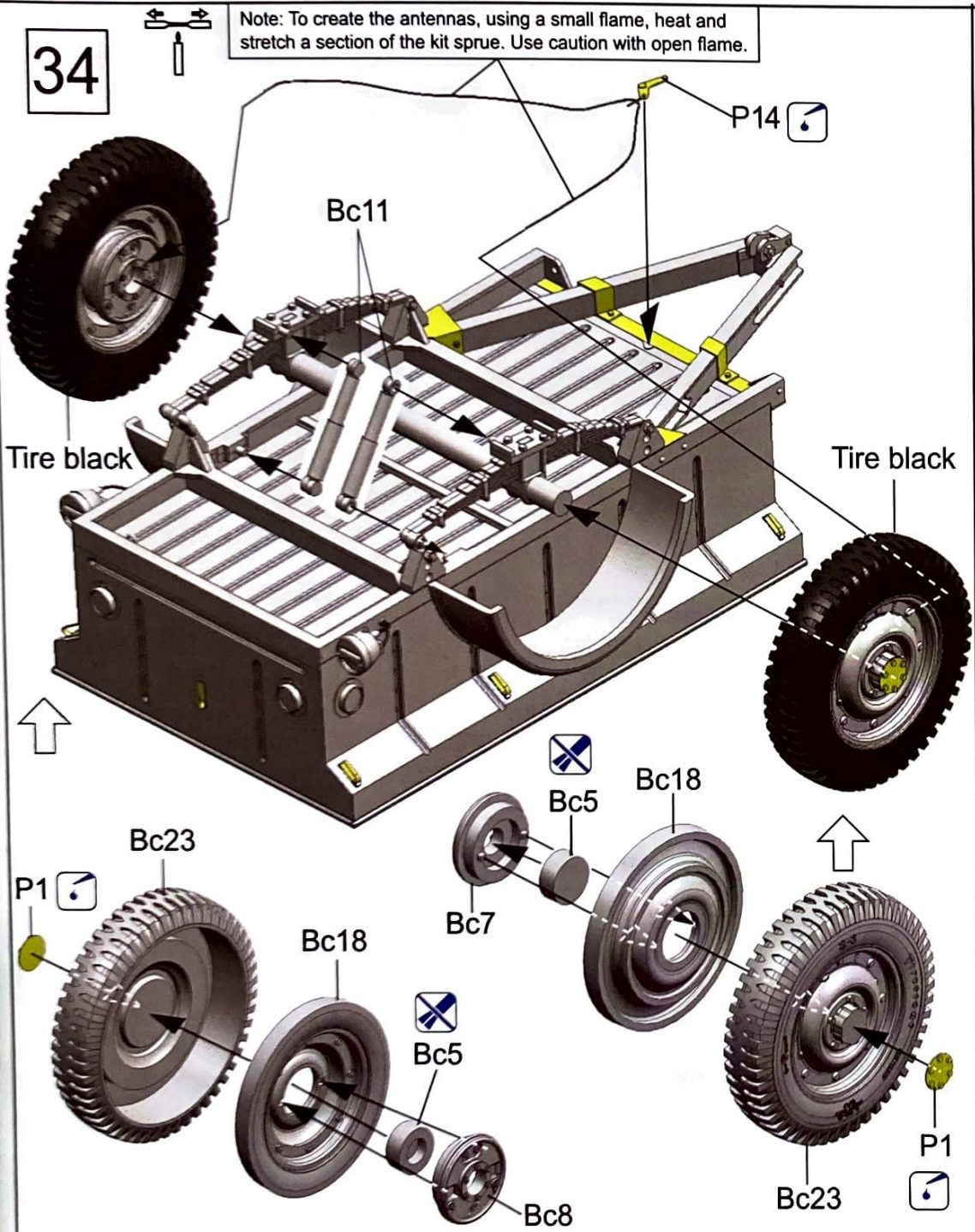

35

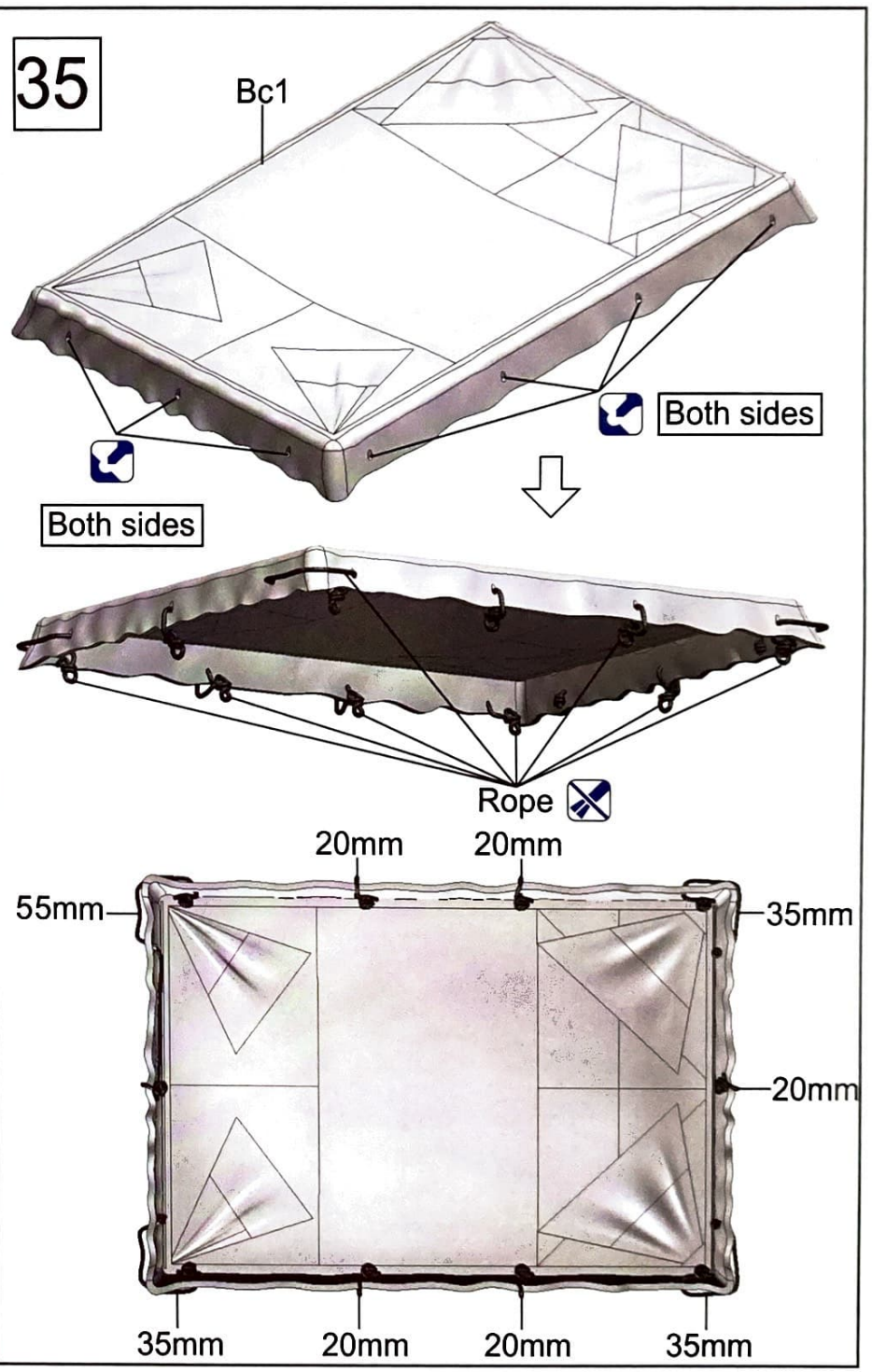

36



Both sides



37

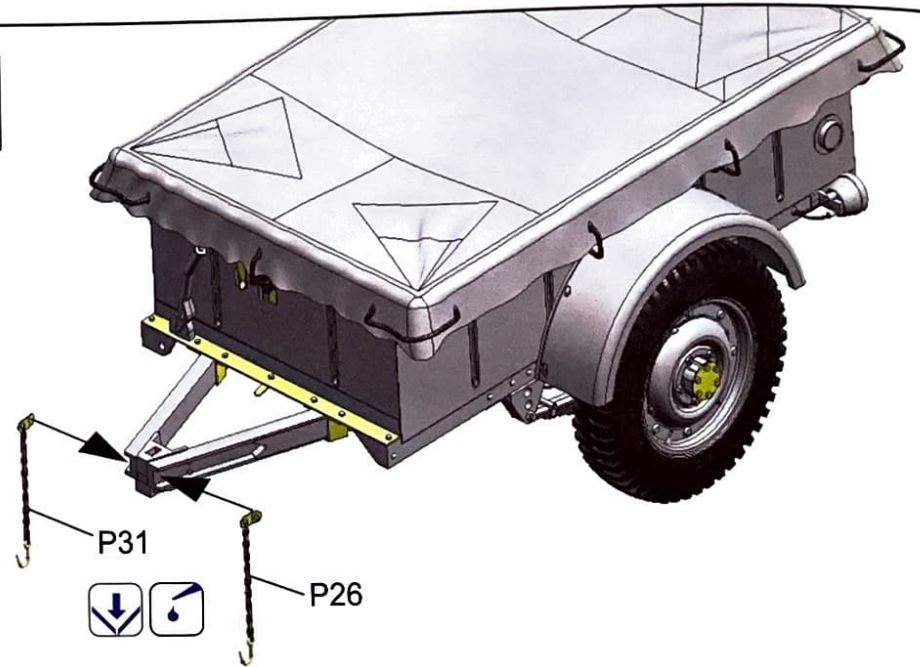

Additional Parts

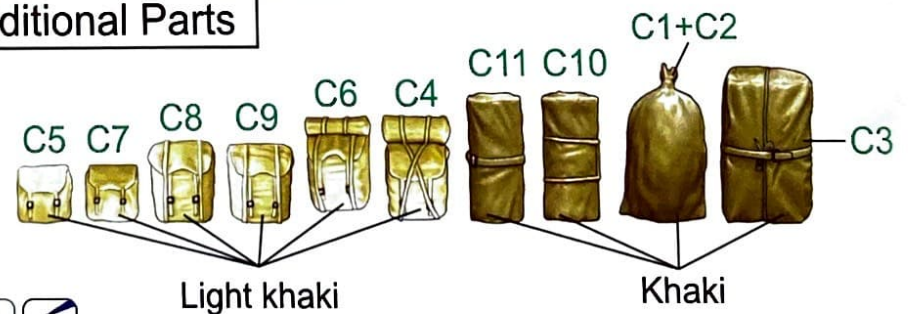

P50

D4

x6

D2

D3

P49

D5

D1

D6

x2

Olive green

Olive green

38

Option 1:

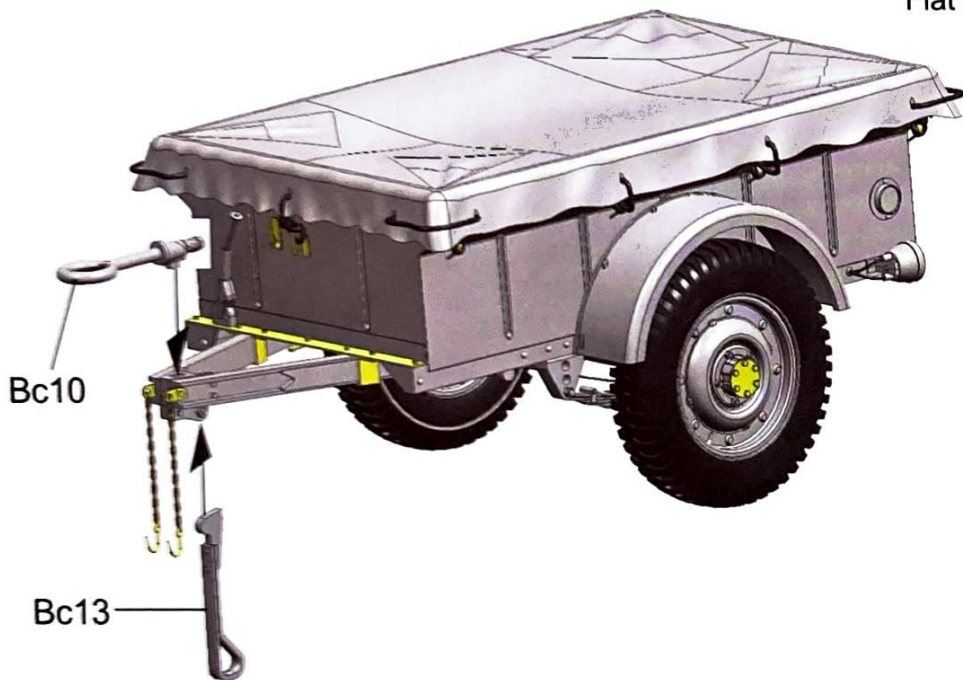

Option 2:

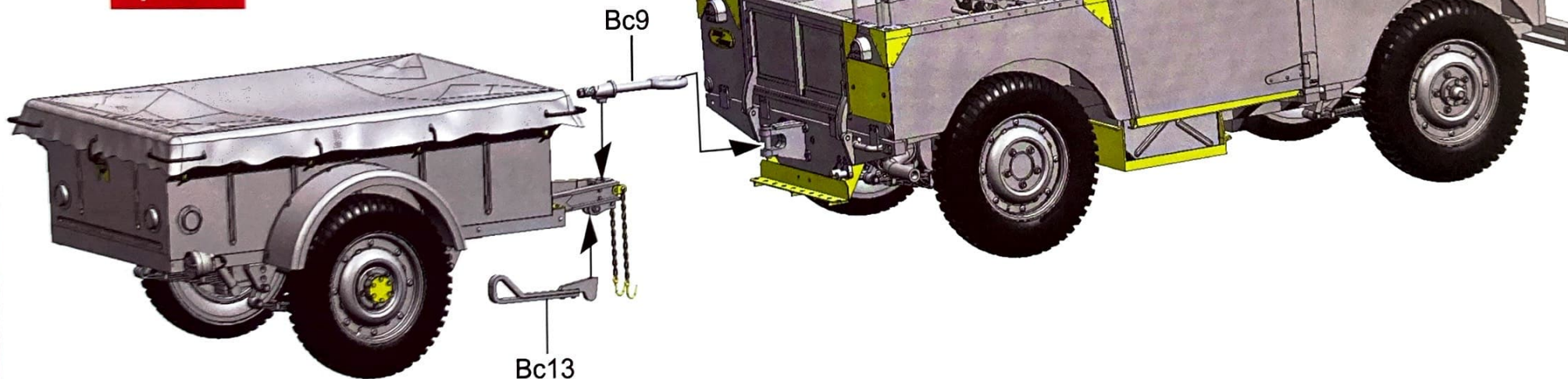

Option 1: British 29th Independent Infantry Brigade, Korea Dec, 1950

MISSION MODELS

PREMIUM HOBBY PAINTS & PRODUCTS

| | | | |
|-------------|---------|--------------|---------|
| Olive green | MMP-025 | Clear orange | MMP-171 |
| Silver | MMM-006 | Clear red | MMP-167 |
| Flat black | MMS-001 | Aluminum | MMM-008 |
| Gun metal | MMM-010 | Tire black | MMP-040 |
| Khaki | MMP-039 | Wood brown | MMP-002 |

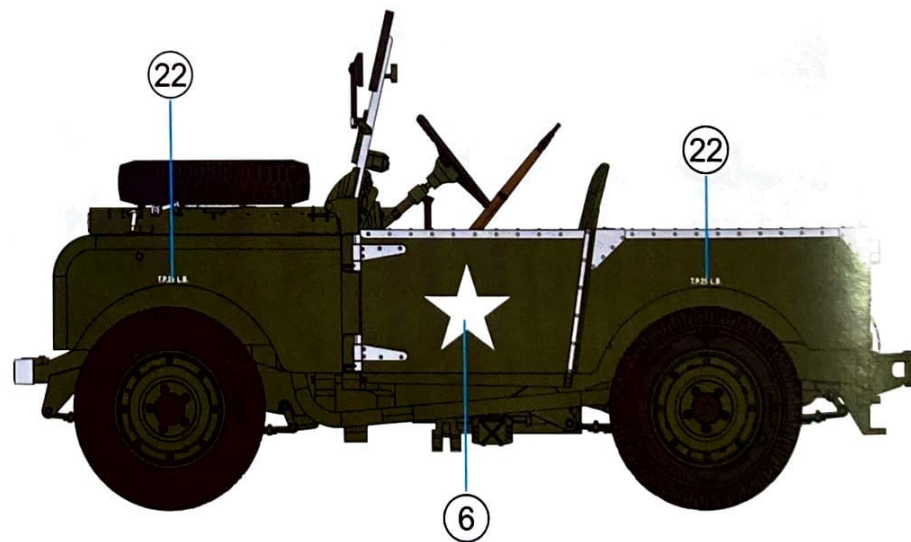
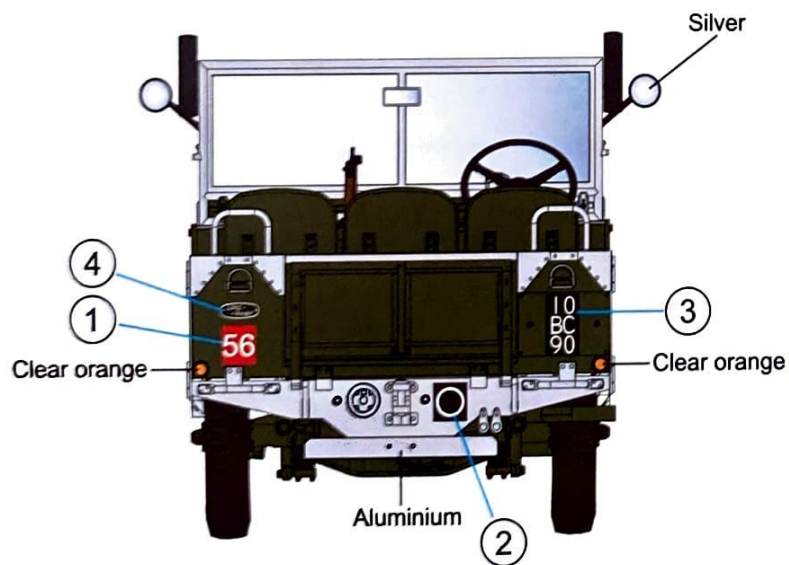
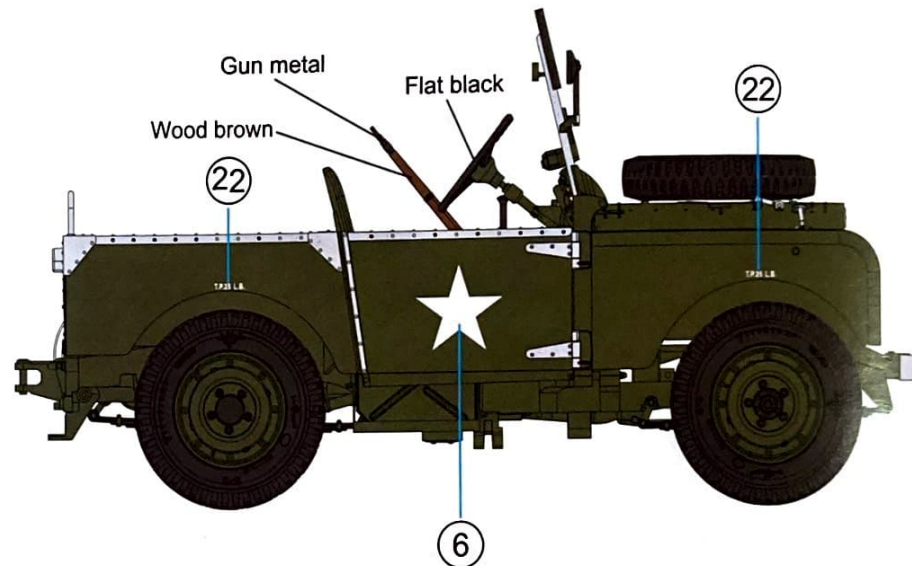
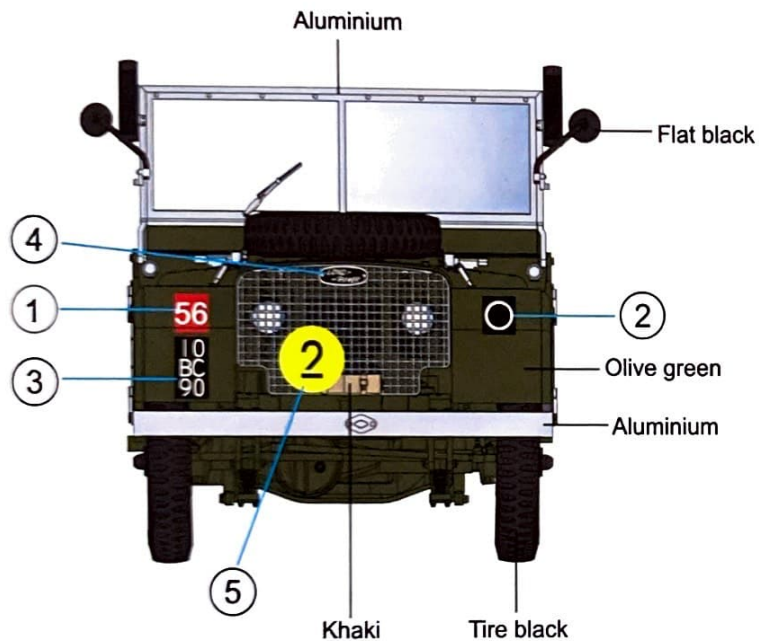

Option 2: US 14th Engineer Battallion, Pyongyang NorthKorea. Oct 1950

MISSION MODELS
PREMIUM HOBBY PAINTS & PRODUCTS
MADE IN USA

| | | | |
|-------------|---------|--------------|---------|
| Olive green | MMP-025 | Clear orange | MMP-171 |
| Silver | MMM-006 | Clear red | MMP-167 |
| Flat black | MMS-001 | Aluminum | MMM-008 |
| Gun metal | MMM-010 | Tire black | MMP-040 |
| Khaki | MMP-039 | Wood brown | MMP-002 |

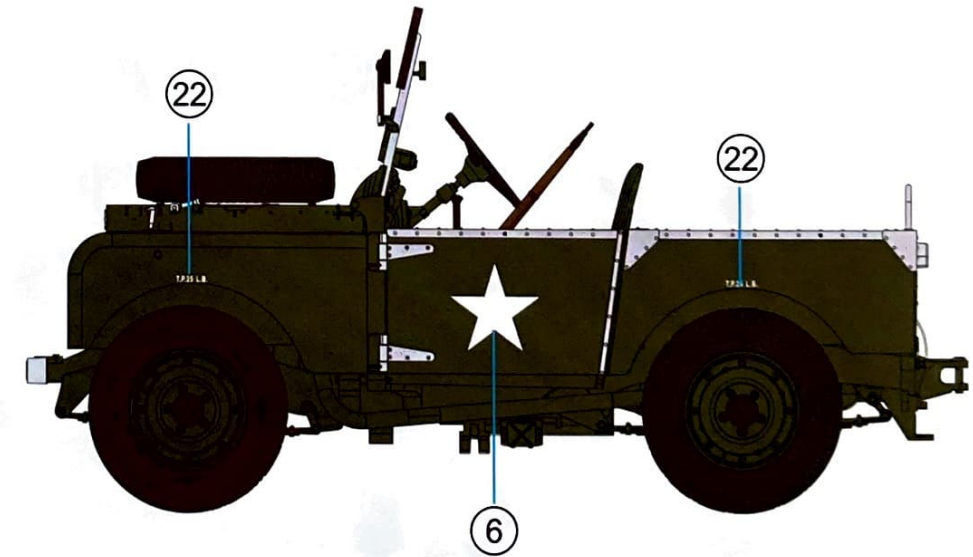
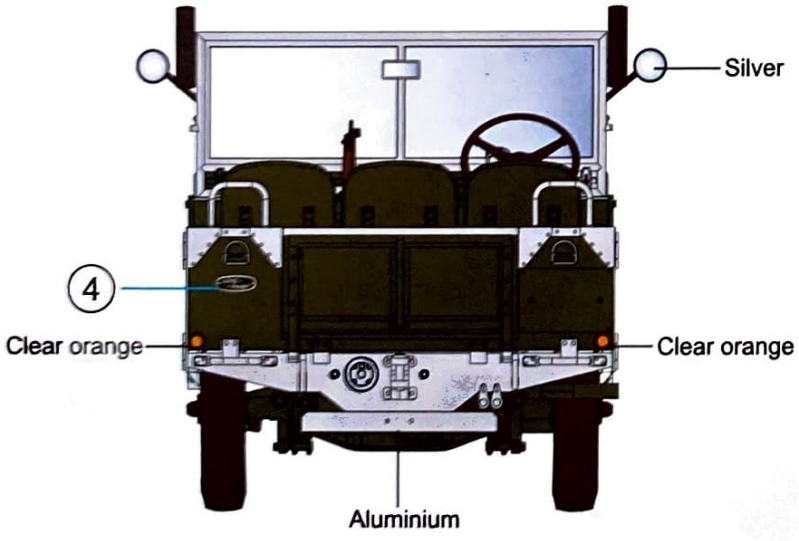
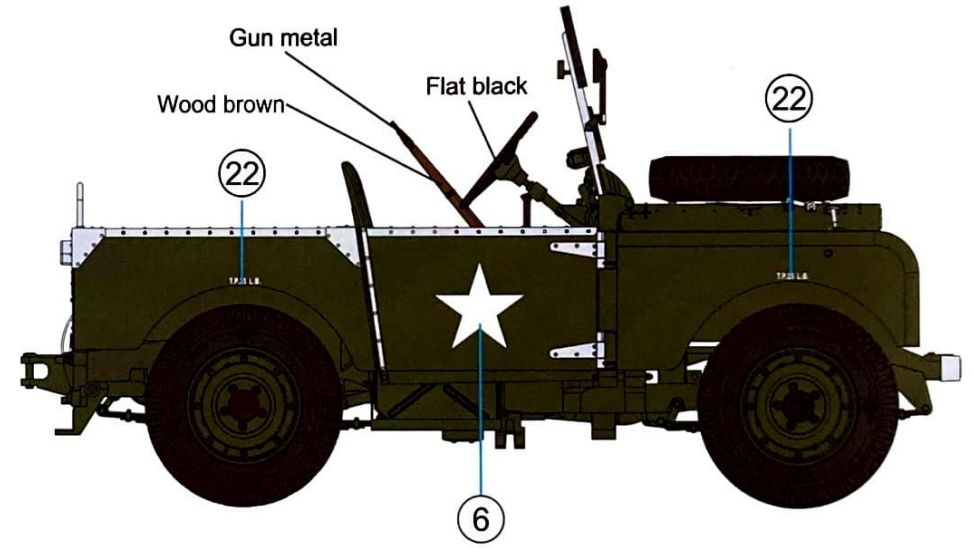
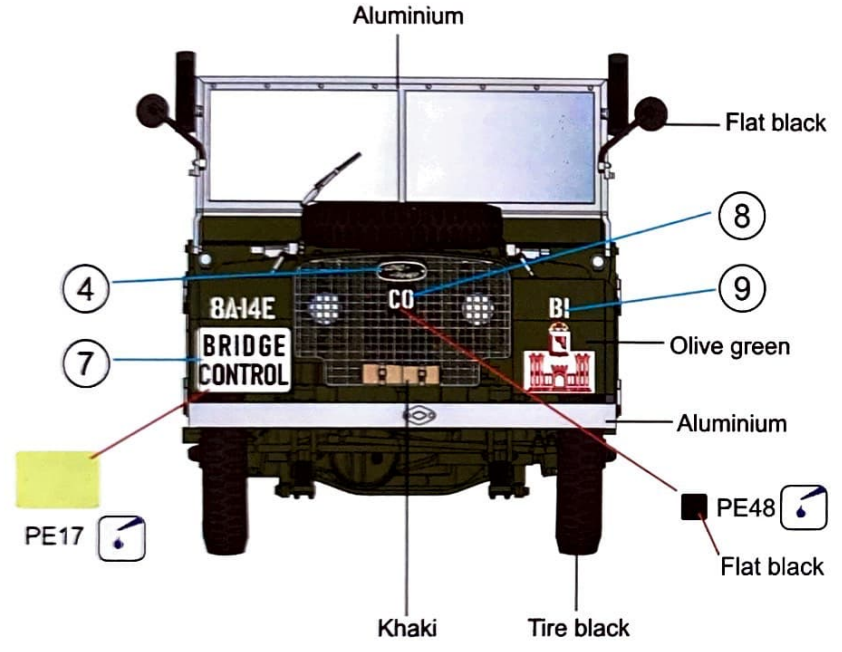

Option 3: British Army in Pusan Korea, 1950

MISSION MODELS

PREMIUM HOBBY PAINTS & PRODUCTS

| | | | |
|-------------|---------|--------------|---------|
| Olive green | MMP-025 | Clear orange | MMP-171 |
| Silver | MMM-006 | Clear red | MMP-167 |
| Flat black | MMS-001 | Aluminum | MMM-008 |
| Gun metal | MMM-010 | Tire black | MMP-040 |
| Khaki | MMP-039 | Wood brown | MMP-002 |

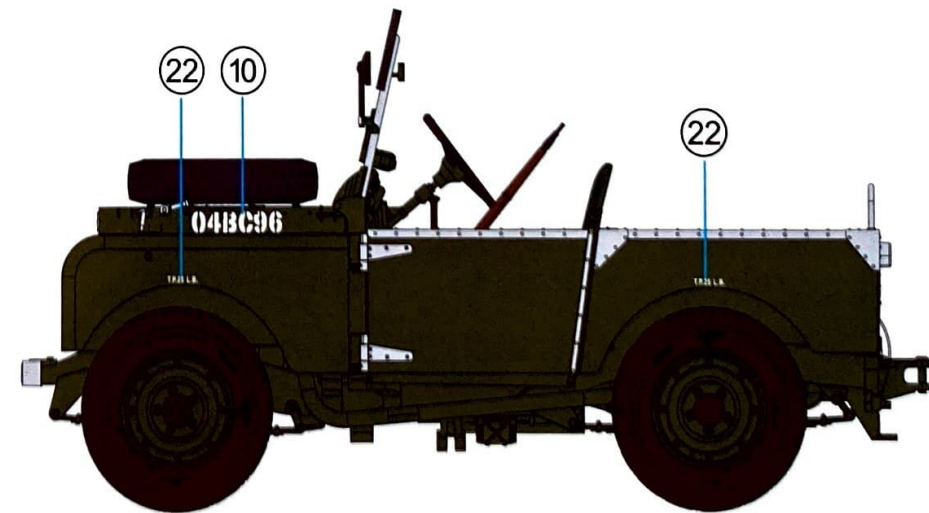
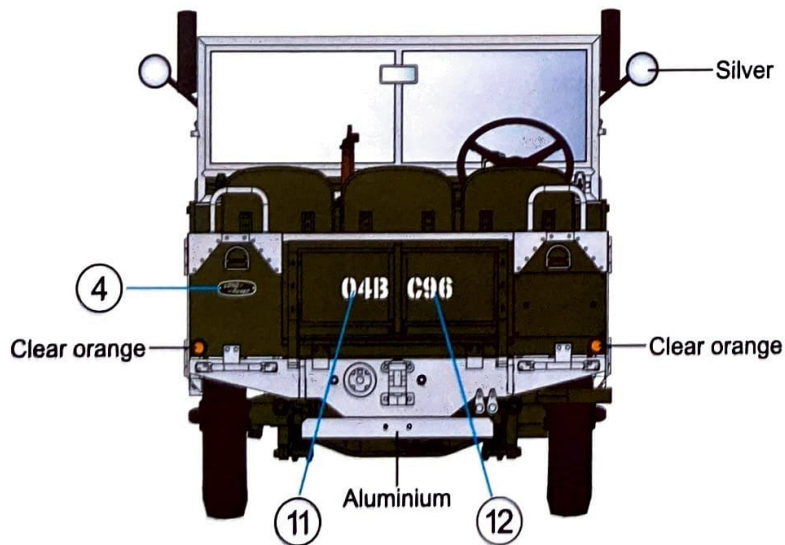
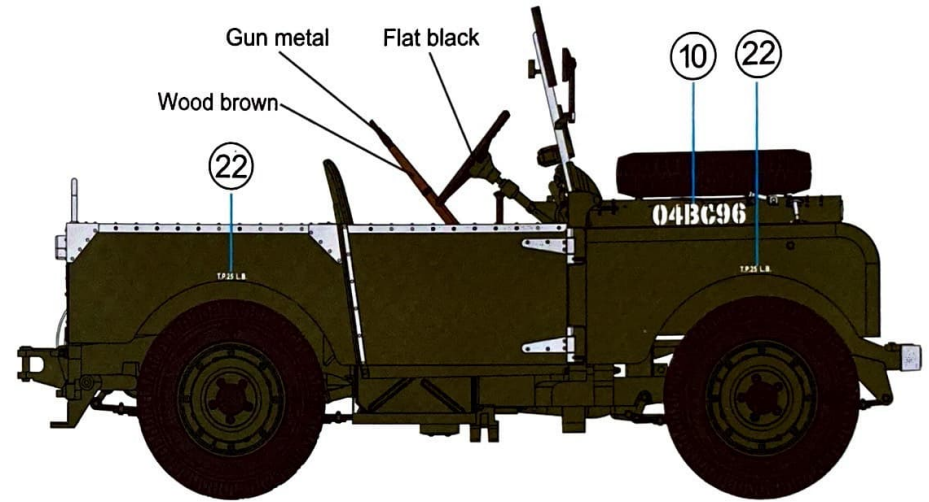
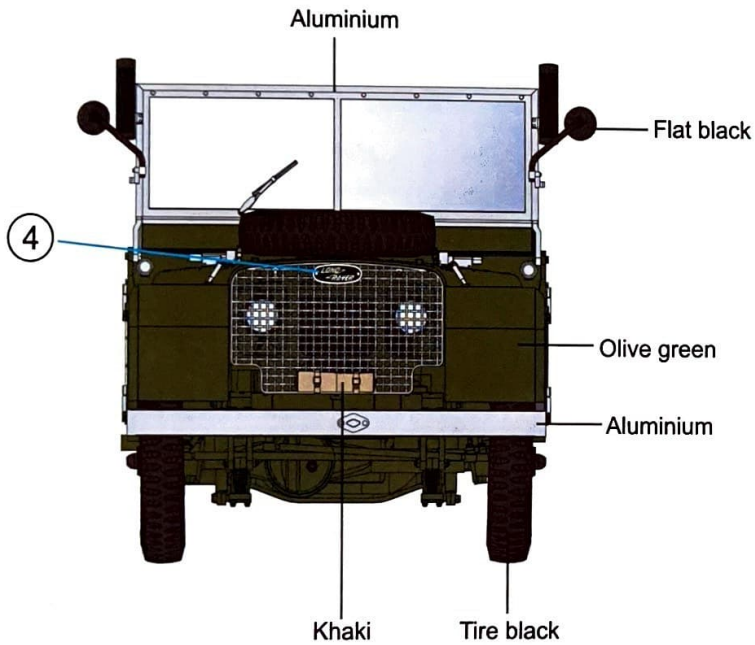

Option 4: British Army Trial Vehicle in England, 1949

MISSION MODELS
PREMIUM HOBBY PAINTS & PRODUCTS
MADE IN USA

| | | | |
|-------------|---------|--------------|---------|
| Olive green | MMP-025 | Clear orange | MMP-171 |
| Silver | MMM-006 | Clear red | MMP-167 |
| Flat black | MMS-001 | Aluminum | MMM-008 |
| Gun metal | MMM-010 | Tire black | MMP-040 |
| Khaki | MMP-039 | Wood brown | MMP-002 |

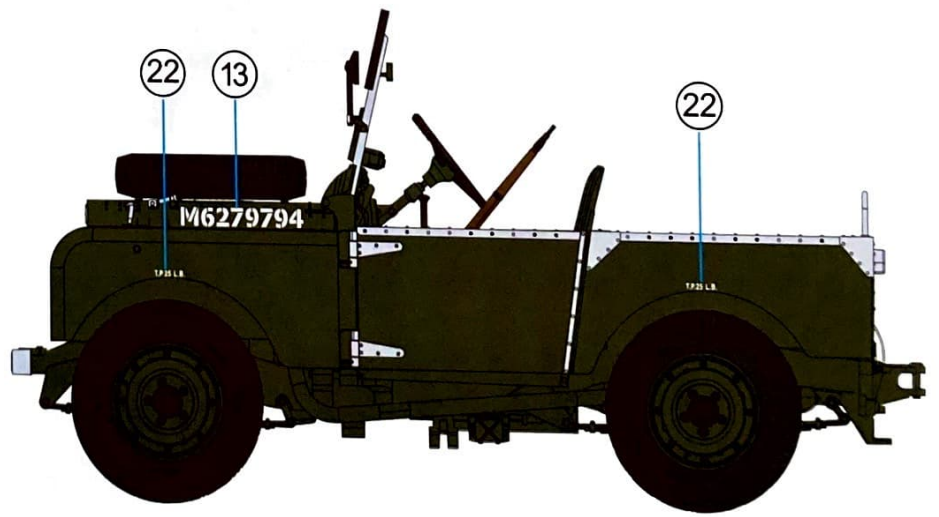
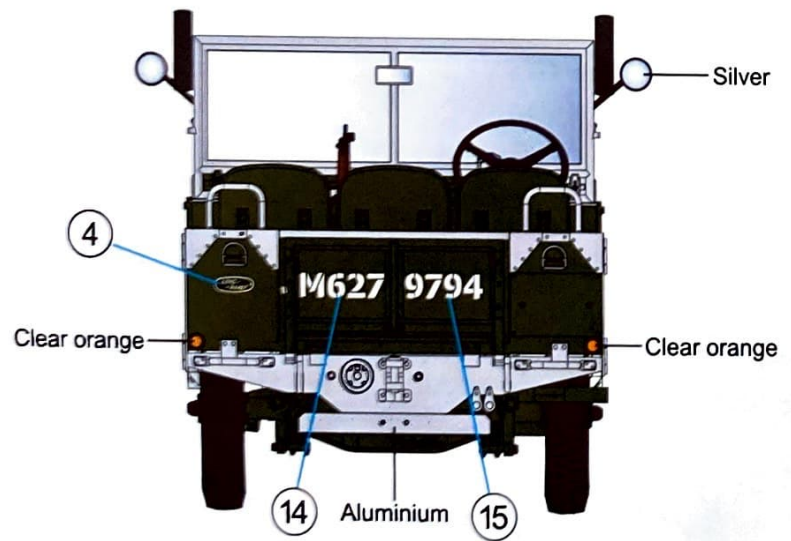
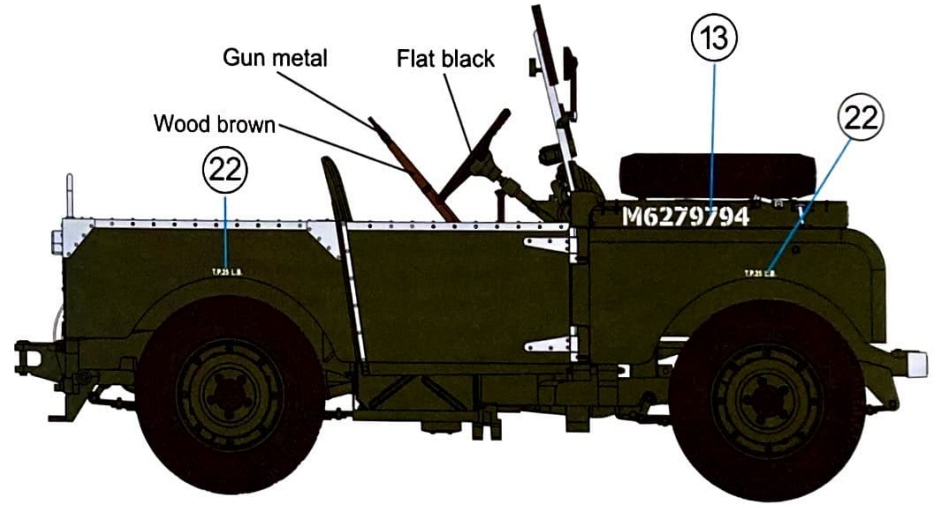
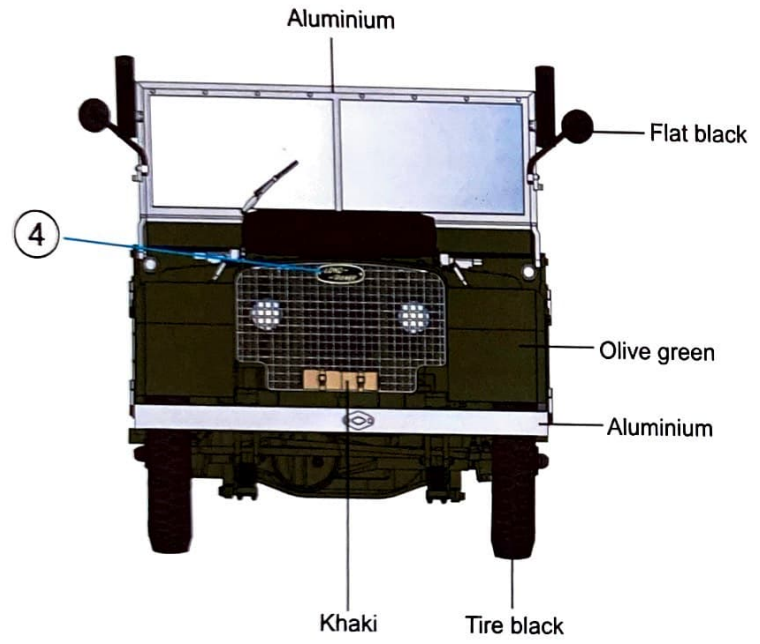

Option 1 :

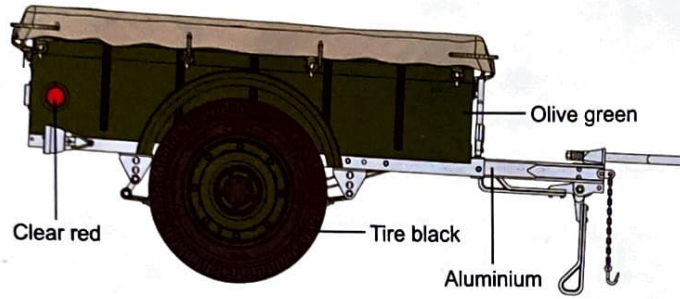
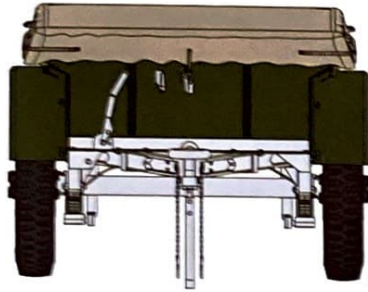

MISSION MODELS

PREMIUM HOBBY PAINTS & PRODUCTS
MADE IN USA

| | | |
|--------------|--|---------|
| Olive green | | MMP-025 |
| Silver | | MMM-006 |
| Flat black | | MMS-001 |
| Gun metal | | MMM-010 |
| Khaki | | MMP-039 |
| Clear orange | | MMP-171 |
| Clear red | | MMP-167 |
| Aluminium | | MMM-008 |
| Tire black | | MMP-040 |
| Wood brown | | MMP-002 |

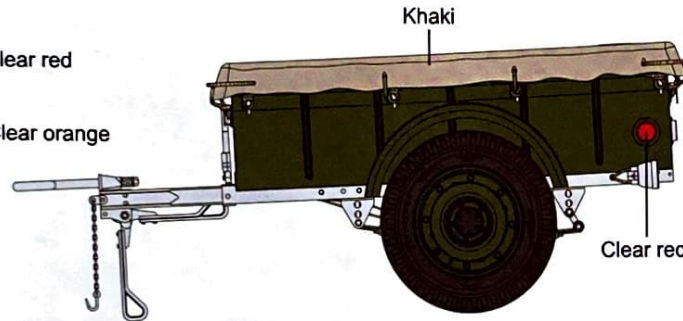
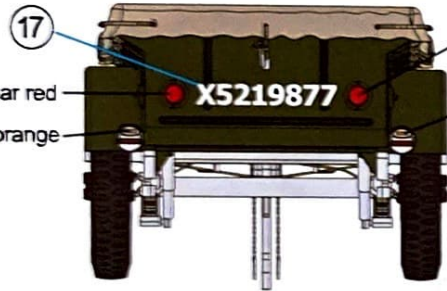

Option 2 :

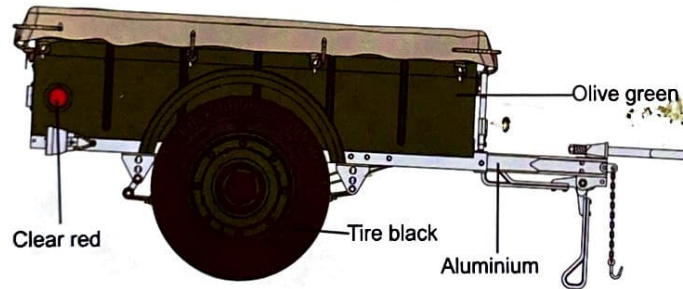
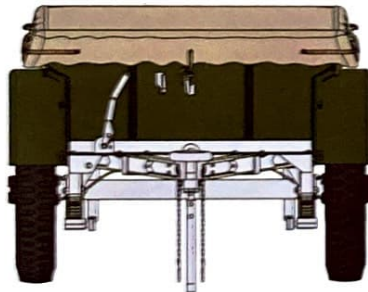

MISSION MODELS

PREMIUM HOBBY PAINTS & PRODUCTS
MADE IN USA

| | | |
|--------------|--|---------|
| Olive green | | MMP-025 |
| Silver | | MMM-006 |
| Flat black | | MMS-001 |
| Gun metal | | MMM-010 |
| Khaki | | MMP-039 |
| Clear orange | | MMP-171 |
| Clear red | | MMP-167 |
| Aluminium | | MMM-008 |
| Tire black | | MMP-040 |
| Wood brown | | MMP-002 |

