

Revell

Dassault MYSTÈRE IV A

04320-0389

©2003 BY REVELL AG.

PRINTED IN GERMANY

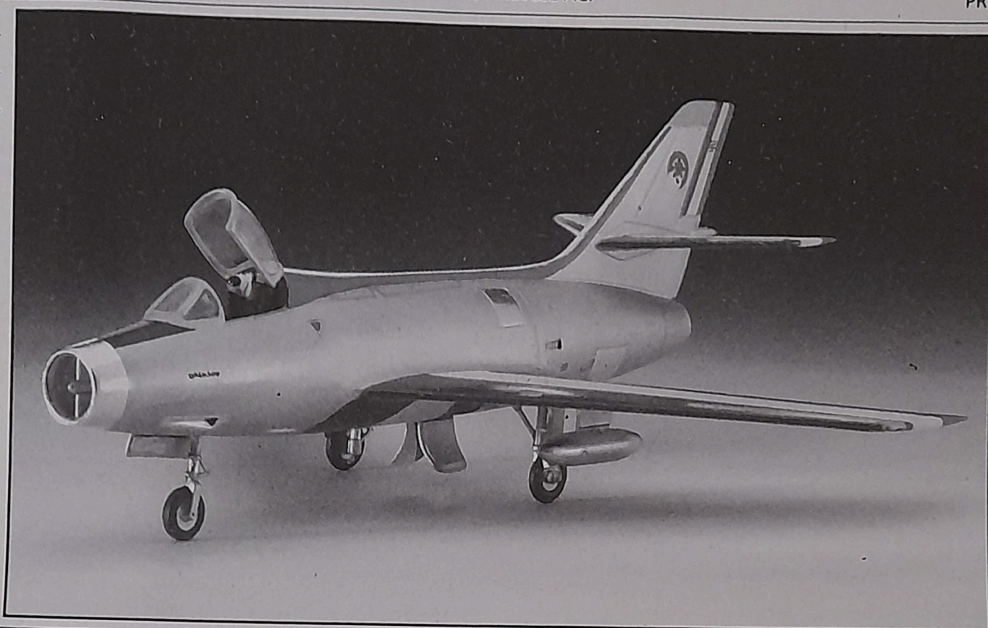

Dassault MYSTÈRE IV A

Eine der zahlreichen Jagdbomber- und Abfangjägerentwicklungen aus der mit Pfeilflügeln konstruierten Mystère basierte auf der älteren Dassault Ouragan, es war die einsitzige Mystère IVA und gleichzeitig die erfolgreichste Produktionsvariante. Der von einem Hispano Suiza Tay Triebwerk mit 2.850 kp (6.283 lbs.) Schub angetriebene Prototyp hob im September 1952 zum ersten Mal ab. Im Rahmen eines Auslands Beschaffungsprogramm das von den USA initiierte wurde, orderte man 1953 225 Maschinen, das erste Flugzeug der Bestellung flog bereits 1954. Die ersten 50 Flugzeuge wurden mit dem Tay 250A Triebwerk ausgeliefert, alle folgenden erhielten das stärkere Hispano Suiza Verdon 350 Triebwerk mit 3.500 kp (7.717 lbs.) Schub. Die französische Regierung bestellte weitere 100 Flugzeuge und die Mystère wurde 1954 im großen Stil bei der französischen Luftwaffe eingeführt. Insgesamt standen 241 Jets bei verschiedenen Geschwadern in Dienst, später wurde sie als Trainingsflugzeug eingesetzt. Das berühmte "Patrouille de France" Kunstflugteam flog von den späten 50ern bis zu Beginn der 60er Jahre bunt bemalte Mystères. Die letzten Mystère IVA wurden bei der E.C. (T).8 eingesetzt, ehe sie 1982 durch Alpha Jets ersetzt wurden. Ab 1978 wurden viele der ausgemusterten Mystère, die durch das U.S. Beschaffungsprogramm geordert worden waren, an die US Airforce zurückgegeben. Indien und Israel, die vorher auch schon die Ouragans einsetzten, waren die einzigen Exportkunden. 1957 erhielt die indische Luftwaffe 110 Exemplare, Israel hatte schon 1956 60 Stück bekommen. In beiden Ländern wurde die Mystère mit großem Erfolg als Jagdbomber und Abfangjäger eingesetzt. Die Mystère IVA hatte eine Höchstgeschwindigkeit von 1.110 km/h (690 mph) auf Meereshöhe. Bewaffnet war sie mit einem Paar 30mm DEFA Kanonen und konnte mit Bomben oder mit Zusatztanks unter den Flügeln bestückt werden.

Flügelspannweite: 11,12 m
Länge: 12,89 m
Höhe: 4,60 m

Dassault MYSTÈRE IV A

One of several swept-wing Mystère fighter and fighter-bomber developments based on the earlier Dassault Ouragan, the single-seat Mystère IVA was the most successful production variant; powered by the Hispano Suiza Tay turbojet rated at 2,850kgp (6,283 lbs.) thrust, the prototype first flew in September 1952. In 1953, under a U.S. funded offshore procurement programme, 225 machines were ordered, the first one flying in 1954. The initial 50 aircraft retained the Tay 250A engine as standard, all subsequent aircraft having the more powerful Hispano Suiza Verdon 350 engine rated at 3,500 kgp (7,717 lbs.) thrust. The French government also ordered a further 100 machines and the type entered large scale service with the Armée de l'Air from 1954, a total of 241 serving with the various operational squadrons of Nos. 2, 5, 7, 8, 10 and 12 Wings and later used in the training role. During the late 1950s and early 1960s the famous 'Patrouille de France' aerobatic team also flew colourfully painted Mystères. The last Mystère IVAs served with E.C.(T).8 until they were replaced by Alpha Jets from 1982. By 1978 many of the retired aircraft, originally ordered under the U.S. funded programme, were transferred to USAF ownership. India and Israel, which had both used large numbers of Ouragans, were the only export customers for the type; from 1957 the Indian Air Force received 110 aircraft and Israel received 60 of the type from 1956, both countries using them to great effect in both the fighter and fighter-bomber roles during the following years. The Mystère IVA had a maximum speed of 1,110km/h (690mph) at sea level; it was armed with a pair of 30mm DEFA cannons and could carry underwing fuel tanks or bombs.

Wing span: 11.12 m (36 ft 5.75 in.)
Length: 12.89 m (42 ft 3.5 in.)
Height: 4.60 m (15 ft 1 in.)

Form hergestellt und im Eigentum von Revell AG/Revell Monogram Inc. Widerrechtliche Nachahmungen werden gerichtlich verfolgt.
Ce produit est propriété de la société Revell AG/Revell Monogram Inc. Toute utilisation ou duplication frauduleuse fera l'objet de poursuites en justice.

Modelado y en propiedad de Revell AG/Revell Monogram Inc. Imitaciones ilícitas serán perseguidas por la ley.
Forma prodotta dalla Revell AG/Revell Monogram Inc. e di proprietà della stessa impresa, la quale procederà legalmente contro ogni imitazione abusiva.

Malli on Revell AG/Revell Monogram Inc. valmistama ja omaisuus. Laittomaan kopiointiin tullaan puuttamaan oikeudellisin toimin.
Formen er produsert og eies av Revell AG/Revell Monogram Inc. Etterfigning uten tillatelse vil bli gjenstand for rettslig forfølgelse.
Produkcja i prawa własności firmy Revell AG/Revell Monogram Inc. Nielegalne podrobienie jest zabronione pod odpowiedzialnością sądowną.
Model, Revell AG/Revell Monogram Inc. firmasının mülkiyeti altında imal edilmiştir. Kanuna aykırı taklitler mahkemece takip edilecektir.
A forma előállításja és a tulajdonjog birtokosa a Revell AG/Revell Monogram Inc. A jogellenes utánzatokat és hamisítványokat bíróságilag üldözik.

Mould manufactured by and property of Revell AG/Revell Monogram Inc. Illegal imitations are subject to prosecution.

Vorm vervaardigd door en eigendom van Revell AG/Revell Monogram Inc. Onrechtmatige nabootsingen worden gerechtelijk vervolgd.
Formas produzidas e de propriedade da Revell SA/Revell Monogram Inc. Cópias não autorizadas serão processadas juridicamente como determinado na lei.

Modellen tillverkad av och tillhör Revell AG/Revell Monogram Inc. All kopiering beivras enligt lagen om upphovsrätt.
Formen er fremstillet af Revell AG/Revell Monogram Inc. som også har ejendomsret. Lovstridige efterfigninger sagsages.
Μοδελή κατασκευάστηκε και περιήλθε στην ιδιοκτησία της Revell AG/Revell Monogram Inc. Οι παράνομες μιμήσεις θα καταδικαστούν δικαστικά.
Tvar byl vytvořen firmou Revell AG/Revell Monogram Inc. a je jejím vlastnictvím. Proti nezákonným napodobením se bude postupovat soudní cestou.
Forma je proizvedena in je vlasništvo Revell AG/Revell Monogram Inc. Neovlaštene kopije bodo pravno kažnjene.

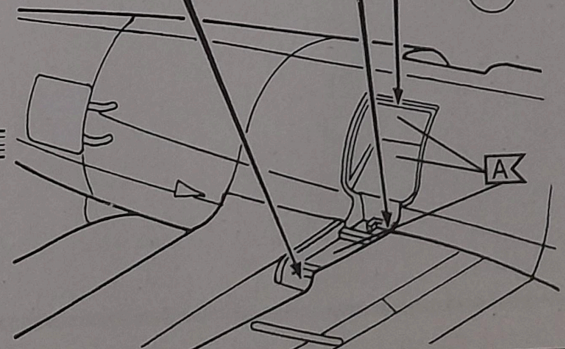
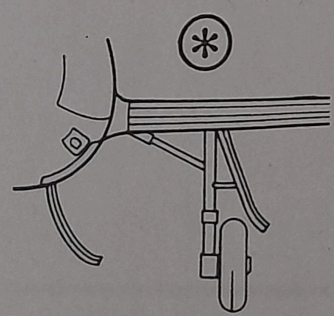
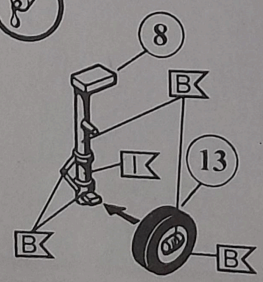
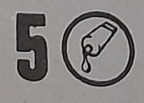
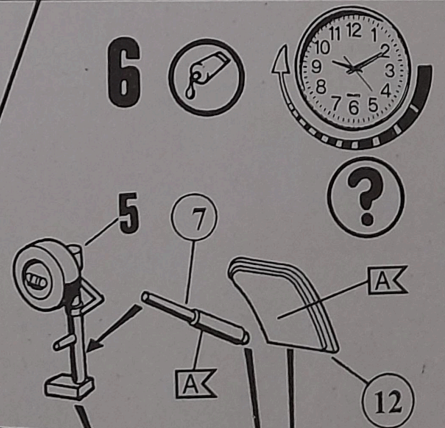
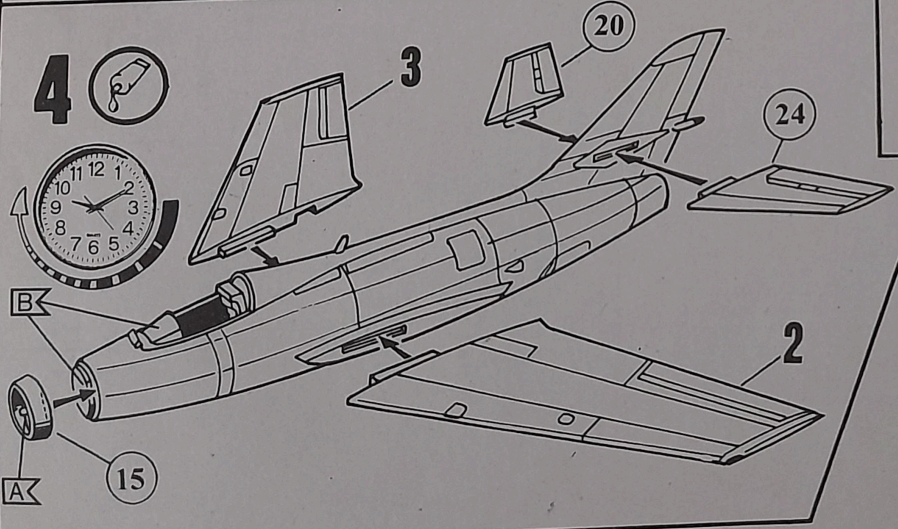
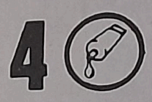
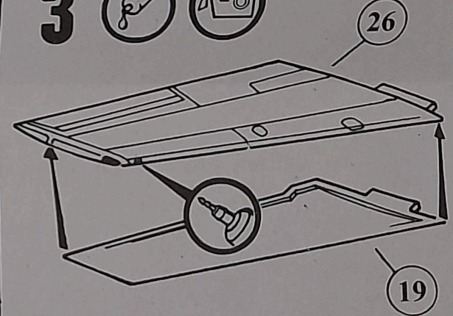
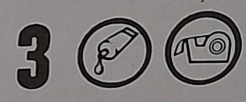
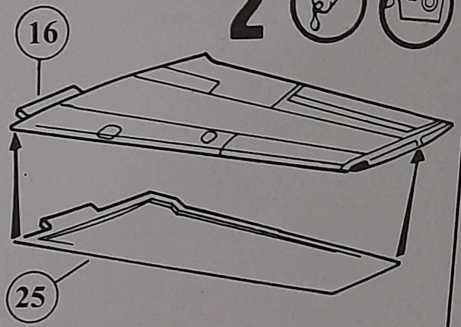
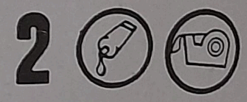
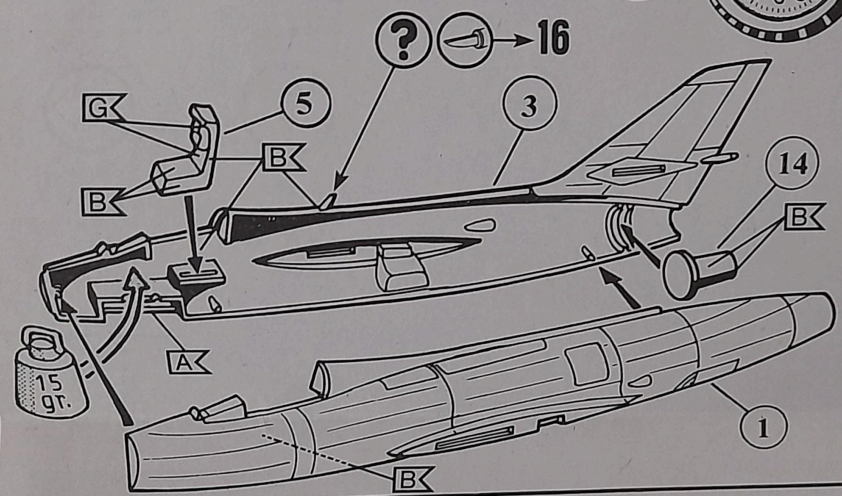
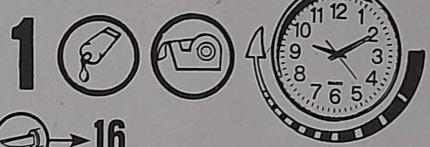
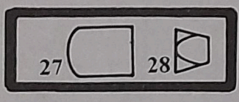
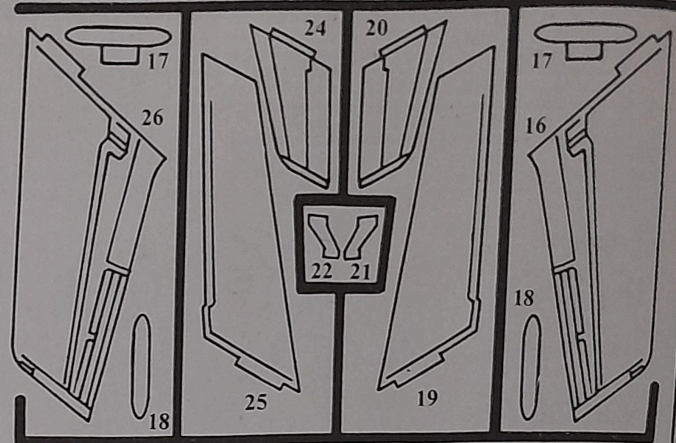
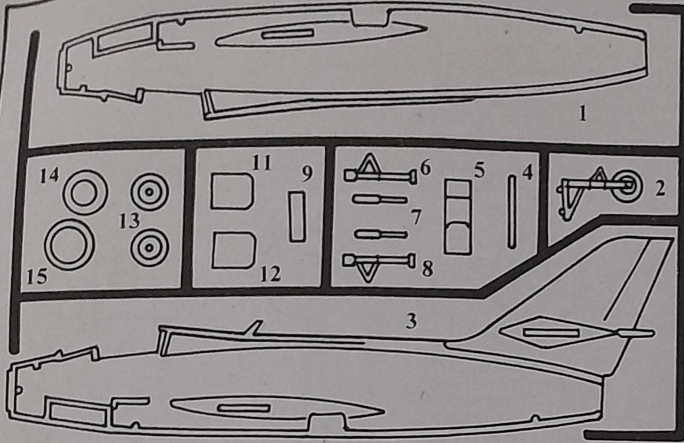

7

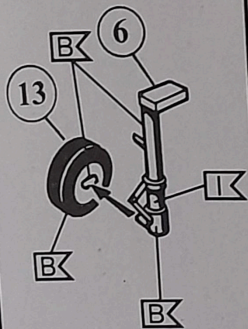

8

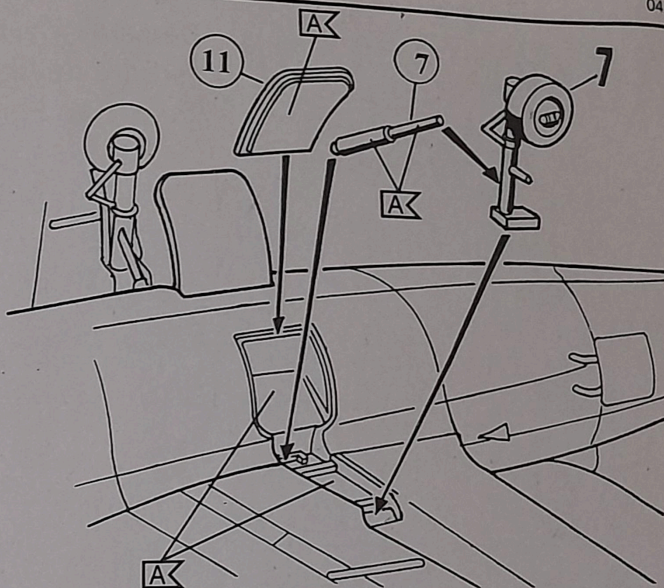
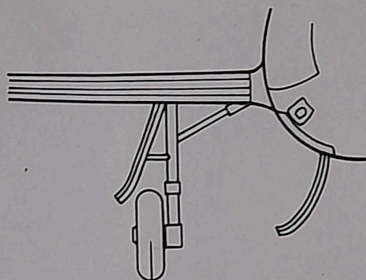

9

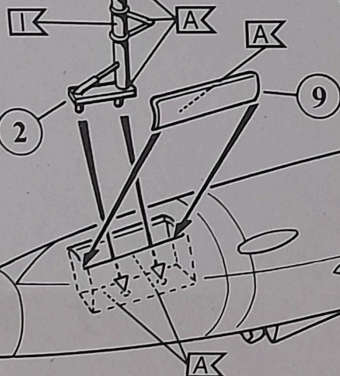

10

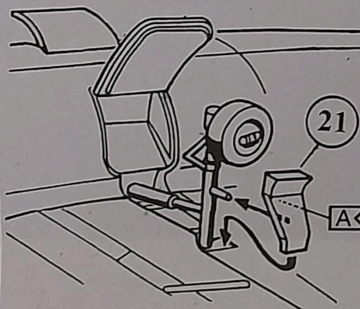

11

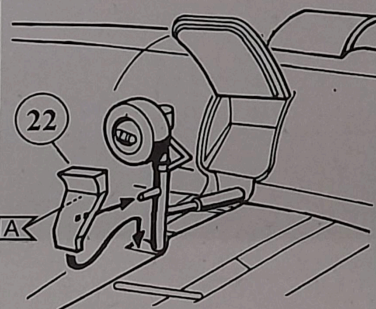

12

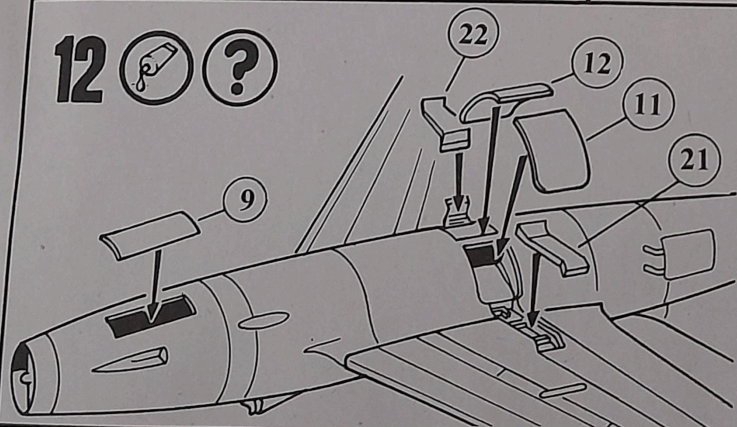

13

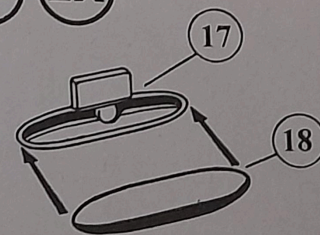

14

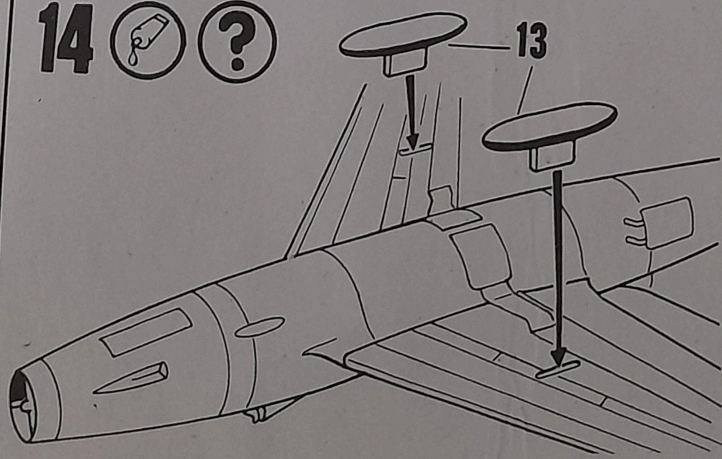

15

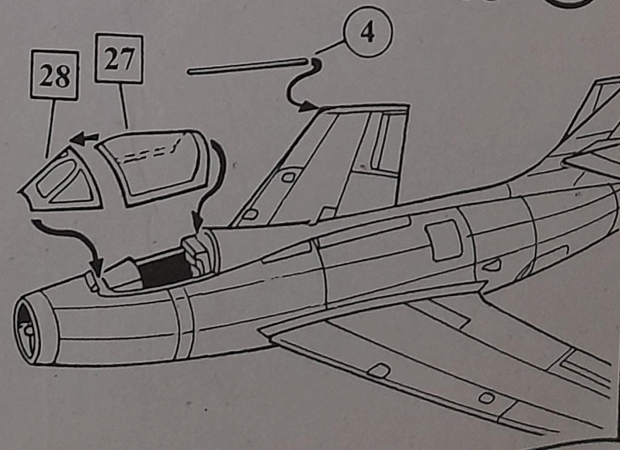

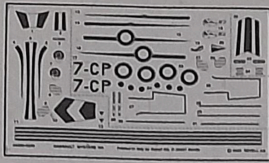

Dassault Mystère IVA, „Patrouille de France“ aerobatic team, Escadre de Chasse (EC)2, French Air Force, Dijon-Longvic air base, 1961.

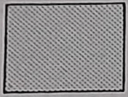
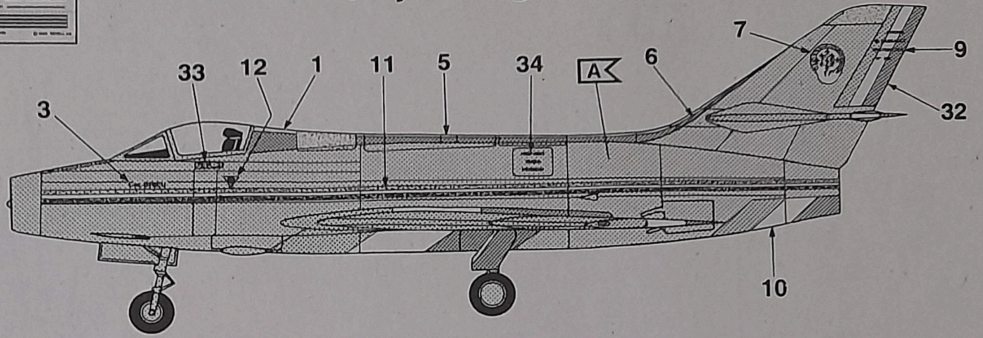

A

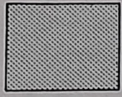

C

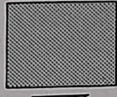

F

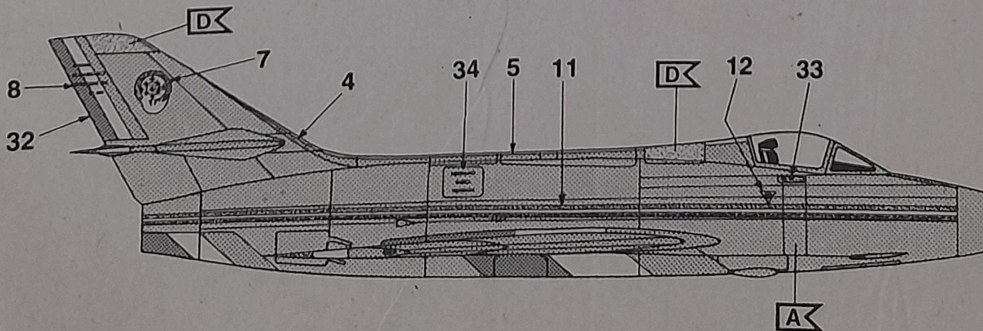
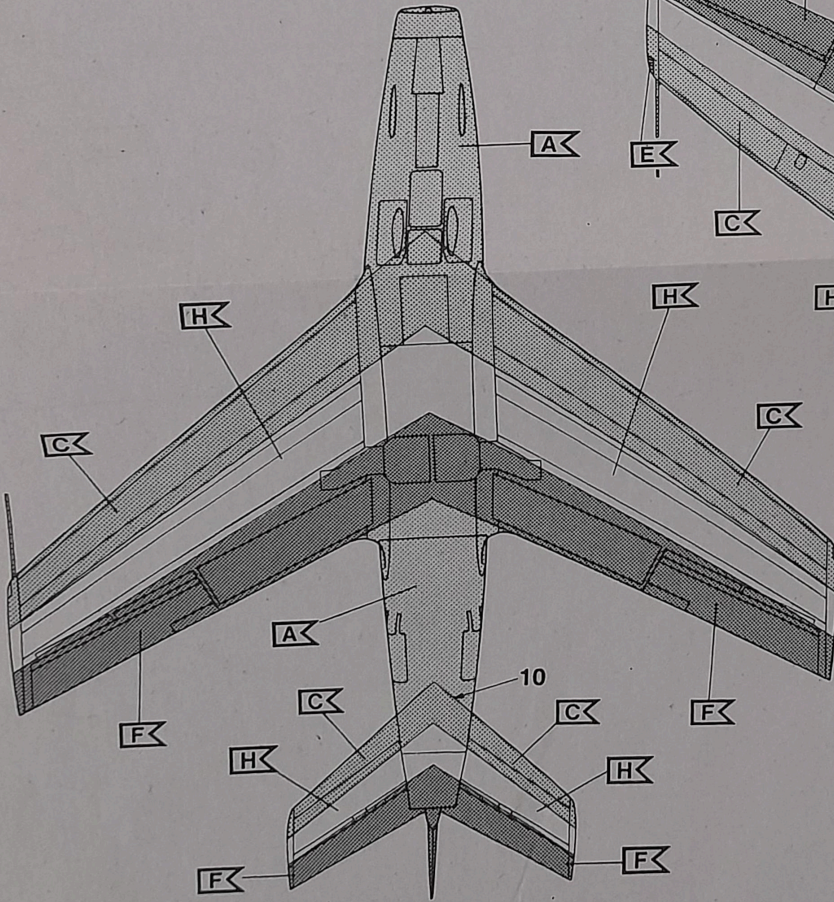
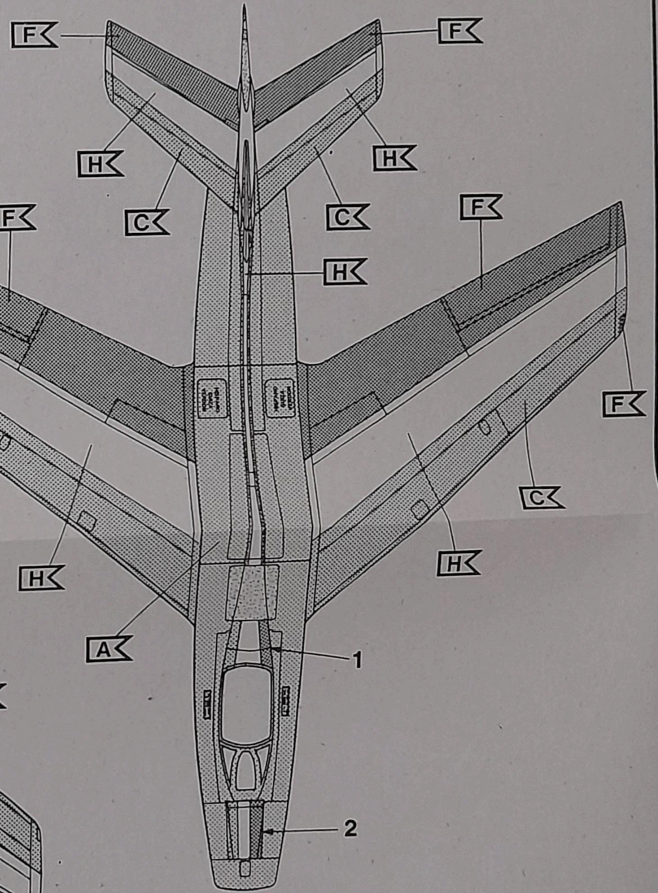

17

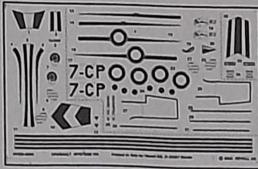

Dassault Mystère IVA,
Escadre de Chasse (EC) 1/7 „Languedoc“, French Air Force,
Nancy-Ochey air base, 1966.

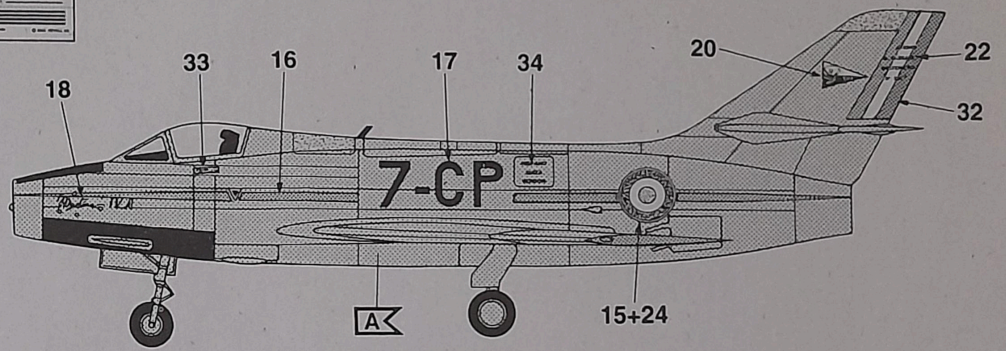

A

