

IROQUOIS: RNZAF Tactical Air Transport Helicopter - A True Story:

I was "last man charlie" in my Infantry Unit - C Company - of the Territorial arm 5WWCT (Taranaki), our enemy was closing fast, we were being overrun in every flank by a persistent band of marauding regulars whom preferred roasted Cut-Lunch Commando to army slops.

We'd called to be airlifted, it was to be our first flight in an Iroquois, but our Lt had forgotten the call sign, so we were looking hopelessly lost in a desert of sub-terranean wasteland (some call it, Waiouru) with a couple of mags of blanks and a few 1/2 eaten rat packs to share.

As the light began to fade, suddenly our ears were assaulted by the rolling throb of what could have been a ghostly herd of stampeding bulls, but in fact turned out to be a heartlifting detachment of RNZAF Iroquois. We stuffed our fists into our ears to prevent possible injury from the exuberant pummelling they were getting from the throb and stood there stunned, almost missing the Lt's bark of "Go, Go, Go!!!"

Firing from the hip as the Regulars breached our crumbling defence, we mass stacked our bodies into the Iroquois and with the doors wide open, catapulted out of the LZ in a flurry of dirt and leaves. With the skids brushing the tree tops, in an effort to break the pattern of fire the Regulars had laid down for us we spirited out of their clutches and disappeared into the black, riding the sky like knights in flying armour.

No. 3 Squadron - Iroquois - A Brief Profile:

The Iroquois are a Utility Flight Unit, attached to the RNZAF under No.3 Squadron based at Whenuapai and Wigram.

Supporting troop movements i.e. logistics support (internal or underslung loads); gun movements; aeromedical evacuation and specialist ops like rappelling take up a third of the Iroquois flying effort. The remaining two thirds are non-tactical comprising training and support of other agencies from the Police and the National Rescue Co-ordination Centre through to the Dept. of Conservation and N.Z. and U.S. research at the Antarctic.

No.3 Squadron's commitment to nationwide Search & Rescue efforts is substantial with aircraft & crew on 24 hour standby. The helicopter's skilled crews and superior winching capability have saved many lives both on land and at sea.

The Iroquois flexibility has also proved No.3 Squadron invaluable during disaster relief operations. Also displaying versatility during the summer as fire fighting platforms.

No.3 Squadron has a proud international reputation for professionalism serving closely with a multitude of other nations, both as a member of the Multinational Force and Observers Peacekeeping in the Sinai and in joint defence ops. No.3 Squadron has a strong commitment to the security of the nation, N.Z.'s neighbours in the Pacific and N.Z.'s allies worldwide.

UH-1H IROQUOIS

KC80

A Commemorative Plastic Model Kitset in 1/72nd scale, based upon the UH-1H Iroquois operated by the RNZAF No.3 Squadron, out of Whenuapai & Wigram. (this kit includes fully detailed instructions including the replication of the Iroquois camouflage paint scheme and Kiwi Roundels decals)



PARENTAL GUIDANCE REQUIRED FOR
MODELLERS UNDER TEN (10) YEARS OLD.

RNZAF - UH-1H IROQUOIS

ATTENTION: Useful Advice

Study the instructions carefully prior to assembly. Remove parts from the frame with a sharp knife or sprue cutters, cut away any excess plastic. Do not pull off parts. Assemble parts in numeric sequence. Use plastic cement only, and use it sparingly to avoid damaging the model. A, B, C Indicate on which frame the parts will be found. Paint small parts before detaching them from the frame, removing paint from parts that are to be cemented. Refer to additional instructions and painting advice as below. Exterior painting and decalling is overleaf.

TAMIYA

PAINTING INSTRUCTIONS:

These codes refer to Tamiya paint colours as indicated on instructions:
(You can use either Tamiya acrylic or enamel paints)

| | | |
|------------|----------------|-------------------|
| X2 White | XF1 Flat Black | XF49 Khaki |
| X11 Silver | XF9 Hull Red | XF53 Neutral Grey |
| X19 Smoke | XF15 Flesh | XF64 Red Brown |

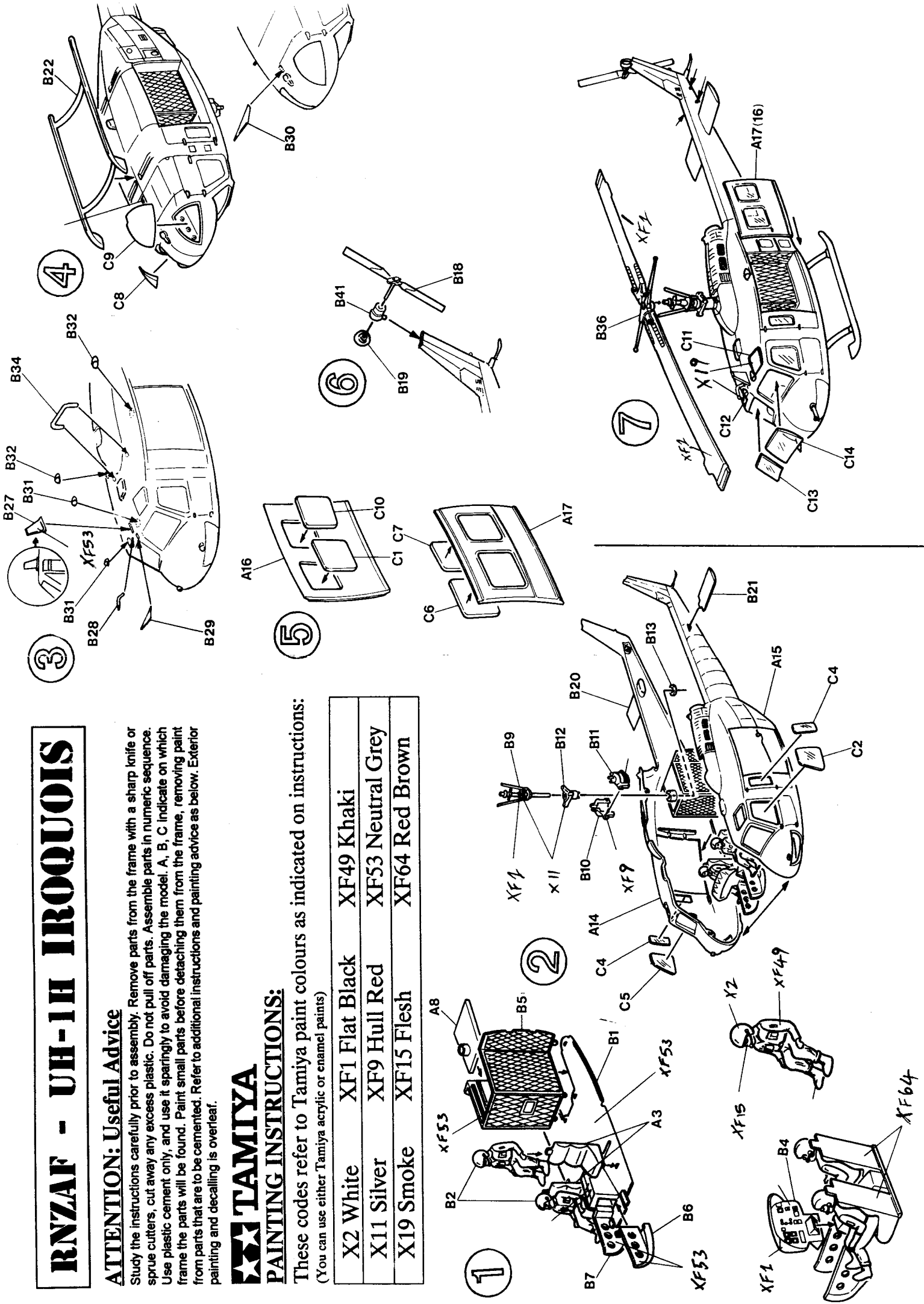

RNZAF UH-1H IROQUOIS

Painting & Decalling Instruction

These instructions are only valid once you have completed construction of your Iroquois.

Paint Colour Chart - for Tamiya Paints.



XF61: Dark Green



XF52/XF59: Mix a 50/50 Combination to give you Brown.



XF5: Light Green



Directions for Applying Decals:

Cut the required decals out of the sheet; dip them into a dish of clean water for about 1/2 a minute; position the decals on the kit, letting them slide form the paper. For a better adhesion, press with a clean rag.

Placing the Decals: Please read "Directions for Applying Decals"

The numbers on this chart correspond to the numbers on the Iroquois below.

Please place the KIWIs with their beaks and feet pointing forward towards the front of the Iroquois.



1. Blue circle, White Centre. Place this decal on the fuselage as shown. When the circle decal is in place and tacky, remove excess moisture with a dry tissue so roundel doesn't slide, then add the Red Kiwi (feet forward).



2. Small Roundel - Red Kiwi on Dark Blue Roundel. Place on tail as shown.



3. Medium Sized Roundel - Red Kiwi on Dark Blue Roundel. Place on Front door.

Painting Instructions:

The Iroquois Camouflage Paint Scheme as shown below is one of the schemes used by the RNZAF. For painting the other side, we suggest that you make up your own cam. scheme or simply paint the other side the same and join the schemes together.

N.B. Re Decals: we have included some extra decals for you to use on areas of your choice.

