



Flettner 282 B-2 1:72

Německý vrtulník - German helicopter from WW II

SCALE
PLASTIC KIT

92183

The F1 282 *Kolibri* was an improved version of the Flettner F1 265 announced in July 1940 which had the same intermeshing rotor configuration as the earlier helicopter. It had a Siemens-Halske Sh 14 radial engine of 150-160 hp mounted in the center of the fuselage, with a transmission mounted on the front of the engine from which a driveshaft ran to an upper gearbox which then split the power to a pair of opposite driveshafts to turn the rotors. The Sh 14 engine was a tried and tested design with a proven track record which only required servicing every 400 hours as opposed to the Focke Achgelis Fa 223 which needed maintenance every 25 hours. The F1 282's fuselage was constructed from steel tube covered with doped fabric, and it was fitted with a fixed undercarriage.

The German Navy was impressed with the *Kolibri* and wanted to evaluate it for submarine spotting duties, ordering an initial 15 examples to be followed by 30 production models. Flight testing of the first two prototypes was carried out through 1941, including repeated takeoffs and landings from a pad mounted on the German cruiser *Köln*.

The first two "A" series prototypes had enclosed cockpits; all subsequent examples had open cockpits and were designated "B" series.

Intended roles of F1 282 included ferrying items between ships and reconnaissance. However, as the war progressed, the Luftwaffe began considering converting the F1 282 for battlefield use. Until this time the craft had been flown by a single pilot, but now a position for an observer was added at the very rear of the craft, resulting in the B-2 version. The B-2 proved a useful artillery spotting aircraft and an observation unit was established in 1944 comprising three F1 282 and three Fa 223 helicopters.

In 1944 the German Air Ministry issued a contract to BMW to produce 1,000 units. However, the company's Munich plant was destroyed by Allied bombing raids after producing just 24 machines.

Towards the end of World War II most of the surviving F1 282s were stationed at Rangsdorf, in their role as artillery spotters, but gradually fell victim to Soviet fighters and anti-aircraft fire.

Použité prameny / References:

- Coates, Steve and Carbonel, Jean-Christophe. *Helicopters of the Third Reich*. Crowborough, UK: Classic Publications Ltd., 2002.
- Lung, Gerhard. *Flettner F1 282 (The Luftwaffe Profile Series, No 6)*. Atglen, PA: Schiffer Publishing, 1996.
- Nowarra, Heinz J. *German Helicopters, 1928-1945*. Atglen, PA: Schiffer Publishing, 1990.
- Smith, J. Richard and Kay, Anthony. *German Aircraft of the Second World War*. London: Putnam & Company Ltd., 1972 (3rd impression 1978).
- Witkowski, Ryszard. *Rotorcraft of the Third Reich*. Redbourn, UK: Mushroom Model Publications, 2007.

Průměr rotoru: 11,96 m

Délka / Length: 6,15 m

Výška / Height: 2,20 m

Nosná plocha / Wing area: 224,69 m²

Plošné zatížení / Wing loading:

Hmotnost prázdn. letounu / Empty weight: 760 kg

Vzletová hmotnost / Takeoff weight: 1000 kg

Pohonná jednotka / Powerplant: Bramo Sh 14A

Výkon pohonné jednotky: 160 hp

Maximální rychlost / Max. speed: 150 km/h

Dolet / Range: 170 km/h

Dostup / Service ceiling: 3300 m

Stoupavost: 8 m/s

RS
MODELS

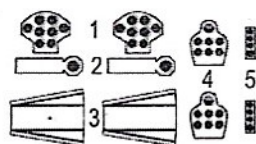
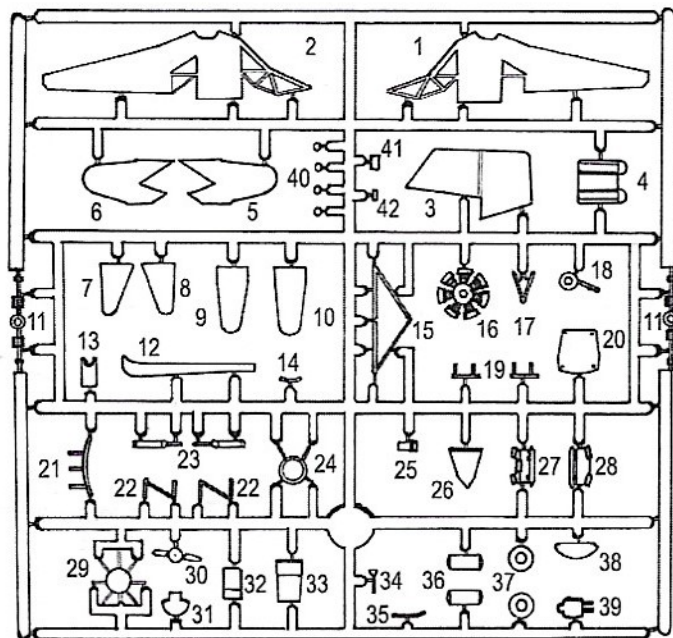

1

Sestavení motoru / Engine assembly

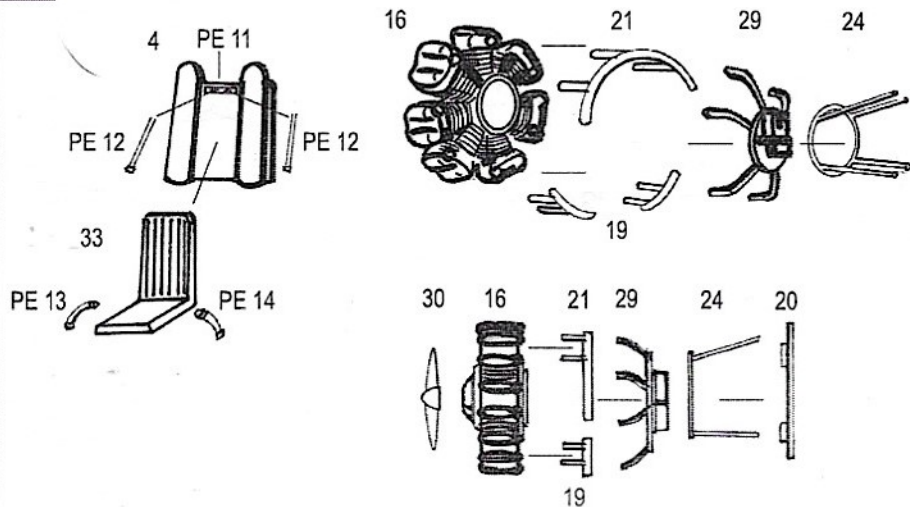

2

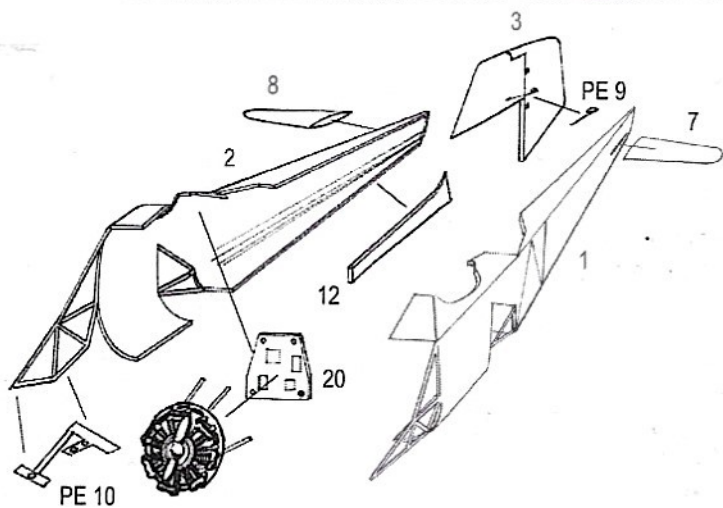

3

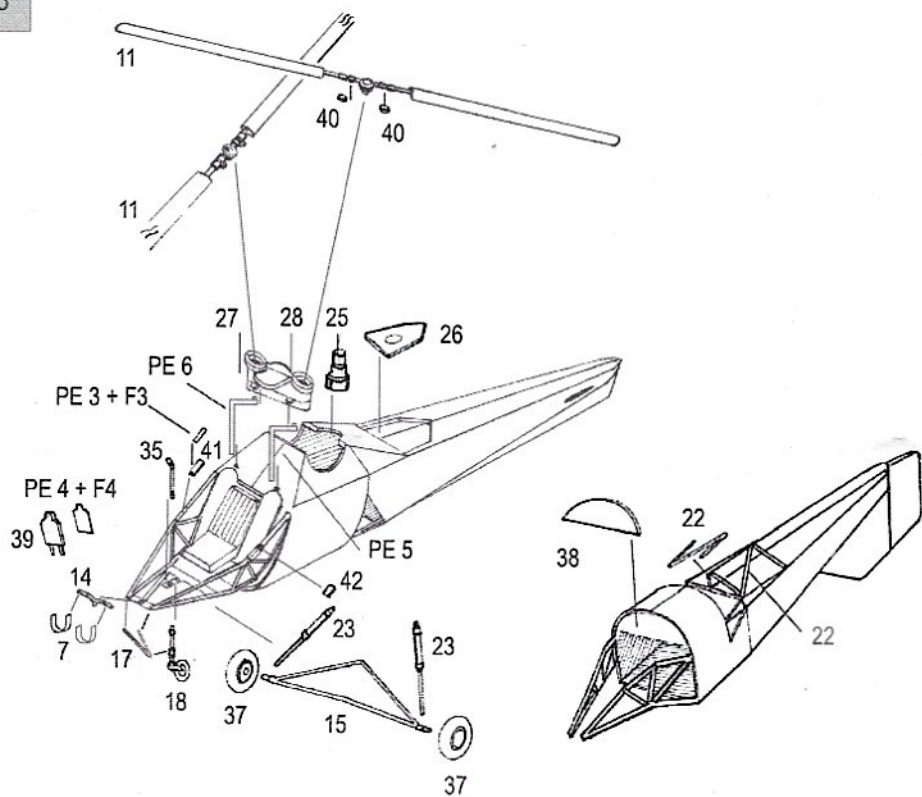

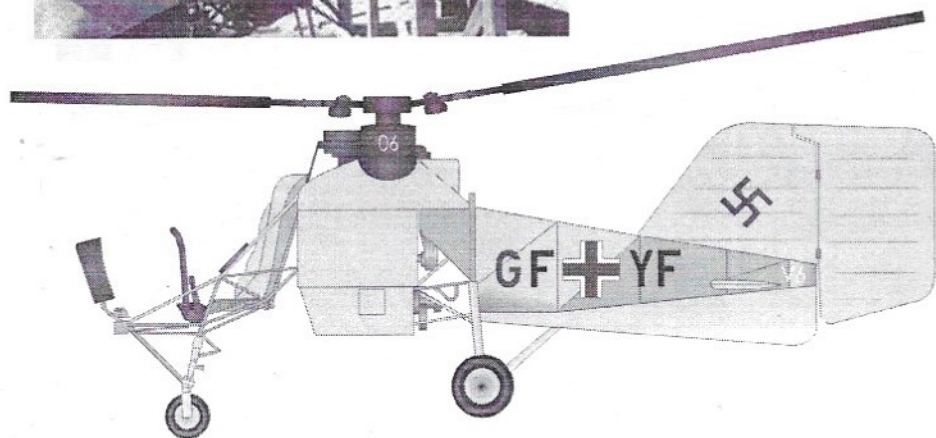
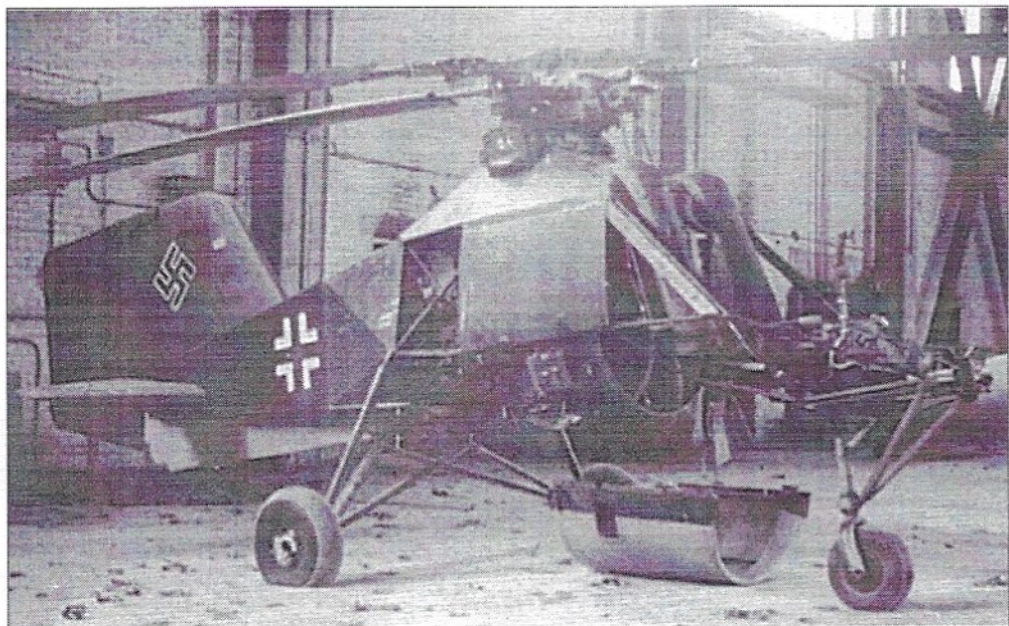

① Flettner 282 V6 Prototype, Cruiser "Köln", Baltic sea 1942, later Minelayer "Drache" 1943

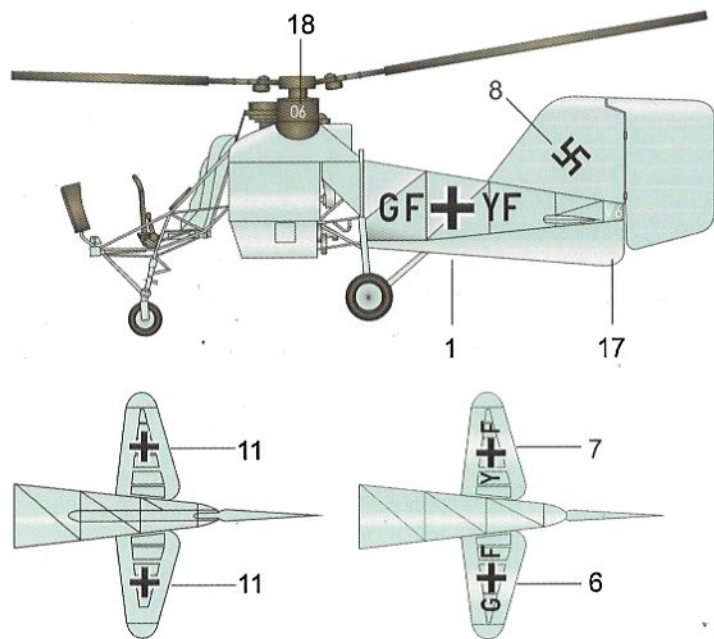

② Flettner 282 V18, 3./Bflgrp 196, Pillau, August 1944

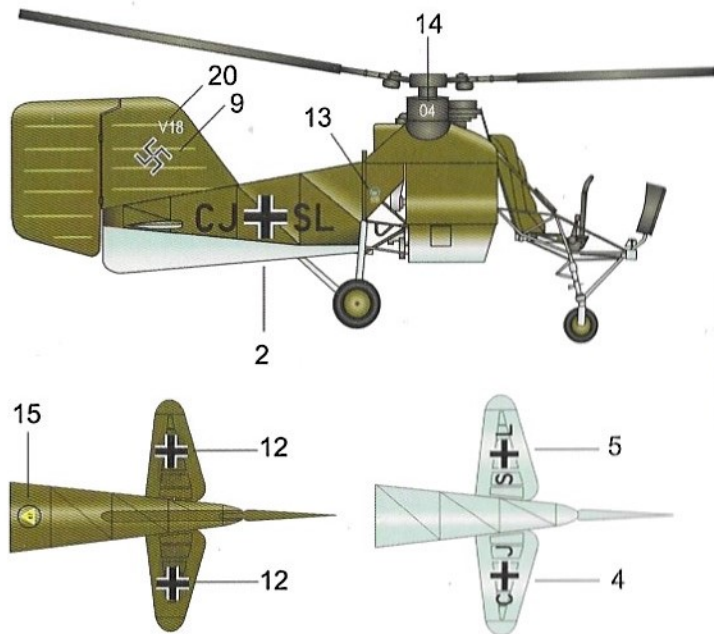

■ černá/black
 □ RLM 65
 ■ RLM 71
 ■ RLM 70

③ Flettner 282 V20, captured by the British, May 1945

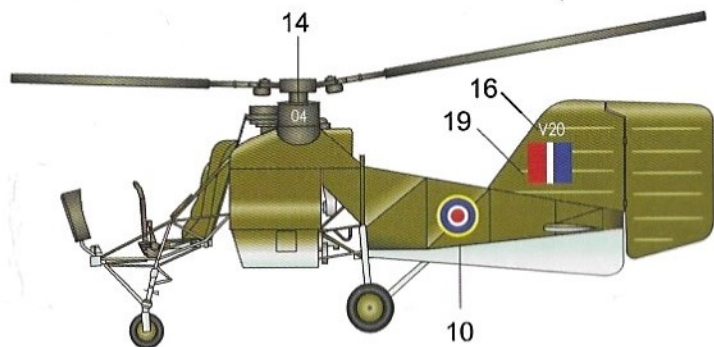

④ Flettner 282 V16, tested in Sukovskoje, USSR, 1947



Flettner FI 282 B-0

German Helicopter from WW II



RS
MODELS

1:72 SCALE
PLASTIC KIT

Machalpek 20.

92183