

STEP  
23

ASSEMBLY

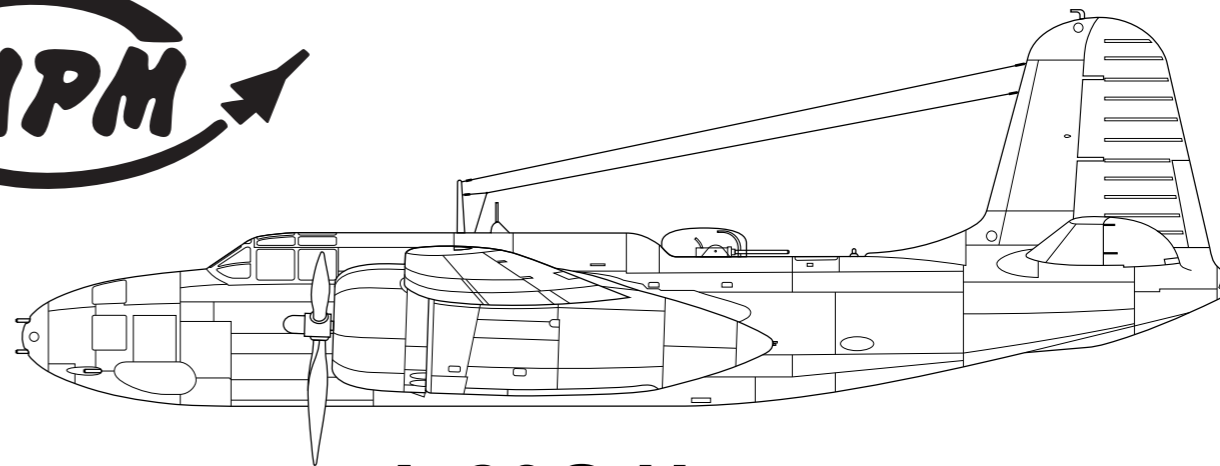
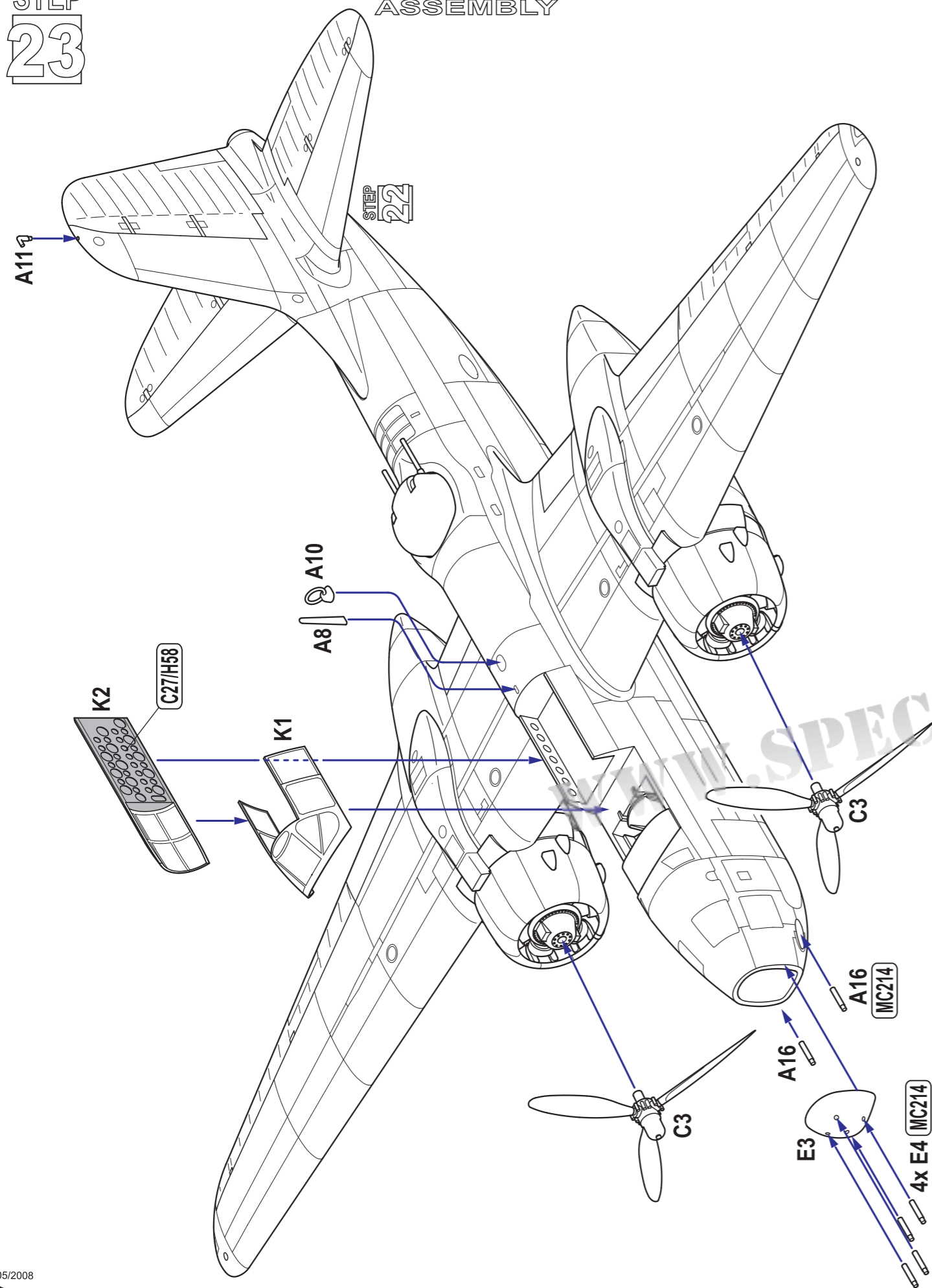

Kit No. 72551

## A-20G Havoc "D-Day Havocs"

1/72

**GZ** A-20G byla první opravdu masově vyráběnou verzí Havocu pro letectvo US Army. Oproti starším verzím byla redukována osádka na dva členy, před byla zaplechována a byla do ní soustředěna zesílená hlavňová výzbroj. První výrobní bloky A-20G-1 až G-15 dostaly výzbroj čtyř kanonů M1 a dvou kulometů ráže 12,7 mm a měly ještě původní provedení nekrytého střeliště. Protože došlo k nárůstu hmotnosti, a kanony M1 se při delších dávkách zasekávaly, nebylo s výkony prvních A-20G letectvo US Army spokojeno. Dvěšestpadesát kusů této verze dostal Sovětský svaz. U ostatních strojů byly kanony nahrazeny kulomety. Nejpozději od výrobního bloku A-20G-20 byly dodávány Havocy standardně s šesti kulomety ráže 12,7 mm v přídi a s do rozšířeného trupu instalovanou střeleckou věží Martin se dvěma kulomety ráže 12,7 mm. Další bloky byly shodné.

Na základě bitevní verze A-20G byla pro evropské bojiště vyráběna bombardovací verze A-20J. Ta se vrátila k prosklené přídi s pracovištěm navigátora-bombometčíka. Tyto letouny byly používány i jako vedoucí stroje pro formace A-20G.

Protože hmotnost Havoců neustále rostla, poslední verze vyráběné závodem v Santa Monica dostaly silnější variantu motorů R-2600-29. Kromě motorů se od A-20G a A-20J neodlišovaly. Bitevní verze s motory R-2600-29 dostala označení A-20H, bombardovací pak A-20K.

A-20G nasadilo letectvo US Army jak na evropském, tak pacifickém bojišti. V Pacifiku gunshipy A-20G zúčastnily bojů na N. Guineji, Filipínách, Palauských ostrovech, Tchaj-wanu a Okinavě. V Evropě se americké A-20 posledních verzí dostaly do bojů na Sicílii a Itálii, ale zejména byly masově nasazeny nad západní Evropou ze základen ve Velké Británii. Mimo letectvo US Army používalo Havocy verze A-20J a K RAF. To je nasadilo pod označením Boston Mk.IV (A-20J) a Boston Mk.V (A-20K) hlavně v Itálii. S Havocy také operovala 342. peruť Svobodných Francouzů Lorraine bojující v rámci RAF. Sovětský svaz dostal Havocy A-20G jak prvních tak i pozdějších výrobních bloků a intenzivně je nasadil v rámci sovětského letectva i leteckých jednotek sovětského námořnictva. RAAF převzalo dvacet devět strojů A-20G. A-20G doplnily starší stroje Havoc/Boston u 22. sq. RAAF. Při těžkém japonském náletu 23. 11. 1944 byla část strojů zničena. Zbýlé A-20G byly vráceny US Army a 22. sq. RAAF byla přezbrojena na Beaufightery. Brazílie dostala v rámci zákona Lend-Lease třicet jedna kusů A-20K, které sloužily až do poloviny padesátých let.

Rozpětí: 18,69 m, délka: 14,81 m, max. rychlost: 490 km/h u země/ 510 ve výšce 3050 m, dostup: 7230 m, dolet 1610 km s 900 kg pum.

**GB** A-20G was the Havoc's first mass produced version for the USAAF. Compared to earlier versions the crew was reduced to only two members and the solid nose contained boosted armament. The early production blocks from A-20G-1 to G-15 were equipped with four 20 mm M1 cannons and two 12.7mm machine guns and early enclosed dorsal gunner's station with flexible mounted machine guns. Thanks to the weight increase and the M1 cannons jamming the USAAF was not satisfied with the early aircraft performances. 250 aircraft of the early batch were eventually given to the USSR under Lend-Lease. The rest of the already produced aircraft armament changed from cannon to machine guns. From A-20G-20 the aircraft were delivered with six nose mounted 12.7 mm machine guns and electrically driven Martin turret with two 12.7 mm machine guns mounted into widened dorsal position. The subsequent production blocks were the same.

Bomber version A-20J intended for European Theatre was based on A-20G. This version received the glazed nose section for navigator-bombardier. These aircraft were also used as A-20G formation leaders.

Since the Havocs' weight increased constantly the last produced versions in Santa Monica received more powerful R-2600-29 engines. Engines were the only difference from A-20G. The ground attack version with R-2600-29 engines was designated A-20H and bomber version A-20K.

USAAF deployed A-20Gs to both European and Pacific theaters. Gunships A-20G in Pacific participated in fights over New Guinea, Philippines, Palau Islands, Thai-Wan and Okinawa. In Europe, the late versions of US Havocs participated in fights over Sicily and Italy but were mainly deployed over Western Europe from their bases in Great Britain. Except USAAF were A-20J and K Havocs used by RAF that deployed them under its own designation Boston Mk.IV (A-20J) and Boston Mk.V (A-20K) mainly over Italy. Havocs were also operated by Free French 342nd Squadron Lorraine under RAF. USSR received A-20Gs of early as so the later production blocks and assigned them to both air force units and navy units. RAAF received twenty nine A-20Gs. The Gs completed the early version of Havocs / Bostons in RAAF 22 Squadron. Several machines were destroyed during heavy Japanese air raid on November 23, 1944. The remaining A-20Gs were returned to USAAF and RAAF 22 Squadron was re-equipped with Beaufighters. Under Lend-Lease, 31 A-20K were delivered to Brazil where served up to the 1950s.

Technical Data:

Wing span: 18.69m, Length: 14.81m, Max. Speed: 490kmh at sea level / 510kmh at 3050m, Service Ceiling: 7230m, Range: 1610km with 900kg bomb load

MPM 72551 - A-20G Havoc

05/2008

8

KIT PARTS

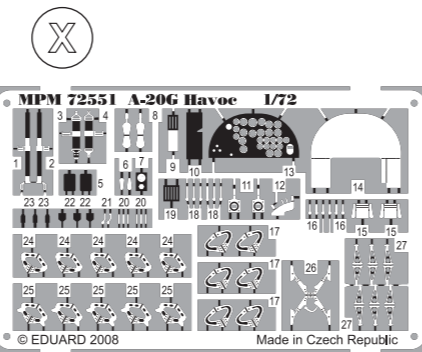
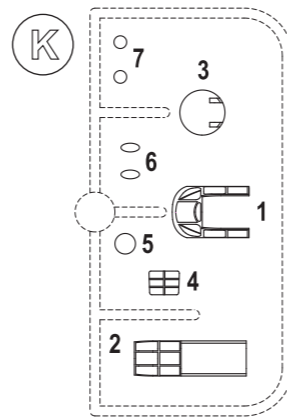
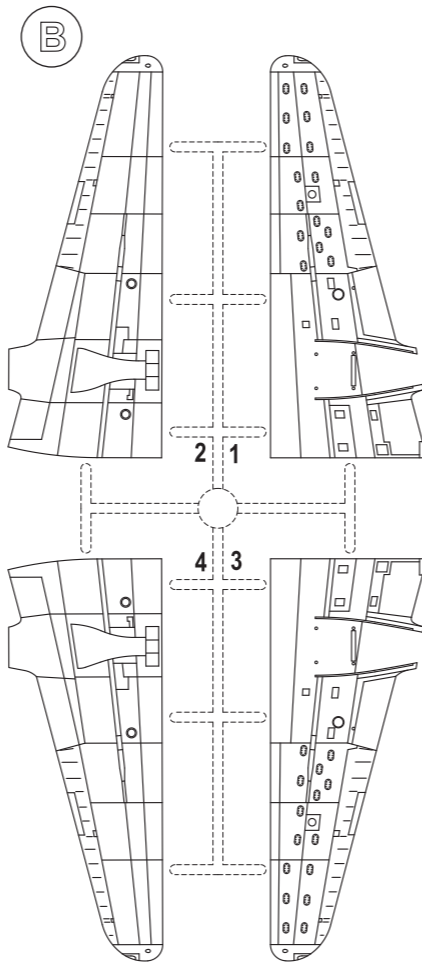
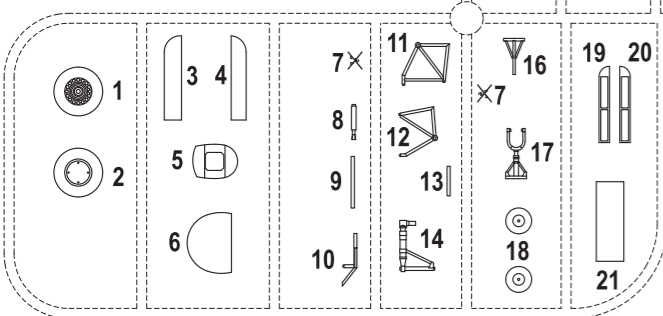
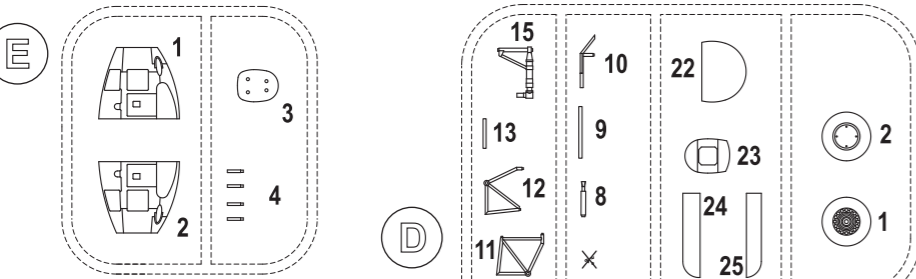
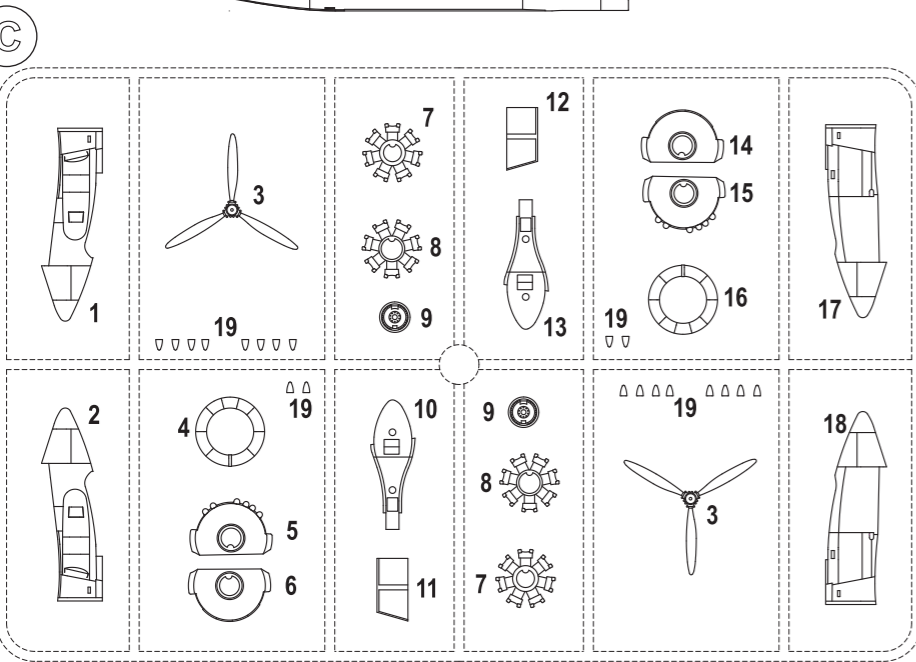
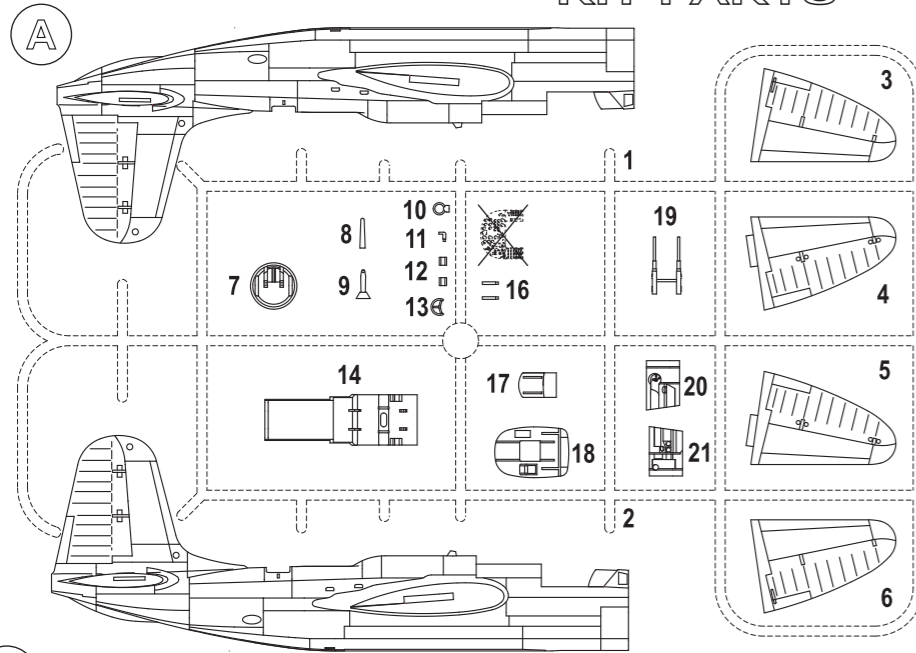

SYMBOLS



MPM 72551 - A-20G Havoc

STEP 21

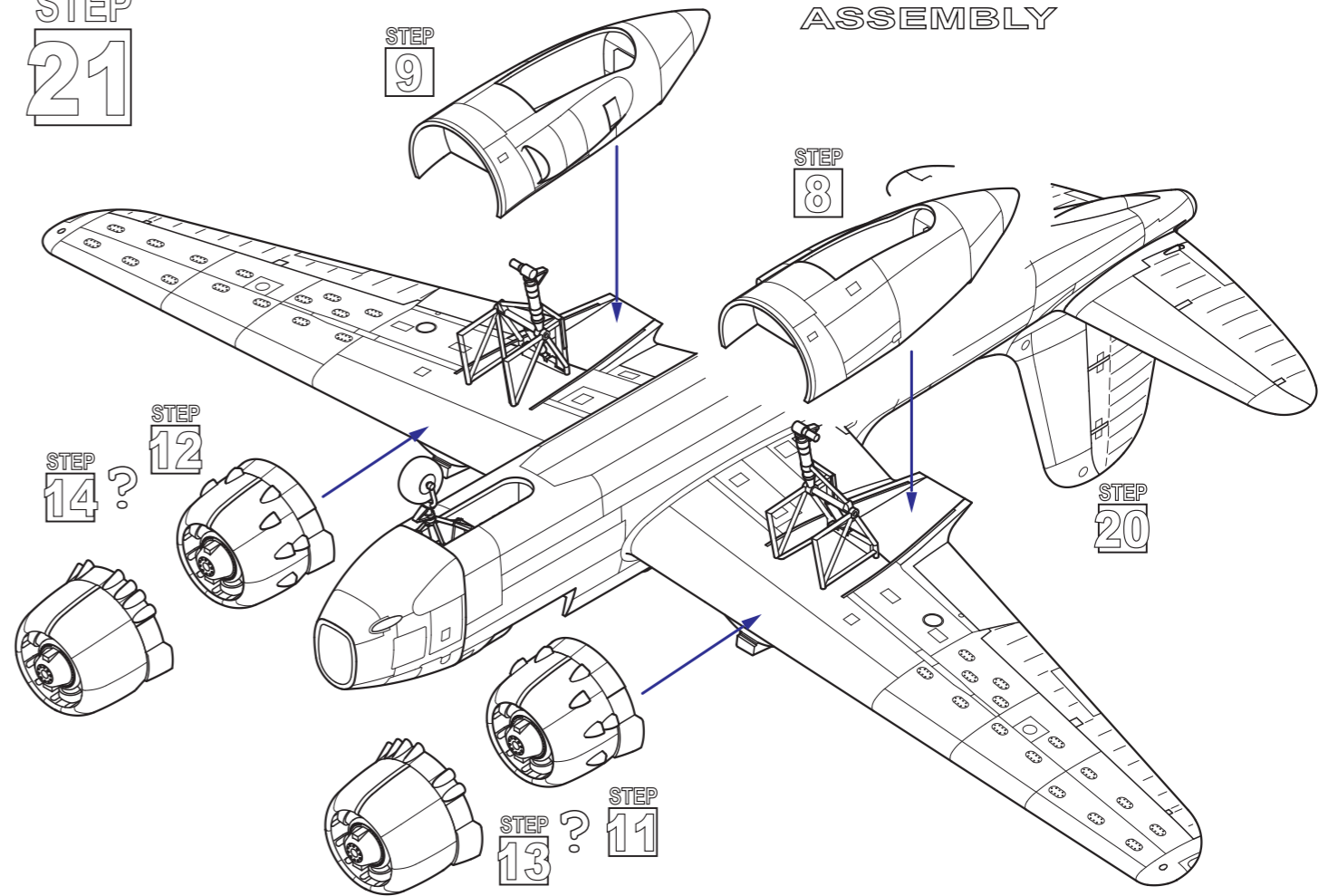

STEP 22

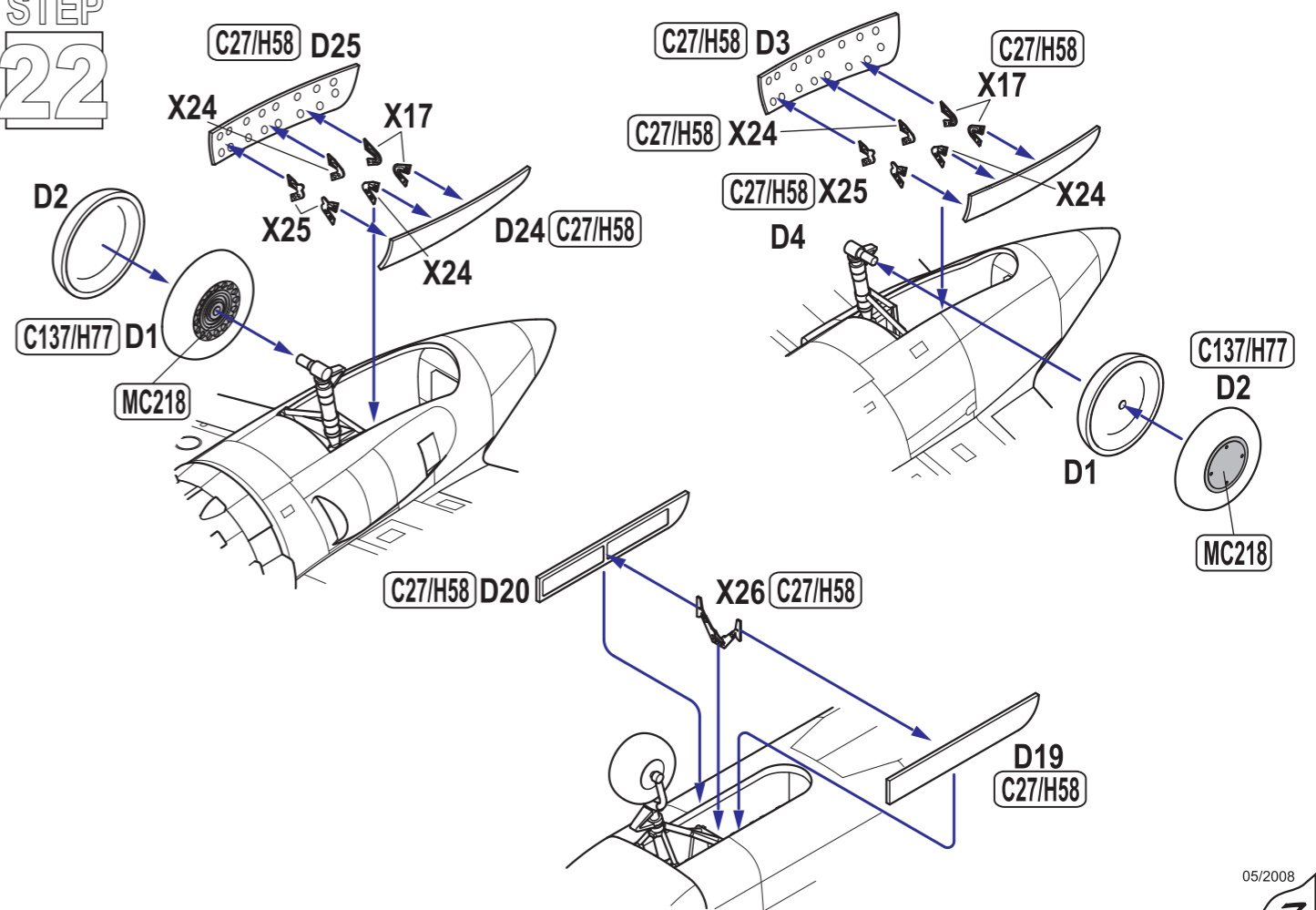

MPM 72551 - A-20G Havoc



ASSEMBLY

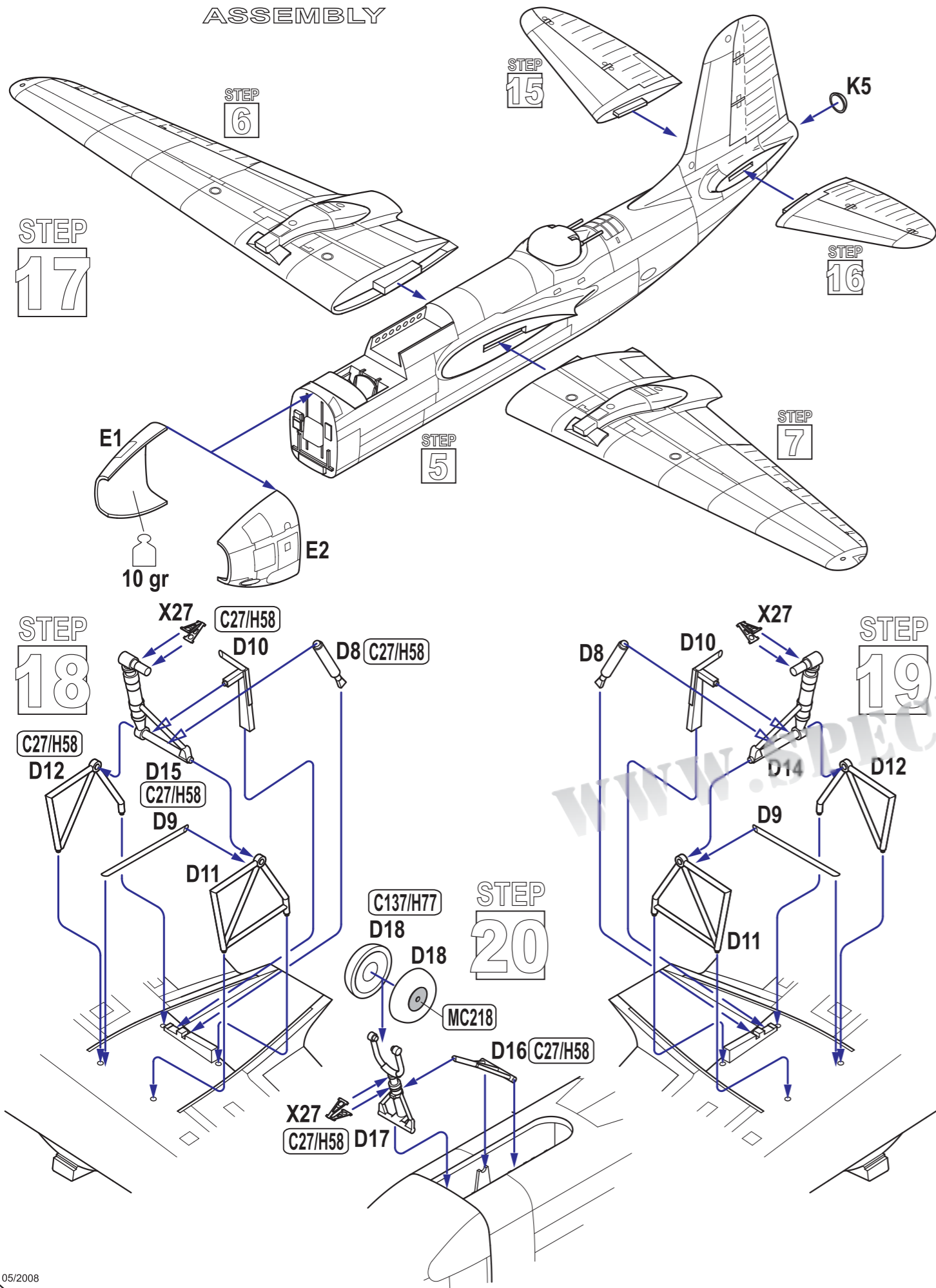

STEP 1

STEP 2

STEP 5

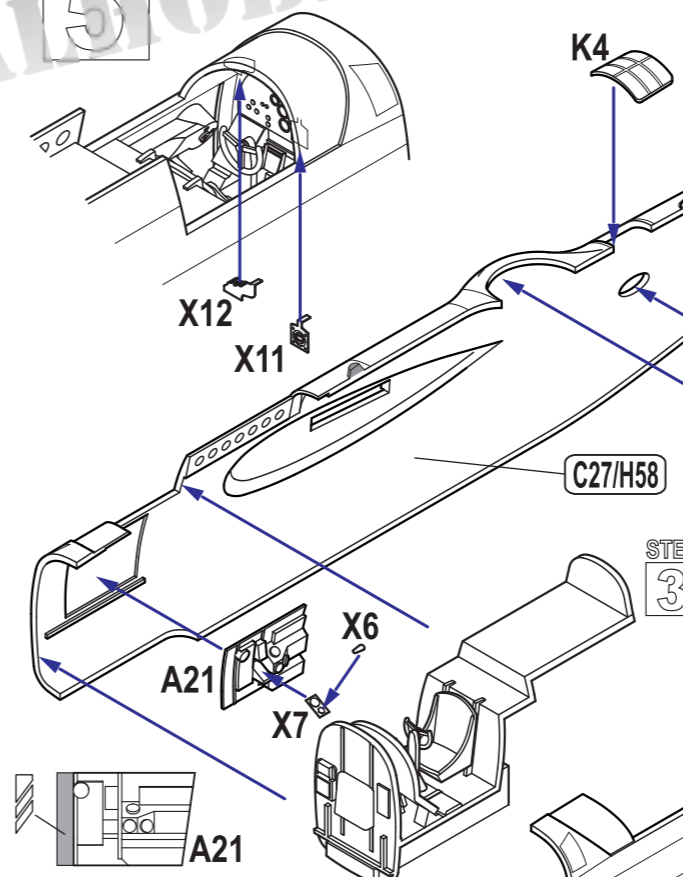
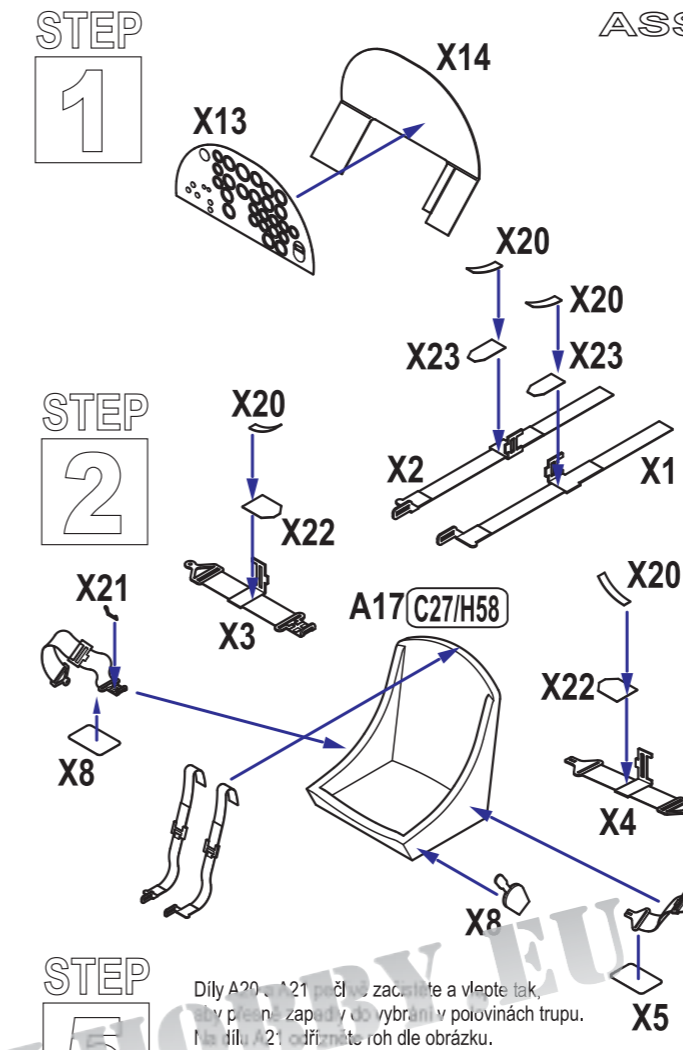

Carefully clean parts A20 and A21 so they fit in recesses in the fuselage halves.  
Cut the corner of part A21 according to the drawing.

ASSEMBLY

STEP 3

STEP 1

STEP 4

STEP 3

STEP 4

3

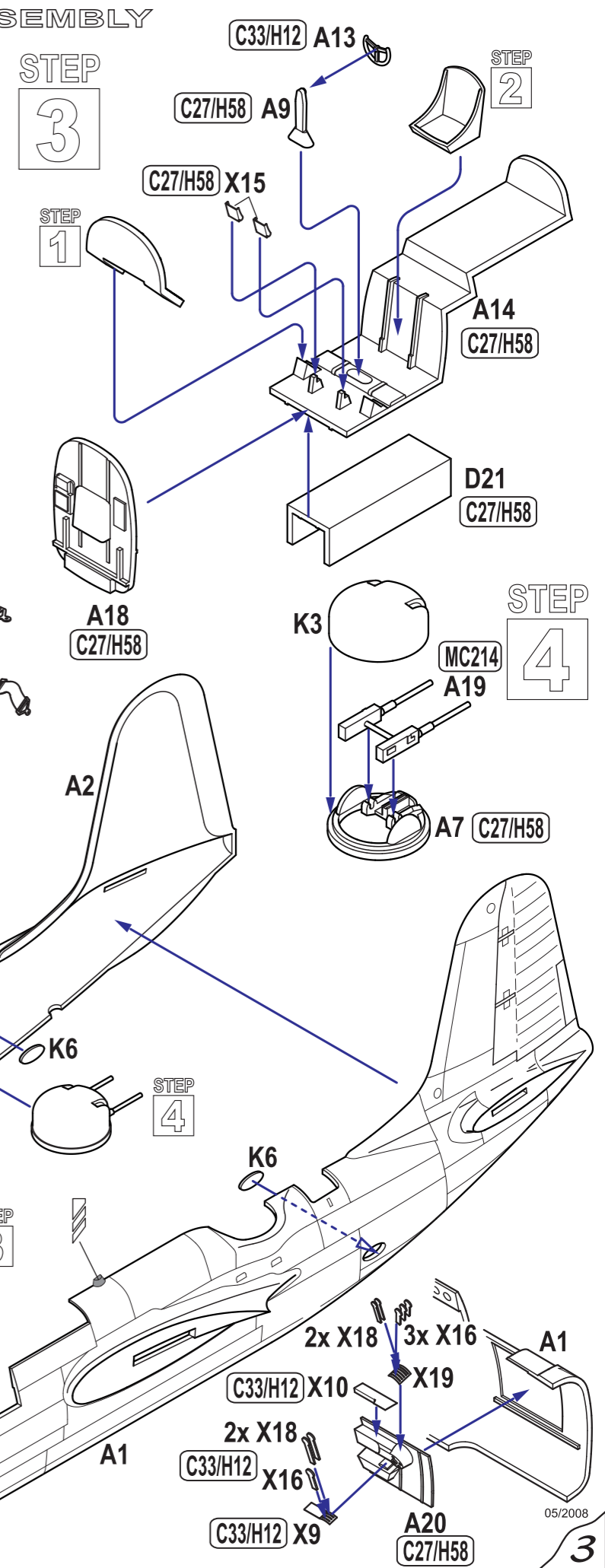

ASSEMBLY

STEP 6

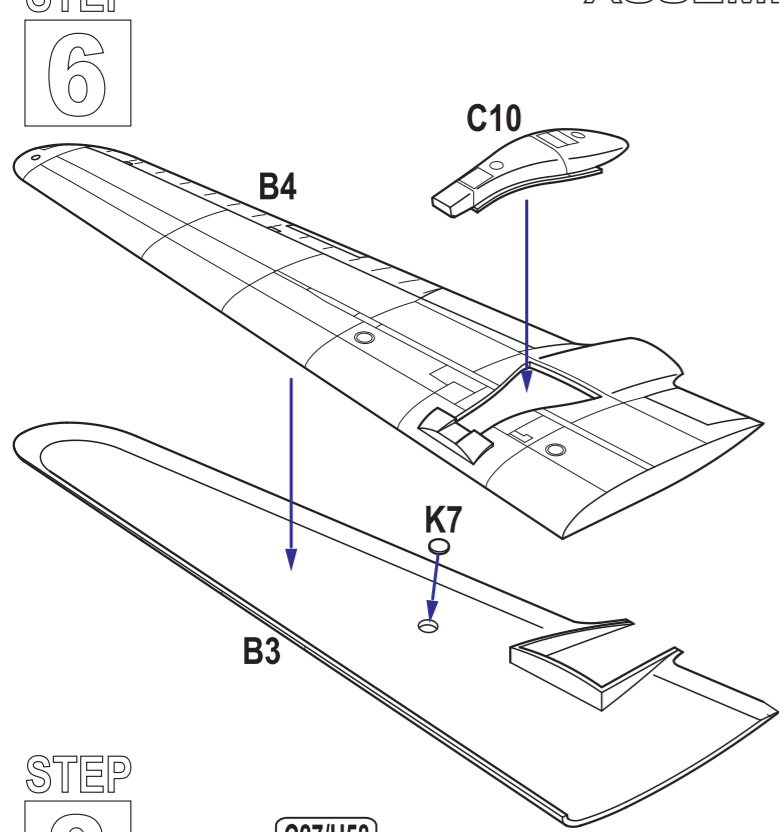

STEP 7

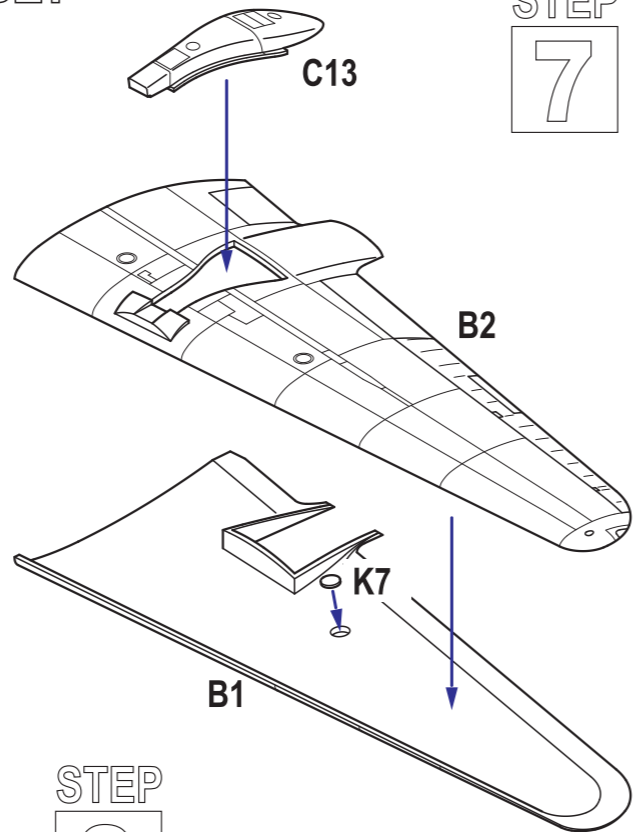

STEP 8

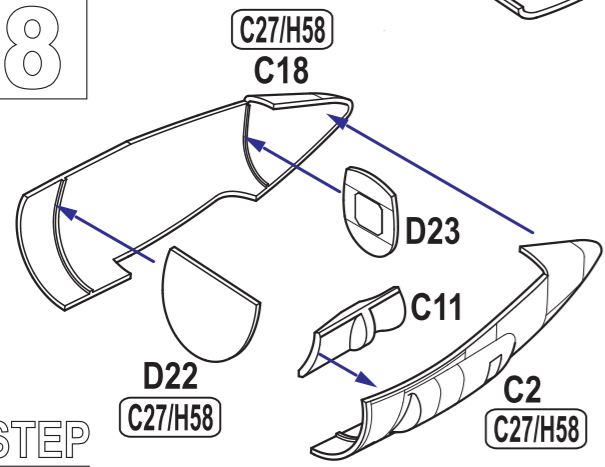

STEP 9

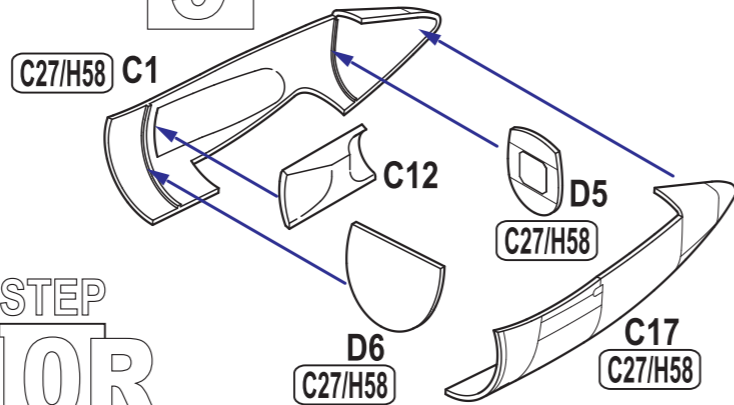

STEP 10L only CAMO A, C

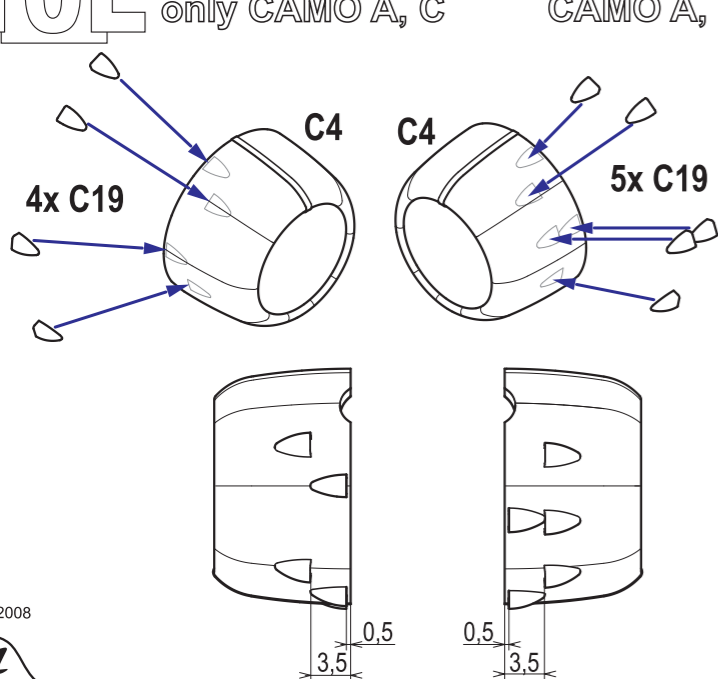

STEP 10R only CAMO A, C

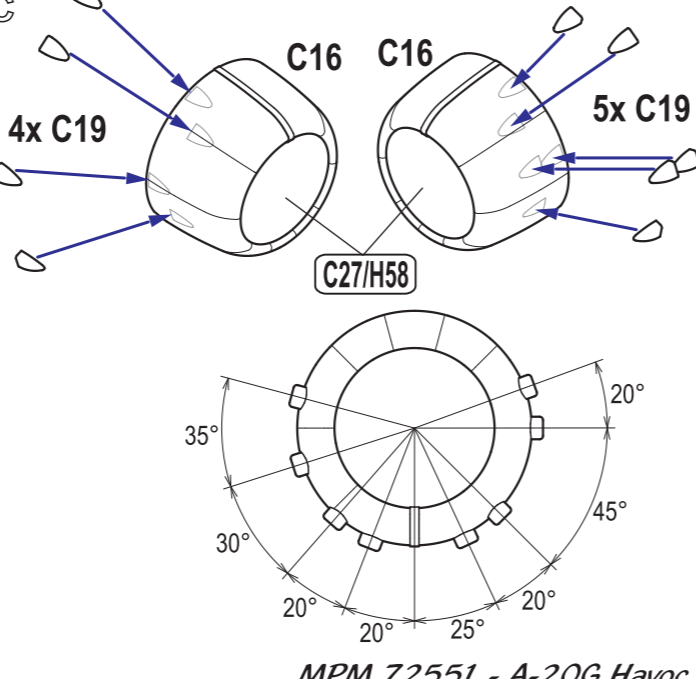

ASSEMBLY

STEP 11 only CAMO A, C

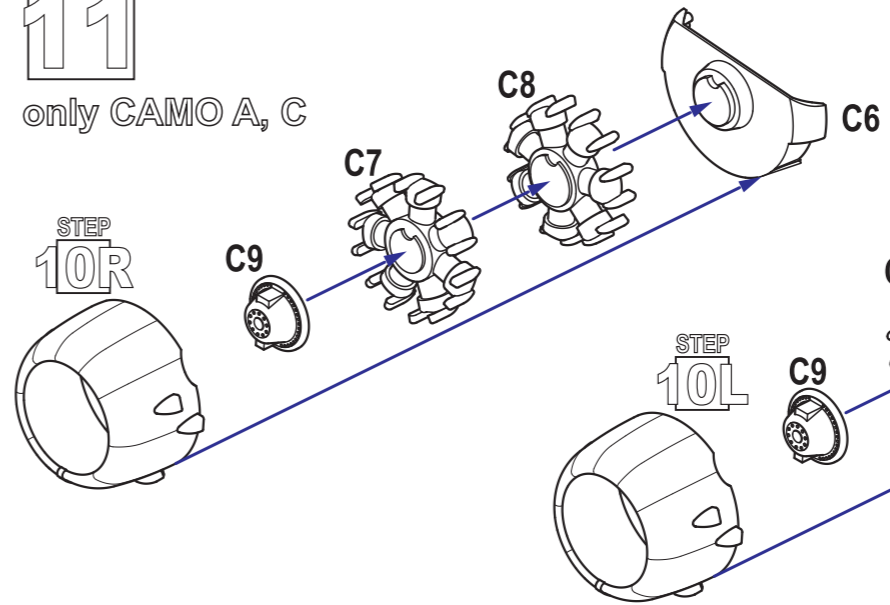

STEP 10R

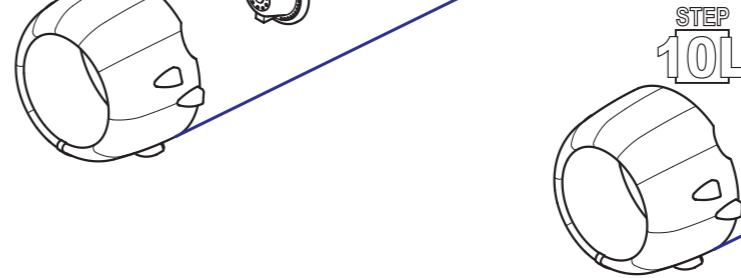

STEP 13 only CAMO B, D

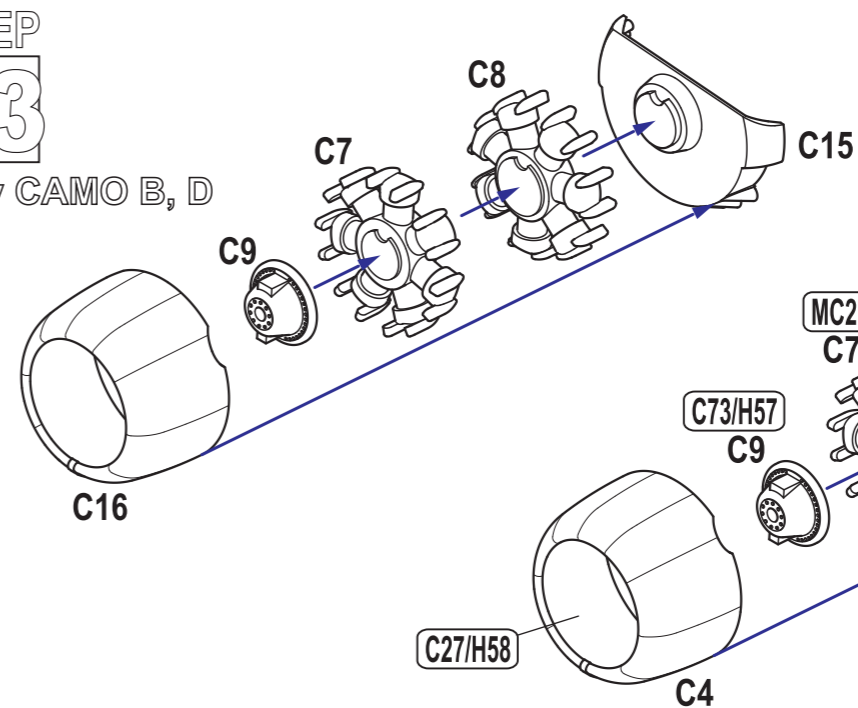

STEP 12 only CAMO A, C

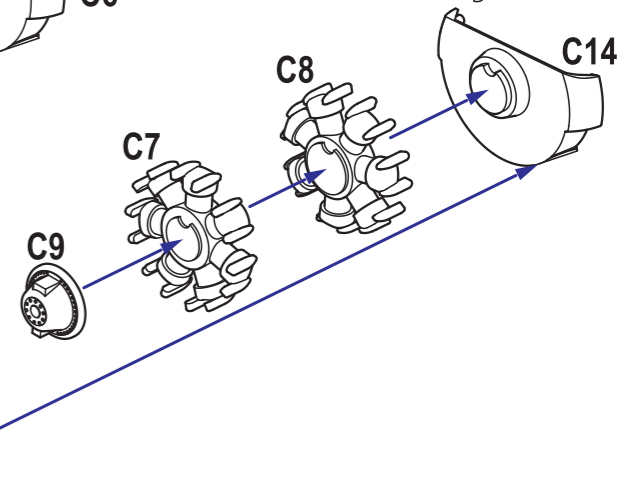

STEP 14 only CAMO B, D

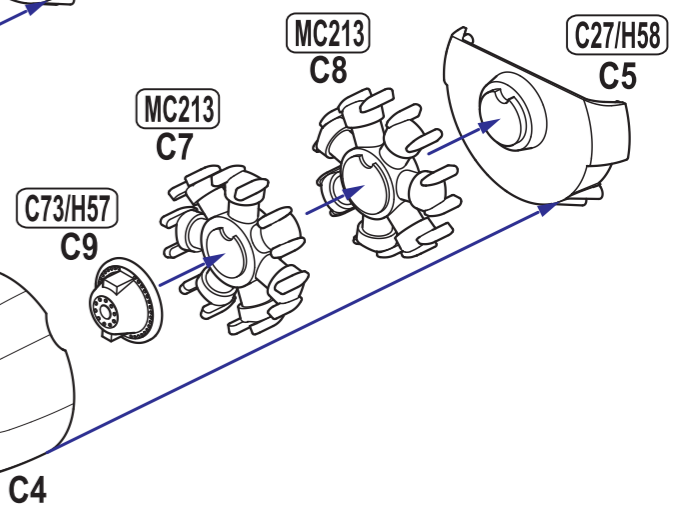

STEP 15

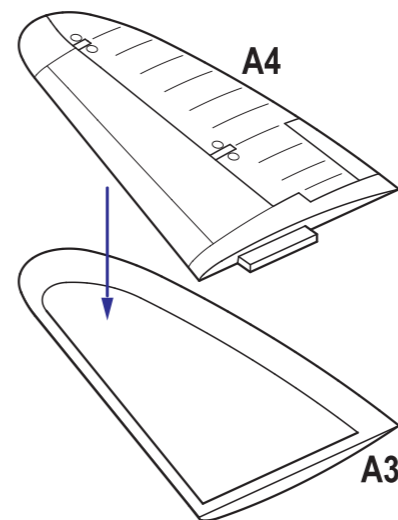

STEP 16

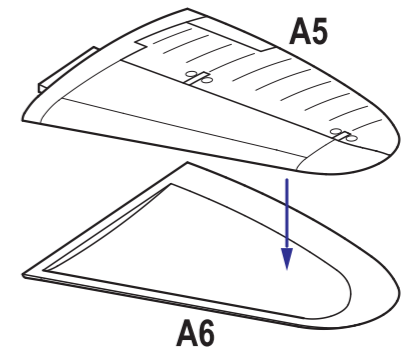



CAM. A

A-20G-35 Havoc, ser. 43-10195, 8U-U, „Queen Julia“, 646. BS, 410. BG, Francie, druhá polovina roku 1944. Invazní pruhy na horních plochách již byly přetřeny. Kamufláž tohoto stroje byla olétaná.

A-20G-35 Havoc, s/n 43-10195, 8U-U, „Queen Julia“, 646th BS, 410th BG, France, second half of 1944. Upper surfaces invasion stripes were already over painted. The camouflage of this aircraft was weathered.

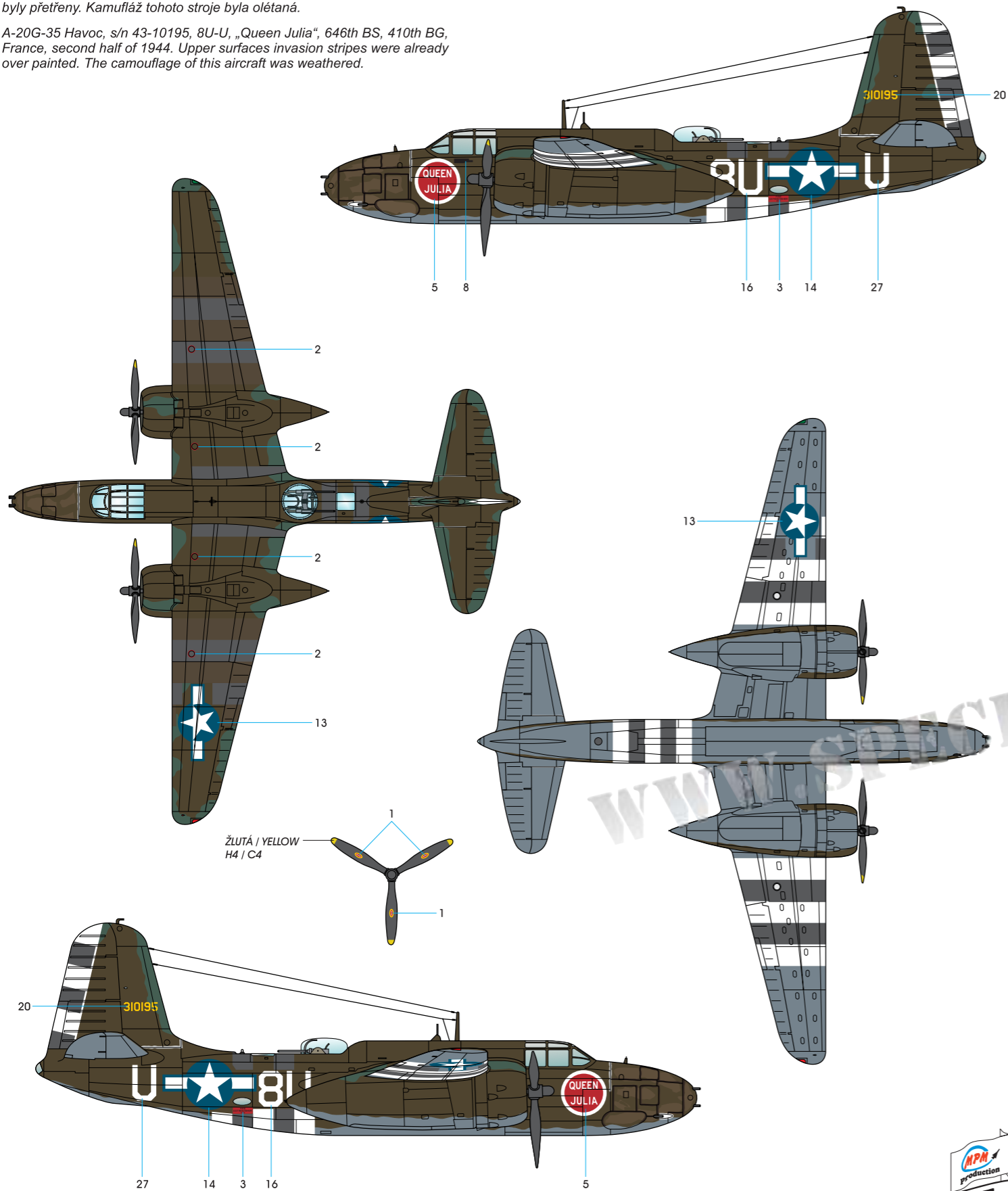

- |  |   |  |  |                                       |
|--|---|--|--|---------------------------------------|
| <b>A</b>                                 | <b>B</b>  | <b>C</b>                                       | <b>D</b>                               | <b>E</b>                              |
| OLIVOVÁ 41<br>OLIVE DRAB 41<br>H52 / C12 | STŘEDNÍ ZELENÁ 42<br>MEDIUM GREEN 42<br>H302 / C302 | SVĚTLE ŠEDÁ 43<br>NEUTRAL GREY 43<br>H53 / C13 | MATNÁ ČERNÁ<br>FLAT BLACK<br>H12 / C33 | MATNÁ BÍLÁ<br>FLAT WHITE<br>H11 / C62 |

72551 A-20G Havoc



CAM. B

A-20G-25 Havoc, ser. 43-9224, 5H-E, „La France Libre“, 668. BS, 416. BG, Francie, 1944. Tento letoun, původně pojmenovaný „Miss Laid“, byl prvním Havocem, který odlétal 100 misí nad okupovanou Francií. Invazní pruhy na horních plochách již byly přetřeny. Kamufláž tohoto stroje byla olétaná.

A-20G-25 Havoc, s/n 43-9224, 5H-E, „La France Libre“, 668th BS, 416th BG, France, 1944. This aircraft that was originally named „Miss Laid“ was the first Havoc to complete 100 missions over occupied France. Upper surfaces invasion stripes were already over painted. The camouflage of this aircraft was weathered.

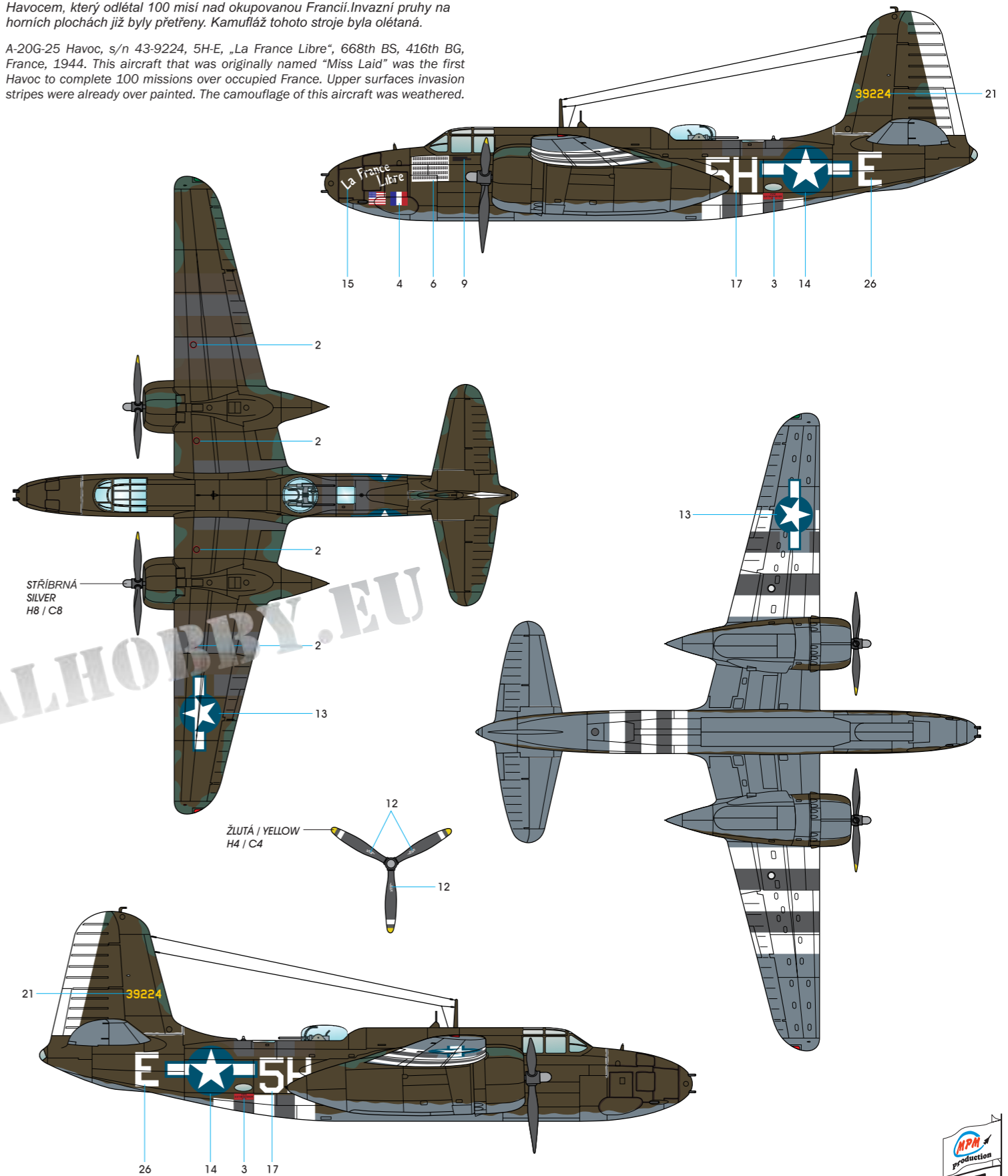

- |  |   |  |  |                                       |
|--|---|--|--|---------------------------------------|
| <b>A</b>                                 | <b>B</b>  | <b>C</b>                                       | <b>D</b>                               | <b>E</b>                              |
| OLIVOVÁ 41<br>OLIVE DRAB 41<br>H52 / C12 | STŘEDNÍ ZELENÁ 42<br>MEDIUM GREEN 42<br>H302 / C302 | SVĚTLE ŠEDÁ 43<br>NEUTRAL GREY 43<br>H53 / C13 | MATNÁ ČERNÁ<br>FLAT BLACK<br>H12 / C33 | MATNÁ BÍLÁ<br>FLAT WHITE<br>H11 / C62 |

72539 A-20G Havoc



**CAM. C**

A-20G-35 Havoc, ser. 43-10208, 5D-S, „Es For Sugar“, 644. BS, 410. BG, Francie, druhá polovina roku 1944. Invazní pruhy na horních plochách již byly přetřeny, aby se snížila viditelnost shora. Kamufláž tohoto stroje byla silně olétaná.

A-20G-35 Havoc, s/n 43-10208, 5D-S, „Es For Sugar“, 644th BS, 410th BG, France, second half of 1944. Upper surfaces invasion stripes were over painted to lower the visibility from above. The camouflage of this aircraft was heavily weathered.

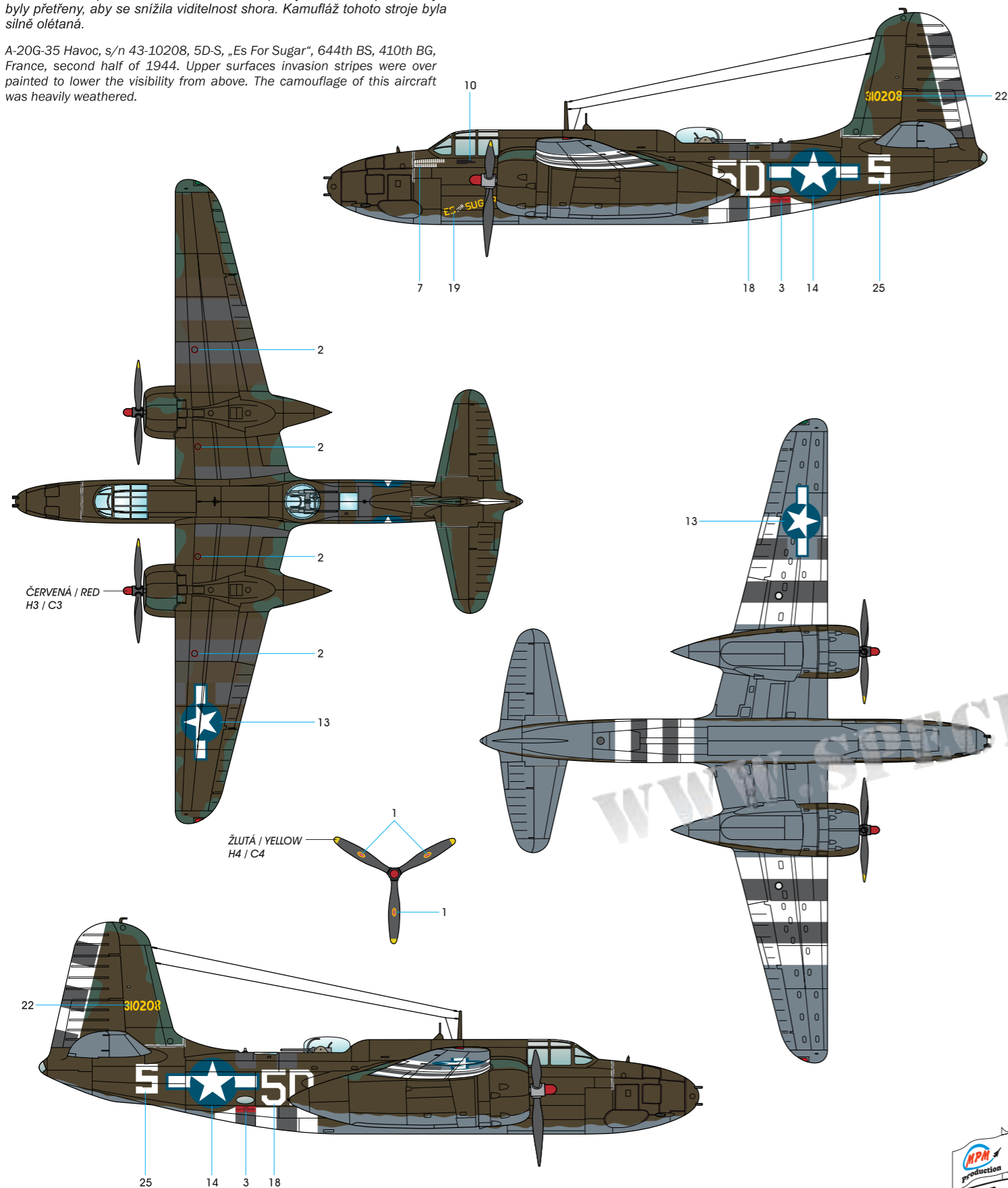

- A** OLIVOVÁ 41 OLIVE DRAB 41 H52 / C12
- B** STŘEDNÍ ZELENÁ 42 MEDIUM GREEN 42 H302 / C302
- C** SVĚTLE ŠEDÁ 43 NEUTRAL GREY 43 H53 / C13
- D** MATNÁ ČERNÁ FLAT BLACK H12 / C33
- E** MATNÁ BÍLÁ FLAT WHITE H11 / C62

72539 A-20G Havoc



**CAM. D**

A-20G-25 Havoc, ser. 43-9701, 5H-H, 668. BS, 416. BG, Anglie, červen 1944. Letoun nesl kompletní invazní pruhy na všech plochách.

A-20G-25 Havoc, s/n 43-9701, 5H-H, 668th BS, 416th BG, England, June 1944. The aircraft had full invasion stripes painted on all surfaces.

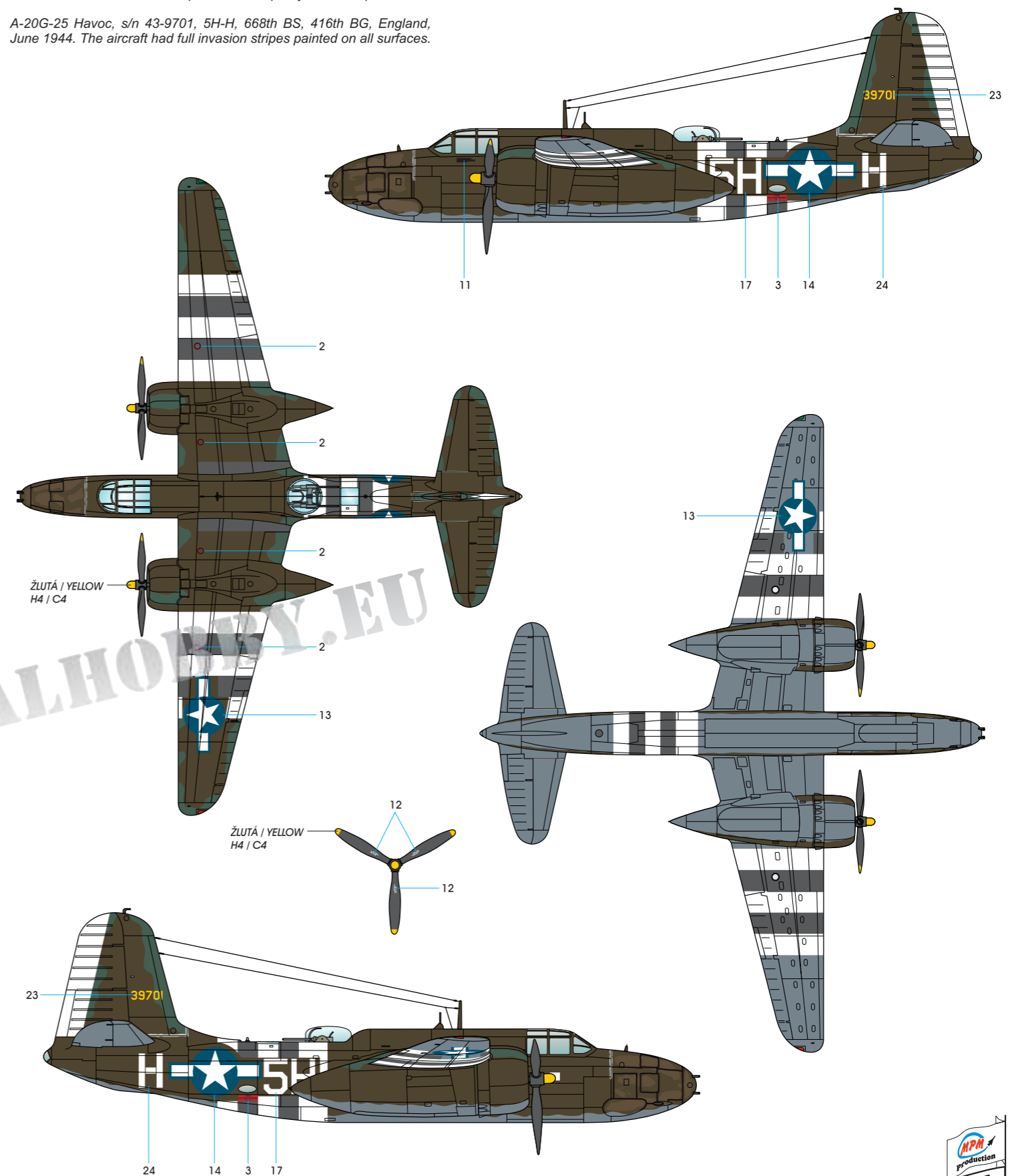

- A** OLIVOVÁ 41 OLIVE DRAB 41 H52 / C12
- B** STŘEDNÍ ZELENÁ 42 MEDIUM GREEN 42 H302 / C302
- C** SVĚTLE ŠEDÁ 43 NEUTRAL GREY 43 H53 / C13
- D** MATNÁ ČERNÁ FLAT BLACK H12 / C33
- E** MATNÁ BÍLÁ FLAT WHITE H11 / C62

72539 A-20G Havoc

