



Litaki
MODEL KIT

NJ-22 ORAO

72002
scale 1:72

ATTACK AIRCRAFT
TWIN SEATER VERSION

Dear modeller!

Following our first kit of Yugoslav Soko J-22 Orao ground-attack aircraft, LITAKI is happy to offer you our second product – 1/72-scale kit of NJ-22 Orao two-seater version.

We hope that this kit will also attract your interest!

Litaki is now working on several other model kits in various scales (1/48, 1/72, 1/144).

Stay tuned for our news!

Parts of the Model Kit

A

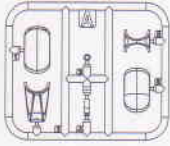

Decal

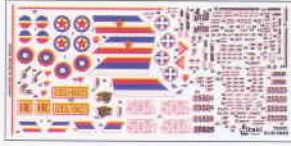

P-E parts

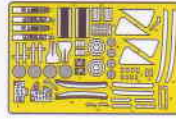

Mask



B

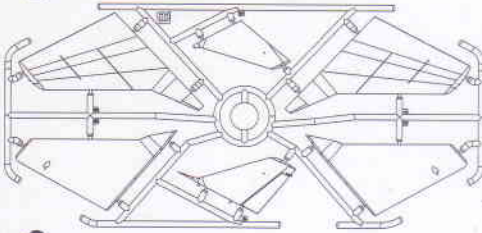

D

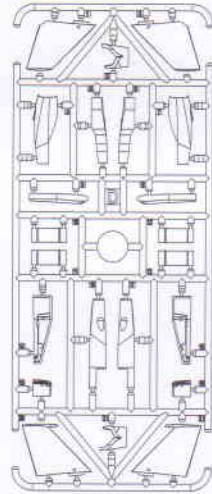

C

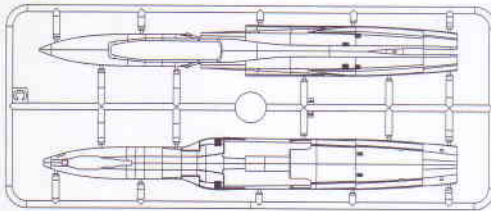

E

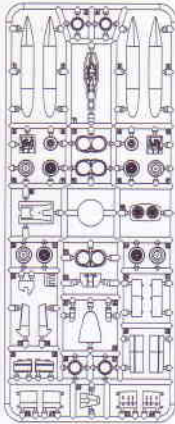

F

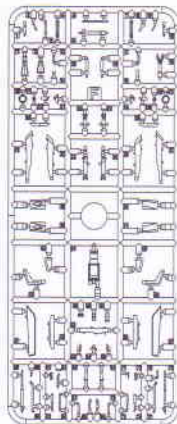

G

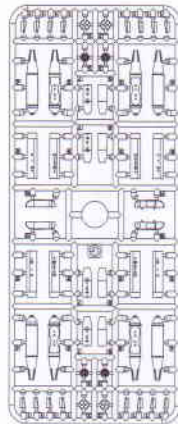

Used Symbols



Glue



Do not glue



Use
cyanoacrylate
glue



Make a hole



Variants



Use Weight



Bend



Multiple

H

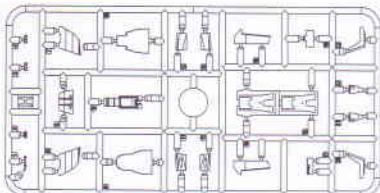

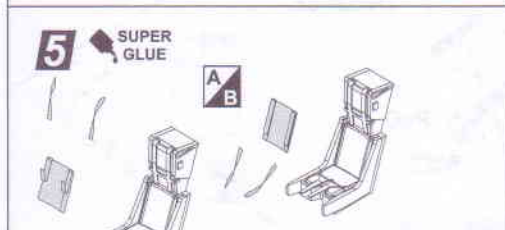
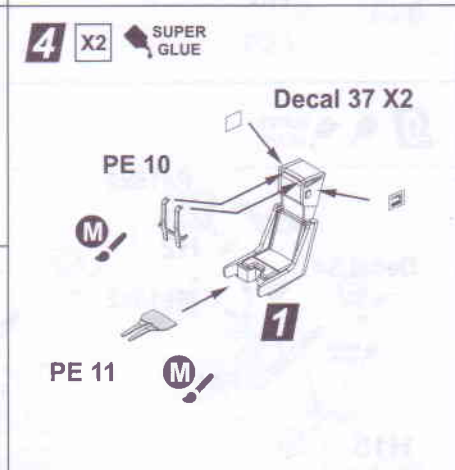
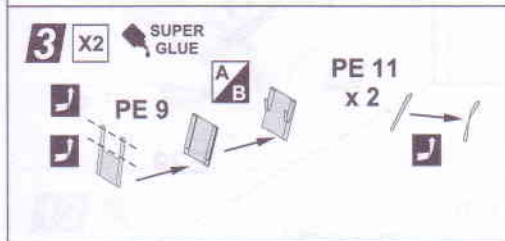
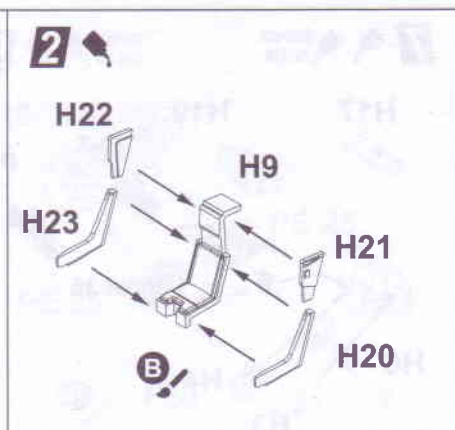
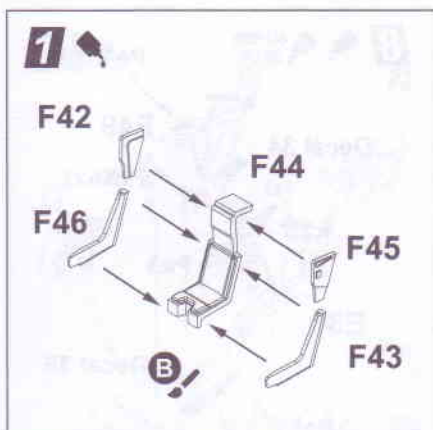

ATTENTION

The pilot's instrument panels were of different colors

I 90% + **B** 10%

B 90%+ **A** 10%

Before 1993, the cockpits were painted in Cockpit Green color. **J**

After 1993, following major overhaul of the aircraft, the cockpits were painted in Turquoise Green (similar to Soviet MiG-21 cockpits) **I**

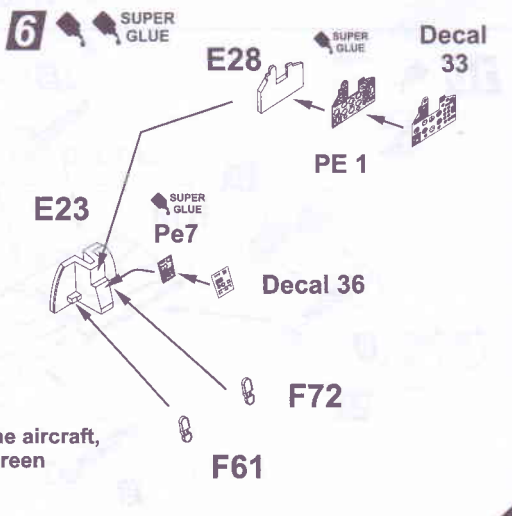

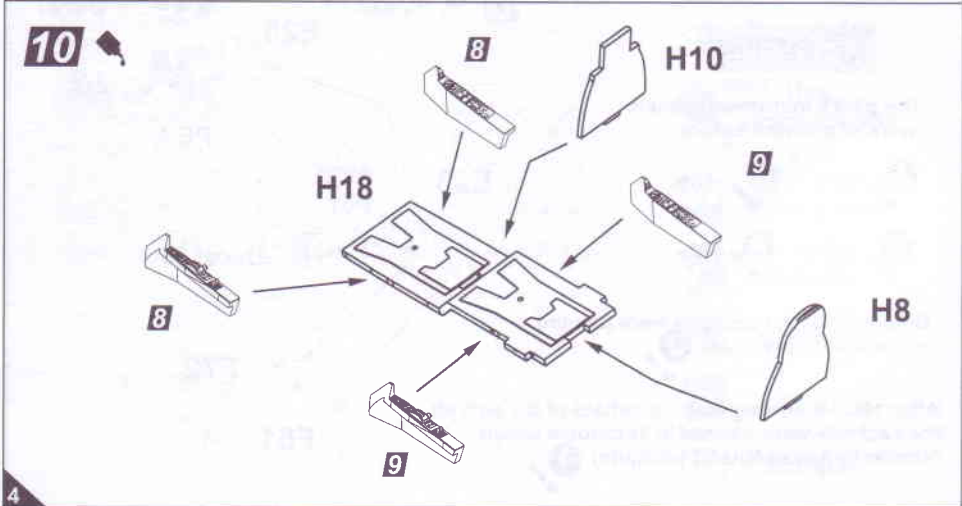
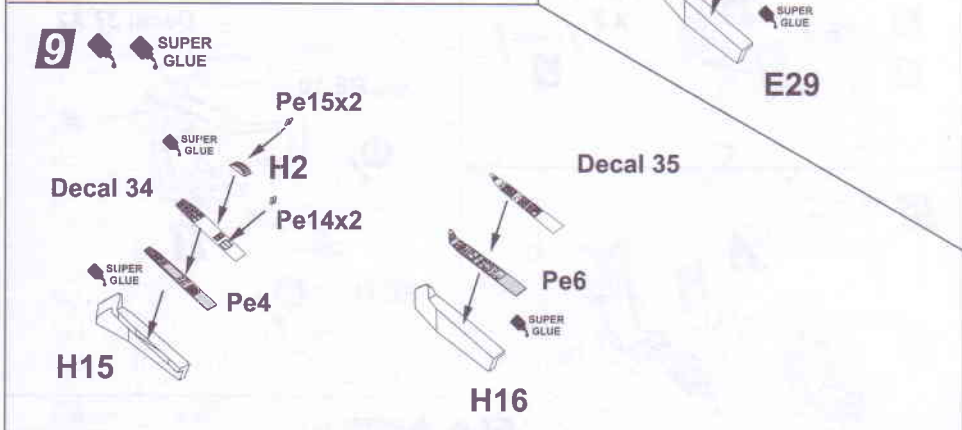
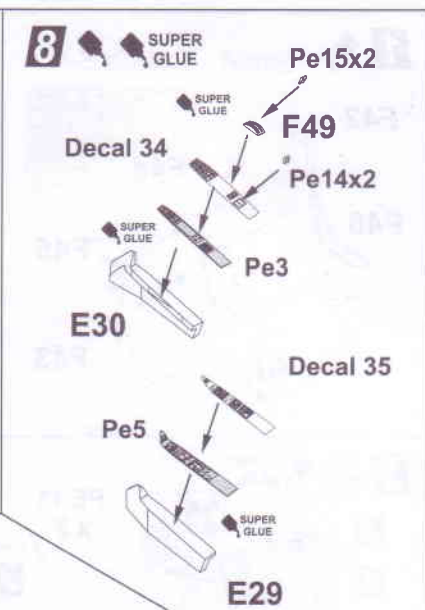
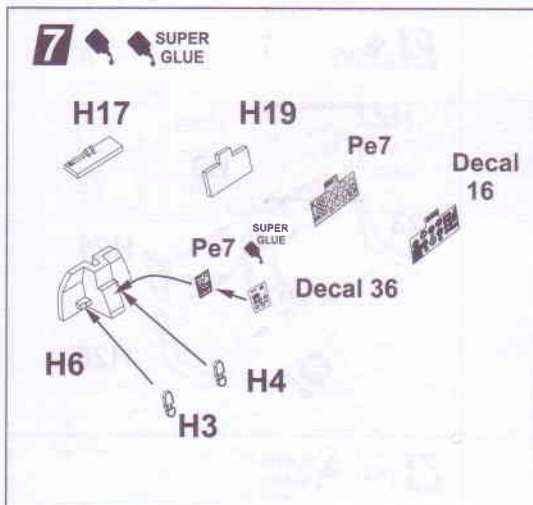

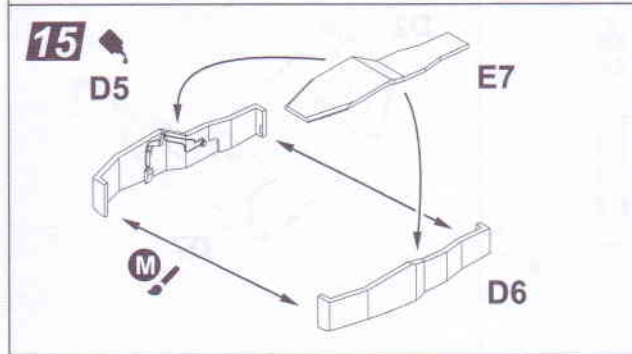
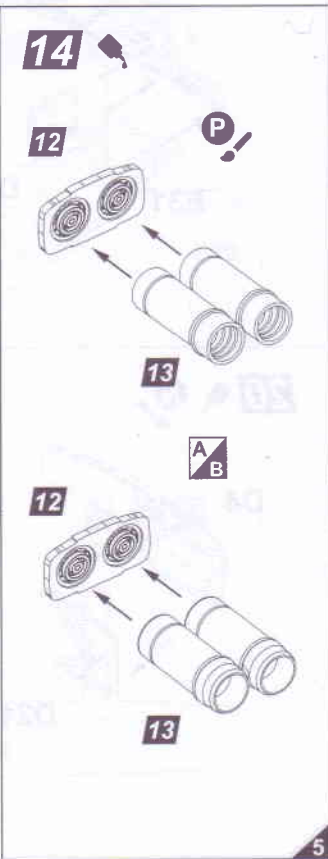
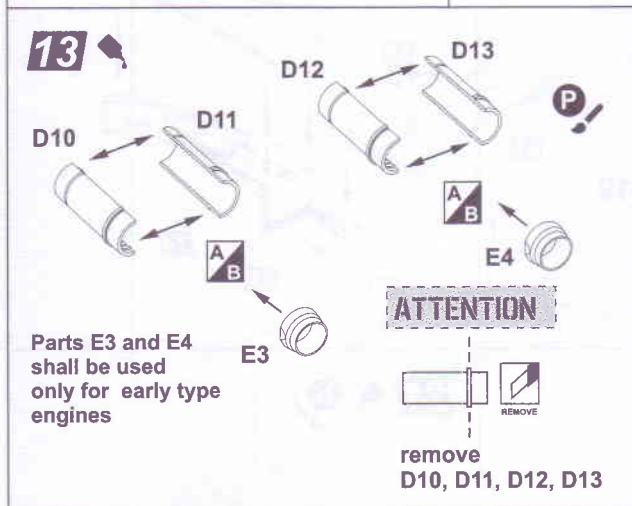
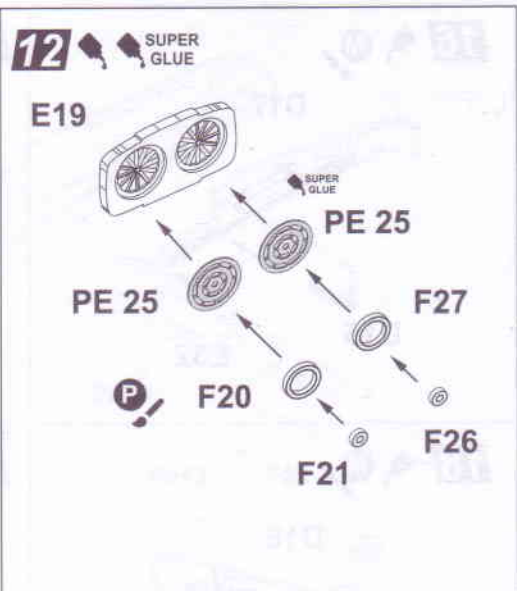
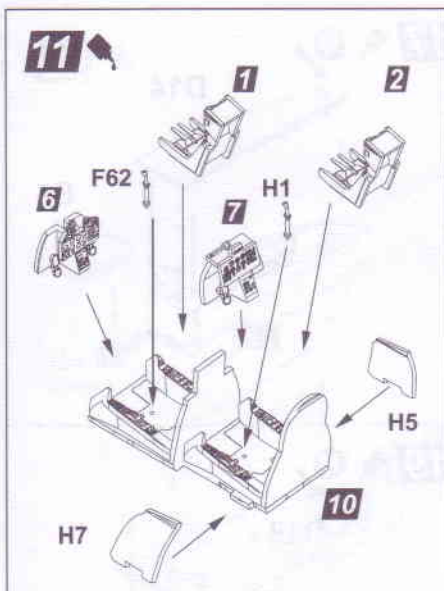

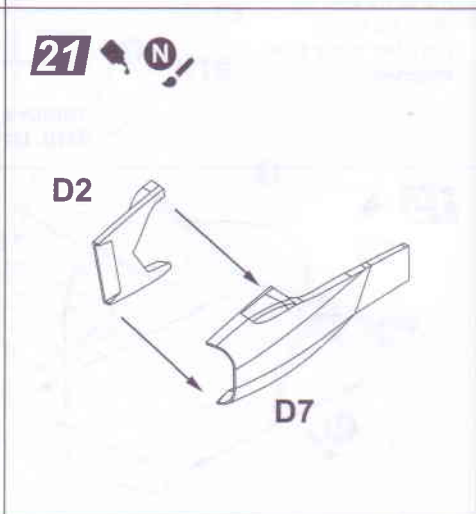
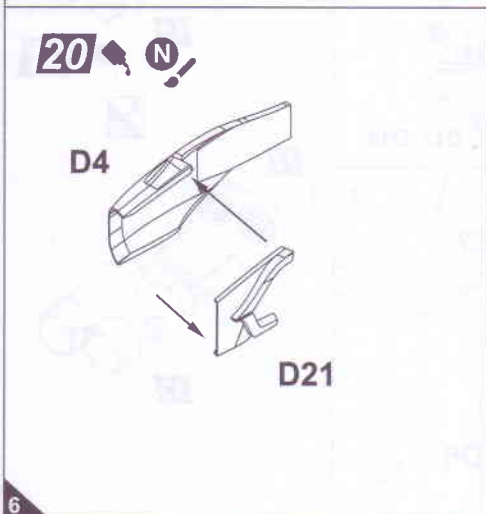
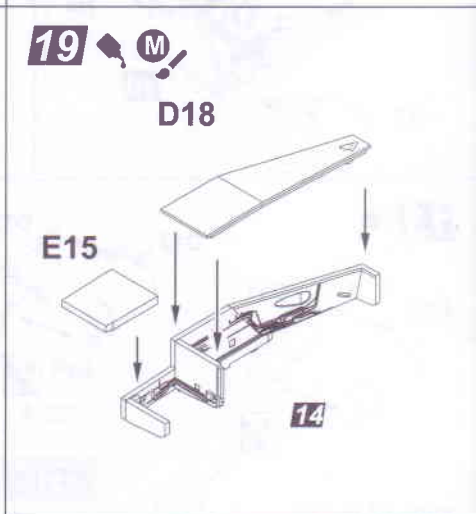
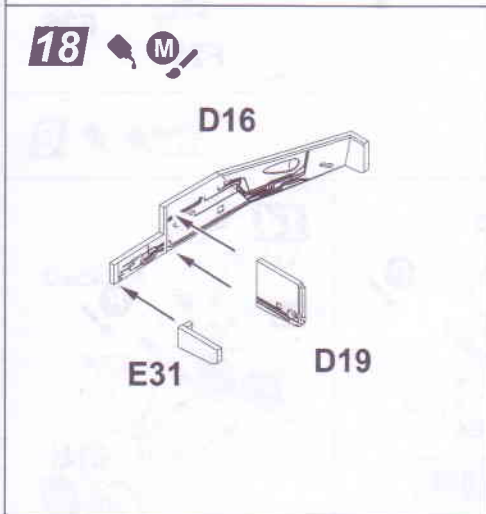
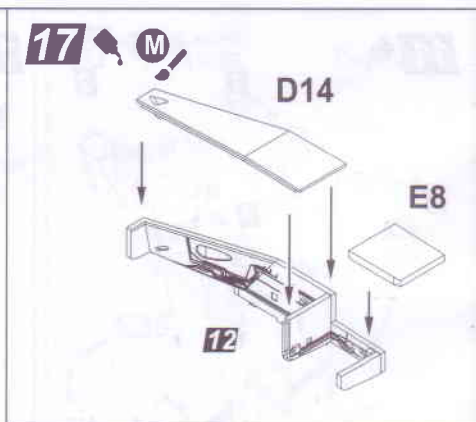
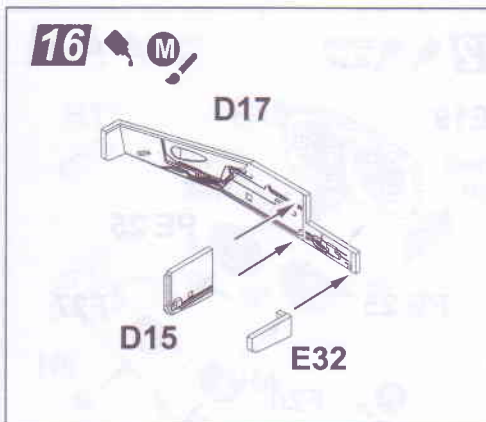

22

Use Weight

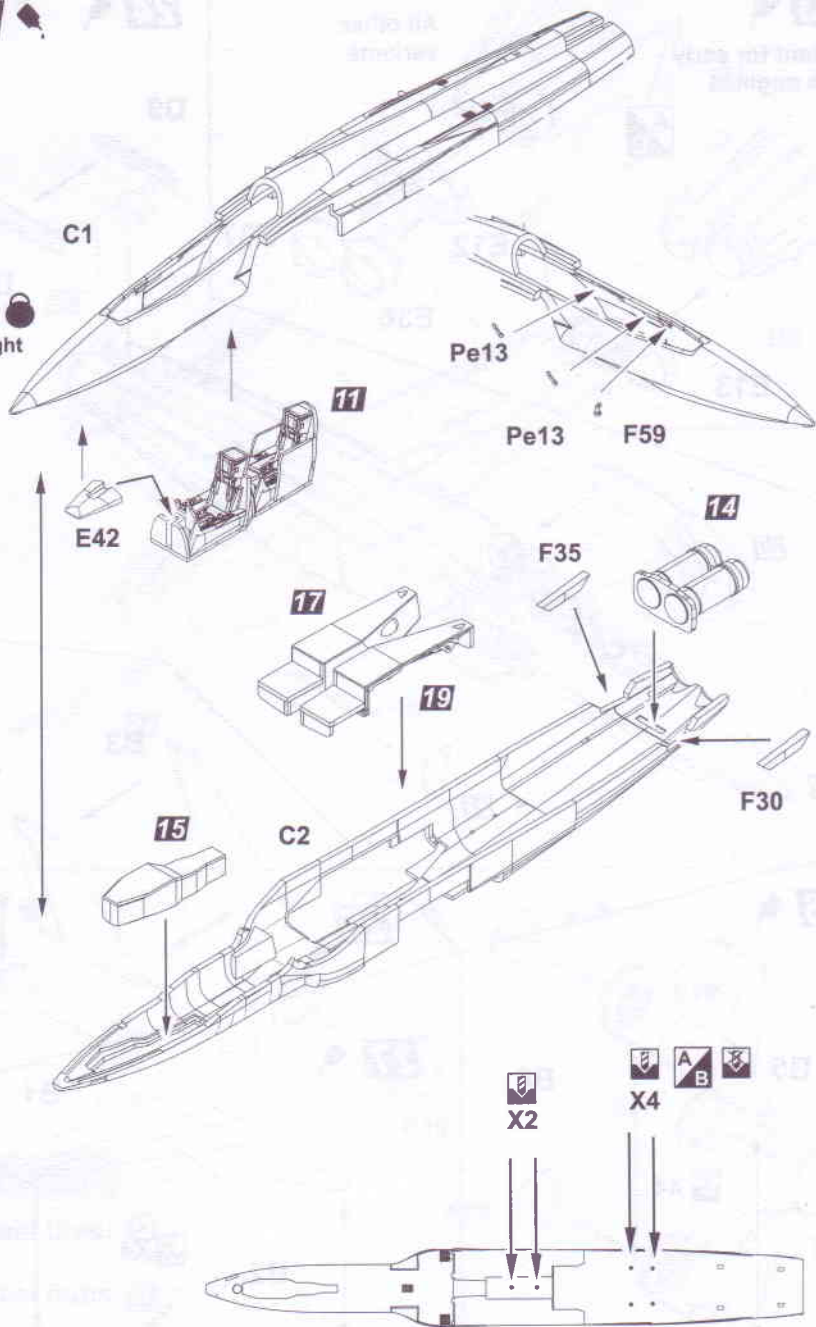

23

Variant for early
type engines

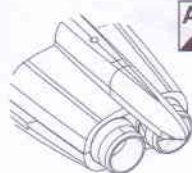

E13



All other
variants

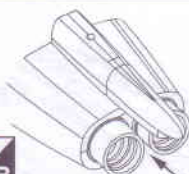

E12

E36

E37

24

D9



D8

20

22

21

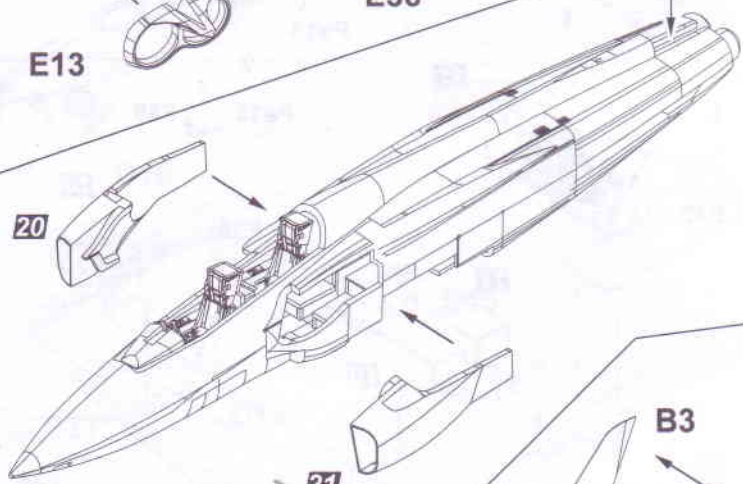

B3

25

B4



26

B5

B6

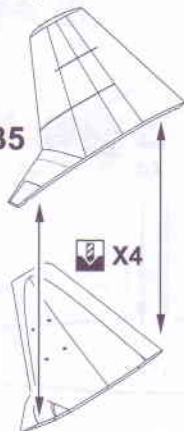

X4

27

B1

B2

X4

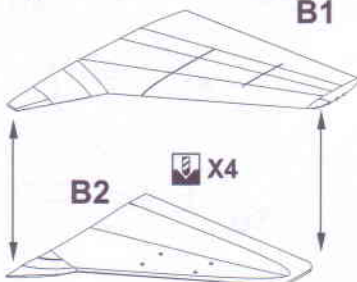

28

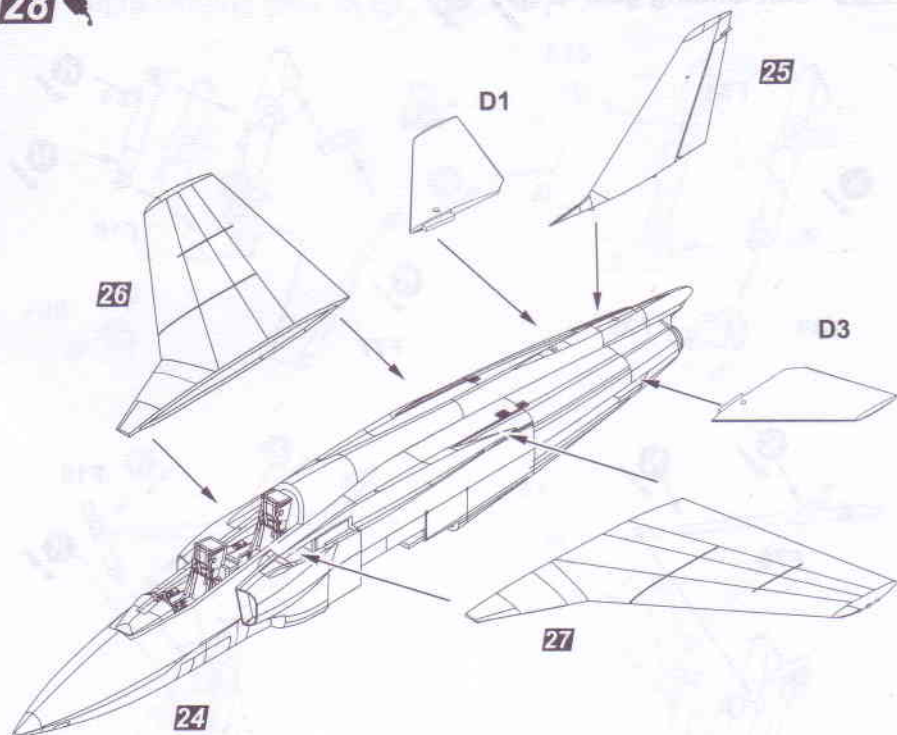

29

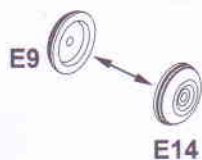

30

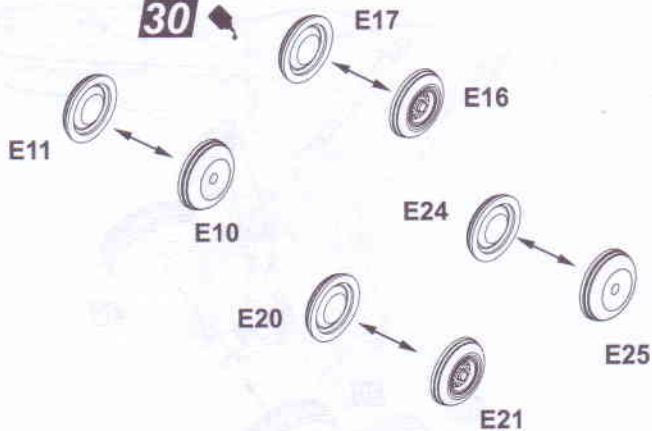



ATTENTION

Wheel tires:

Wheel hubs:

Use masks when painting wheels

31 Left landing gear  

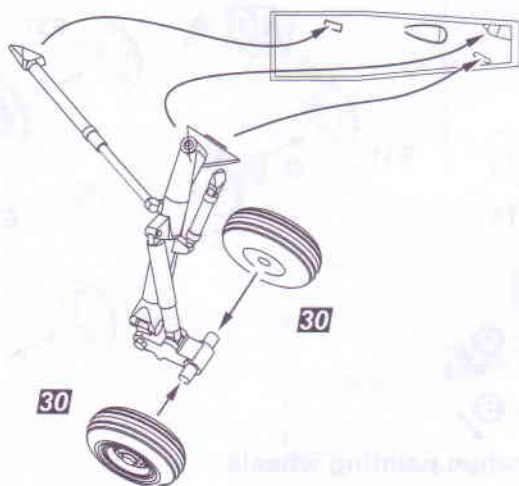
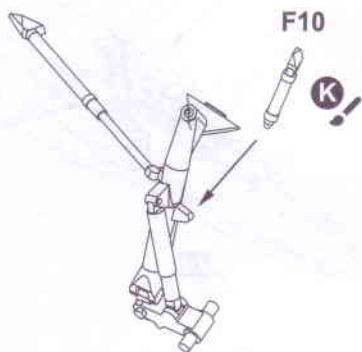
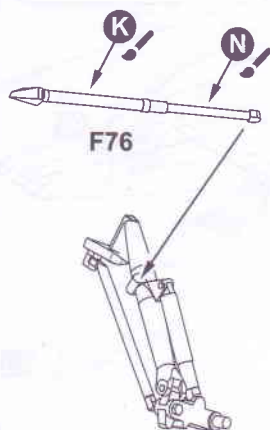
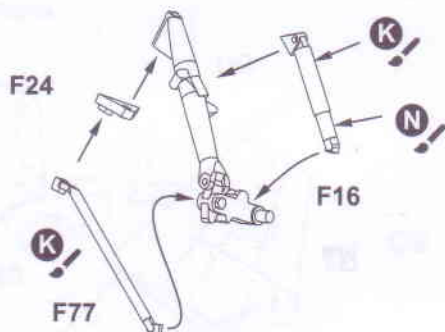
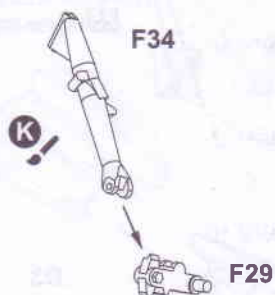

32 Right landing gear  **K**  **N**

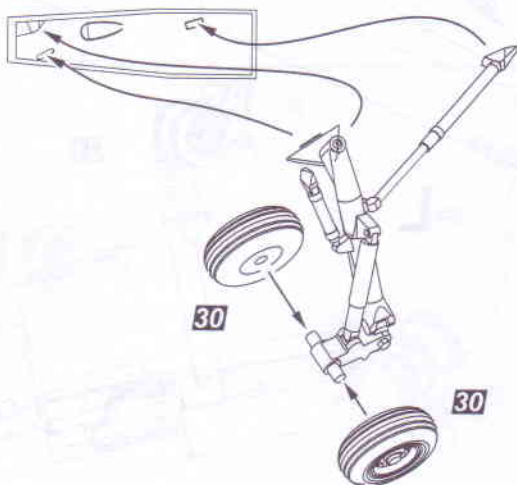
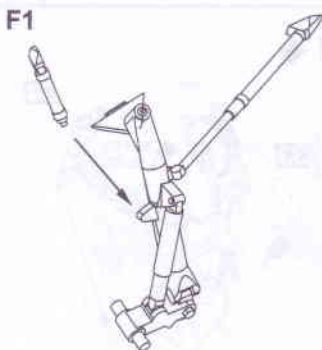
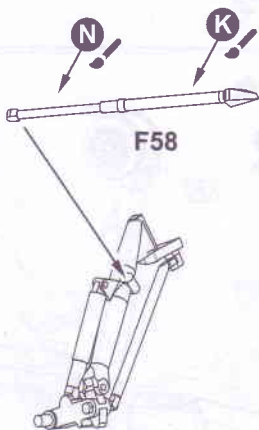
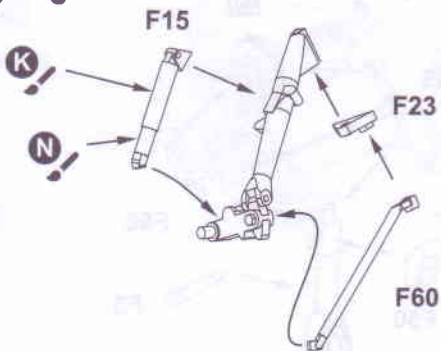
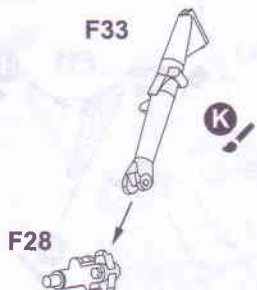

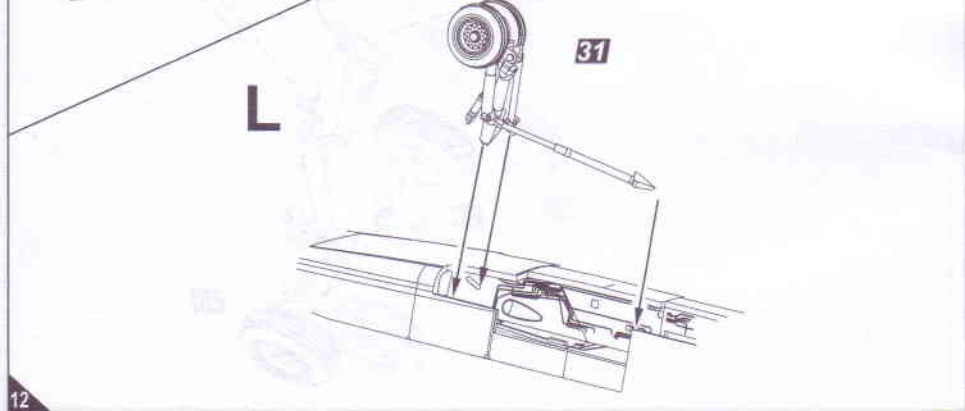
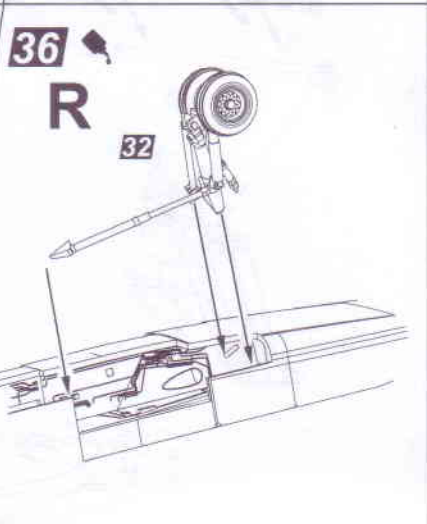
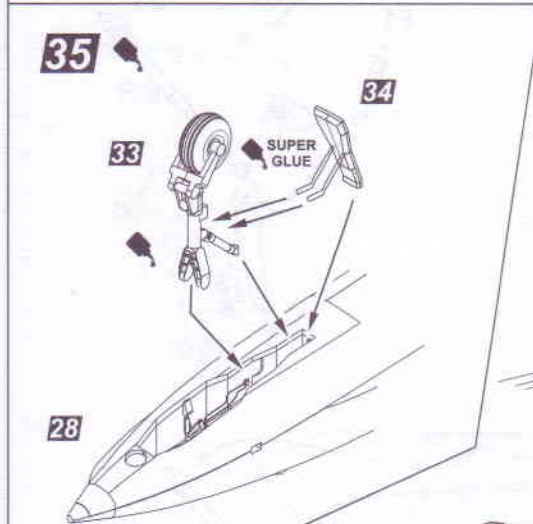
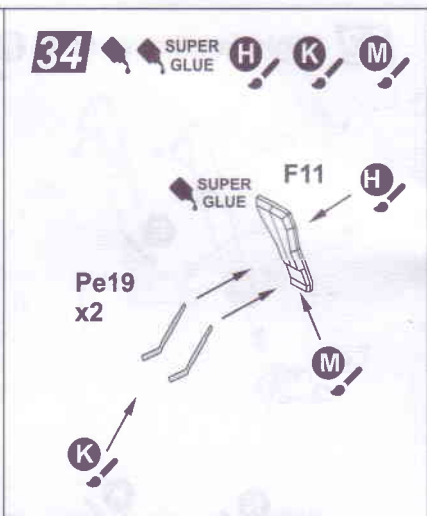
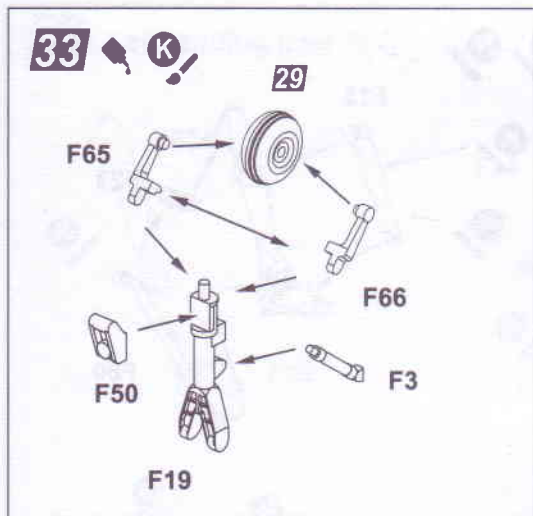

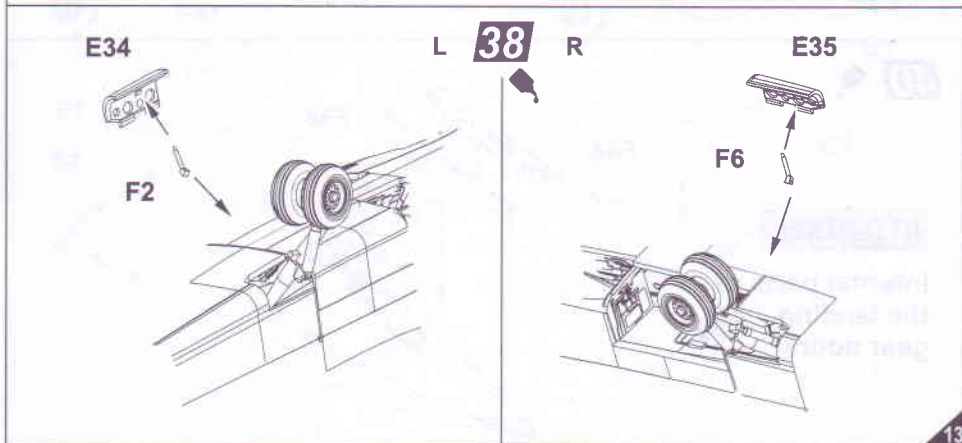
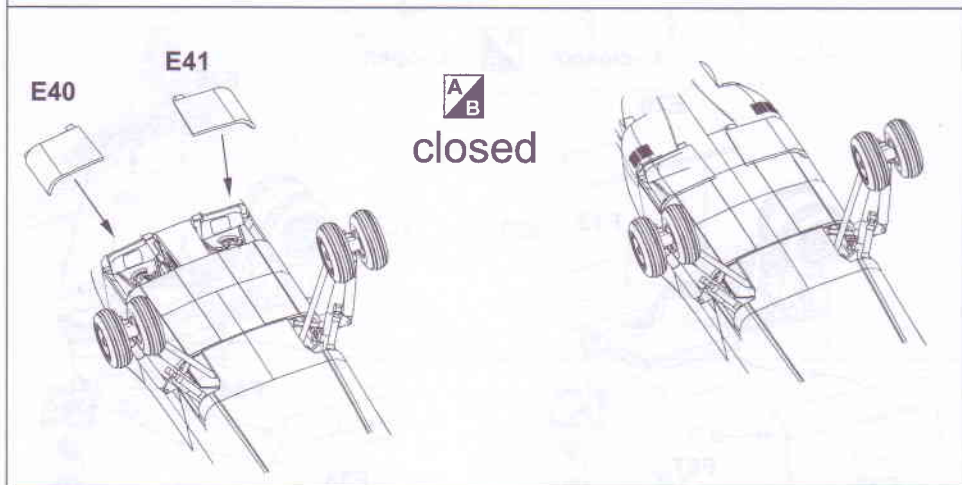
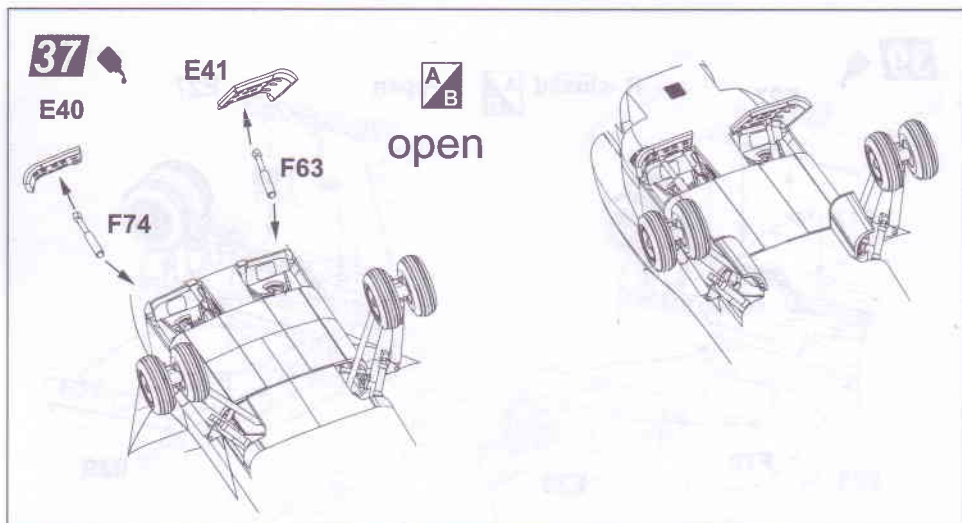

39

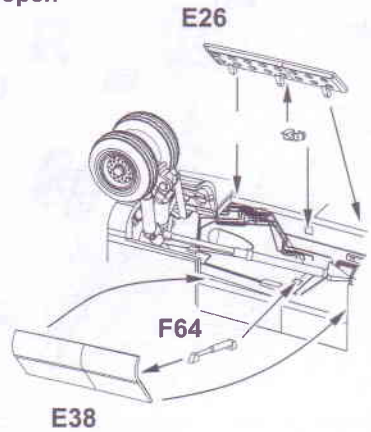
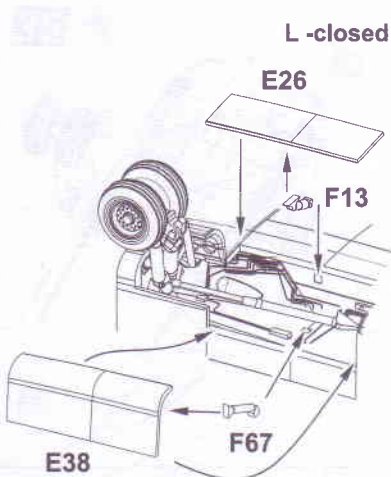
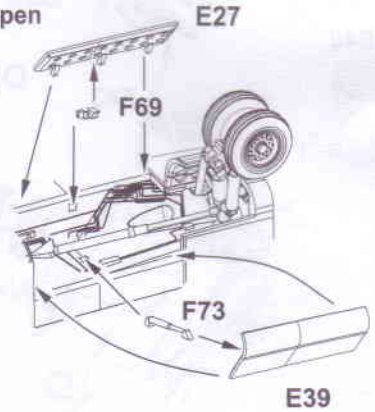
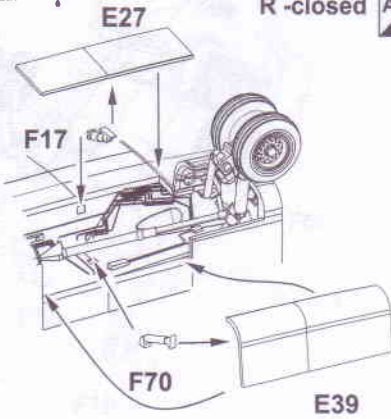

40

ATTENTION

Internal parts of the landing gear doors:

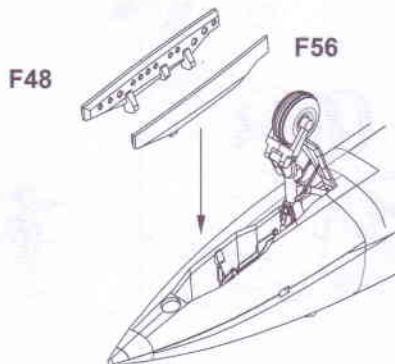

41

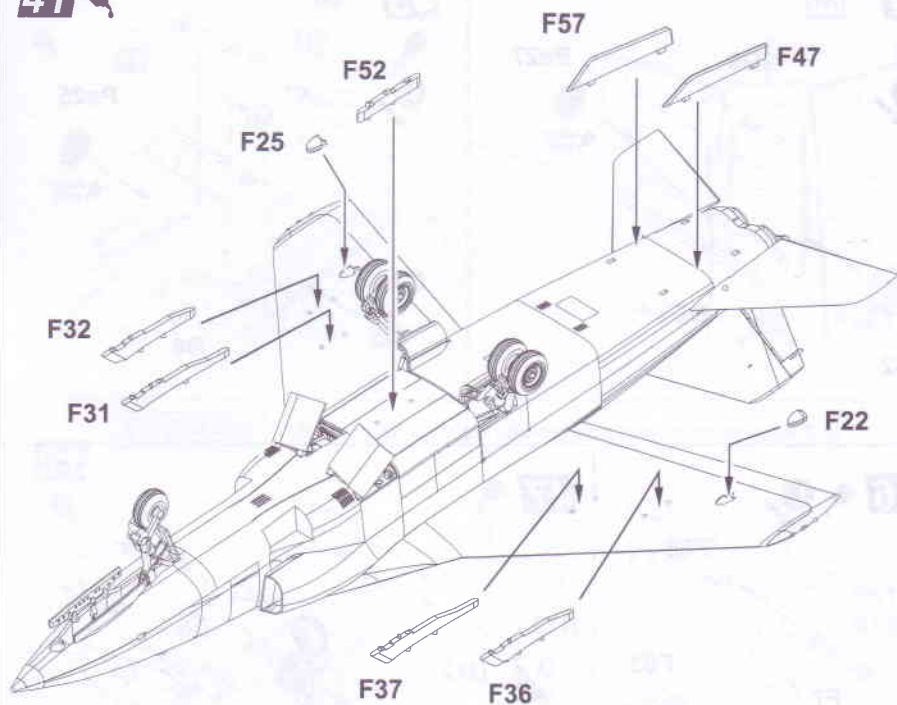

42 **X2**

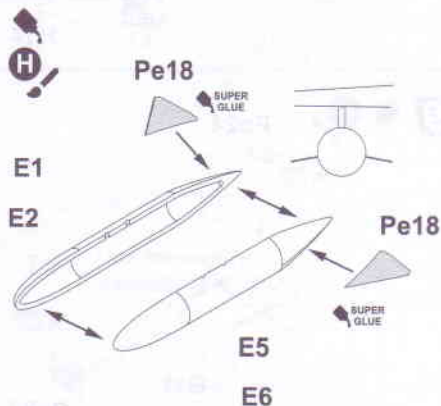

43 **X4**

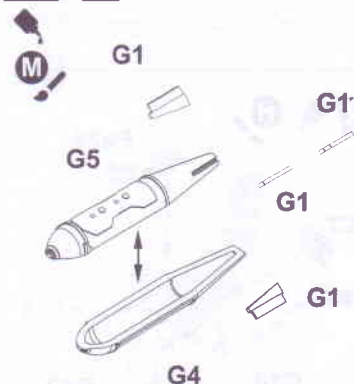

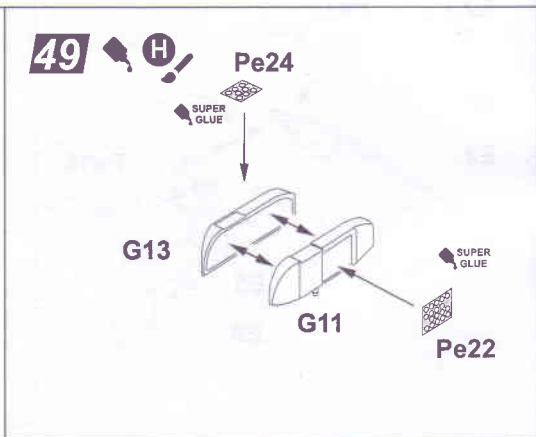
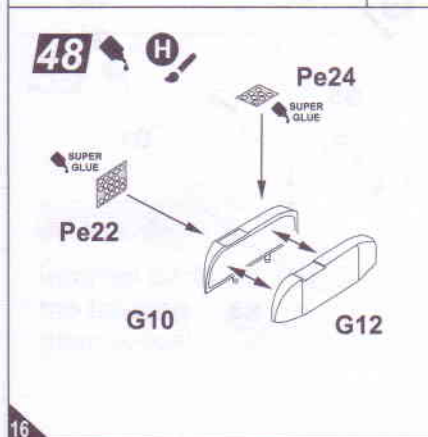
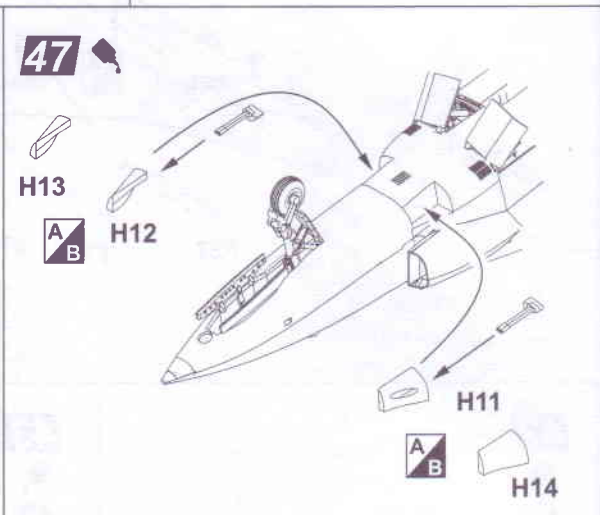
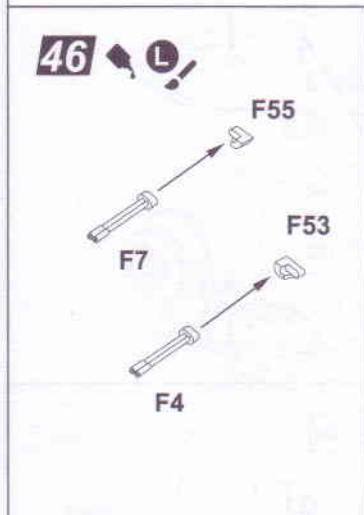
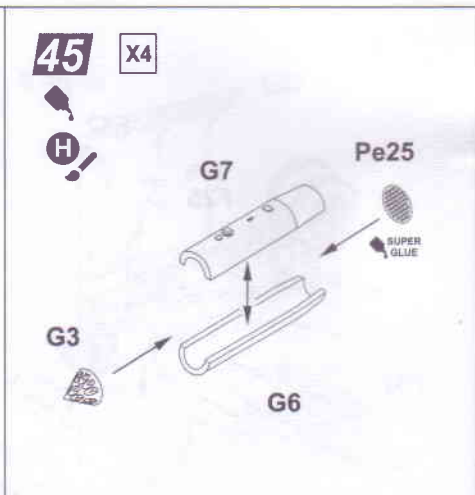
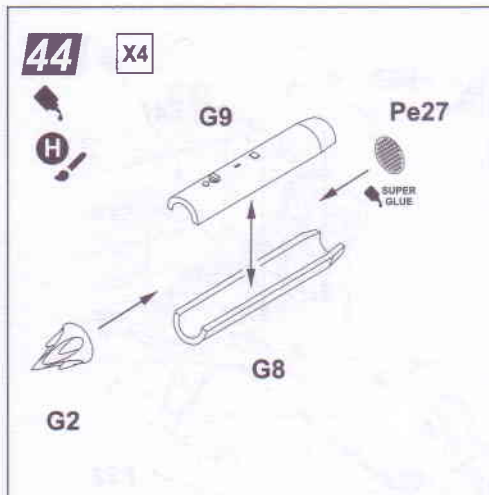

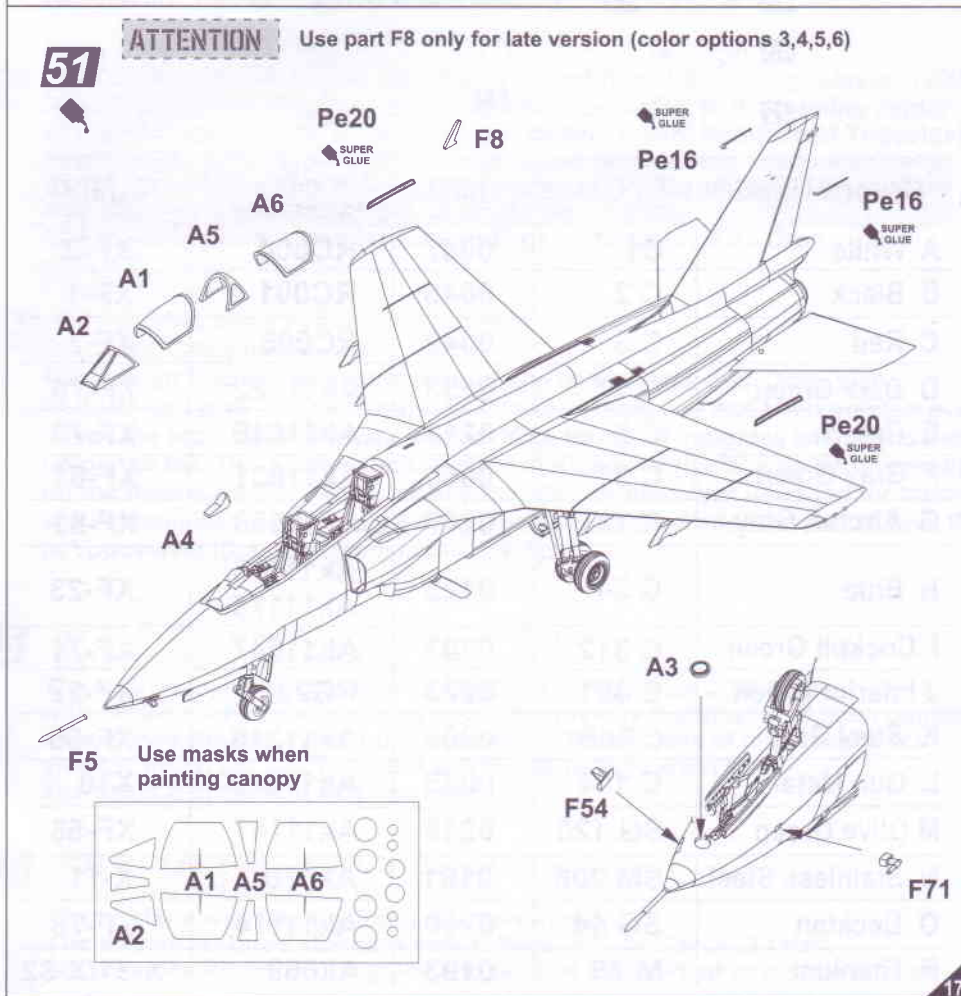
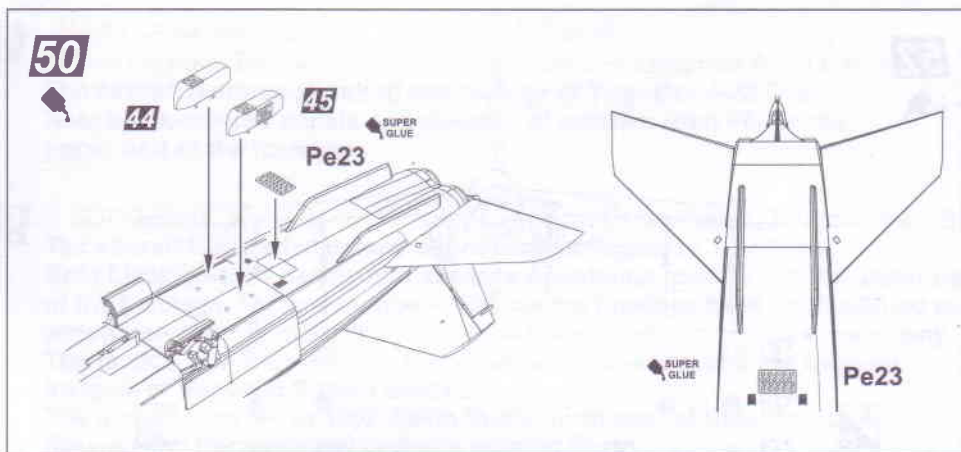

52

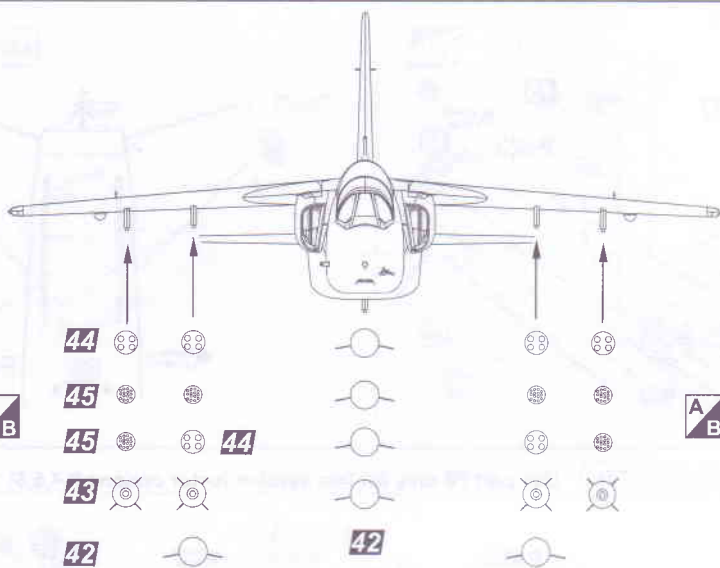

Colors Used	MR. Color	MIG	AK Interactive	TAMIYA
A White	C1	0047	RC004	XF-2
B Black	C 2	0046	RC001	XF-1
C Red	C 3	0049	RC006	XF-7
D Dark Green	C 17	0233	Ak11822	XF-70
E Green	C 6	0213	Ak11016	XF-73
F Gray Green	C 31	0060	Ak11831	XF-81
G Aircraft Gray	C 73	0207	Ak11853	XF-83
H Blue	C 34	0123	Ak11176/ Ak11175	XF-23
I Cockpit Green	C 312	0003	Ak11847	XF-71
J Interior Green	C 391	0223	RC206	XF-22
K Steel Gray	C 308	0203	Ak11210	XF-56
L Gun Metal	C 104	0045	Ak11212	X10
M Olive Green	SG 120	0248	Ak11147	XF-58
N Stainless Steel	SM 206	0191	Ak670	X-11
O Decktan	SG 44	0200	Ak11114	XF-78
P Titanium	M 78	0193	Ak669	X-31/X-32

- 1** NJ-22 Orao, ser/n 25504, Yugoslav Air Force, 242nd Fighter-Bomber Squadron, Golubovci-Podgorica Air Base, 1989
The aircraft features standard camouflage of Yugoslav J-22 Orao. Note black-colored panels and absence of antenna (part F8) on the upper part of the fuselage.
- 2** NJ-22 Orao, ser/n 25504, Republic of Srpska Air Force, Banja Luka, 1996.
The aircraft featured standard camouflage of Yugoslav J-22 Orao. Note black-colored panels and absence of antenna (part F8) on the upper part of the fuselage. Tactical numbers '504' on the fuselage have been painted over with green color in order to camouflage the aircraft and confuse the enemy. The tactical numbers '504' on the wings were retained, and the national insignia of Republic Srpska applied.
The aircraft crashed in 1992, 50km to the north-east of Banja Luka (Bosnia and Herzegovina) during a training flight.
- 3** NJ-22 Orao, ser/n 25526, GTA-002, Federal Republic of Yugoslavia, 1999.
The airplanes which carried GTA inscription belonged to the training center of the Air Force and Air Defence Forces of the Federal Republic of Yugoslavia. The airplane, after removal of all valuable equipment, was used as a decoy for US and NATO aviation. It was seriously damaged during NATO strike on Batajnica Air Base on the night of 24 - 25 March 1999.
The aircraft featured standard camouflage of Yugoslav J-22 Orao.
- 4** NJ-22 Orao, ser/n 25525, Serbian Air Force.
Batajnica Belgrade Air Base, 2007
The aircraft featured standard camouflage of Yugoslav J-22 Orao, with Serbian Air Force insignias applied. Previous insignias had been painted over, hence the local touch-ups are visible. Note traces of insignias which showed up on the tail. The airplane featured the markings IR (Instalacija Razoruzana) on the fuselage sides, which means that this airplane was intended for training and reconnaissance flights. IR markings were applied after the end of Civil War in Yugoslavia (Dayton Agreement of 1995).
- 5** NJ-22 Orao, ser/n 25528, Serbian Air Force.
Batajnica Belgrade Air Base, 2012.
The aircraft featured standard camouflage of Yugoslav J-22 Orao, with Serbian Air Force insignias applied. Previous insignias had been painted over, hence the local touch-ups are visible. Note traces of insignias which showed up on the tail. The paint cover was heavily worn out.
The cannon armament was removed.
- 6** NJ-22 Orao, ser/n 25528, Serbian Air Force,
Batajnica Belgrade Air Base, 2023.
The airplane was fresh painted after overhaul.
The aircraft featured standard camouflage of Yugoslav J-22 Orao, with Serbian Air Force insignias and tactical numbers of new style applied.

Tu-22M2



Backfire

1:144

NEW 2024

1:48

1:72

1:144

The NJ-22 Orao is two-seater version of J-22 Orao ground-attack aircraft, which was a joint project of Yugoslavia and Romania – the countries which tried to pursue an independent policy in the aviation industry during the Cold War.

Development of the J-22 Orao began in 1970 by engineers and designers of the Yugoslav Aeronautical Technical Institute and the Romanian Institute of Science and Technology.

The aircraft was powered by British Rolls-Royce Viper Mk 632-4IR engines, which were in license production in Yugoslavia and Romania.

It was also equipped with British Martin-Baker ejection seats and Soviet GSh-23 cannons. This fact emphasizes the uniqueness and originality of the aircraft design.

The first prototype of the two-seater version performed its maiden flight in November 1976. The NJ-22 alongside with the J-22 Orao participated in almost all conflicts that unfolded at the territory of the former Yugoslavia.

In addition to the training missions, the NJ-22 was used as ground-attack aircraft, bomber and reconnaissance airplane. In order to increase its bomb load, when the airplane was piloted by single pilot, the ejection seat was removed from the rear cockpit.

At the present time the NJ-22 Orao remains in service with Serbian Air Force, and modernization of the type continues.

e-mail: info@litaki.com.ua

www.litaki.com.ua

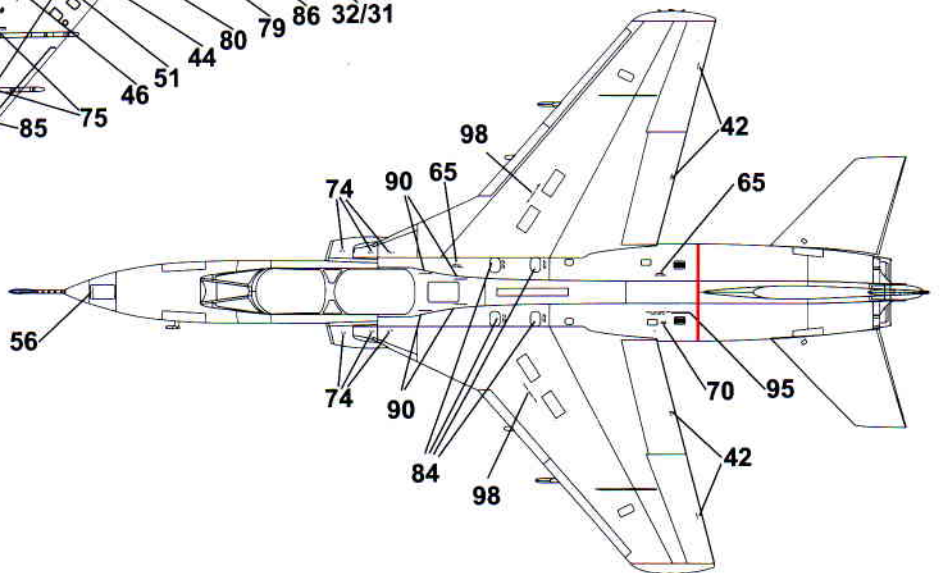
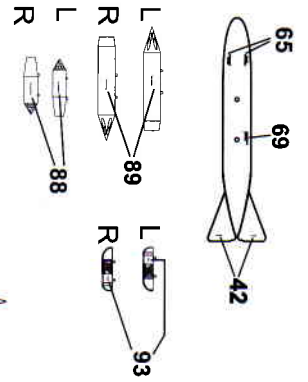
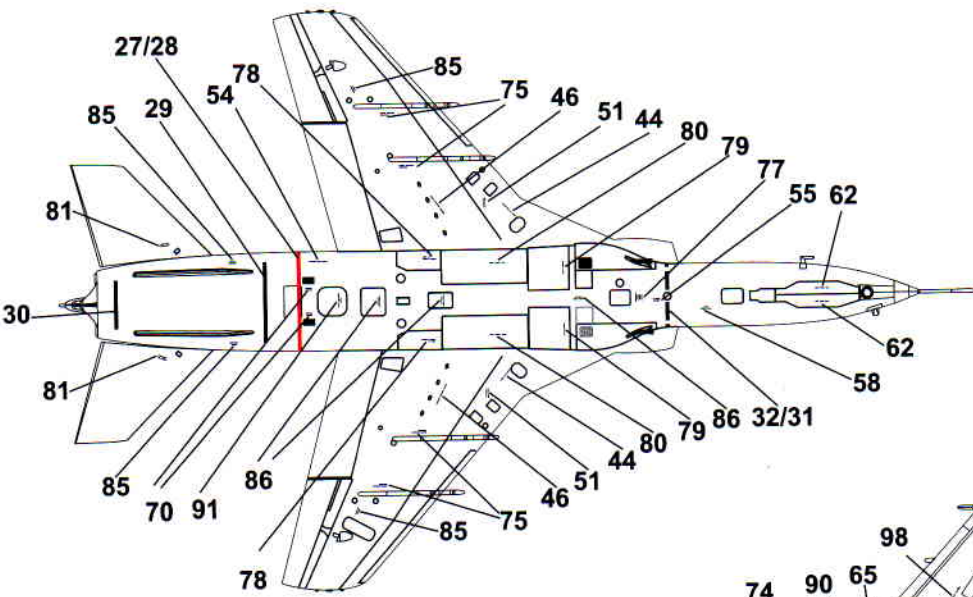
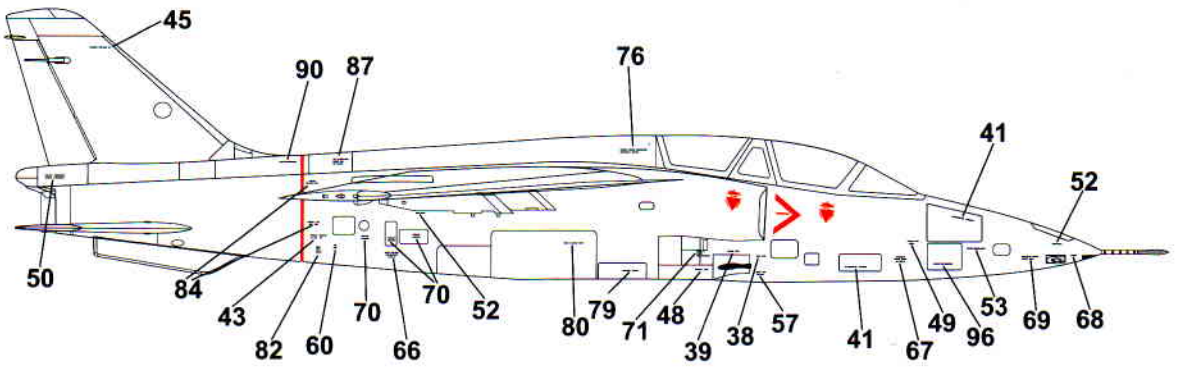
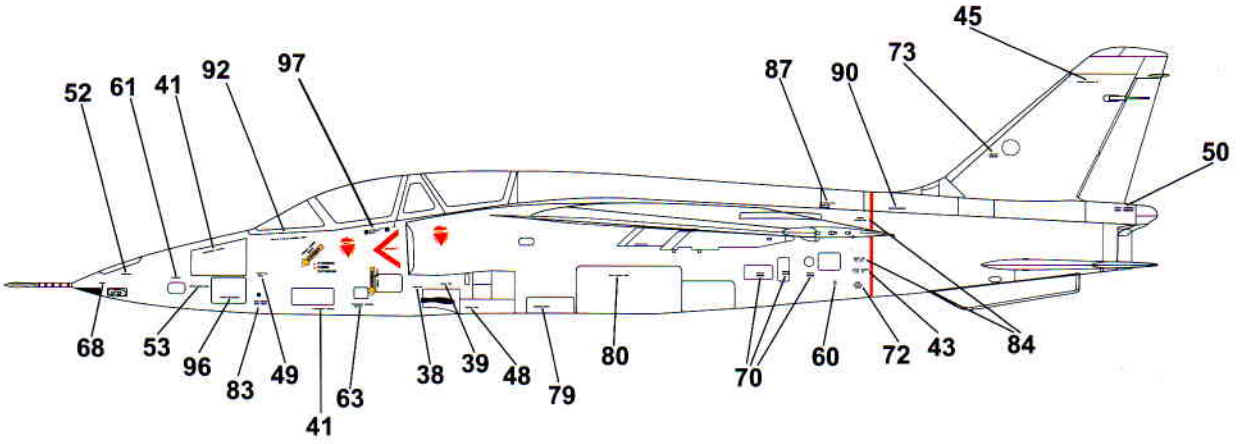

1 NJ-22 Orao, ser/n 25504, Yugoslav Air Force, 242nd Fighter-Bomber Squadron, Golubovci-Podgorica Air Base, 1989

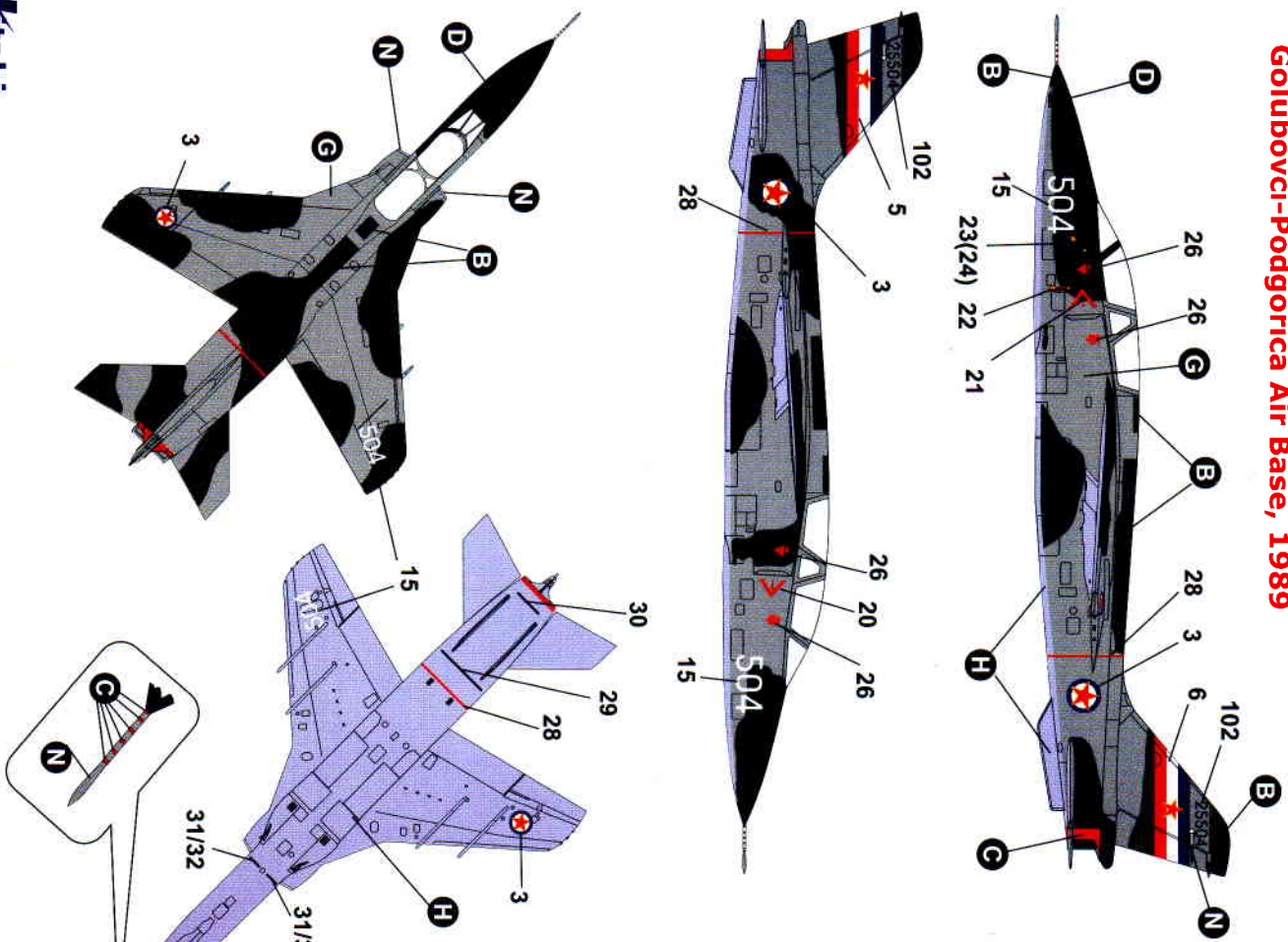

2 NJ-22 Orao, ser/n 25504, Republic of Srpska Air Force, Banja Luka, 1996.

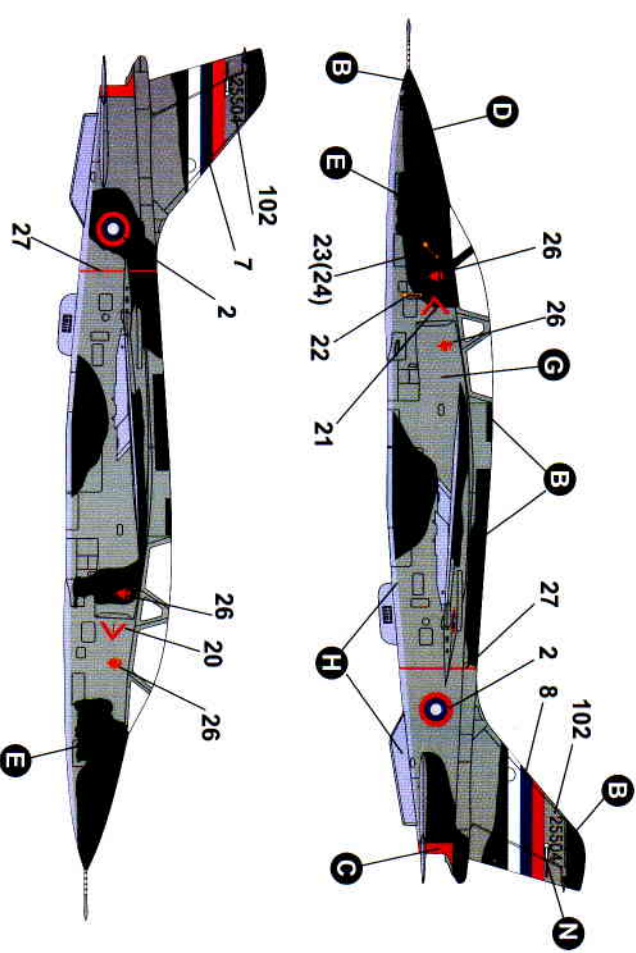

3 NJ-22 Orao, ser/n 25526, GTA-002, Republic of Yugoslavia, 1999.

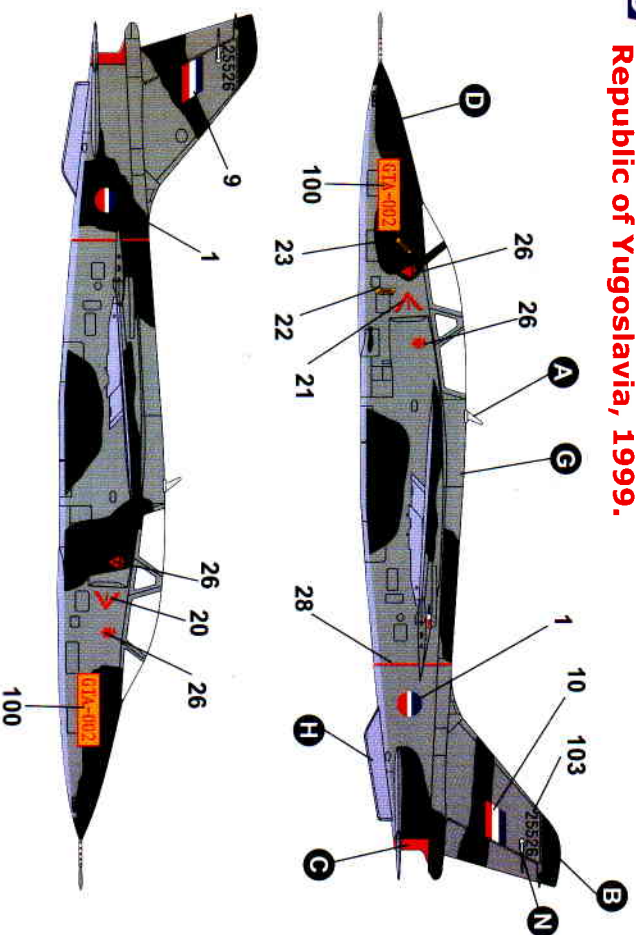

4 NJ-22 Orao, ser/n 25525, Serbian Air Force, Batajnica Belgrade Air Base, 2007.

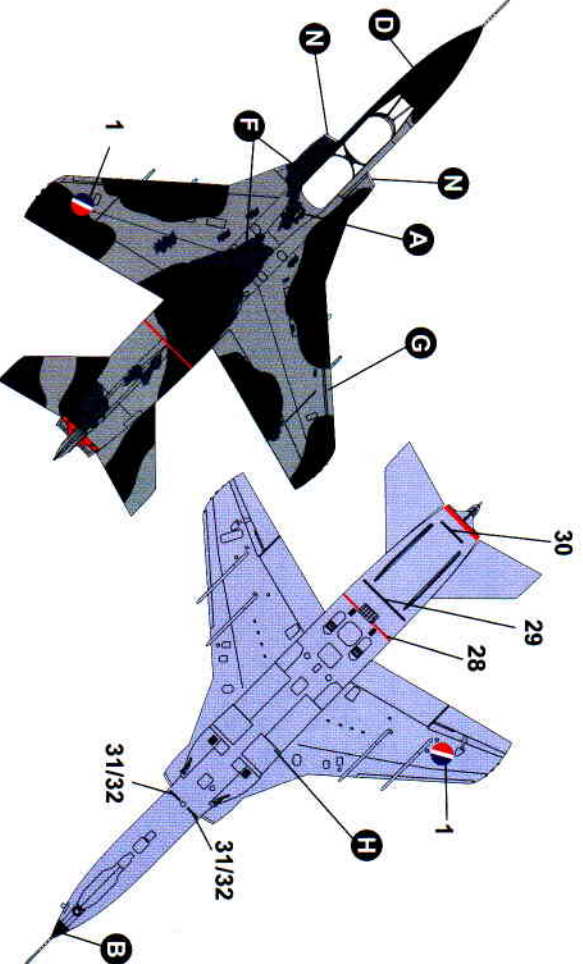
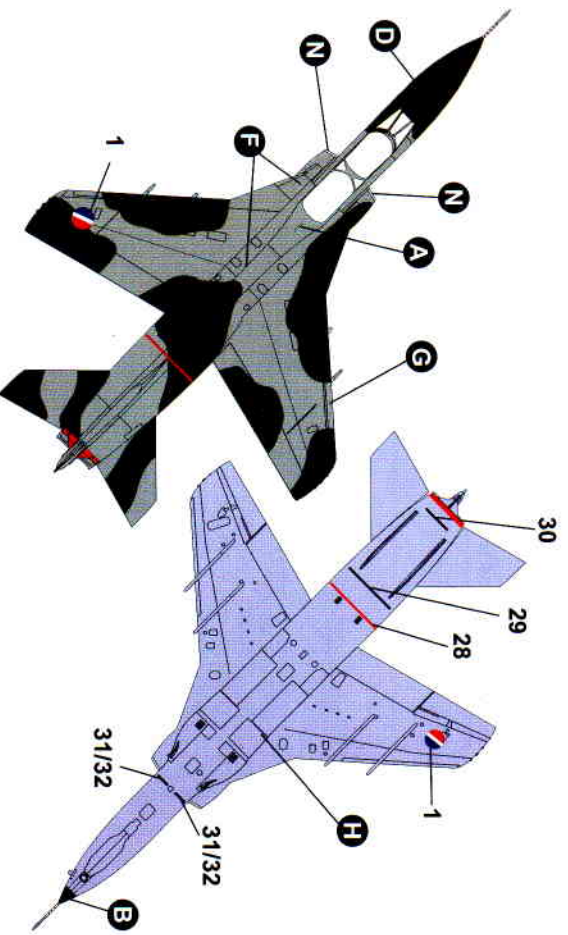
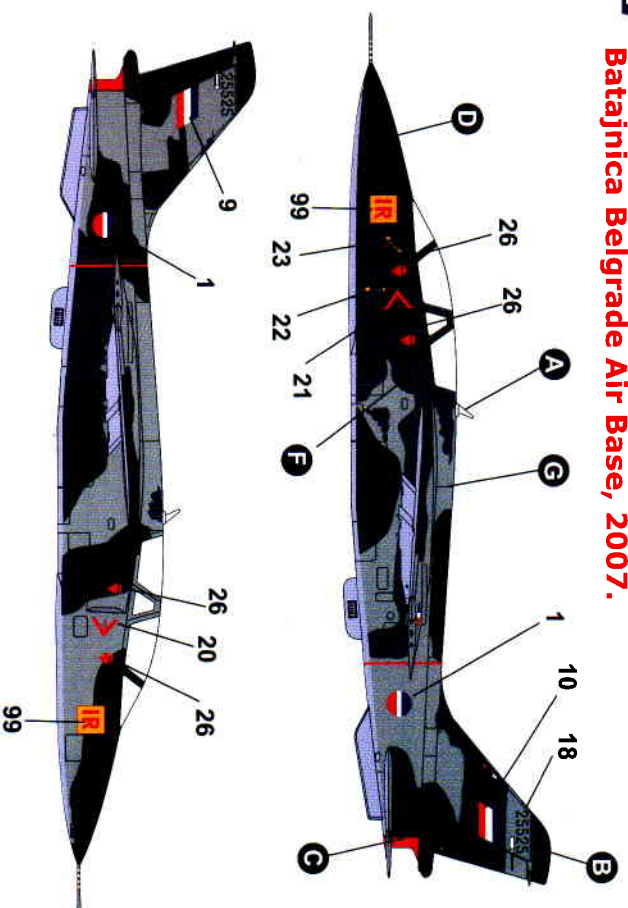

5 NJ-22 Orao, ser/n 25528, Serbian Air Force, Batajnica Belgrade Air Base, 2012.

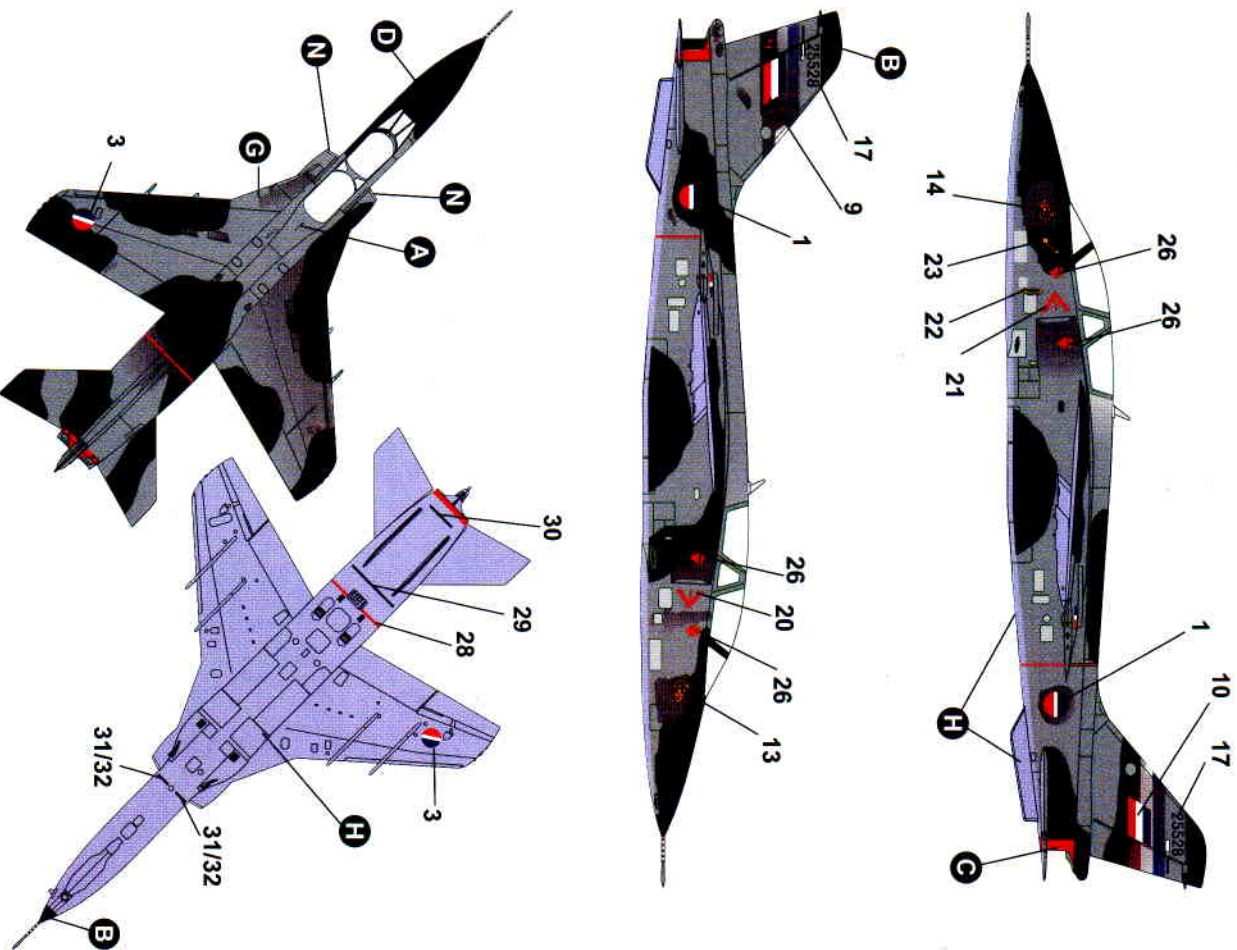

6 NJ-22 Orao, ser/n 25528, Serbian Air Force, Batajnica Belgrade Air Base, 2023.

