

RIGHT SIDE - R83
LEFT SIDE - R84

R84 ↔ R83

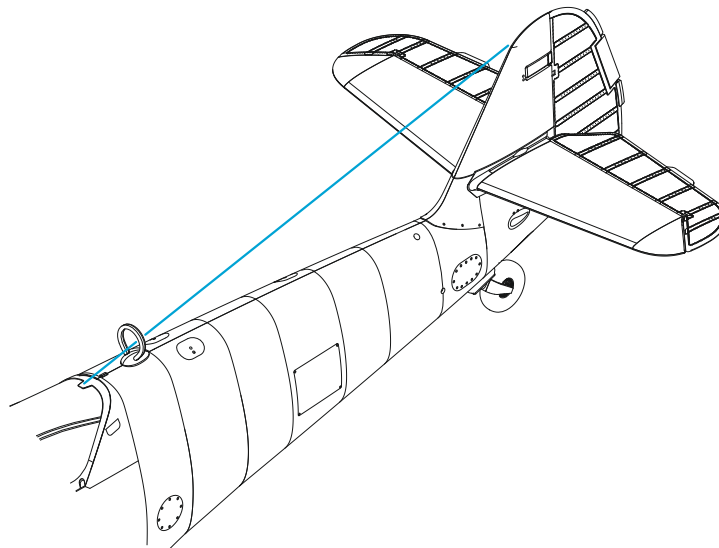
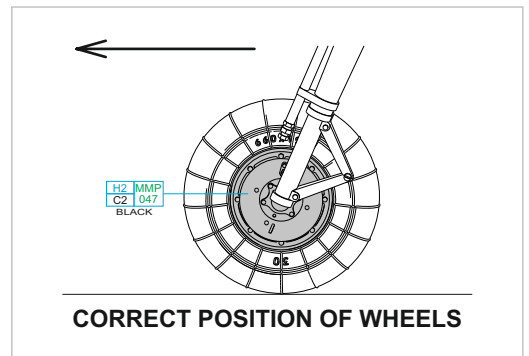
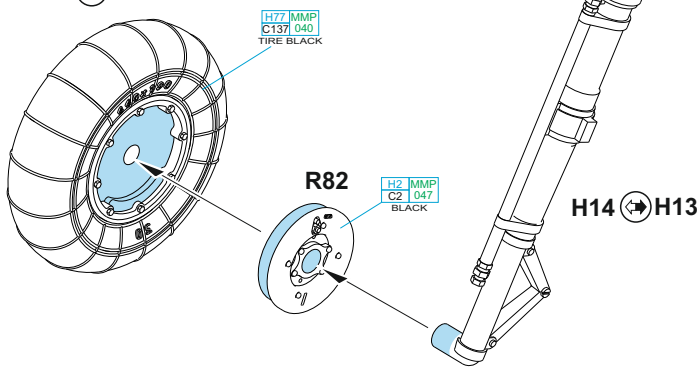

11./JG 300, Prague – Kbely, Czechoslovakia, May 1945

The aircraft found in front of the hangar at Prague-Kbely airport in the end of war comes from the production series 152xxx. The aircraft from this manufacturing batch had wings featuring larger bulges on the upper sides enabling the installation of the larger wheels i.e. the same type used on Bf 109G-10 planes manufactured at WNF factory and it's Diana branch. The fuselage and wings were probably spray painted in RLM 81/82 colors even though some researchers incline towards a single color camouflage variation sprayed in RLM 81. The wing lower surfaces were not painted at all with the exemption of parts coming from subcontractors which were painted in RLM 76. The engine cowling, coming from a different airframe, is camouflaged in RLM 74/75/76 colors. Of the serial number painted on the vertical tail surface only first three digits (152) and the last one (6) are legible.

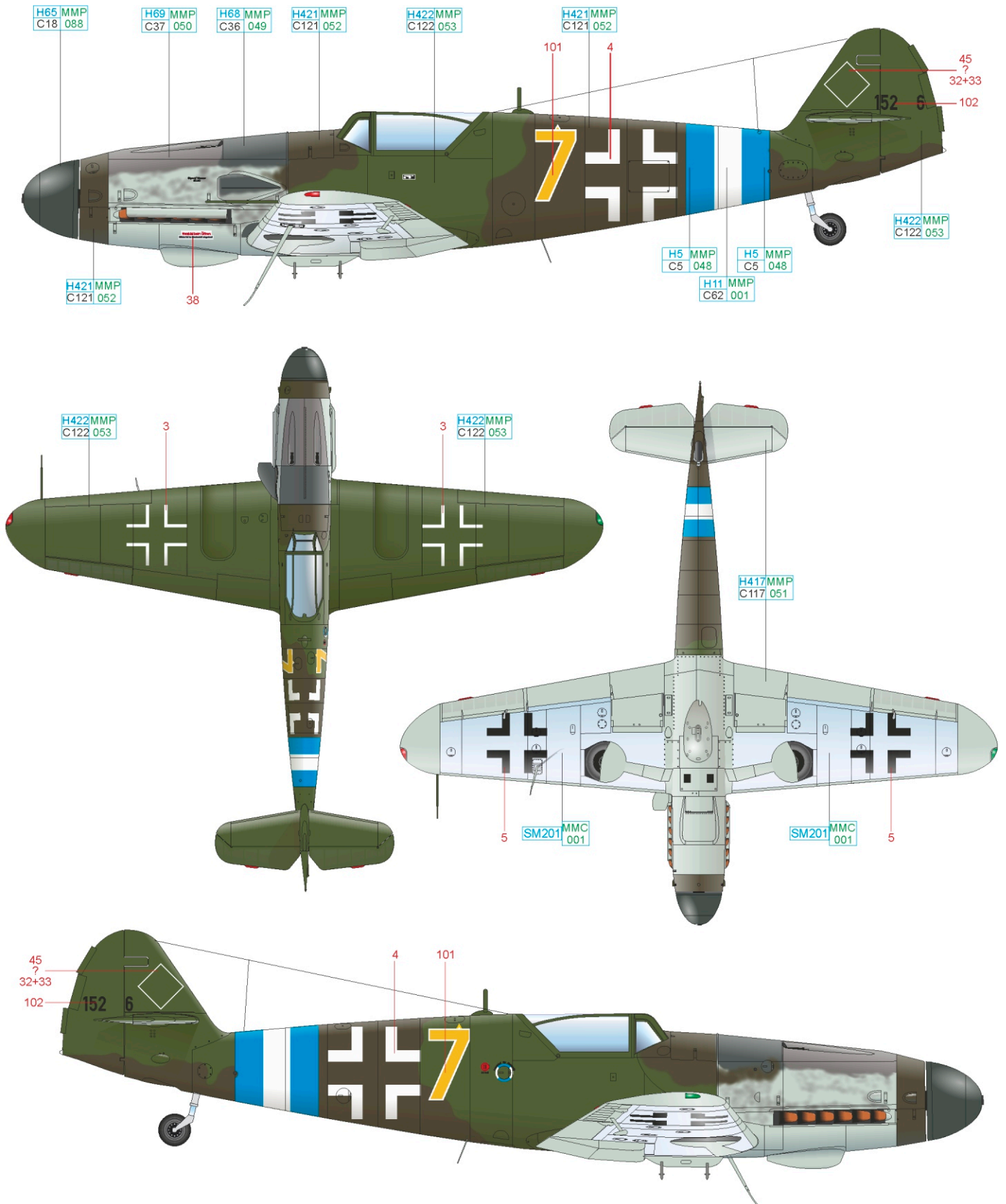

RLM 70	H65 MMP C18 088	WHITE	H11 MMP C62 001	BLUE	H5 MMP C5 048	SUPER FINE SILVER	SM201 MMC 001
RLM 82	H422 MMP C122 053	RLM 81	H421 MMP C121 052	RLM 75	H69 MMP C37 050	RLM 76	H417 MMP C117 051
					RLM 74	H68 MMP C36 049	