

# Westland Sea King Conversion Sets

RAF HAR.3/3a  
Royal Navy AEW.2  
Royal Navy HC.4  
Royal Navy HAS.6

## Sea King Details [common]

This section relates to the assembly and fitting of items included on the sheet marked 'Sea King Detail Set' that is included in your set. This is the fret included in our set Sea King Detail Set, that we sell as a separate item for US and Japanese modellers.

Most of the parts on this fret apply to any of the four UK versions of the Sea King, and include a highly-detailed entry-step assembly, connected to a section

of forward cabin floor, together with seats, partitioning, and other fittings, including parts to assist in the modelling of a Sea King with the tail section folded back. The kit is split in this way, but includes no detail.

## Assembly -

### Section A -

1. Fit windscreen wiper units [1 - handed] in place of kit parts B41 & B42. Fit the side window frames [2 -

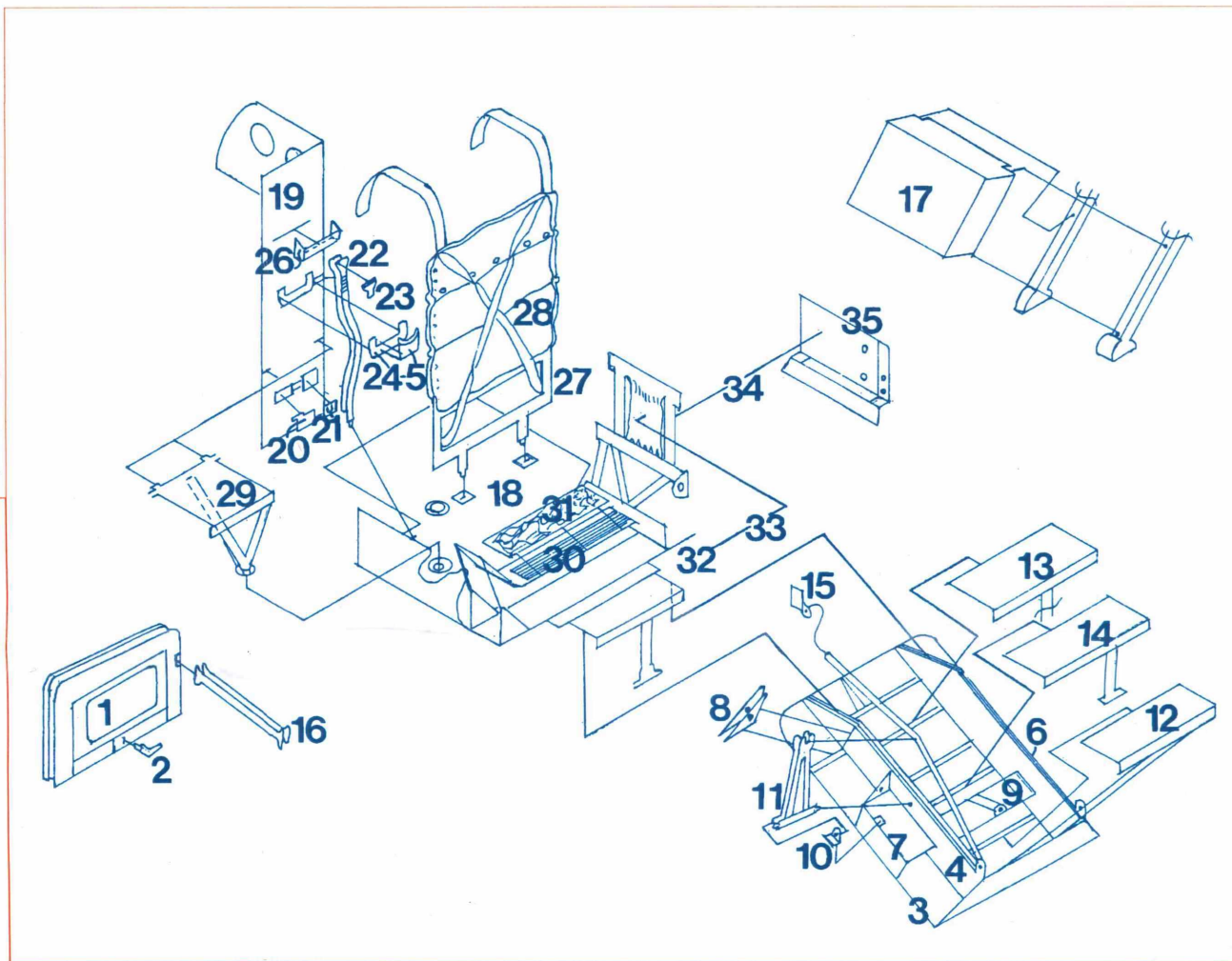
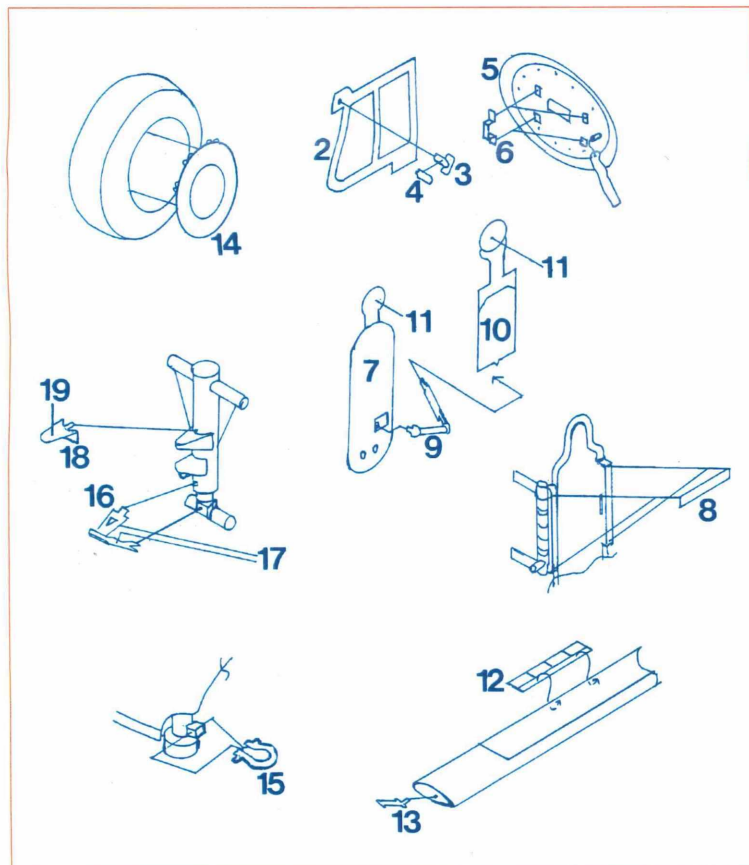

handed] as shown, adding mirrors [3 - handed], and 4. Discard kit parts B37 & B38.

2. Assemble FOD guards from parts 5 & 6, adding an RBF tag [included] onto a piece of fine wire fitted into holes in these parts. Note that the tags are at the rear of the FOD guards when fitted to the aircraft.

3. If you wish to assemble the kit with the tail section folded back, you should assemble and fit parts 7-9 + 1 x part 11 into the rear of the main fuselage halves, and parts 10 & 11 into the tail unit. Parts 12 should be fitted to the mid-outer trailing edges of the five main rotor blades [kit parts C14], and the five static dischargers [13] added to the tips of the blades, as shown.

4. Fit brake hubs [14] to the inside faces of the main wheels [kit parts C11], and assemble torque links from parts 16 & 17 - fitting these to main legs in place of kit parts C17. Assemble parts 18-9 as

shown, and fit to the front of the main legs. Laminate shackle rings from parts 15, and fit to rear wheel housing.

### Section B -

1. Carefully remove the two parts of the crew entry door from the port side fuselage, and clean up the edges. Fit part 1 to the inside face of the upper door section that you have removed. Fit part 2 into the slot in part 1. Set assembly aside.

2. Form and fit part 3 to the lower section of the door, and proceed with the assembly of the

complete entry step unit using parts 4-14 inclusive.

3. Form and fit part 18 to kit part B1, as shown, and form and add part 19, fixing this also to kit part B52. Add all details to part 19, using parts 20-26 inclusive. Laminate parts 27 & 28 and fit into slots in part 18. Form and add seat [29] into slots in parts 18 & 19.

4. Laminate parts 32 & 33 and fit to the front face of the relevant section of part 18, adding part 34 to the rear. Form and add part 35 to the bottom rear of part 34. Fit part 30 to the outer edge of part 18, adding the non-slip overlay [31] if this is fitted on the version you are modelling [this detail varies considerably]. Form and fit part 17 to the rear of the LH side cockpit seat supports [kit parts C31 & C32].

5. Join the entry step assembly to part 18, as shown, and fit the two small brackets [15] to the sides of the door opening in the fuselage side. Add grab rails from fine twine [that used in model boat rigging is ideal]. Finally, the upper door unit dealt with in paragraph 1 of this section, can be fitted by use of the strut [laminated from parts 16].

*Westland Sea King Details*

The next section of these instructions apply to all of the four Sea King UK Variant Conversion Sets produced by Flightpath, and refers to all parts used on two or more versions of the Royal Navy Variants, and to ALL parts relevant to the RAF HAR.3 version. You should note that the same parts may be in different positions from variant to variant, but this is clearly marked on the drawings.

Supplementary sections relating to the three Royal Navy versions and to the new RAF HAR.3a variant are included where relevant, and cover those etched parts on the additional fret for that version, and the castings that relate to it.

*Note - parts are applicable to all UK versions unless otherwise stated.*

**Assembly -**

1. Fit strake to upper port fuselage using parts 1 & 2. Fit cover [3] over sonar cut-out in kit part B59 if relevant.

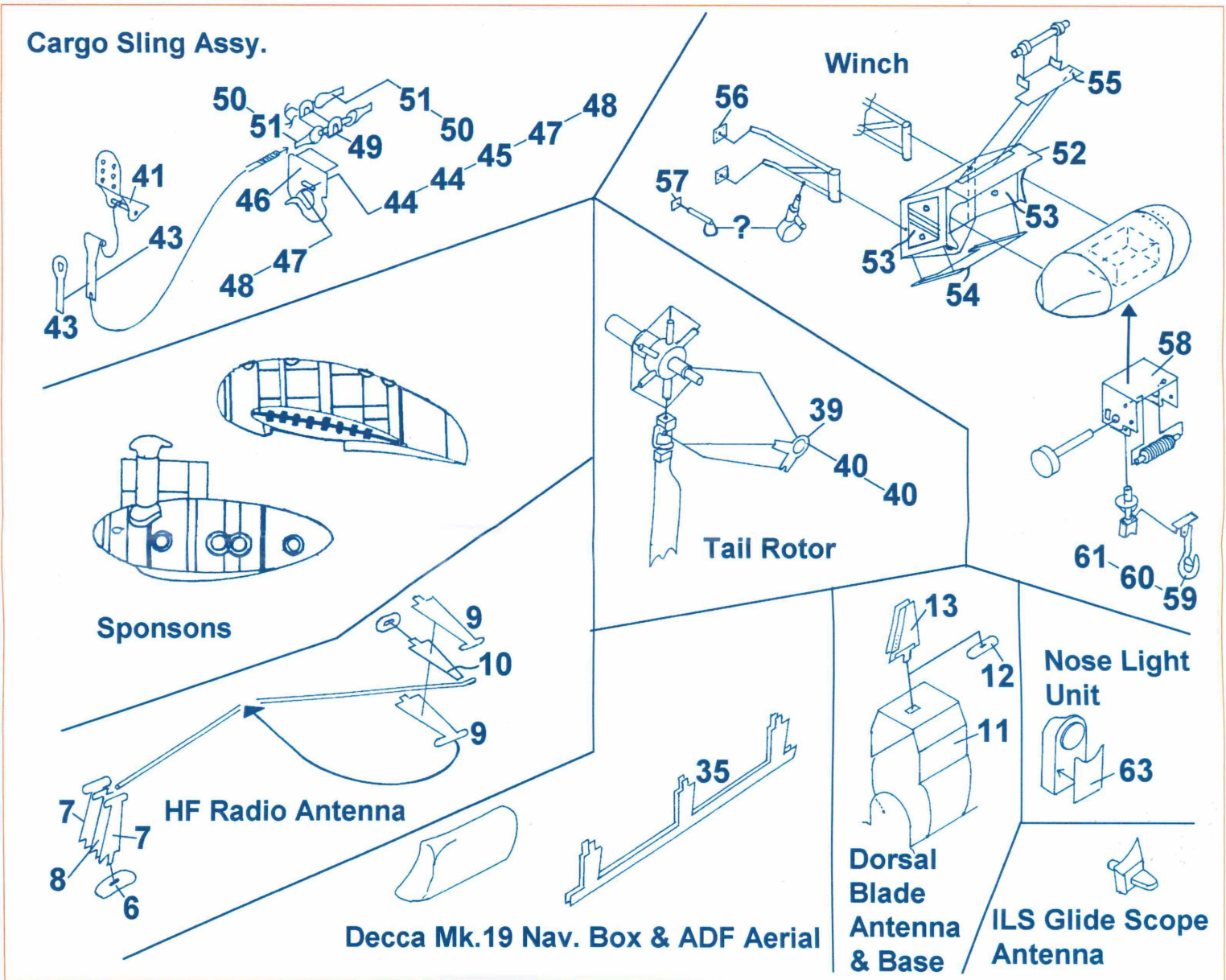

2. The sponsons in the kit are simply fitted in place of the kit items to versions HAR.3/3a, AEW.2 and HAS.6. In the latter case, however, you may wish to modify the rear of the starboard resin sponson by removing the section aft of the wheel bay, and fitting

the kit MAD boom.

similar.

3. Fit antenna assembly to top of port sponson [not HAR.3a or HC.4] and to mid and rear of port fuselage by use of parts 6-10 and fine fuse wire or you are modelling]

spine or the underside of the aircraft. This will use selected castings from those supplied and a selection of etchings, as shown.

5. Parts 36 & 37 fit to the resin spine radome on

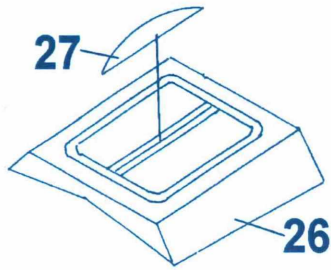

Decca 71 Doppler Radar Unit - ventrally mounted behind AC Beacon

Honeywell AN/APN 198 Radar Altimeter Units - two under nose [handed]

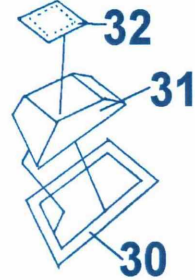

I Band Transponder - these have now been removed from 'Grey Whale' HAR.3s, but are present on all other UK variants.



AEW.2 & HAS.6 - underside



Underside UHF/VHF Radio Antenna - shown inverted



Royal Navy Wheel Chock

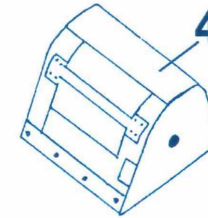

Underside IFF Fairing - shown inverted

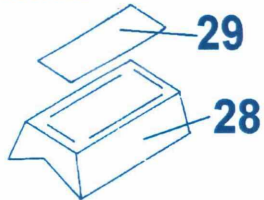

Twin Chelton UHF Homing Antennas - under nose - make blades from wire

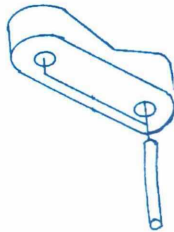

VHF [AM] Homers - under nose - 2 units [handed]



Omega Antenna Box - port underside of tail



Aft RWR Fairing - 'Grey Whale' HAR.3s only

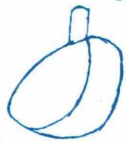

Fairing - under port side cockpit window

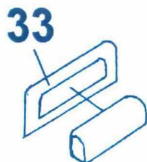

Nose-mounted RWR Fairing - 'Grey Whale' HAR.3s only



centrally under port side nose window

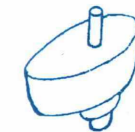

Ventral Anti-collision Beacon

Ventral Sonar Housing Cover Plate - shown inverted



Grill - port side engine cowling



14



15



16

Aerials - various positions on different versions - see instructions



Underside VHF [FM] Radio Antenna - shown inverted

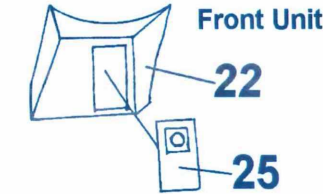

Front Unit

22

25

'Orange Crop' Fairings - fitted to Royal Navy AEW.2 & HAS.6 variants

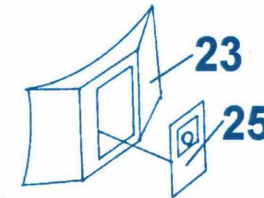

23

25

Rear Upper Unit

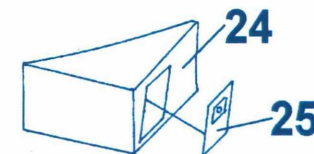

24

25

Rear Lower Unit

marks AEW.2 & HAR.3/3a and the larger version on the HAS.6 - see sketches. Part 38 should be added to the lower front of kit part B45.

6. Laminate parts 39 and 40 [2 off], and assemble these, and the casting supplied, to form the replacement six-bladed tail rotor unit present on all UK Sea Kings. Fit in place of the parts in the kit.

7. Parts 41-51 assemble as shown, into the cargo hoist as fitted to HAR.3/3a & HC.4 variants - although some members of both these marks have the heavier duty hoist fitted - check your references. The assembly should be installed using coarse thread [or model boat rigging] to represent the hoist cables.

8. Assemble the replacement winch unit from parts 52-61 and the castings supplied, and fit in place of the kit version. Note that the light unit on most Royal Navy machines is of the style that fits into the fuselage via part 57, rather than the version fitted to the hoist frame - as on HAR.3/3a machines.

9. Part 62 is a plate to assist you in blanking off the one window required to be filled in as part of the conversion to a UK aircraft. Parts 5 are frames for the rear



Strake - from parts 1 & 2

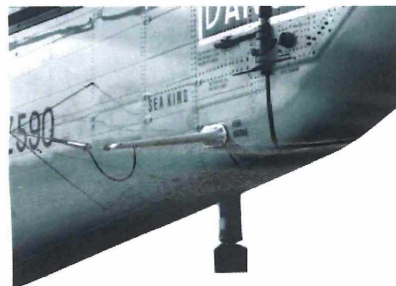

Sea King HAR.3 Photographs

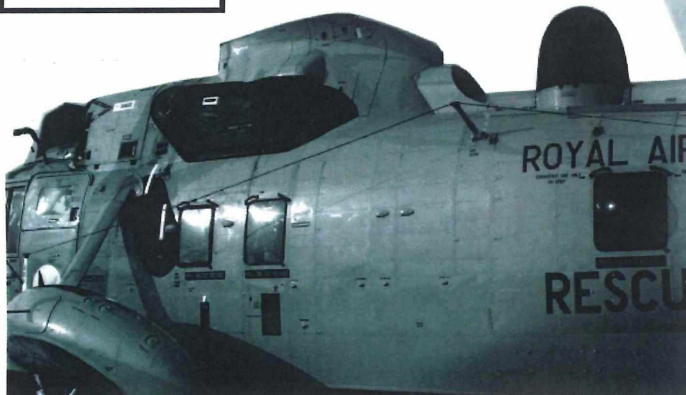

New route of aerial wire - to link with etched parts 9 & 10 from 'Common Parts' fret above window

**HAR.3a Only**

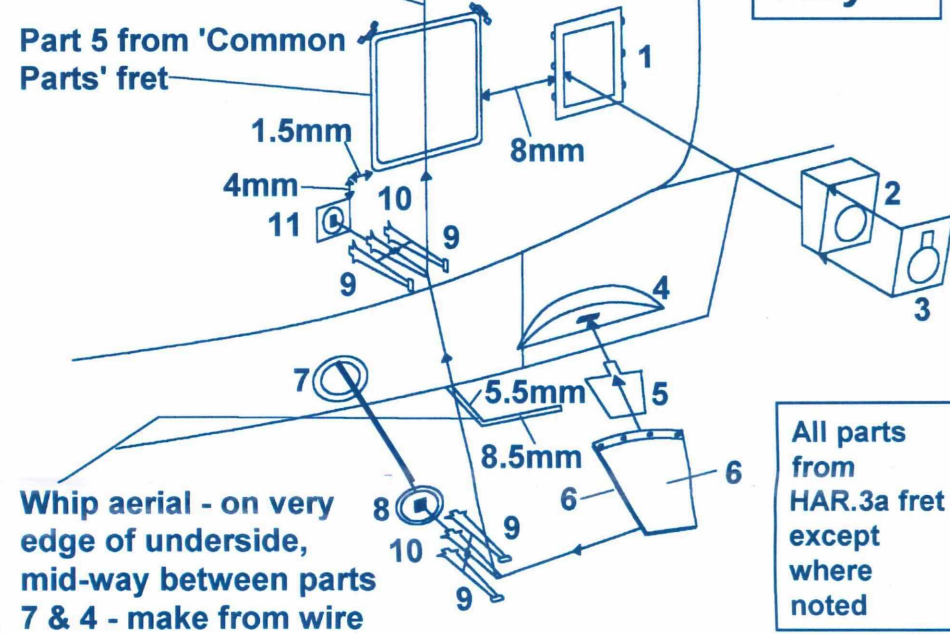

domed window transparencies supplied with the HAR.3/3a, HC.4 and HAS.6 sets. In the latter case, these are included in case you wish to build your model as an HAS.5 SAR version. Note that these windows are square in proportion and not rectangular as in the rear windows impressed on the inside of the kit fuselage halves. The remaining window relevant to UK Sea Kings is also impressed on the inside of the port fuselage moulding.

window and centrally to the window horizontally. Add light unit [2], and front panel [3].

10. Finally - parts 64 are Royal Navy wheel chocks which can be formed as shown, and used in the display of your RN Sea King. Remember that Flightpath produce an RAF Diorama Set including wheel chocks, a fire extinguisher and a tow-bar, ideal for use with the Sea King, plus a kit for the 25kva Ground Power Unit - invariably seen beside all parked HAR.3/3a aircraft.

2. Construct blade antenna from base [4] and parts 5 and 2 x 6. Parts 6 should be curved slightly as shown, so that they slip over part 5 when fitted back-to-back. This assembly should be fitted where indicated relative to the kit panel line.

3. Fit the mast assembly for the HF radio antenna using parts 2 x 9, 10 and 11, positioned where shown in relation to the bubble window. The lower mast should then be fitted using parts 7, 8, 2 x 9 and 10, on the same vertical datum as the mast above it. The sponson mast fitted to the HAR.3 is deleted and the antenna line is routed down from the upper central mast, through these two new masts, and back to parts 6, as shown.

HAR.3a Version Only -  
1. Fit backplate for light [1] 8mm aft of port bubble

4. Finally, you should shape a whip aerial from wire to the sizes given, and fit where shown on the

extreme port edge of the hull bottom.

**AEW. 2 Version Only -**

1. Fit parts 1-5 to the front of the resin- moulded radome bag as shown. Fit parts 6 and 7 to the top of the radome front plate and parts 8 & 9 around the perimeter, as indicated. Fit cast pivoting arm into the front of the radome.

2. Use the template marked 'x' to cut out a hole in the lower left hand corner of the cabin door in the starboard fuselage side, and fit part 10 to the raised section of the door. Part 11 fits over the cut-out made using 'x' and this and part 10 then form the locating hole for fixing the radome unit to the fuselage, as shown.

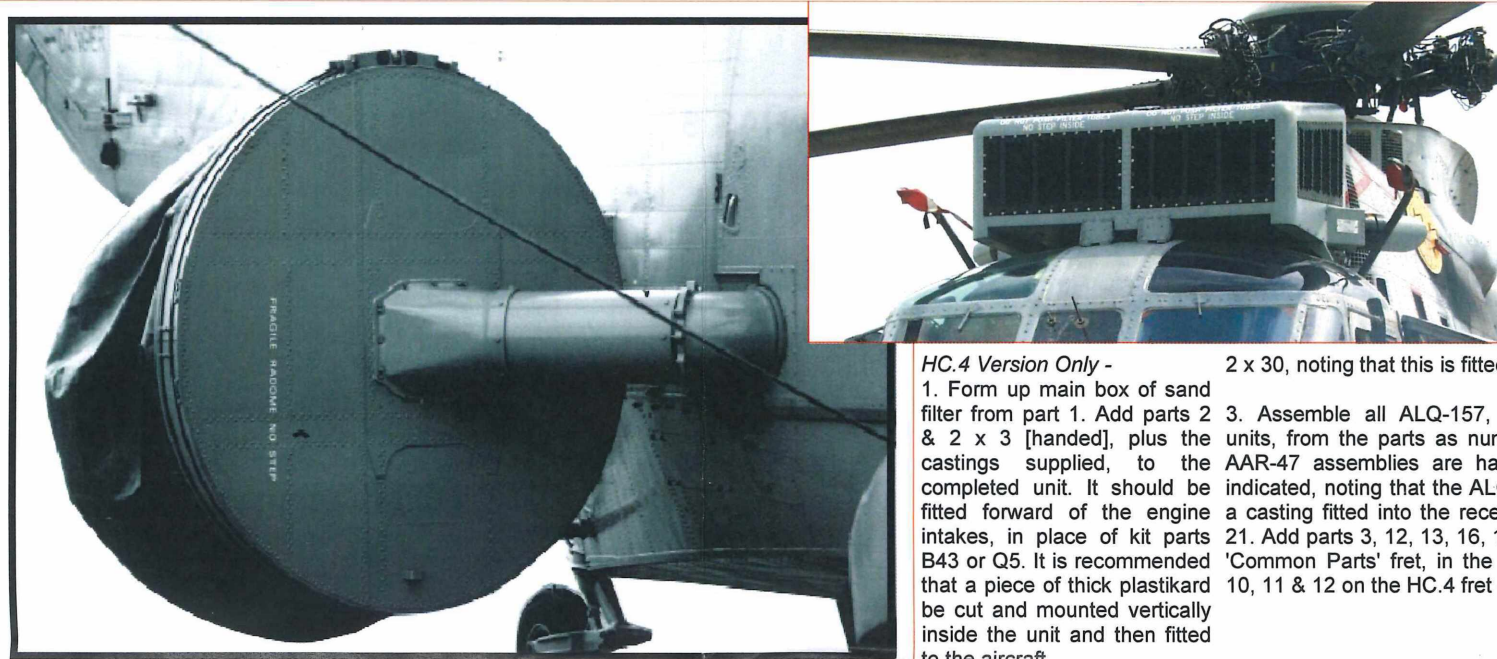

2. Form GPS fairing from part 9 and fit over the spine of the aircraft as shown. Assemble the 'Commando' Step from parts 4-8, as shown, and fit under cabin door of starboard fuselage side. Add V/TAC ARC 340 Aerial from parts 28x2 & 29, and Broad band VHF aerial from

**HC.4 Version Only -**

1. Form up main box of sand filter from part 1. Add parts 2 & 2 x 3 [handed], plus the castings supplied, to the AAR-47 assemblies are handed. Fit all these as completed unit. It should be fitted forward of the engine intakes, in place of kit parts B43 or Q5. It is recommended 'Common Parts' fret, in the positions shown. Parts that a piece of thick plastikard be cut and mounted vertically inside the unit and then fitted to the aircraft.

2 x 30, noting that this is fitted to starboard.

3. Assemble all ALQ-157, AAR-47 & Prophet II units, from the parts as numbered, noting that the units, from the parts as numbered, noting that the ALQ-157 assemblies have a casting fitted into the recesses provided on parts 10, 11 & 12 on the HC.4 fret complement those

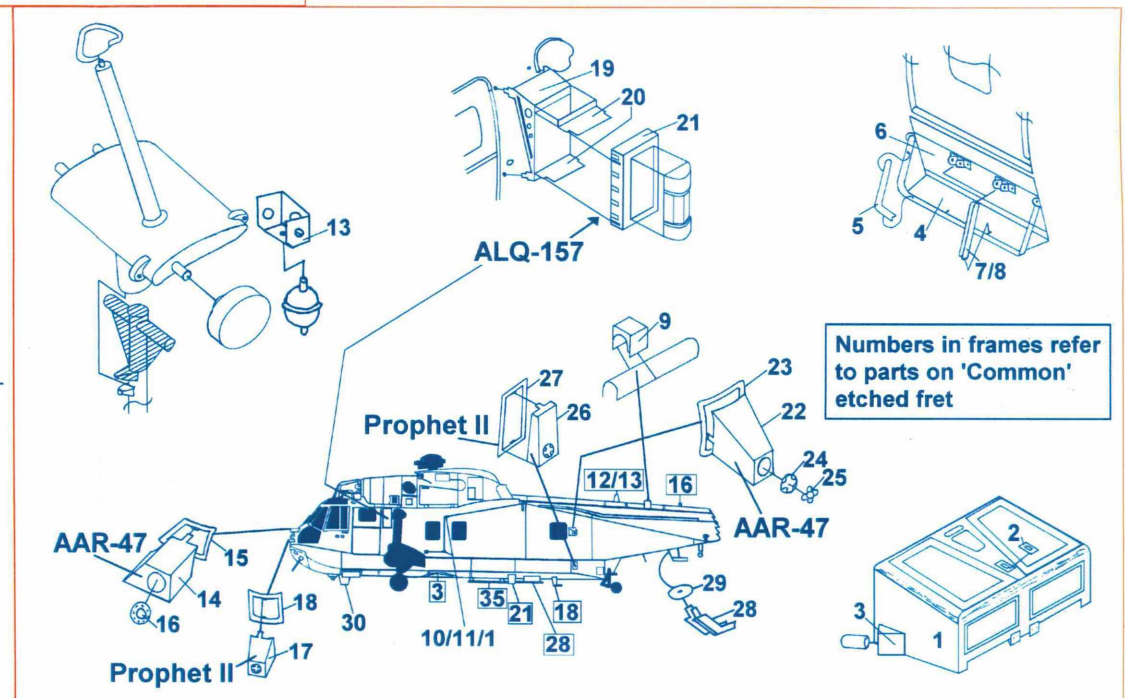
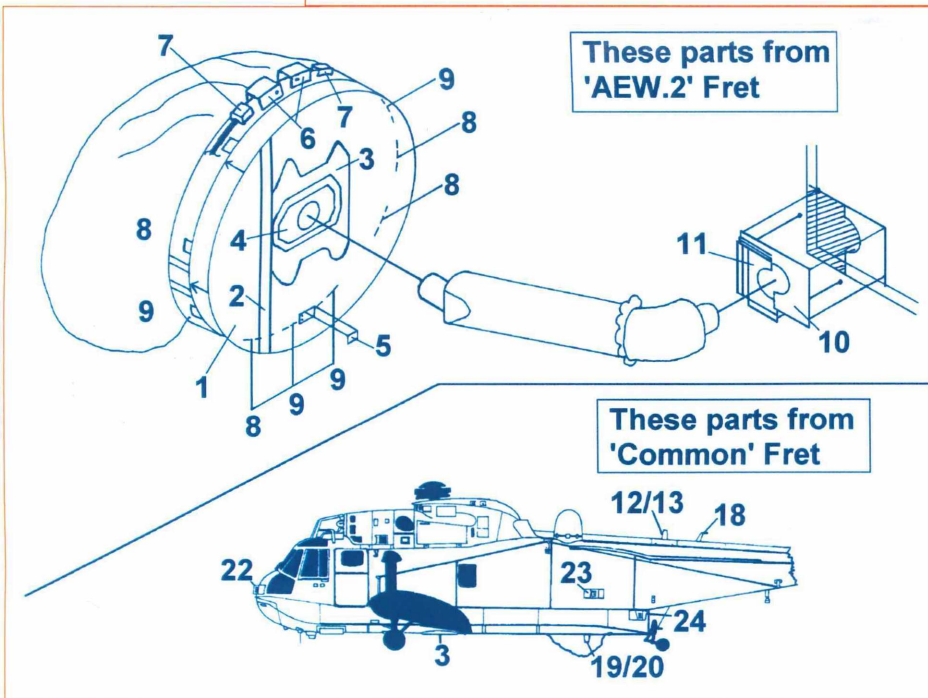

Sea King HAS.6  
Photographs

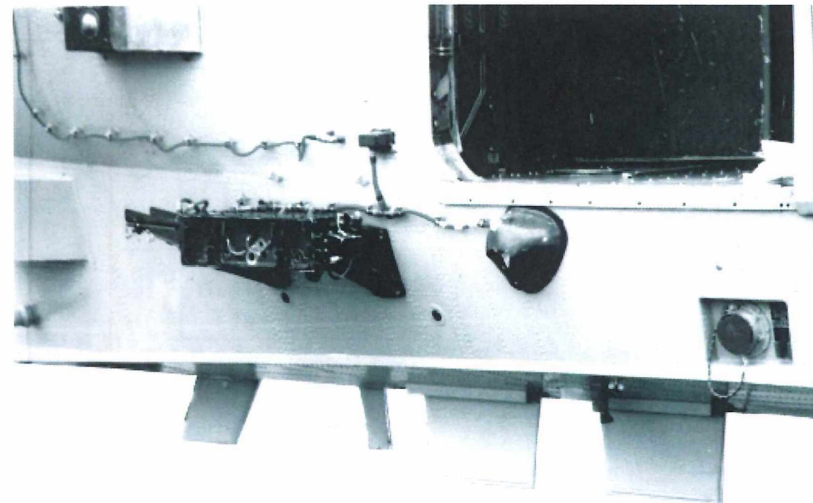
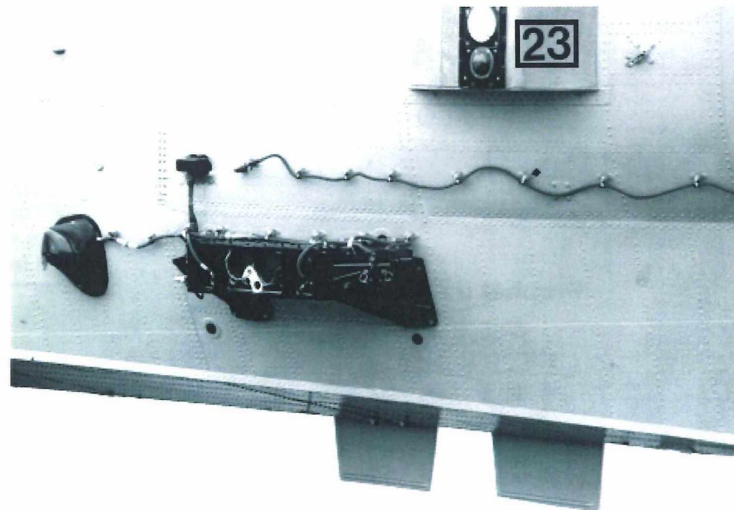
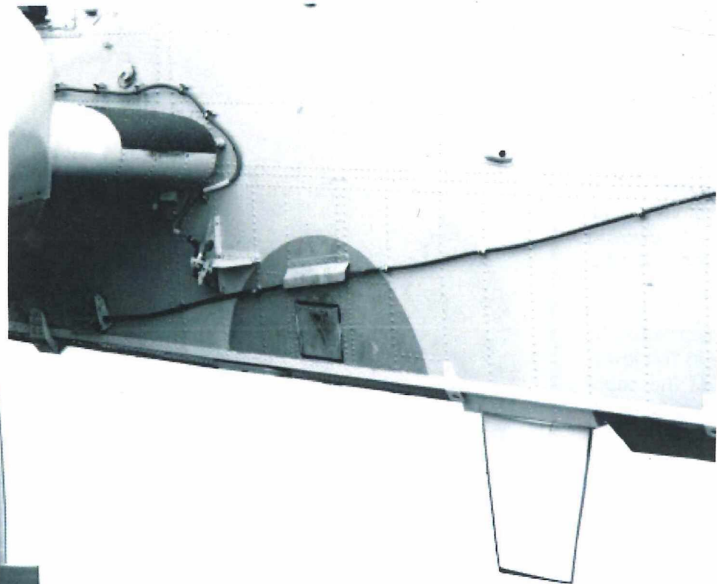

**Numbers in frames refer to parts on 'Common' etched fret**

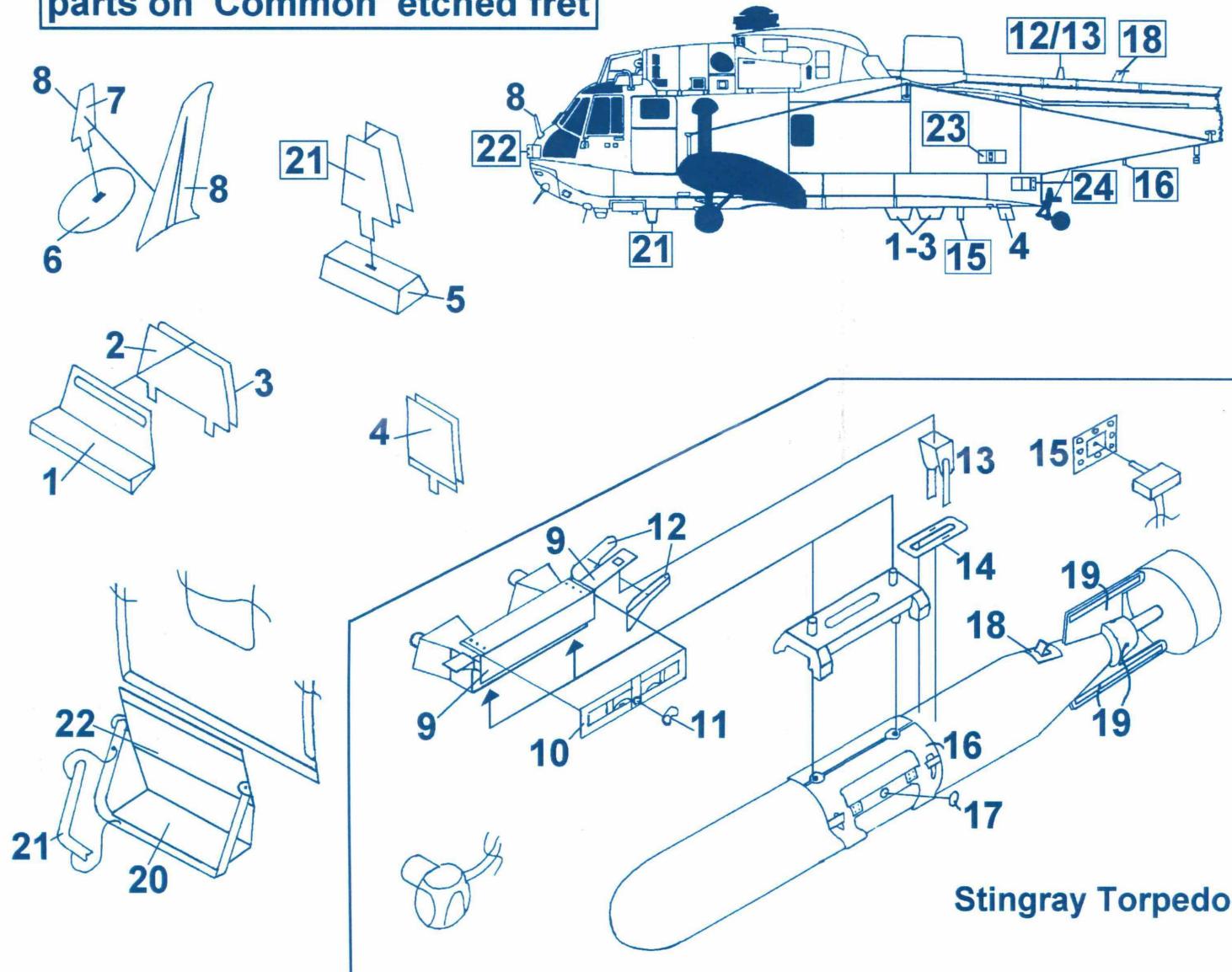

provided on the common fret, and are needed to complete the longer and more complicated HF aerial string found on the HC.4. The route of this is shown on the sketch provided.

4. Fit the replacement resin sponsons, and cast struts and flotation bags, adding the kit undercarriage legs - modified as shown. Fit the flotation gear bottle castings on to the etched brackets [parts 13 - handed]. These fit under each sponson, as shown.

*HAS.6 Version Only -*

1. Construct 2 antennae from parts 1-3 and fit to rear of kit part B59 as shown, together with aerial laminated from parts 4. Part 5 is a base for the aerial made from parts 21 on the 'Common Parts' fret, and is fitted to the front starboard side of B59. Assemble aerial from parts 6-8 and fit to port side of aircraft nose.

2. Assemble a handed pair of torpedo pylons from the castings supplied and parts 9-15. The fitting of these is a mirror image on the other side of the aircraft.

3. Assemble 2 x Stingray torpedoes using the castings supplied, and parts 16-19. The completed units should be fitted to the pylons.

4. Assemble cabin door step from parts 20, 21 and 22 as shown, and fit under the cabin door, in line with the rear edge of the door frame. These are now fitted to those aircraft assigned to the Search and Rescue role, but may also be fitted to some of the Sub-Hunters.