

NÁVOD / INSTRUCTION

SH72143 Fulmar Mk.I

CZ

HISTORIE

Fulmar byl navržen s ohledem na Specifikace O.8/38 požadující dvojmístný námořní obranný stíhací letoun. Jelikož se nepředpokládalo, že by se setkal se stíhačkami protivníka, nebyly brány ohledy na vysoký výkon ani obratnost, ale na dolet a těžkou výzbroj. Dále byl také brán zřetel na navigátora / radistu, který byl nepostradatelný při dlouhých letech nad mořem. Prototyp Fulmaru byl velmi aerodynamicky čistý a měl již skládací křídla. Prototyp K5099 poprvé vzletl 13. ledna 1937 z letiště Ringway. Stroj byl pilotován zkušeným pilotem firmy Fairey Chrisem Stanilandem. Po prvních testech byl překonstruován ocas, jehož výška se zvětšila o 20,3 cm.

V roce 1940 byla 806. Squadron FAA, operující letadlové lodi HMS Illustrious, jako první vybavena Fulmary. Fulmar nebyl velkým soupeřem pro pozemní stíhačky. Poprvé se zúčastnil bojových akcí během ochrany konvojů zásobující Maltu v říjnu 1940. Houževnaté Fulmary byly schopny postavit se i o mnoho agilnějším italským a německým protivníkům. Na podzim, během útoku na Taranto, když poskytovaly krytí Swordfishům si připsaly konto 10 sestřelených bombardérů a 6 stíhaček. Od roku 1942 začaly být Fulmary nahrazovány jednomístnými stíhačkami jako Supermarine Seafire nebo Grumman Martlet. Dále také sloužily jako noční eskorty konvojů a cvičné letouny na přeškolení na letoun Fairey Barracuda.

Technická data:

Délka: 12,29 m, rozpětí: 14,02 m, výška: 3,54 m, prázdná váha: 3960 kg, max. rychlost: 438 km/h ve 2200 m, dolet: 1340 km, dostup: 4880 m, výzbroj: 8 x 7,7mm kulomet Browning v křídle a 1 pohyblivý 7,7 mm kulomet Vickers K, 2 x 100 lb (45 kg) nebo 250 lb (110 kg) pumy.

GB

HISTORY

The Fulmar was submitted to meet Specification O.8/38 for a two-crew fleet defence fighter. As it was not expected to encounter fighter opposition, high performance or manoeuvrability was not considered important, but long range and heavy armament were, with the provision of a navigator/wireless operator considered essential for the long, over-ocean flights would be required. The Fulmar prototype was aerodynamically clean and featured a folding-wing. The prototype K5099 first flew on 13 January 1937 at Ringway with Fairey Test Pilot Chris Staniland at the controls. After the first flight tests, the tail was revised, being raised eight inches (20.3 cm). The first squadron to be equipped with the Fulmar was No. 806 Squadron FAA in July 1940 operating from HMS Illustrious. The Fulmar was not well matched with land-based fighters. First seeing action on Malta convoy protection patrols in September 1940, the sturdy Fulmar was able to achieve victories against its far more agile Italian and German adversaries. By the fall, Fulmars had shot down ten Italian bombers and six enemy fighters, while giving top cover to the Swordfish raid on Taranto. By 1942, the Fulmar was being replaced by single-seat aircraft such as the Supermarine Seafire or by Grumman Martlet. It saw useful service in night time roles as a convoy escort and was used to train crews for the Fairey Barracuda.

Technical Data:

Length: 40 ft 4 in (12.29 m), Wingspan: 46 ft (14.02 m), Height: 11 ft 7 in (3.54 m), Empty weight: 8,720 lb (3,960 kg), Maximum speed: 272 mph at 7,250 ft (438 km/h at 2,200 m), Range: 830 miles (1,340 km), Service ceiling: 16,000 ft (4,880 m), Armament: 8 fixed 0.303 in Browning machine guns, and 1 flexible mounted 0.303 Vickers K machine gun., 2 x 100 lb (45 kg) or 250 lb (110 kg) bombs.

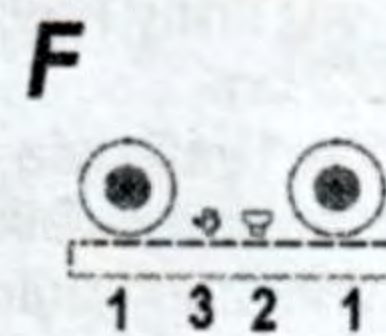
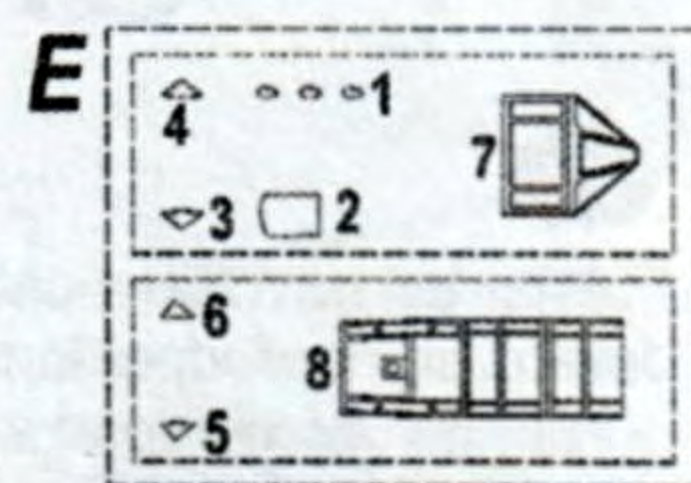
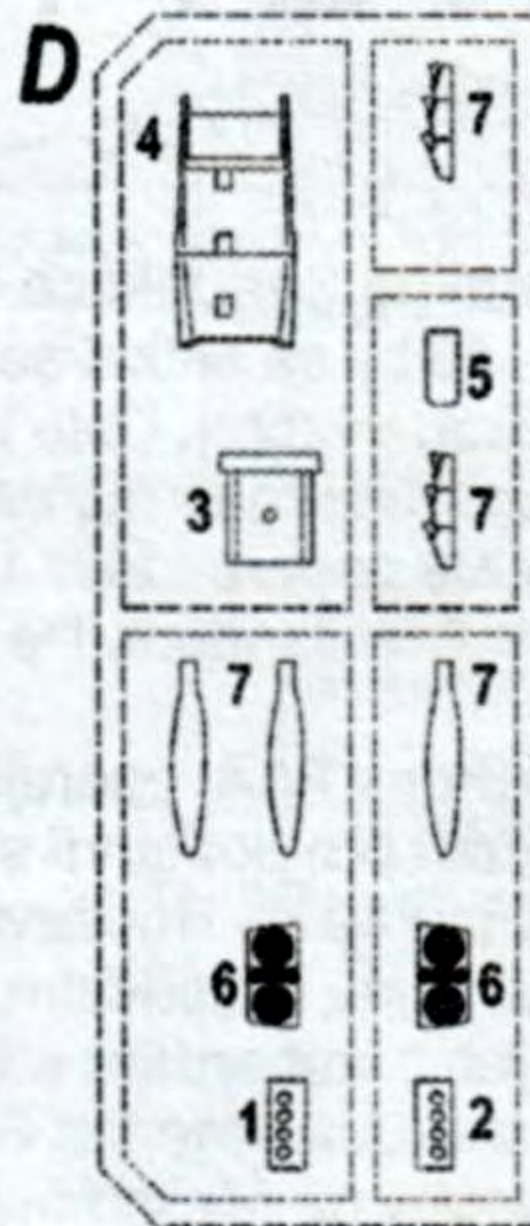
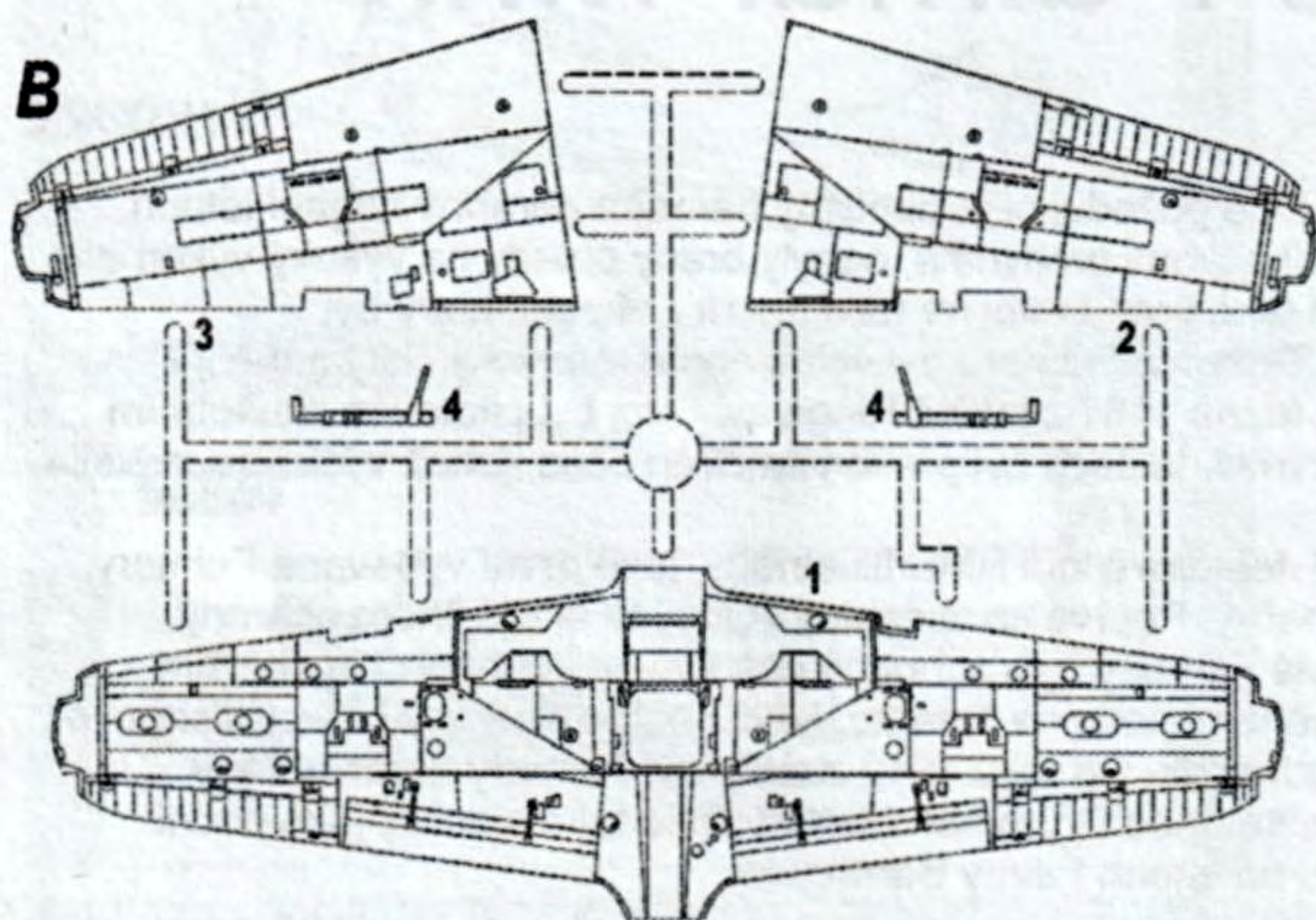
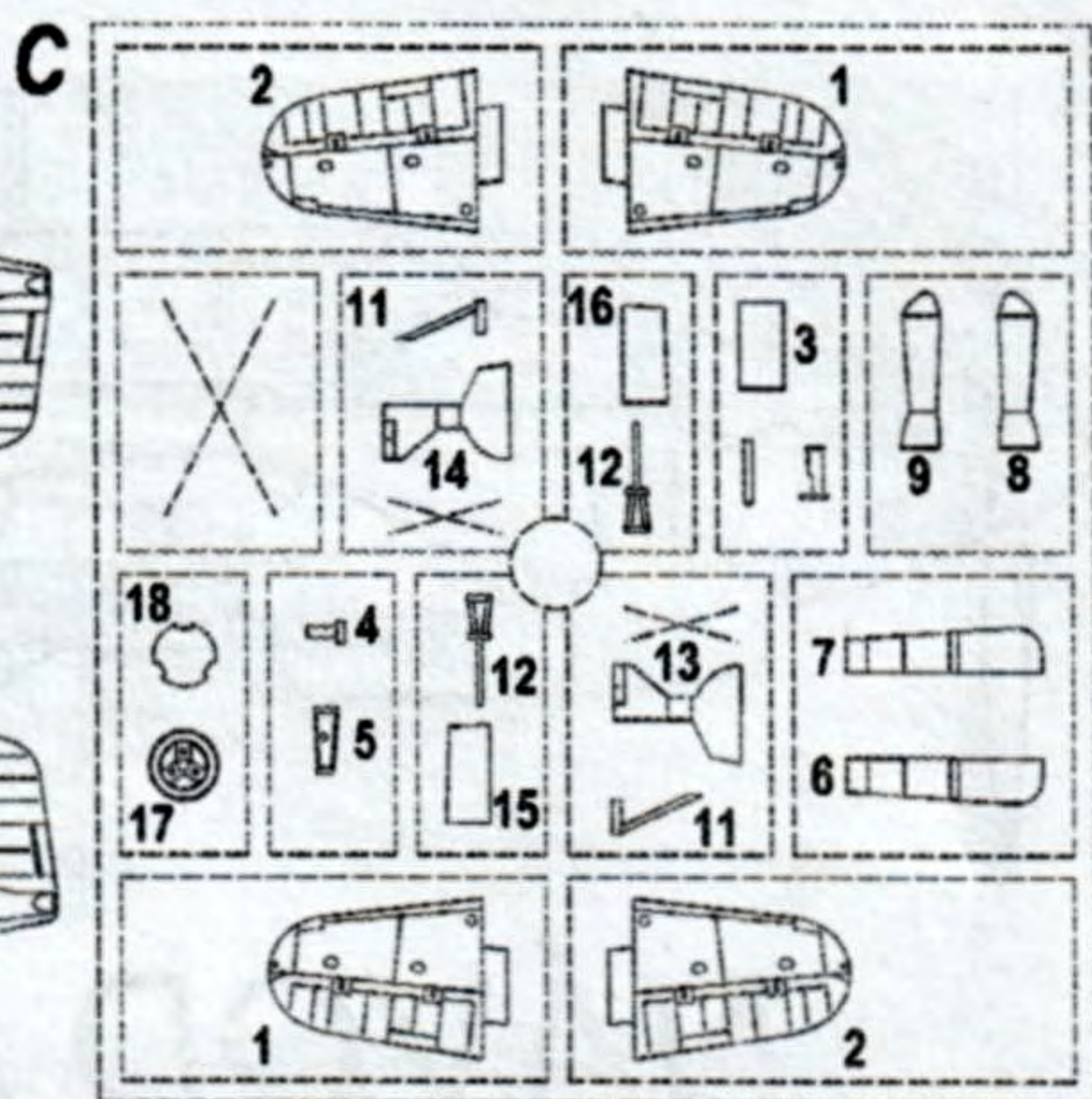
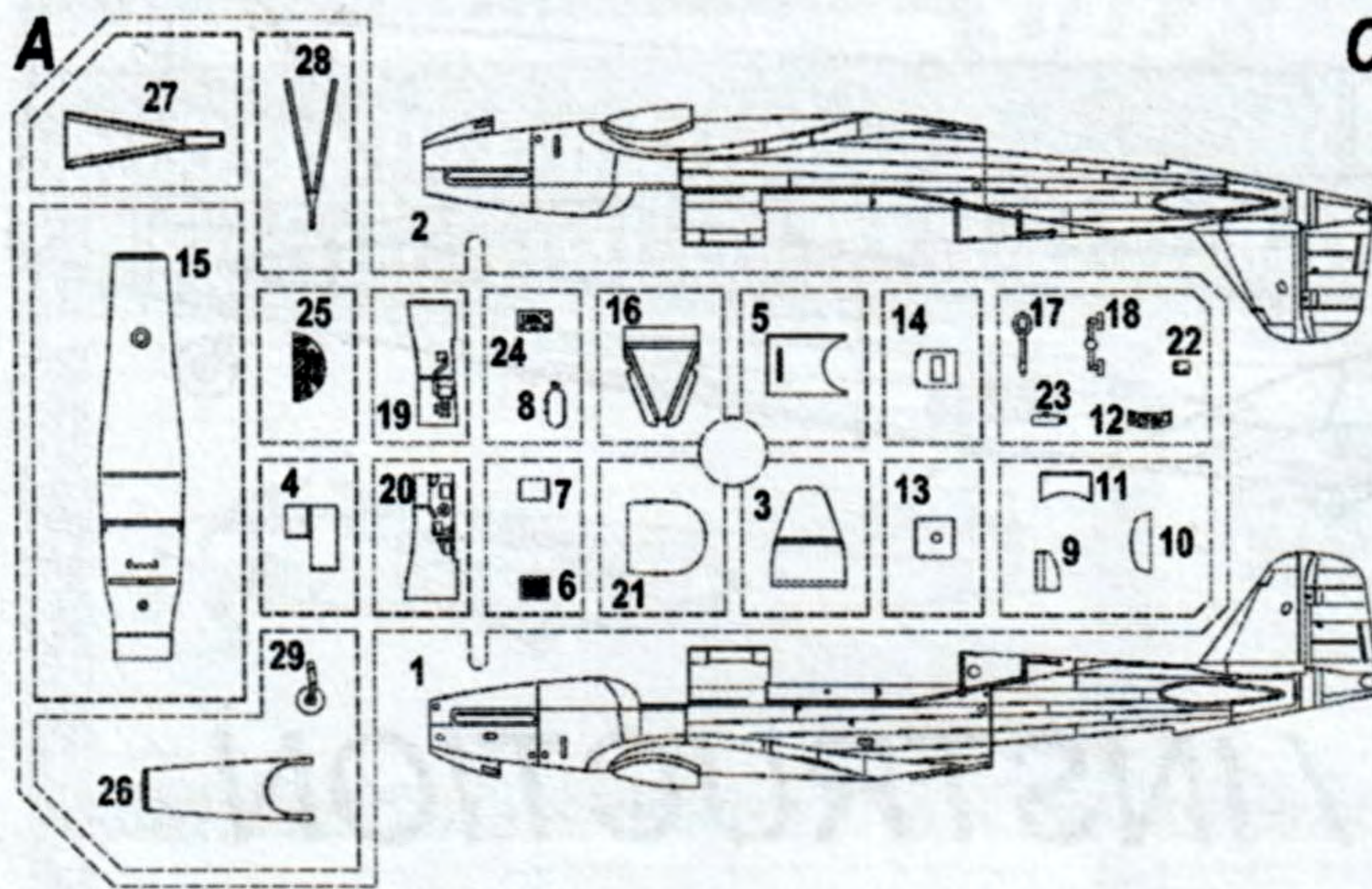

H2 / C2	Gloss Black / Lesklá černá
H12 / C33	Matt Black / Matná černá
H18 / C28	Steel / Ocel
H27 / C44	Tan / Plátno
H32 / C40	Field Grey / Polní šedá
H76 / C61	Burnt Iron / Opálený kov
H77 / C137	Tire Black / Černá na pneumatiky
H78 / C38	Olive Drab / Nevýrazná olivová
H325 / C325	Sky Grey / Nebeská šedá
H333/C333	Extra Dark Sea Grey / Extra tm. mořská šedá
C364	Grey Green / Šedozelená
C368	Sky / Nebeská



PHOTOETCHED PARTS (PP)

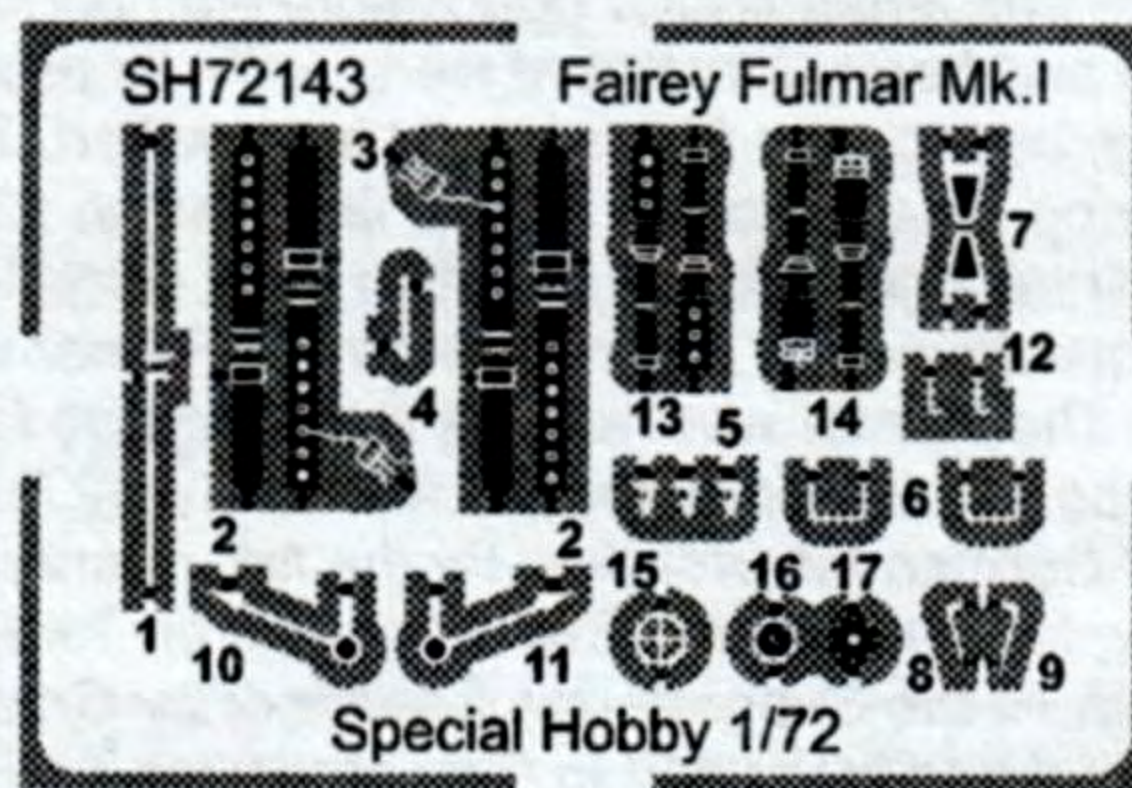

Možnost volby
Optional
Nach belieben
Option

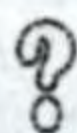

Oddělit
Cut with knife
Mit Messer schneiden
Couper au couteau

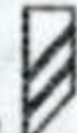

Ohnout
Bend
Biegen
Courber



Lepidlo na kov
Glue for metal
Metallkleber
Colle a metal



1

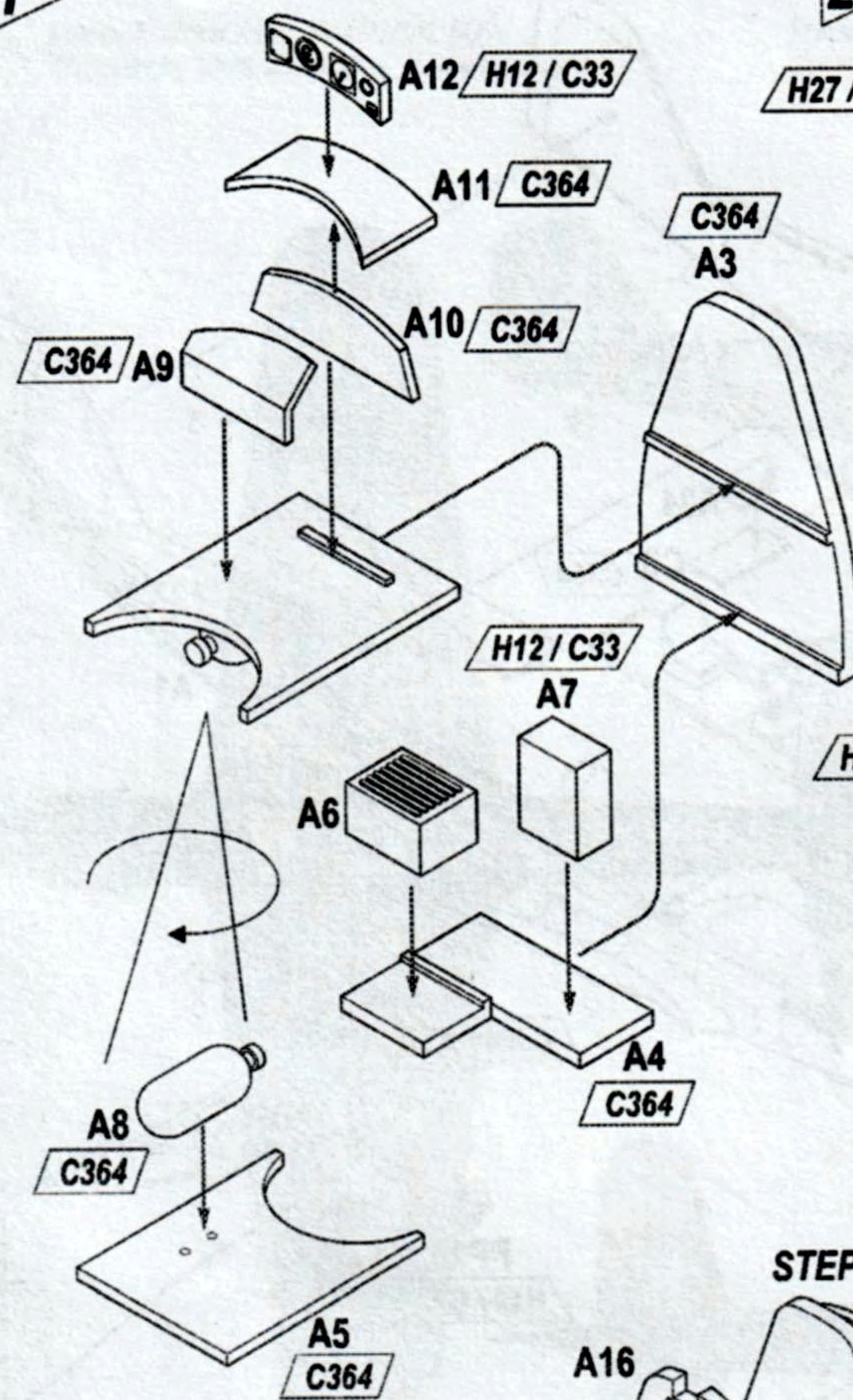

2

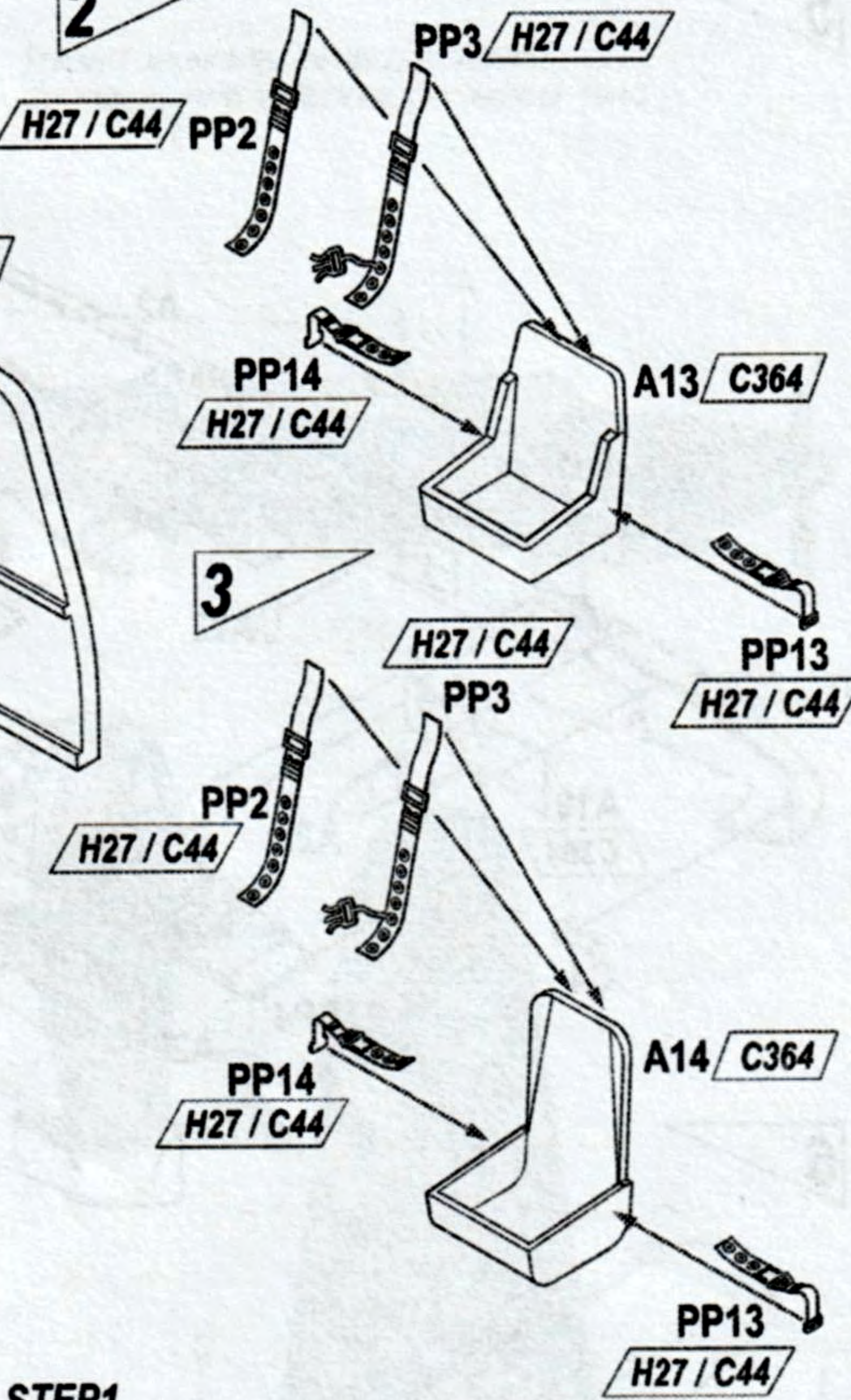

3

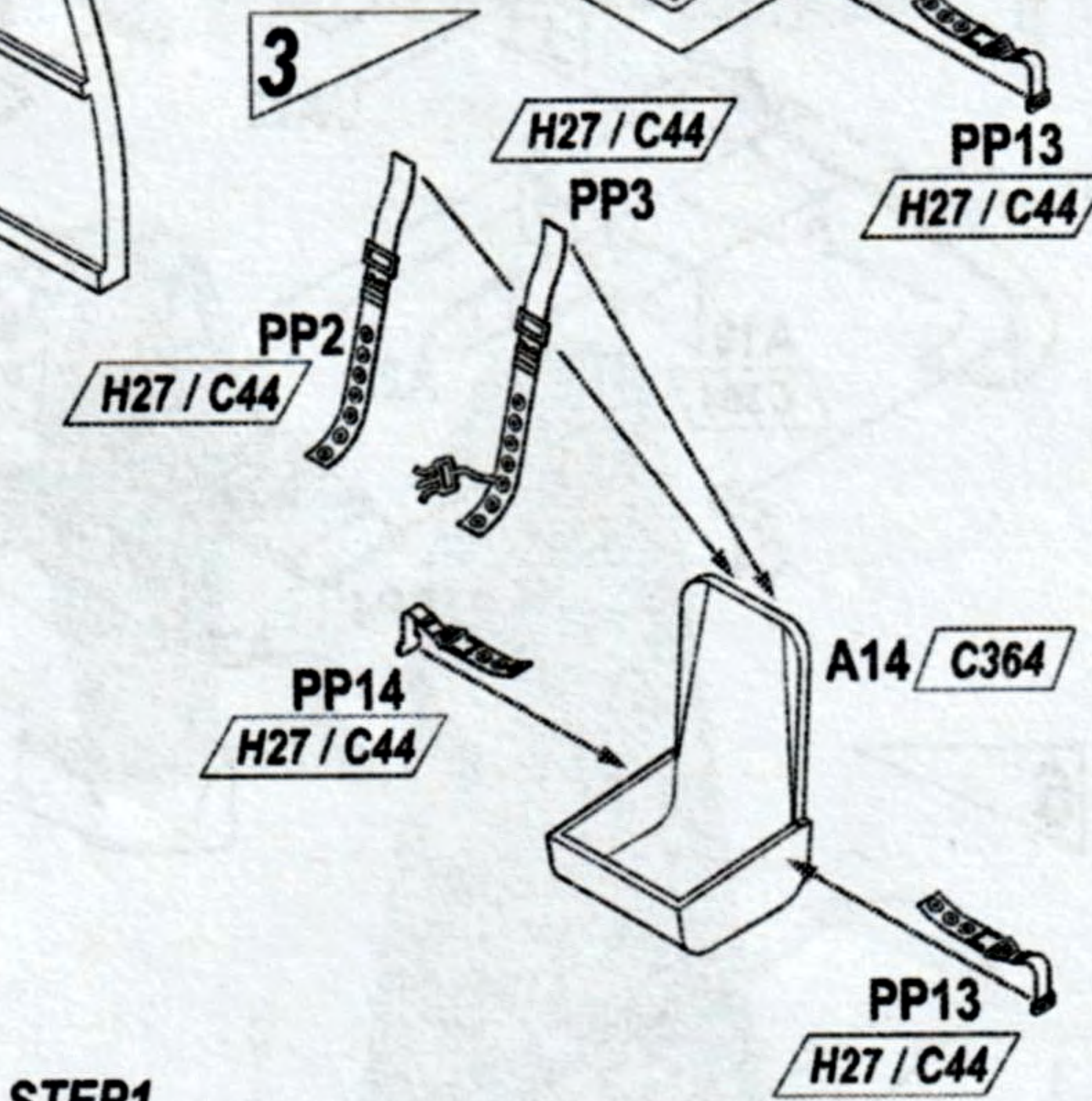

4

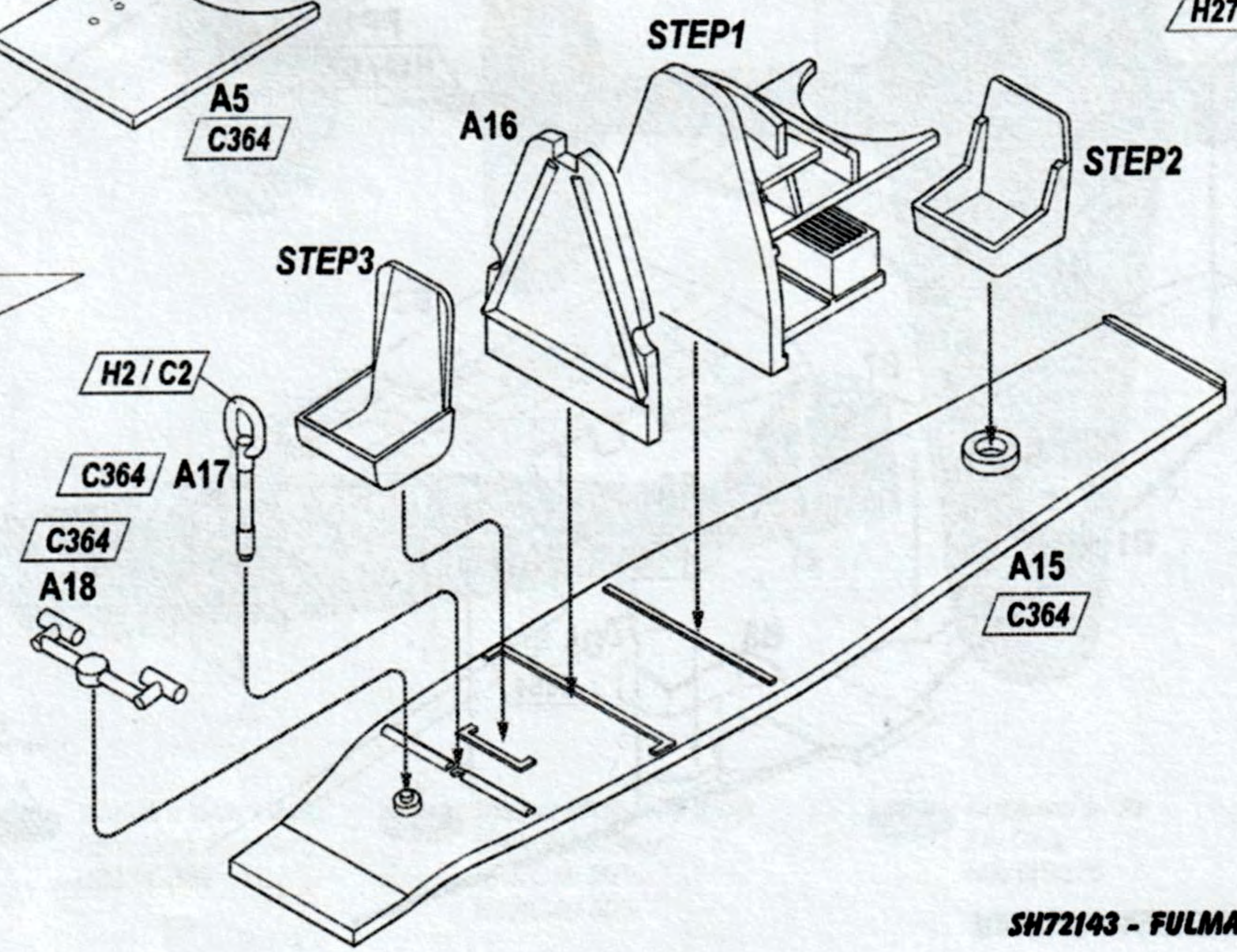

5

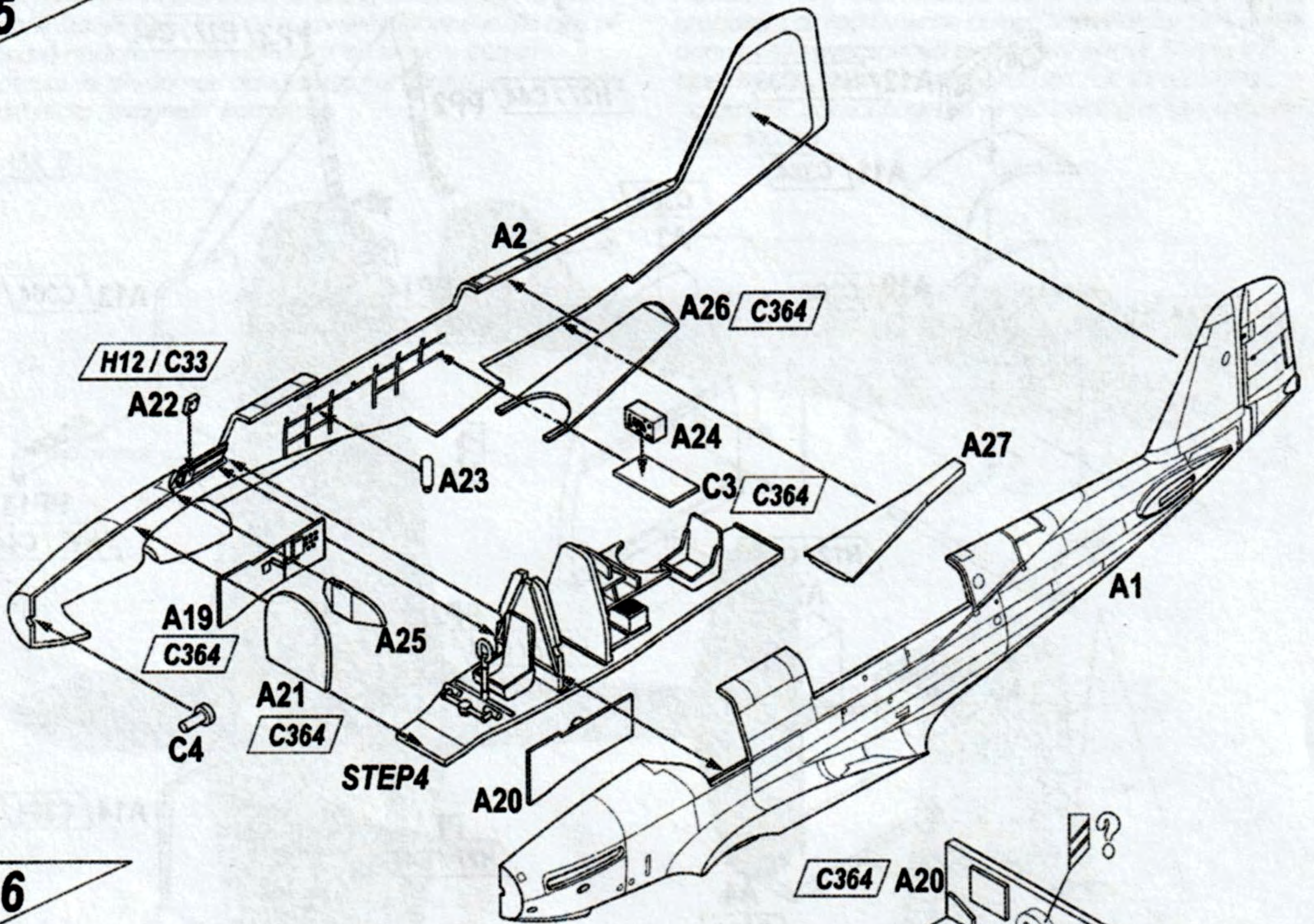

6

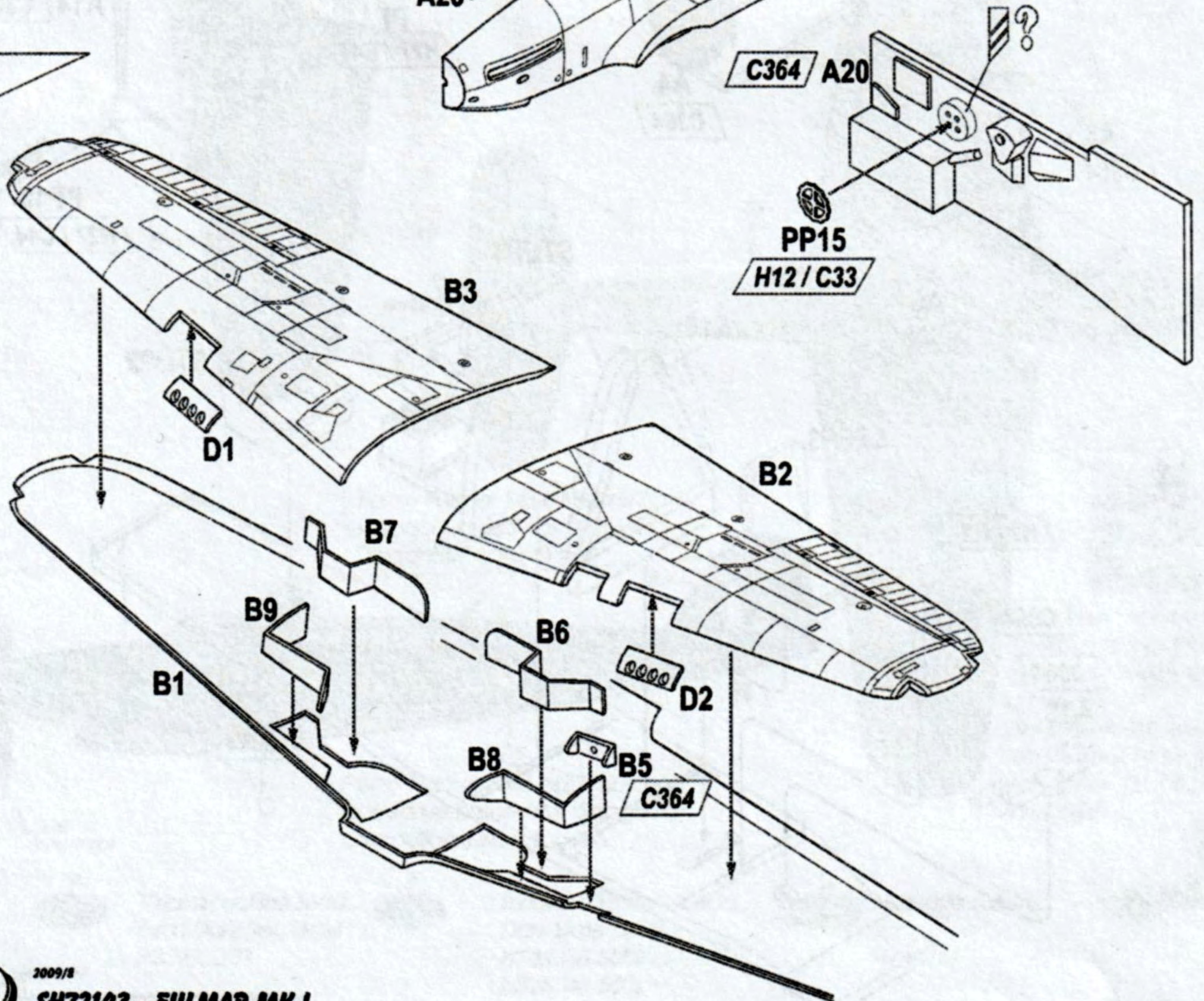

4

2009/8

SH72143 - FULMAR MK.1

7

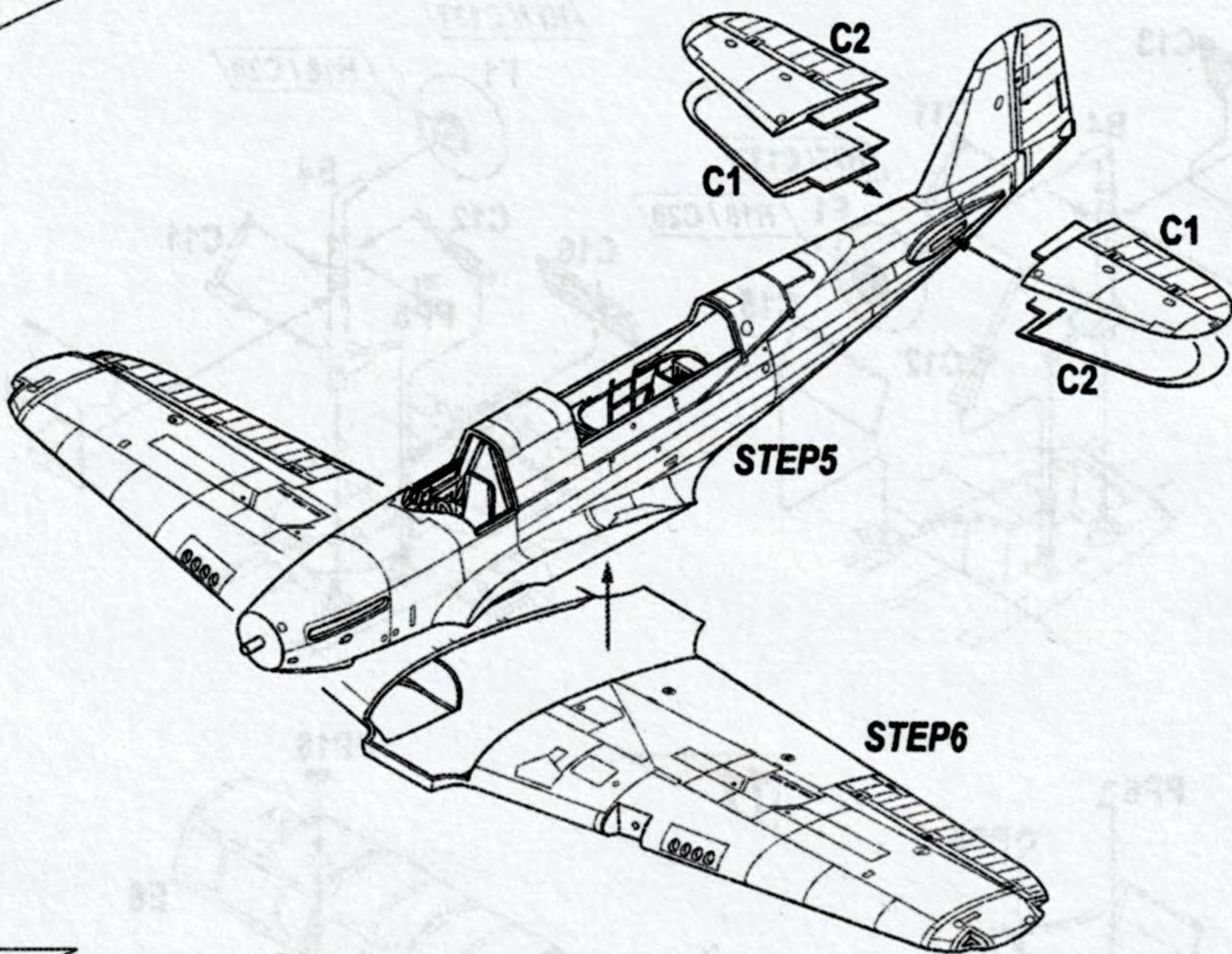

8

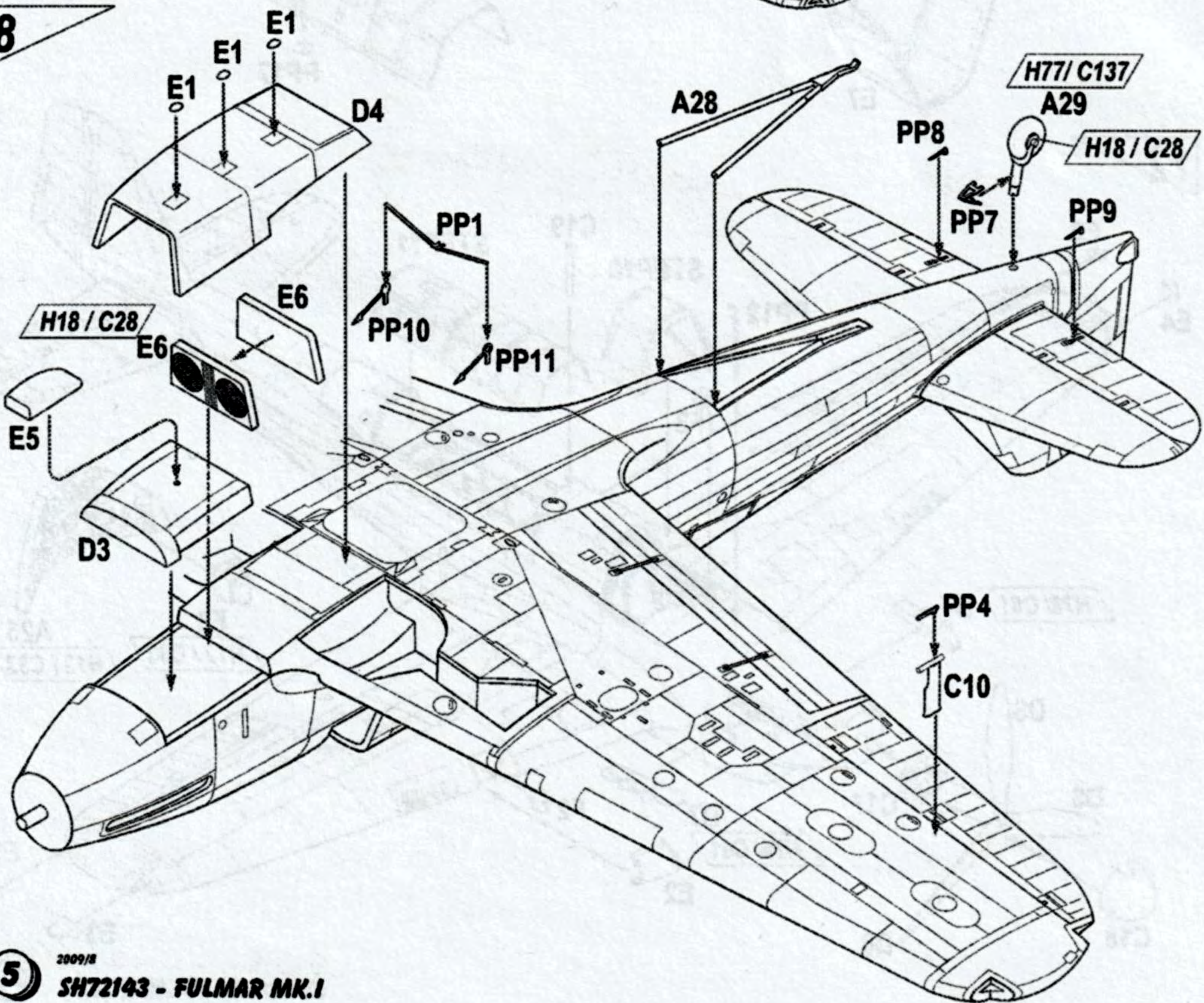

9

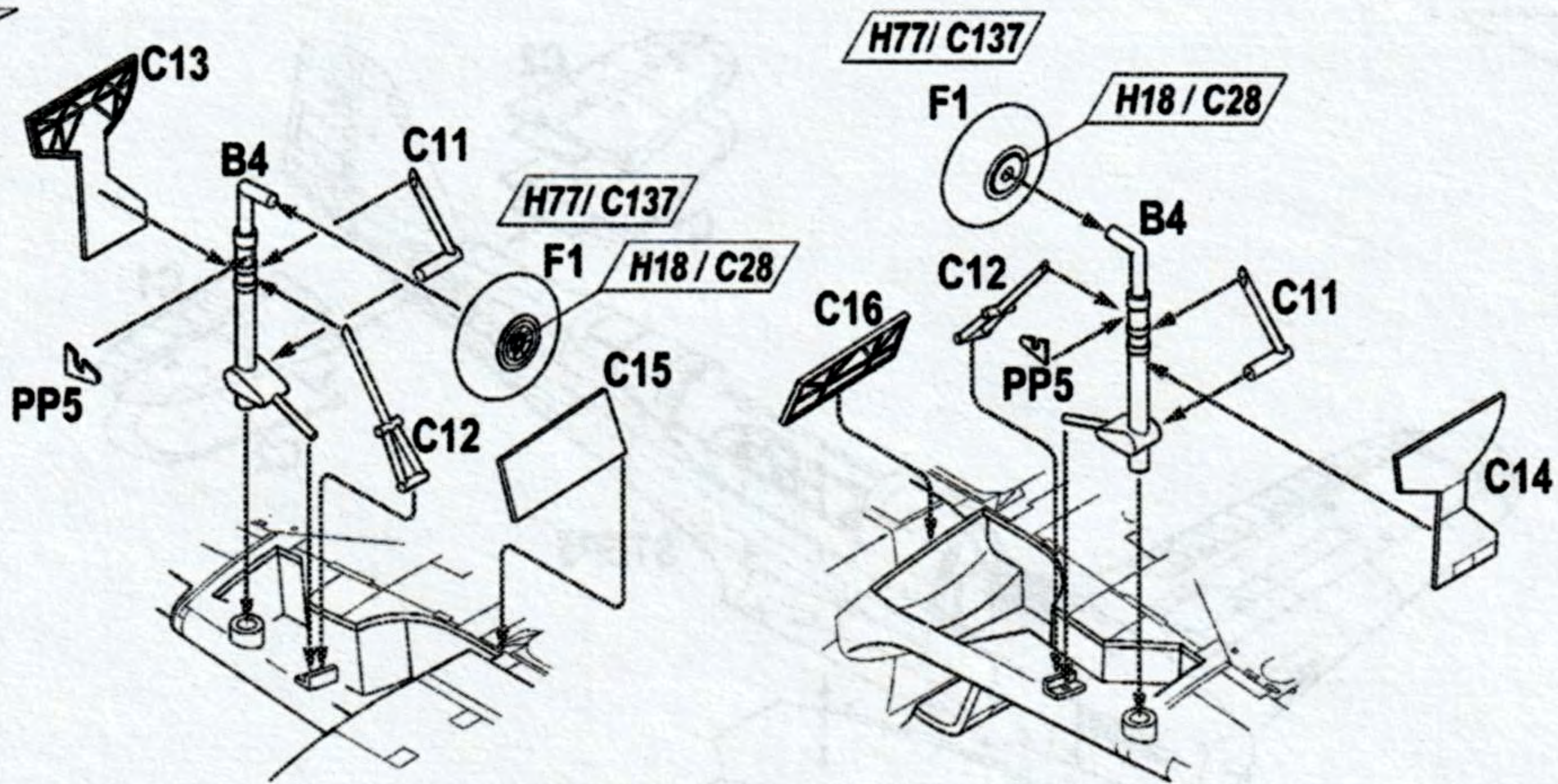

10

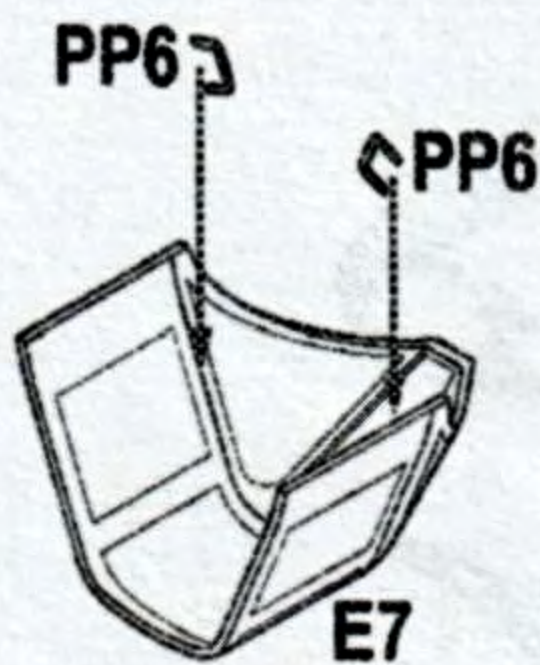

11

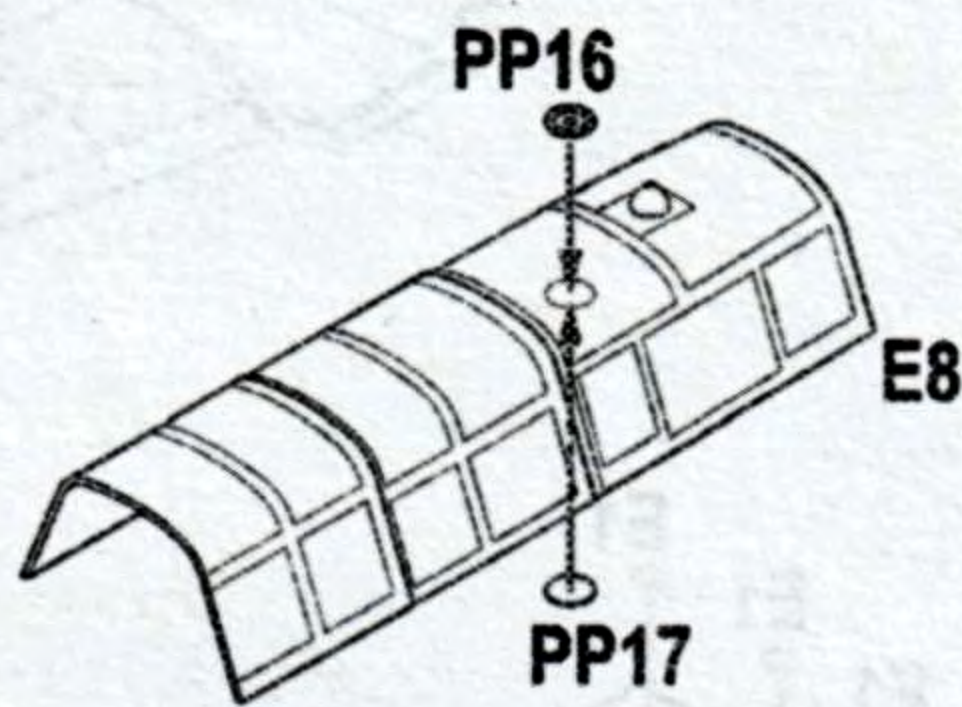

12

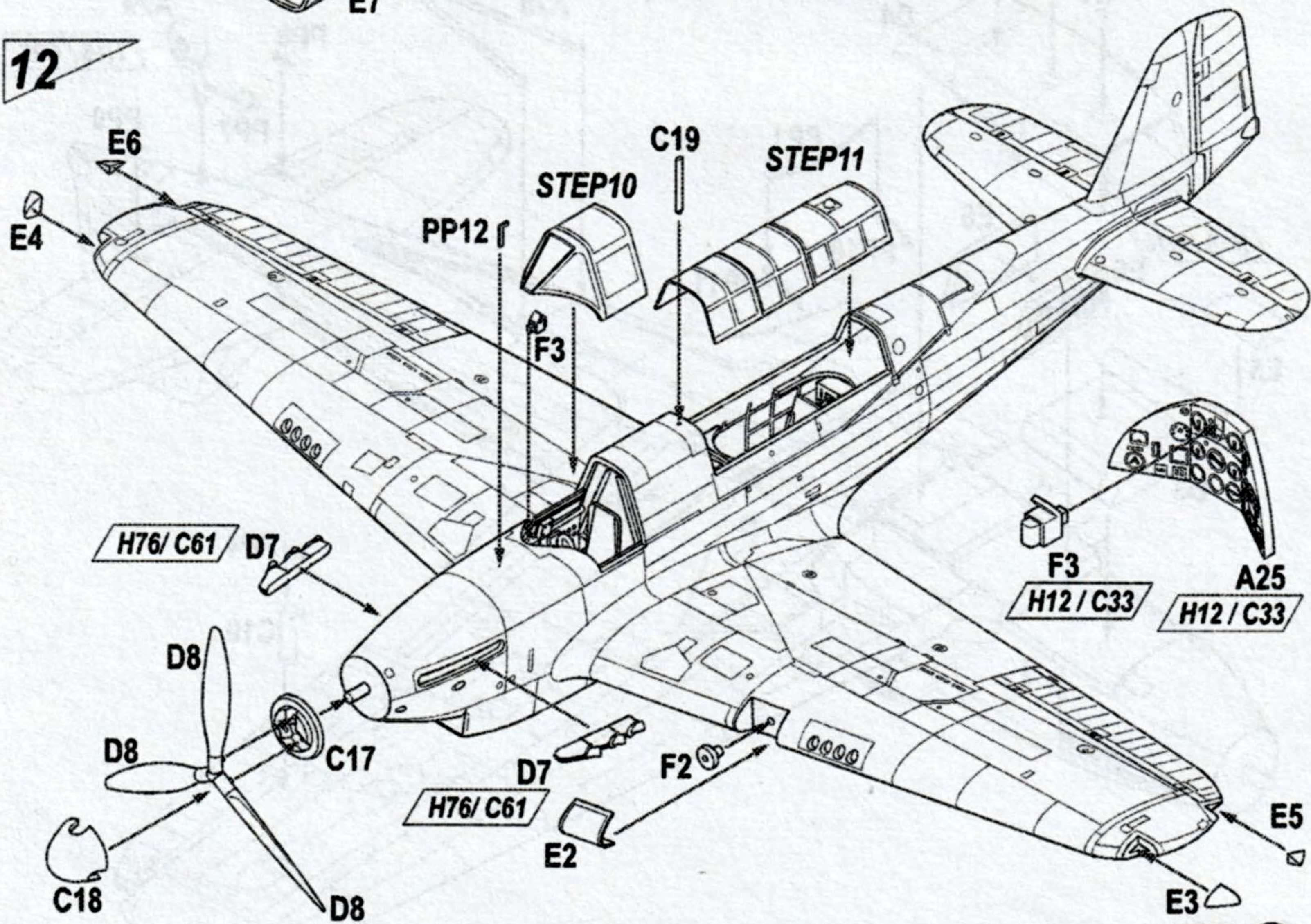

2009/2

6

Fairey Fulmar Mk.I, N1892/6K, 809.
Squadron, HMS Victorious, prosinec 1940.

Fairey Fulmar Mk.I, N1892/6K, 809th
Squadron, HMS Victorious, December 1940.

CAM. A

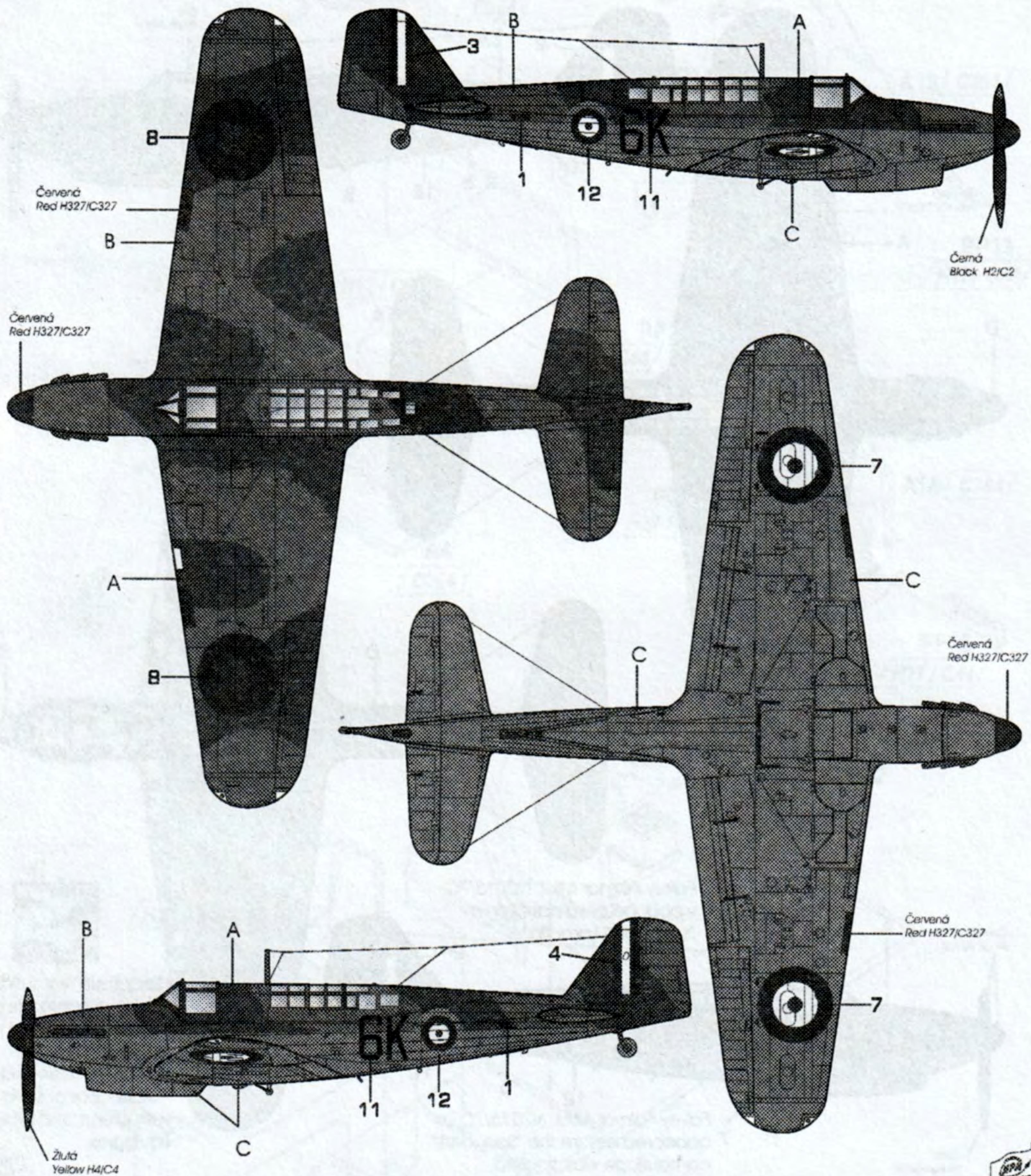

A Tmavá mořská šedá
Extra Dark Sea Grey
H333/C333

B Tmavá břidlicově šedá
Dark Slate Grey
H78/C38 50%
H32/C40 50%

C Nebeská šedá
Sky Grey
H325/C325



2009/8

SH72143 - FULMAR MK.I

7

Fairey Fulmar Mk.I, N2015/7C, 805. Squadron, HMS Eagle, únor 1941. Vrchní průhledný díl překrytu kabiny pilota byl patrně zatřen bílou barvou. Na pravé polovině křídla byly při opravě některé panely natřeny jinou barvou. Během operací ve středomoří dostal tento Fulmar na před a přední část křídla "spaghetti" kamufláž.

Fairey Fulmar Mk.I, N2015/7C, 805. Squadron, HMS Eagle, February 1941. The upper portion of the pilot's canopy was probably painted by white colour. Some of the port wing's panels were overpainted by different colour. During the operation in Mediterranean area this Fulmar received "Spaghetti" camouflage on wings' leading edges and nose lower section.

CAM. B

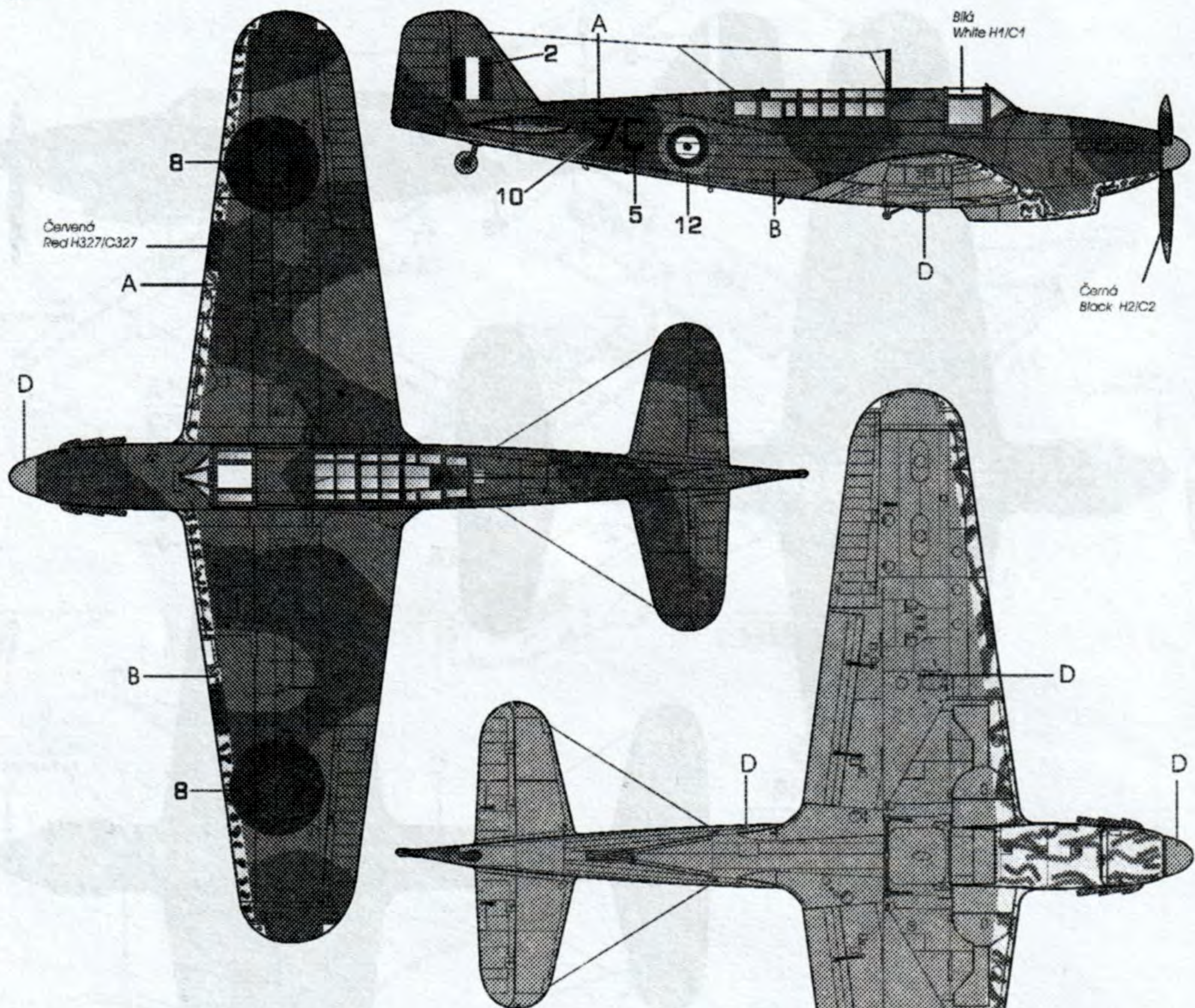

Červená
Red H327/C327

Bílá
White H1/C1

Černá
Black H2/C2

Fairey Fulmar Mk.I, N2015/7C v podobě před nastříkáním "spaghetti" kamufláže.

"Spaghetti" kamufláž - písková barva s nastříkanými skvrnami zelené a hnědé
"Spaghetti" camouflage - base coat of sand color with green and brown squiggles.

Černá
Black H2/C2

Žlutá
Yellow H4/C4

Fairey Fulmar Mk.I, N2015/7C as appeared before the "Spaghetti" camouflage was applied.

A Tmavá mořská šedá
Extra Dark Sea Grey
H333/C333

B Tmavá břidlicově šedá
Dark Slate Grey
H78/C38 50%
H32/C40 50%

D Nebeská modrá
Sky
H74/C26



Fairey Fulmar Mk.I, N4032/7R, 800.
Squadron, začátek roku 1941.

Fairey Fulmar Mk.I, N4032/7R, 800th
Squadron, beginning of 1941.

CAM. C

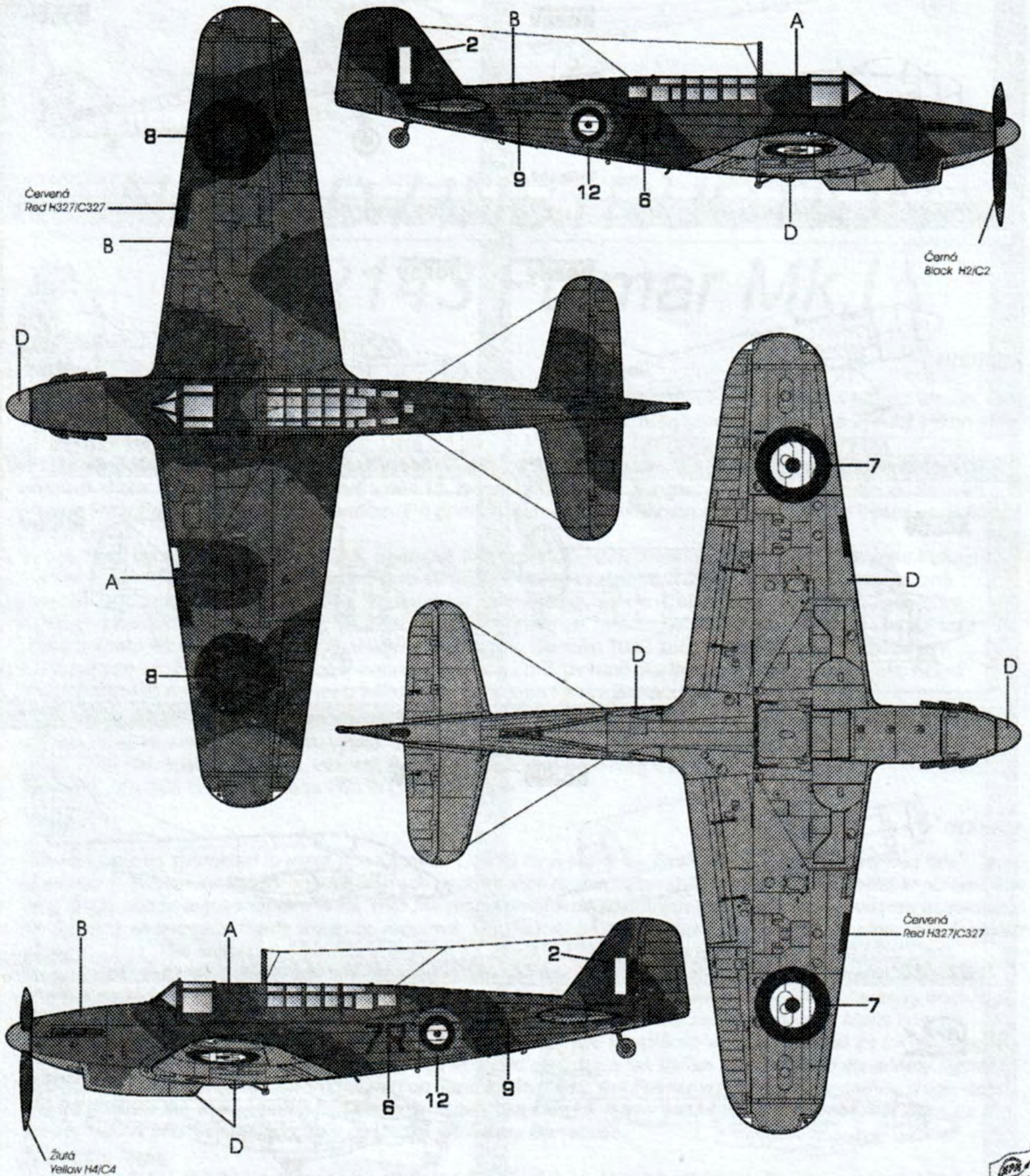

Červená
Red H327/C327

Černá
Black H2/C2

Červená
Red H327/C327

Žlutá
Yellow H4/C4



A Tmavá mořská šedá
Extra Dark Sea Grey
H333/C333



B Tmavá břidlicově šedá
Dark Slate Grey
H78/C38 50%
H32/C40 50%



D Nebeská modrá
Sky
H74/C26



2009/8

SH72143 - FULMAR MK.I

9

1/72

Other British SCALE Aircraft by Special hobby and MPM Production

special
HOBBY

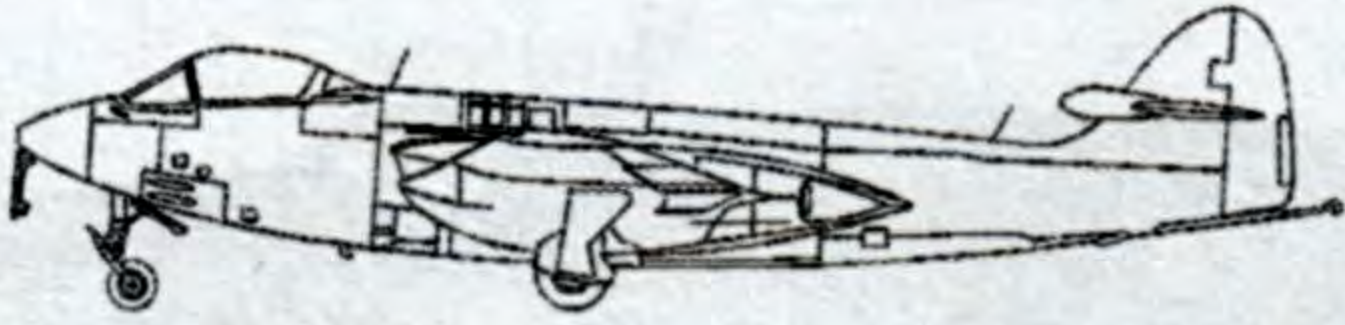

"Hi-tech"

SH72080 Hawker Sea Hawk FB Mk.3/FGA Mk.50 with AIM 9 1/72

special
HOBBY

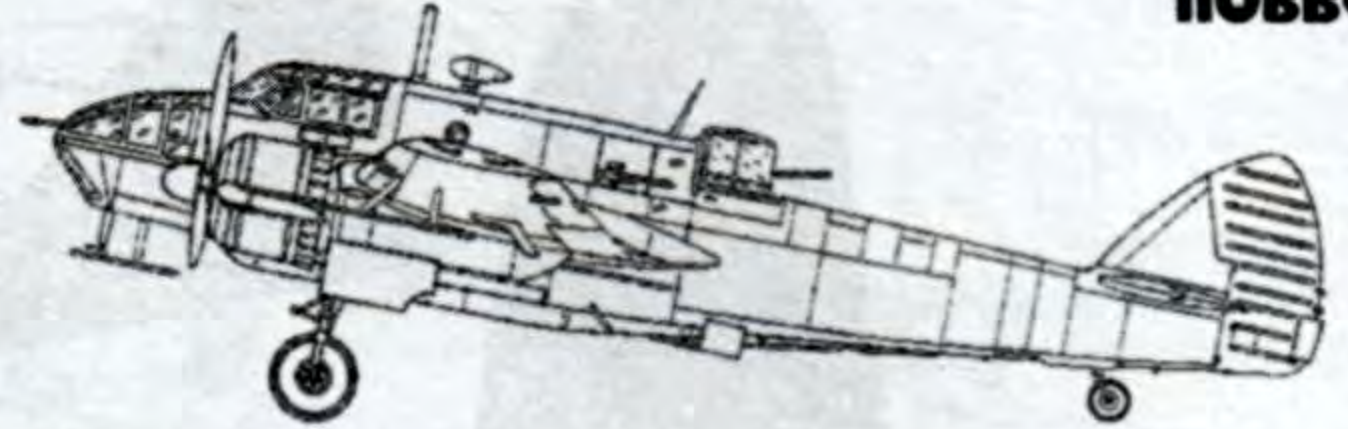

SH72083 Bristol Beaufort Mk.Ia and Mk.II 1/72

special
HOBBY

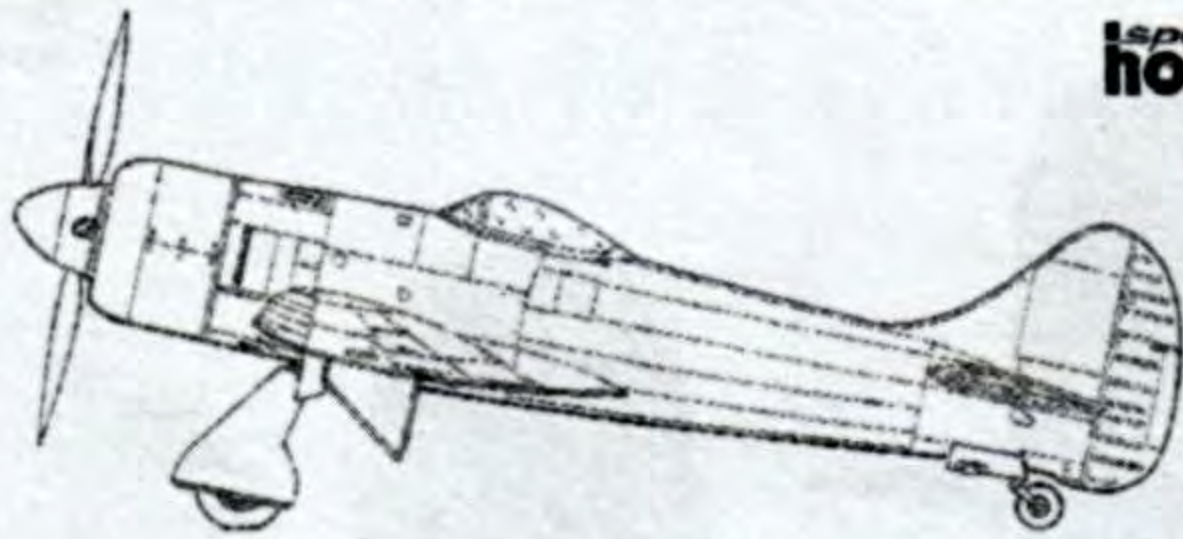

SH72103 Hawker Tempest Mk.II

1/72

special
HOBBY

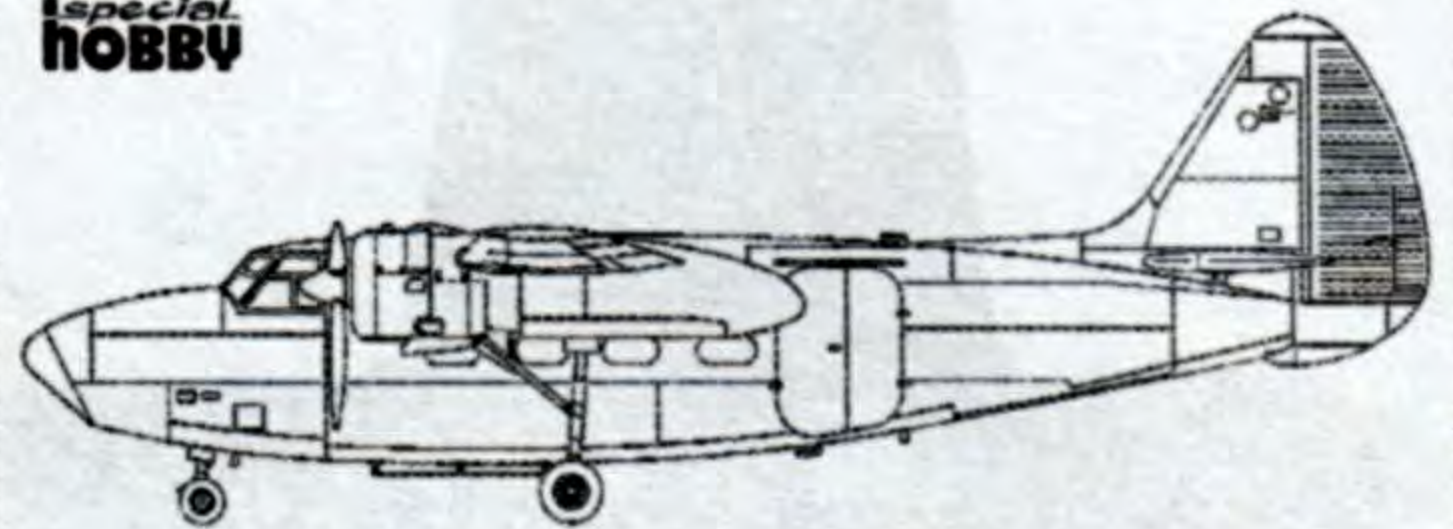

COLD WAR SPY PLANE

SH72105 HUNTING PERCIVAL PEMBROKE C Mk.1 1/72

special
HOBBY

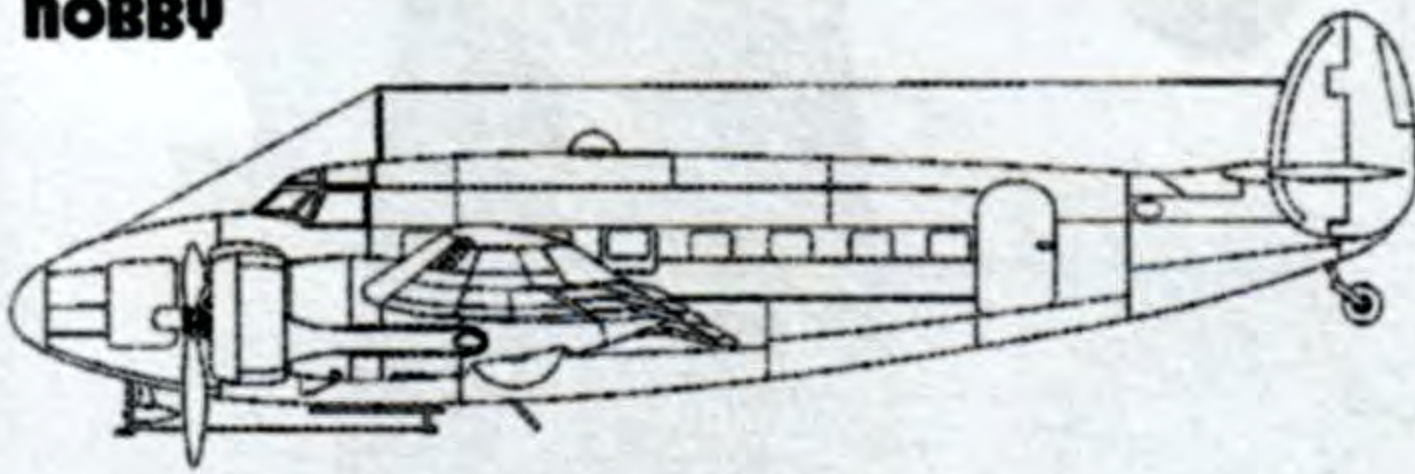

SH72112 C-60 Lodestar 'A'

1/72

special
HOBBY

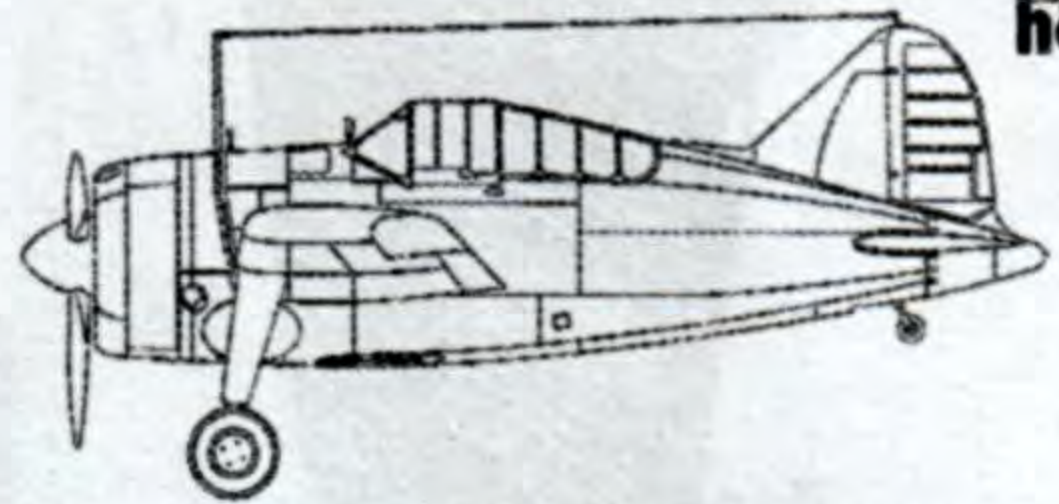

SH72131 Brewster model 339E Buffalo Mk.1

1/72

special
HOBBY

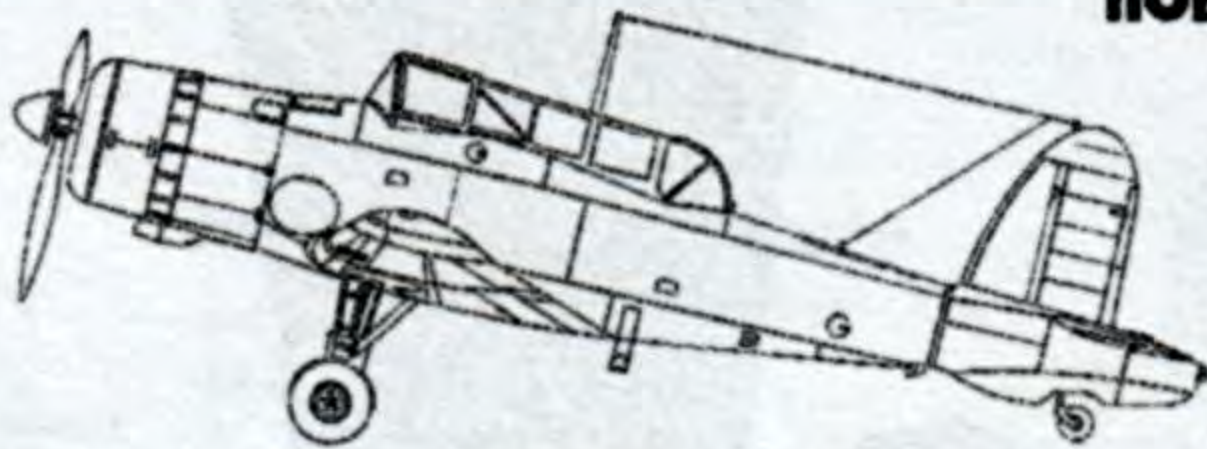

SH72140 Blackburn Skua Mk. II

1/72

special
HOBBY

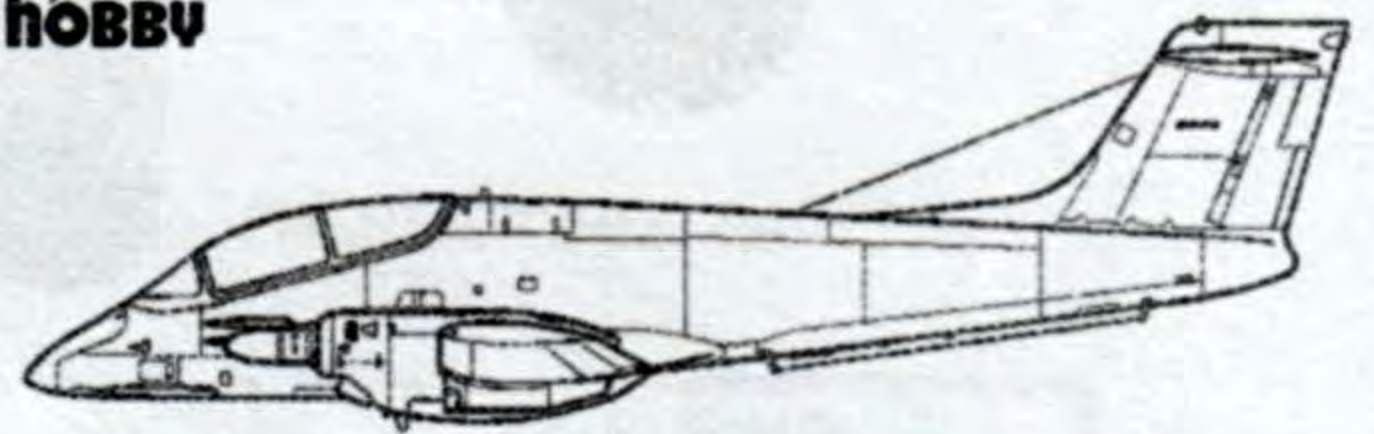

SH72177 FMA IA.58A Pucará 'In Foreign Service'

1/72

MPM
Production

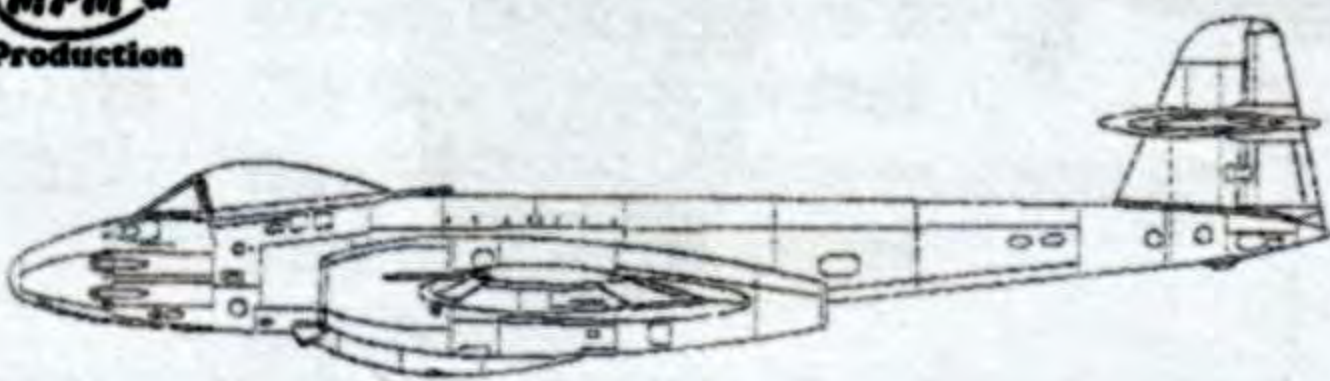

72531 Gloster Meteor F Mk.8

1/72

MPM
Production

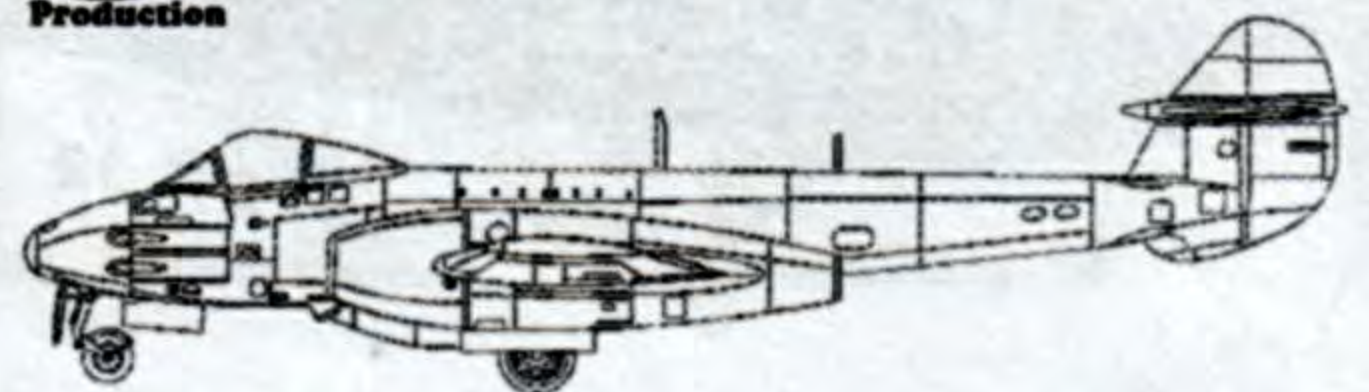

72558 Gloster Meteor Mk. IV

1/72



Bližší informace na internetových stránkách www.cmkkits.com

Further information at internet pages www.cmkkits.com

CAM. A



Fairey Fulmar Mk.I, N1892/6K, 809. Squadron, HMS Victorious, prosinec 1940.

Fairey Fulmar Mk.I, N1892/6K, 809th Squadron, HMS Victorious, December 1940.

CAM. B

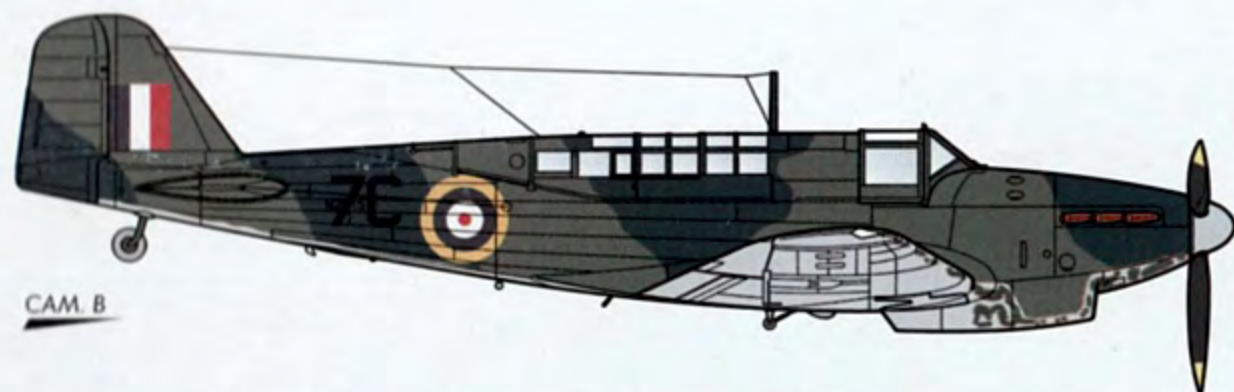

Fairey Fulmar Mk.I, N2015/7C, 805. Squadron, HMS Eagle, únor 1941. Vrchní průhledný díl překrytu kabiny pilota byl patrně zatřen bílou barvou. Na pravé polovině křídla byly při opravě některé panely natřeny jinou barvou. Během operací ve středomoří dostal tento Fulmar na přední a přední část křídla "spaghetti" kamufláž.

Fairey Fulmar Mk.I, N2015/7C, 805. Squadron, HMS Eagle, February 1941. The upper portion of the pilot's canopy was probably painted by white colour. Some of the port wing's panels were overpainted by different colour. During the operation in Mediterranean area this Fulmar received "Spaghetti" camouflage on wings' leading edges and nose lower section.

CAM. C



Fairey Fulmar Mk.I, N4032/7R, 800. Squadron, začátek roku 1941.

Fairey Fulmar Mk.I, N4032/7R, 800th Squadron, beginning of 1941.

