

## HISTORY

In the early 1960's, the need for a light multipurpose aircraft became apparent. A design competition was held and in August of 1964 the North American Bronco was chosen from the many entries.

The airplane went on to serve the U.S. Air Force, the Marines, and the Navy. Additional planes were built for West Germany, Thailand, and Venezuela.

The powerful twin turbo-prop engines are ideal for low altitude missions such as light armed reconnaissance, helicopter escort, air drops, and forward air control.

With a wingspan of 40 ft. and a total length of 41 ft. 7 in., the OV-10A Bronco can takeoff and land on an airstrip only 740 ft. in length! The plane's rugged landing gear even permits the use of unprepared fields.

## SPECIFICATIONS

Engines	2	Garret-AiResearch turboprops, T76-G, of 715 shaft horsepower each
Max. Speed		244 Knots
Range		1200 miles
Weight Empty		7,190 lbs.
Weight Loaded		14,444 lbs.
Armament	4	7.62mm M60C machineguns plus a variety of underslung ordnance.

## BEFORE STARTING

1. Study the illustrations and sequence of assembly before beginning.
2. Decide how much detail you wish to add to your model and whether or not you intend to modify or "convert" the basic model in any way. Study carefully all available reference material before beginning to ensure an authentic model.
3. Due to the amount of parts in this kit, do not detach the parts from the runner of the parts tree until you need them. This helps avoid confusion and lost parts.
4. When cementing the parts together, check the way one part fits together with another. This assures a neat job with no surprises.
5. Always remember when working with plastic model cement and paint to keep your work area well ventilated. The fumes from plastic modeling products can be harmful if inhaled.

## PREPARATION OF PARTS

1. Never tear parts off the runner (parts tree). Use a Testor Hobby Knife, fingernail clippers, or a small wire cutters to remove the parts from the tree.
2. It is possible some parts may require a little attention with a file or sandpaper to ensure a proper fit and neat appearance. Hobby files and Testor Hobby Sandpaper appropriate for model building are available in most good hobby shops.
3. If you desire you may fill any seams (where parts go together) or imperfections with Testor Contour Putty for Plastic Models which is also available at good hobby shops.

## PAINTING

You can obtain an excellent finish on your model using Testor finish preparation products and paints. Detailed descriptions of paint types and color are included on the pages that follow.

Good brushes are essential for proper detailing. Testor *Model Master* brushes are recommended and available at good hobby stores. Be sure you have the entire selection for all your modeling needs. Always clean them in Testor thinner, wash in soap and water, and store with bristles upward when not in use.

Wash plastic parts before detaching them from the parts tree. Warm water and liquid dishwashing detergent will remove the oils left from the manufacturing process. Let the parts dry and avoid excessive handling. Immediately before painting, wipe the parts with a "tac rag" (available at auto parts stores) to remove dust and lint.

Most small parts are best painted while still attached to the parts tree. You can also detach them and hold with tweezers or "magic" tape while painting. Paint in one direction only. If your paint is the correct thickness brush strokes will disappear as the color dries. If the paint seems too thick, thin with Testor Paint Thinner. Wheels may be detached from the parts tree and fit onto toothpicks or matchsticks for painting. Just hold the paintbrush against the edge of the wheel and rotate the stick and wheel to obtain a neat finish.

Let the paint dry completely before handling. When the parts are dry, assemble the model, following the directions closely. Remember cement will not hold strongly to painted surfaces. Use your Testor Hobby Knife to carefully remove paint from all surfaces to be cemented. After you have assembled the model you can touchup areas where cement might have marred the finish.

The Testor **Model Master** paint system is specially designed to be used on military models. The **Preliminary Painting** instructions on this sheet indicate which **Model Master** colors to use as indicated by name and Federal Standard (FS) number. These colors are called out by **bold italic type**. Wherever **Model Master** colors are not applicable the required Testor color will be called out by number and name in **regular bold type**.

## 1 NOSEGEAR / COCKPIT FLOOR

### Preliminary Painting

1, 2 interior surfaces (shaded area):

**No. 1740 Dark Gull Gray FS 36231**

12 nose gear, hub:

**No. 1768 Flat White FS 37875**

26 both sides:

**No. 1740 Dark Gull Gray**

12 tire only:

**No. 1749 Flat Black FS 37038**

**NOTE:** See **WEATHERING HINTS** on page 10.

### Assembly

1. Cement nose gear 12 to right fuselage half 2.
2. Refer to Fig. A which show the proper location of cockpit floor in the fuselage.
3. Cement cockpit floor 26 to right fuselage half 2. Add nose weight - see NOTE below.
4. Cement fuselage halves 1 and 2 together, *carefully* guiding landing gear and cockpit floor into left fuselage half 1.
5. Apply instrument panel decal 1 as indicated in Fig. A. See **APPLYING DECALS** on pages 6 or 8.

### Nosegear / Cockpit Floor

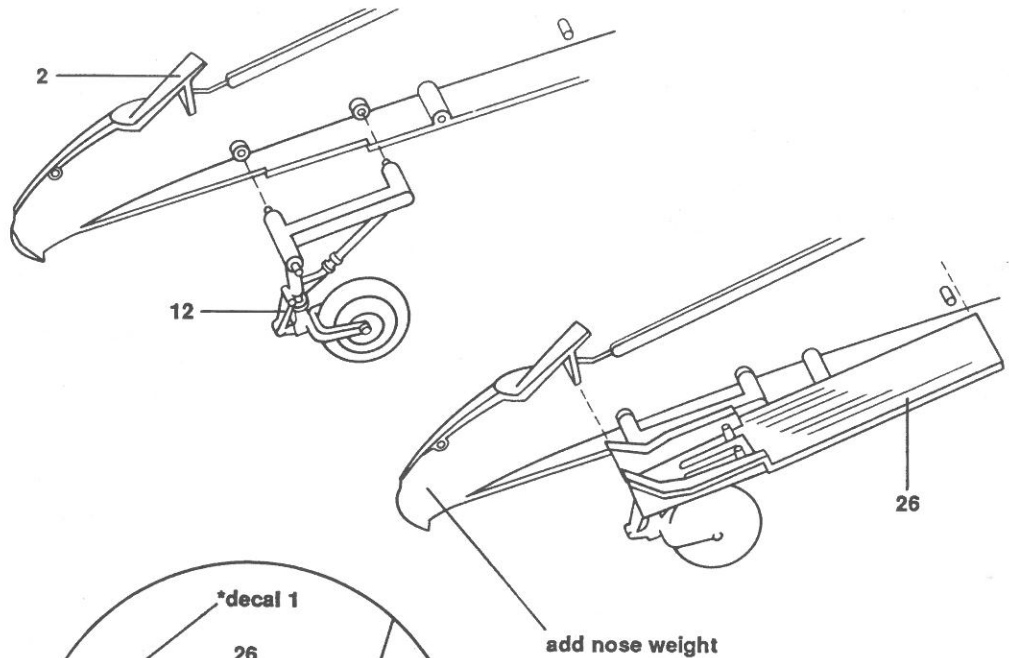

Fig. A

\*see **APPLYING DECALS** on pages 6 or 8.

**Note:** In order for this model to rest properly on its tricycle landing gear, weight must be added inside the nose before assembling the fuselage halves. Lead split shot as used in fishing is recommended. Lead weights should be held in place with modeling clay or epoxy...do not use plastic cement!!

## 2 SEAT

### Preliminary Painting

25 seat headrest (shaded area):

**No. 1705 Insignia Red FS 31136**

25 seat:

**No. 1740 Dark Gull Gray FS 36231**

27 seatback:

**No. 1749 Flat Black FS 37038**

### Assembly

1. Cement seatback 27 to seat 25 as shown.
2. Cement seat unit to cockpit floor.

### Seat Assembly

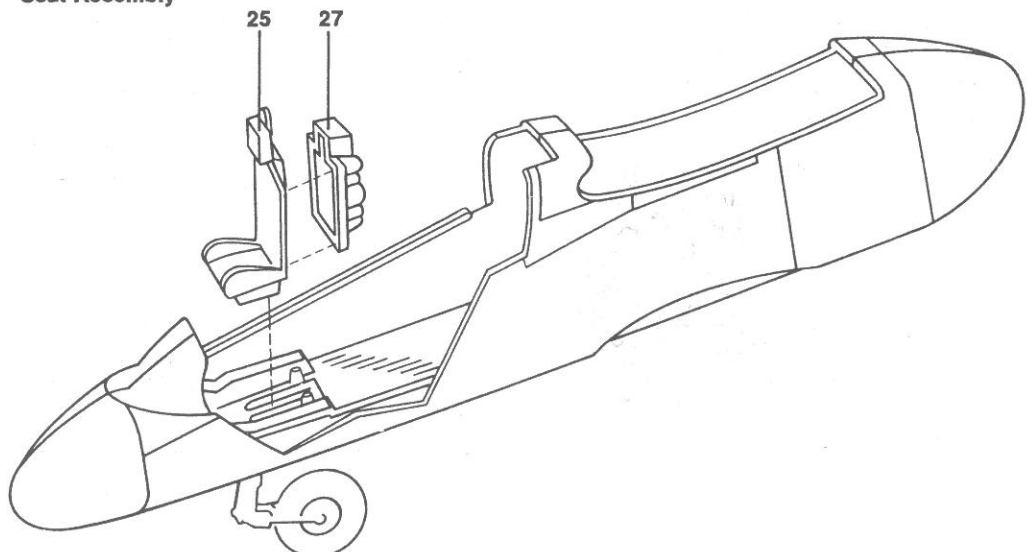

### 3 SPONSONS

#### Preliminary Painting

34 machinegun barrels:  
No. 1795 Gunmetal

#### Assembly

1. Cement sponson halves 9A to 9B and 8A to 8B as shown.
2. Cement sponsons to fuselage.
3. Cement machinegun barrels 34 to sponsons as shown.

Sponsons

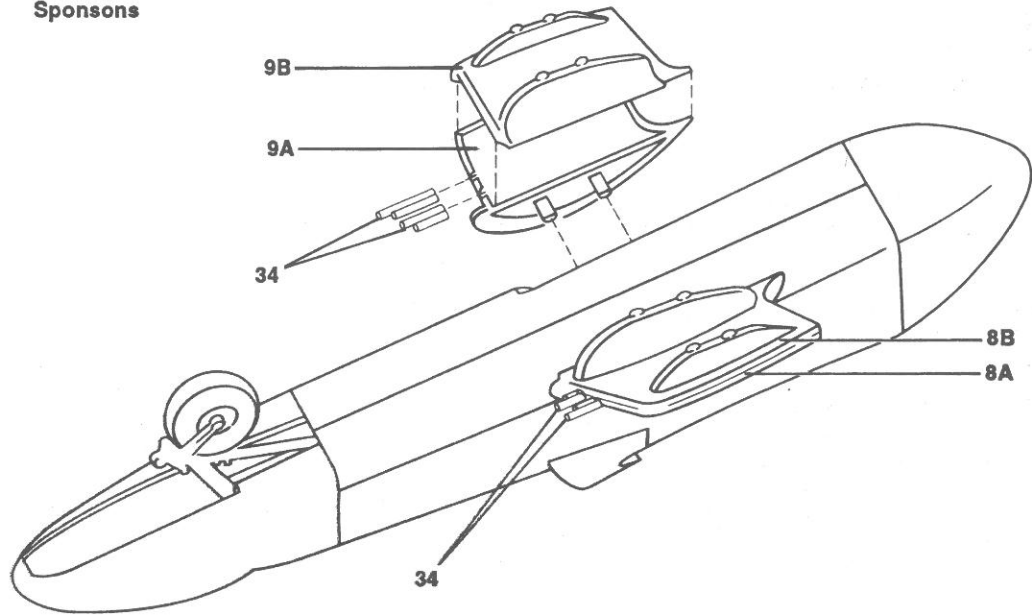

### 4 PROPELLER UNITS

#### Preliminary Painting

17, 18 spinner parts - Marine Version:  
No. 1749 Flat Black FS 37038

17, 18 spinner parts - Air Force Version:  
Camouflage scheme per drawings  
on pages 8 and 9.

22, 23 propeller blades - Marine Version:  
No. 1749 Flat Black

22, 23 propeller blades - Air Force Version:  
No. 1781 Aluminum

22, 23 propeller tip stripes - Marine Version:  
No. 1705 Insignia Red FS 31136 and  
No. 1768 Flat White FS 37875

22, 23 propeller tip stripes - Air Force  
Version:  
No. 1708 Insignia Yellow  
No. 1749 Flat Black  
No. 1768 Flat White

See Fig. B for propeller tip stripes painting.

#### Assembly

1. Cement spinner parts 17 and 18 together. Make 2 spinners.
2. Assemble the right side propeller unit, using three blades 22. Note the blade angle - see arrow.
3. Cement three blades 23 to the remaining spinner, for the left side propeller unit. Note the blade angle - see arrow.
4. Slip (do not cement) the propeller units through the intake scoops 13 and cement the retainers 38 to the prop shafts. Do not allow cement to touch intake scoops or props will not spin.

Right Propeller

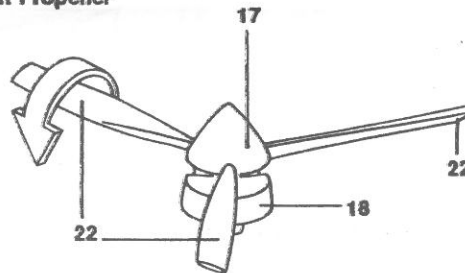

Left Propeller

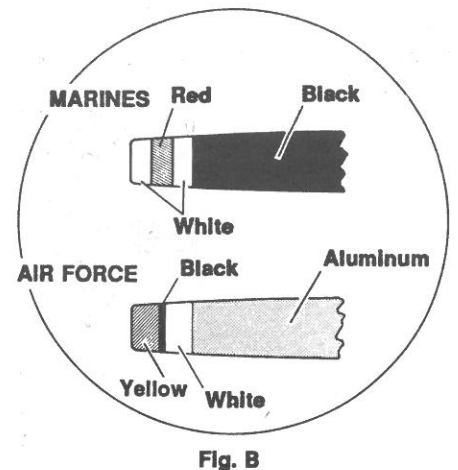
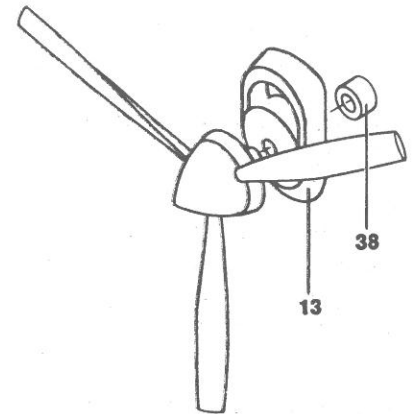
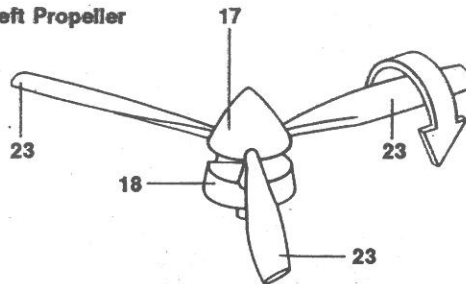

## 5 BOOMS

### Preliminary Painting

19 tires:

*No. 1749 Flat Black FS 37038*

19 hubs; 10, 11 landing gear:

*No. 1768 Flat White FS 37875*

4A, 4B, 3A, 3B boom halves - shade areas inside:

*No. 1768 Flat White*

Exhaust stacks:

*No. 1796 Jet Exhaust*

### Assembly

- Left Boom:** Cement one wheel 19 to left landing gear 10. Cement landing gear 10 into boom half 4B. Cement boom half 4A to 4B. Cement one exhaust stack to boom as shown.
- Right Boom:** Cement remaining wheel 19 to right landing gear 11. Cement landing gear 11 into boom half 3A. Cement boom half 3B to 3A. Cement remaining exhaust stack to boom as shown.

Booms  
Left Shown  
Right - Opposite

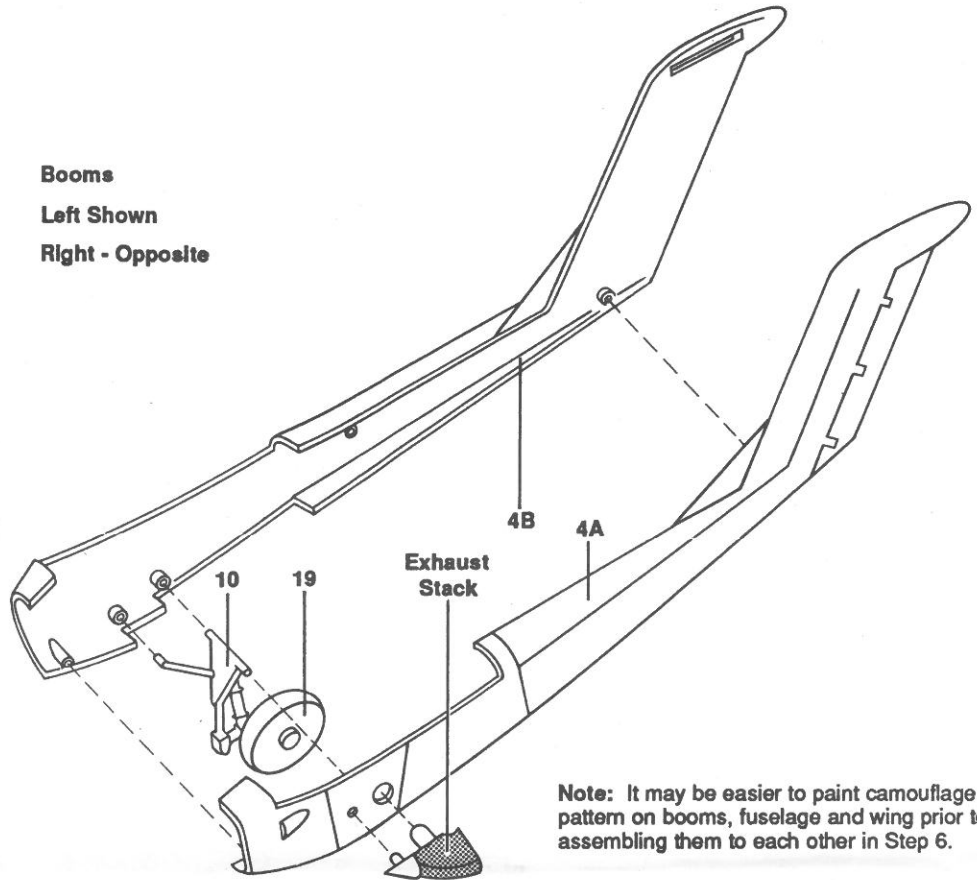

**Note:** It may be easier to paint camouflage pattern on booms, fuselage and wing prior to assembling them to each other in Step 6.

## 6 FUSELAGE / BOOMS / WING

### Preliminary Painting

37 anti-collision beacon:

*No. 1705 Insignia Red FS 31136*

Wingtip Light - right:

*No. 1124 Green*

Wingtip Light - left:

*No. 1705 Insignia Red*

### Assembly

- Cement wing halves 5 and 6 together.
- Cement wing to fuselage.
- Cement left and right booms to bottom of wing.
- Cement stabilizer 7 between booms - flat side up.
- Cement propeller units to booms - note correct placement/blade angles.
- Cement anti-collision beacon 37, and elevator counter-balance 35 in place as shown.

Fuselage / Booms / Wing

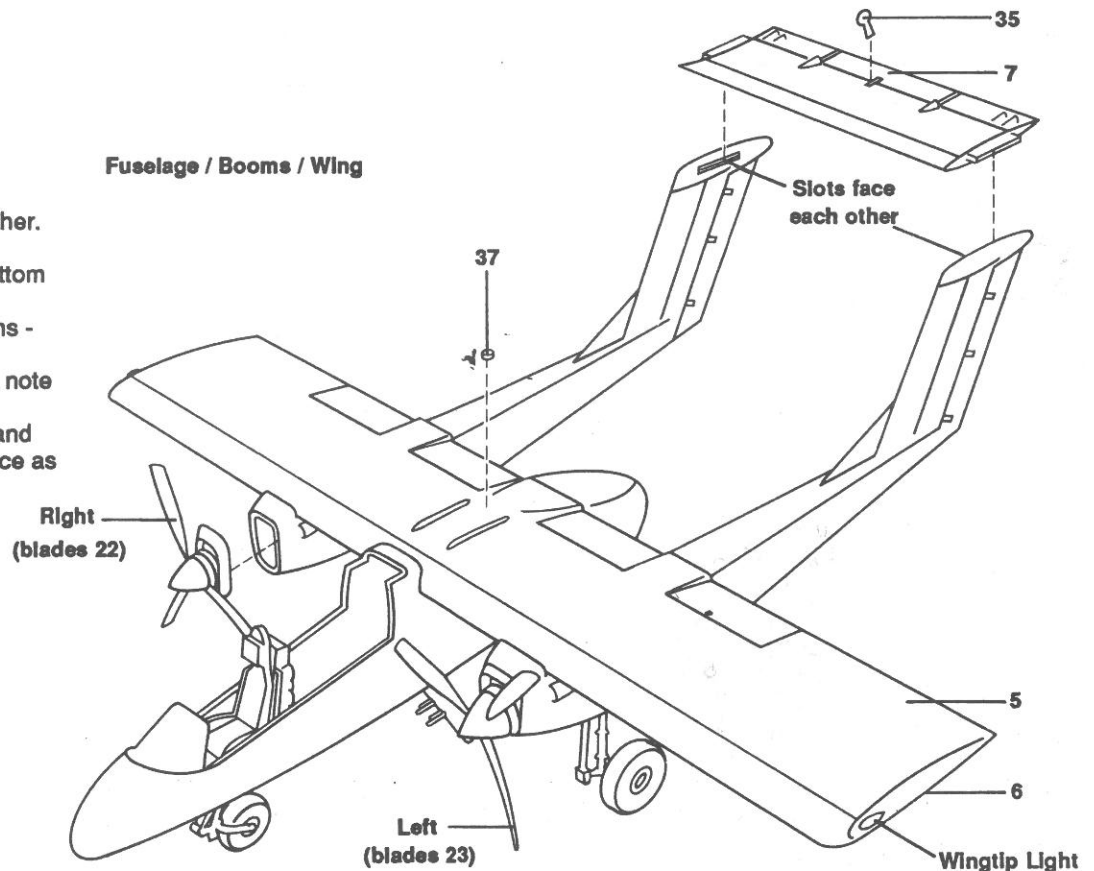

# 7 FINAL ASSEMBLY

## Preliminary Painting

15, 16, 32 bombs:

*No. 1711 Olive Drab FS 34087*

28A, 28B, 29, 30, 31A, 31B landing gear doors - interior only:

*No. 1768 Flat White FS 37875*

37 anti-collision beacon:

*No. 1705 Insignia Red FS 31136*

Canopy frames:

camouflage per drawings on pages 6 through 9.

Pilot:

Suit - *No. 1711 Olive Drab*

Helmet - *No. 1768 Flat White* or it may be painted any color you choose since the helmet is considered personal gear and could be a variety of colors.

Shoes, gloves, oxygen mask - *No. 1749 Flat Black*

36 pitot tube-tip:

*No. 1781 Aluminum*

## Assembly

1. Cement bomb halves 15, 16 and two fins 32 together as shown. Make 4 bombs. Cement bombs in place as shown.
2. Cement main gear doors 30, 31A and 31B to both booms as shown.
3. Cement nosegear doors 28A, 28B and 29 in place.
4. Cement anti-collision light 37 to fuselage as shown.
5. Paint pilot and cement to seat.

6. *Carefully* glue Windshield in place, then Upper Canopy, then Canopy Side pieces.
7. Cement pitot tube 36 to nose as shown.

**Note:** It may be easier to paint and decal your model if underwing stores and/or armament are left off until model is completely finished.

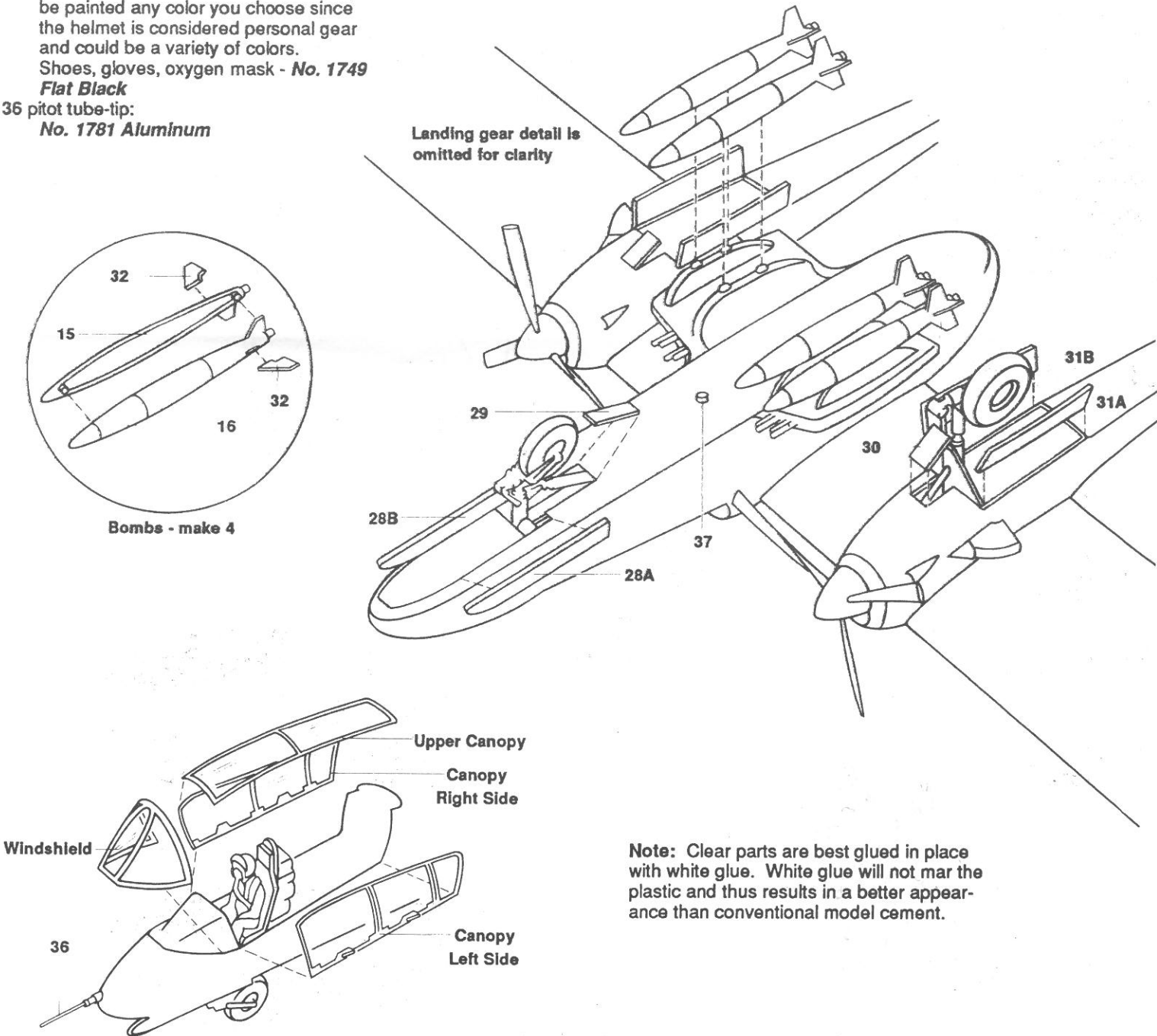

**APPLYING DECALS**

1. After carefully masking clear areas, spray entire model with Testor Glosscote #1261. Decals adhere best to a smooth surface and the shinier the finish the smoother it is. Allow the Glosscote to dry before going further.
2. Select the decals you plan to use and cut them from the decal sheet with scissors or a Testor Hobby Knife.
3. Working with only one decal at a time, dip the decal in clear water for no more than five seconds. Remove it from the water and place on a dry paper towel for about one minute.
4. When the decal slides easily on the backing paper, slide it to the edge of, and onto the surface of the model with a soft Testor *Model Master* paint brush or tweezers. Remember the decals are very thin and can be easily ripped. Work slowly and carefully.
5. Once the decal is in the desired position apply a small amount of Testor Decal Set #8804. This will help the decal conform to any irregularities in the surface of the model. Allow the decal to dry undisturbed. Should you desire to purposely move it before it has dried, apply a little Decal Set to a soft brush and push the decal slowly into the desired position.
6. When the decals are completely dry (usually overnight), apply a coat of Testor Dullcote, #1260, to the entire model. This will give it an authentic, dull finish and protect the surface of the model. Now you can carefully remove the masking from the clear parts.

**NOTE:** Only two of the ejection seat warning triangles, decal 2, are required on this version of the OV-10A.

**OV-10A  
U.S. MARINE CORPS**

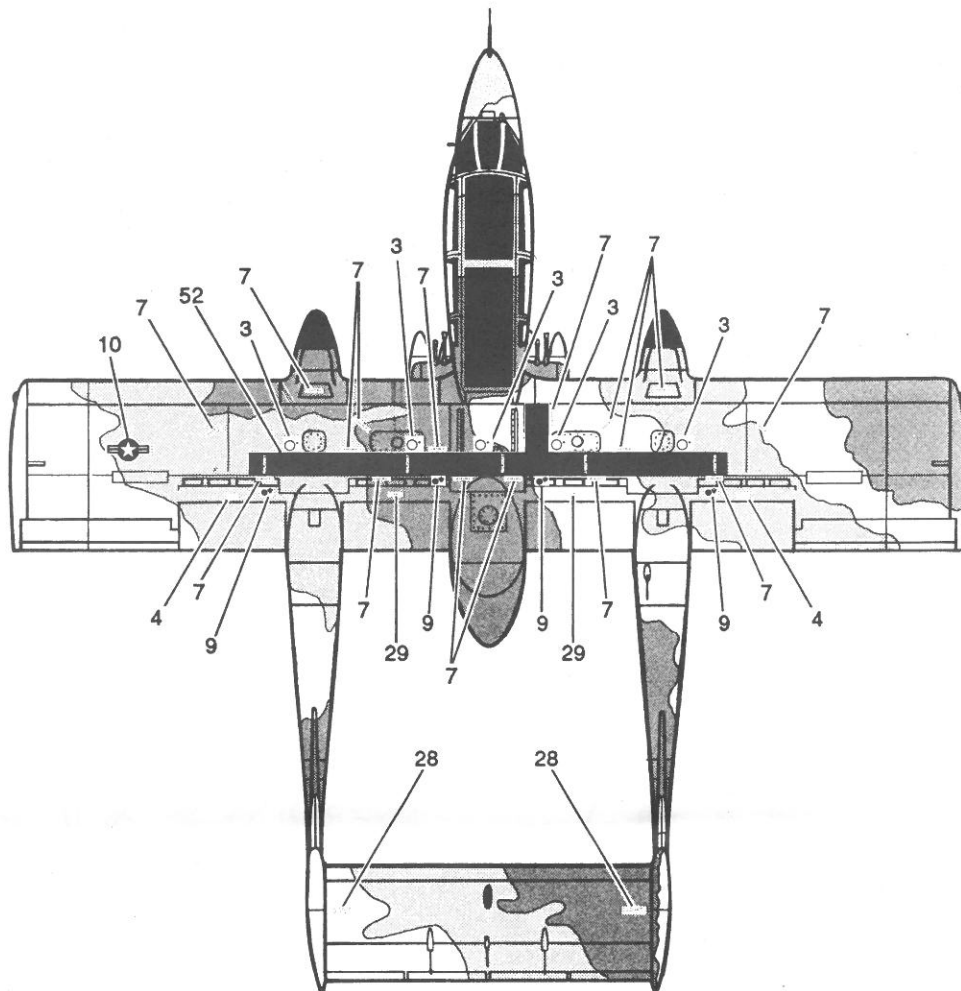

**PAINTING**

-  **No. 1732**  
Light Gray  
FS 36495
-  **No. 1714**  
Forest Green  
FS 34127
-  **No. 1749**  
Flat Black  
FS 37038

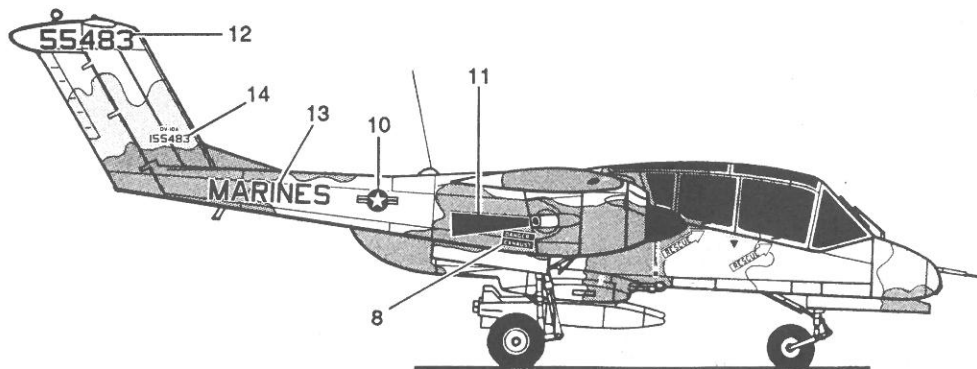

**HISTORICAL NOTE:**

The paint scheme shown on the Marine OV-10A is an experimental scheme used on only a few OV-10D aircraft. The scheme, as far as we know, might have been tested on the OV-10A but we are not certain of that. We elected to show it on the model because it is one of the nicest looking paint schemes to be flown on the *Bronco*.

The scheme shown for the U.S. Air Force OV-10A version is absolutely authentic.

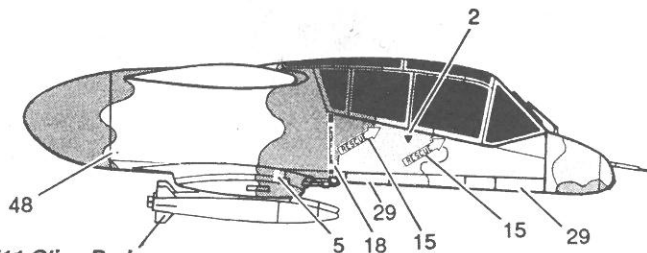

**Bombs - No. 1711 Olive Drab**

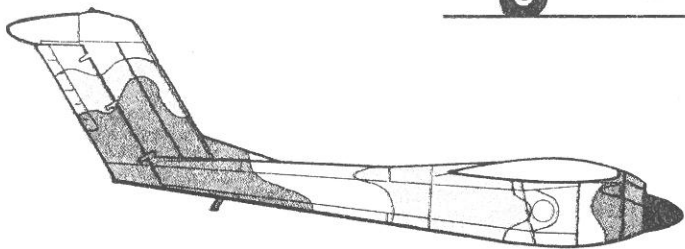
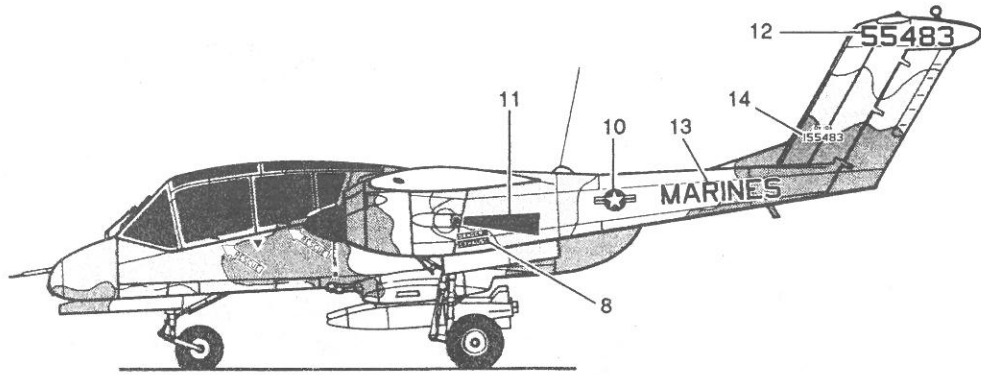
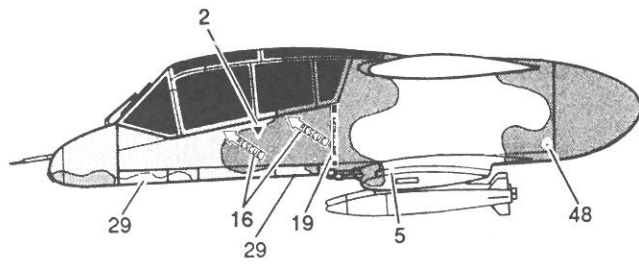

INBOARD LEFT BOOM

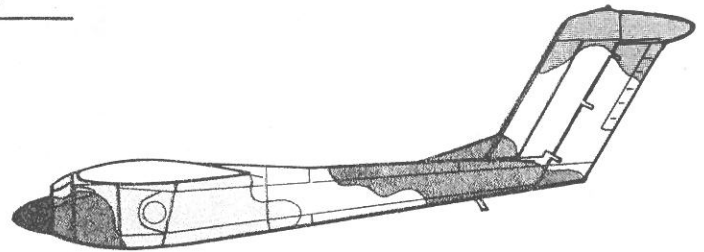

INBOARD RIGHT BOOM

The numbers indicate decals.

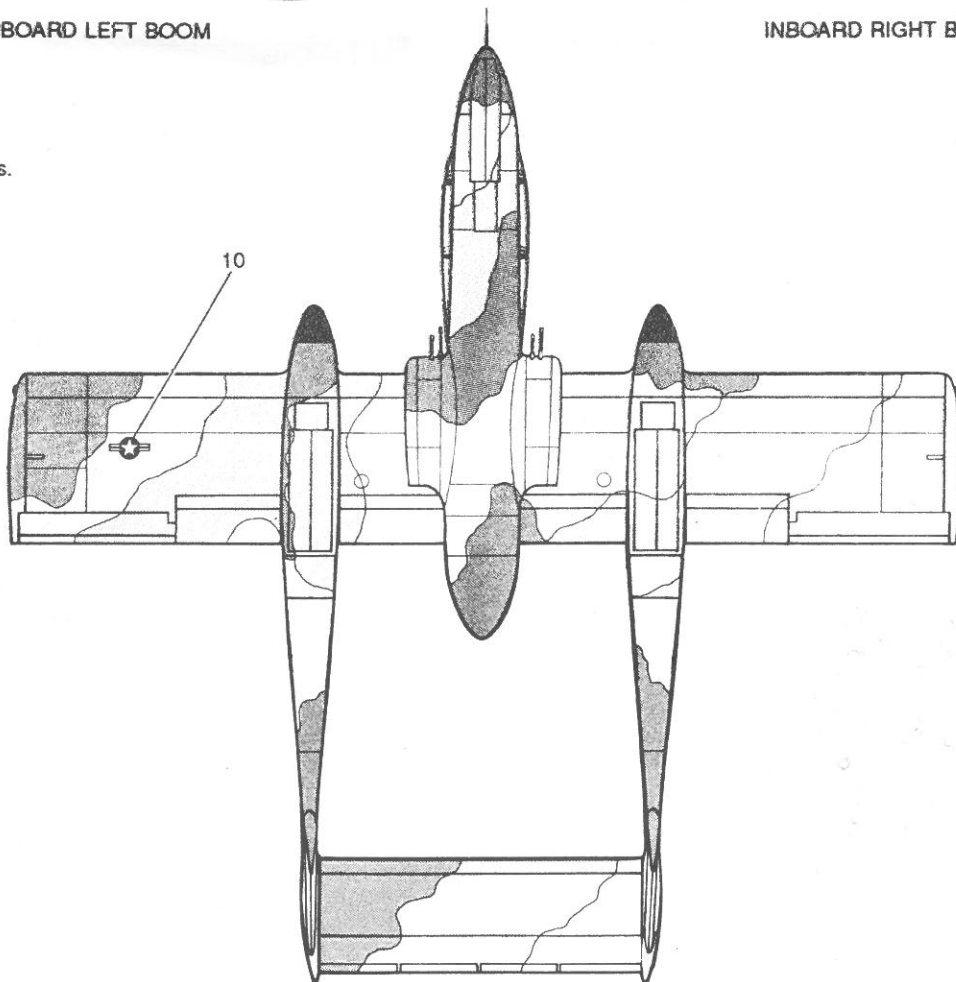



**OV-10A**

U.S. AIR FORCE  
 27th Tactical Air Support Squadron (TASS)  
 George AFB, California  
 Flown by its Commanding Officer,  
 Col. Bob Johnston

**NOTE:** Alternate "Low Visibility" markings are also provided for a second OV-10A assigned to the 27th TASS. Camouflage painting is identical as are all markings and insignia except where indicated.

**PAINTING**

-  **No. 1713**  
 Medium Green  
 FS 34102
-  **No. 1764**  
 Euro I Dk. Green  
 FS 34092
-  **No. 1723**  
 Gunship Gray  
 FS 36118

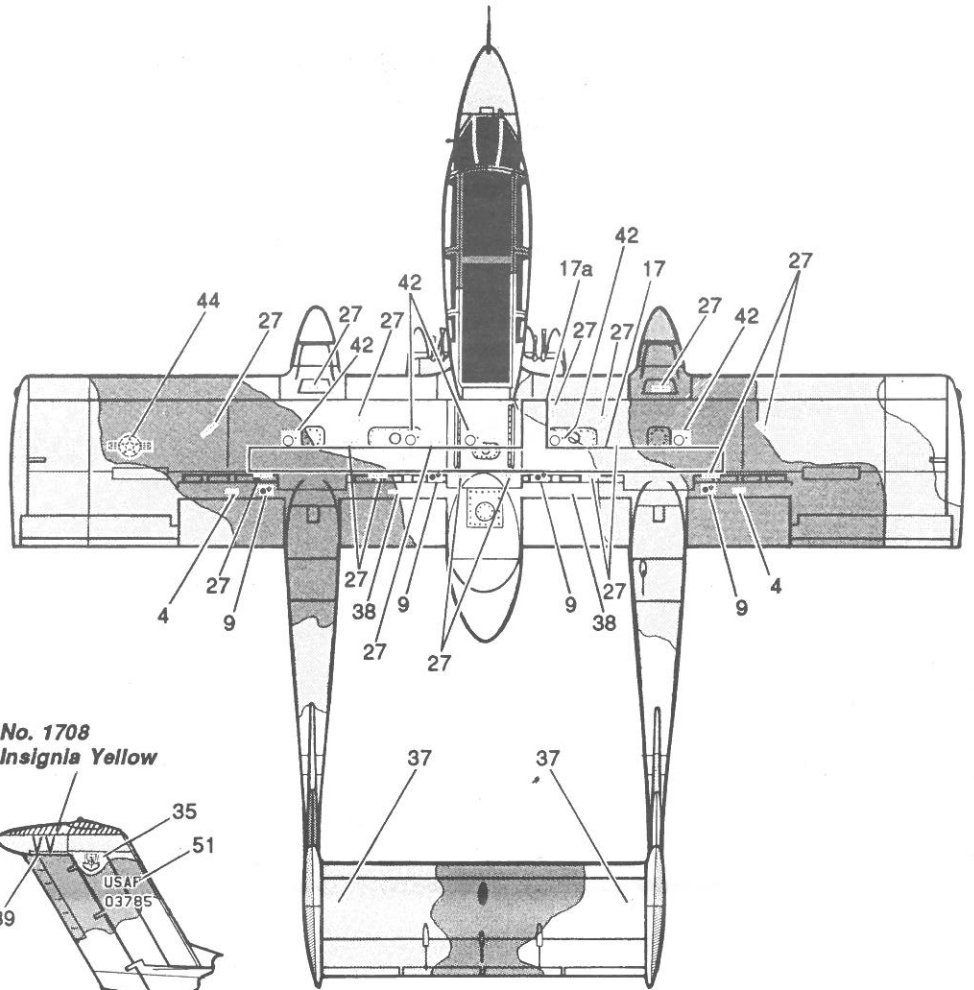

**ALTERNATE MARKINGS**

-  **No. 1708**  
 Insignia Yellow
-  **No. 1172**  
 Flat Sea Blue

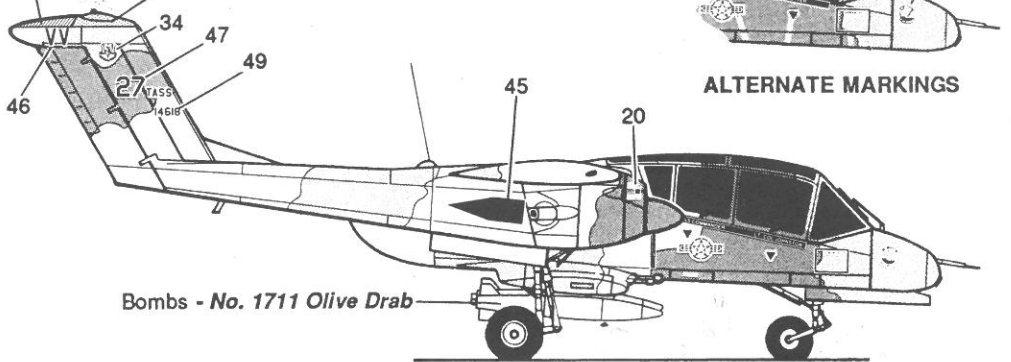

**ALTERNATE MARKINGS**

The numbers indicate decals.

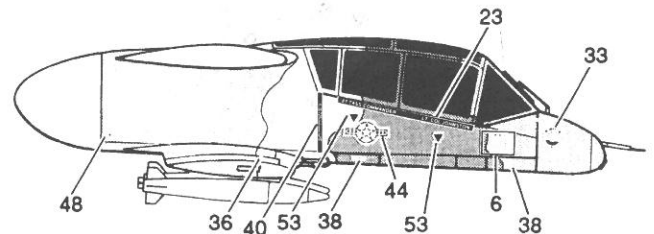

**APPLYING DECALS**

1. After carefully masking clear areas, spray entire model with Testor Glosscote #1261. Decals adhere best to a smooth surface and the shinier the finish the smoother it is. Allow the Glosscote to dry before going further.
2. Select the decals you plan to use and cut them from the decal sheet with scissors or a Testor Hobby Knife.
3. Working with only one decal at a time, dip the decal in clear water for no more than five seconds. Remove it from the water and place on a dry paper towel for about one minute.
4. When the decal slides easily on the backing paper, slide it to the edge of, and onto, the surface of the model with a soft Testor *Model Master* paint brush or tweezers. Remember the decals are very thin and can be easily ripped. Work slowly and carefully.
5. Once the decal is in the desired position apply a small amount of Testor Decal Set #8804. This will help the decal conform to any irregularities in the surface of the model. Allow the decal to dry undisturbed. Should you desire to purposely move it before it has dried, apply a little Decal Set to a soft brush and push the decal slowly into the desired position.
6. When the decals are completely dry (usually overnight), apply a coat of Testor Dullcote, #1260, to the entire model. This will give it an authentic, dull finish and protect the surface of the model. Now you can carefully remove the masking from the clear parts.



The numbers indicate decals.

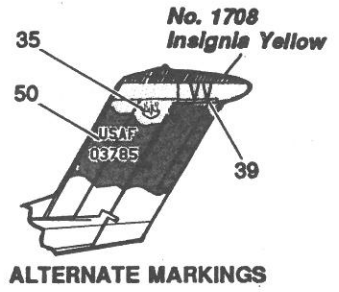
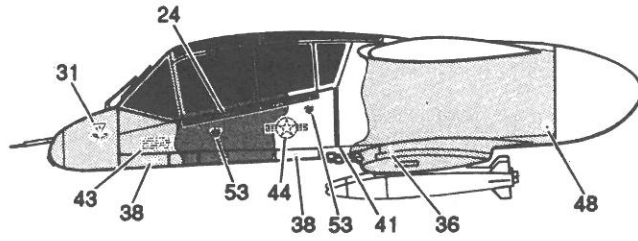

ALTERNATE MARKINGS

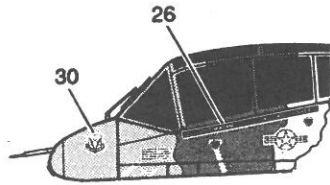

ALTERNATE MARKINGS

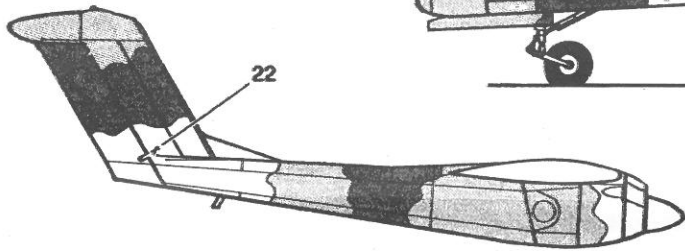
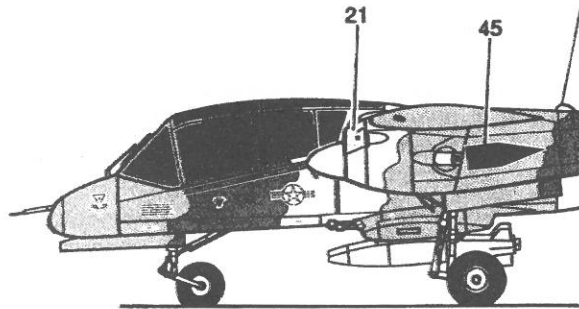
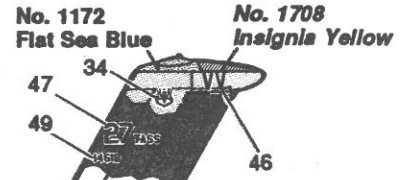

INBOARD LEFT BOOM

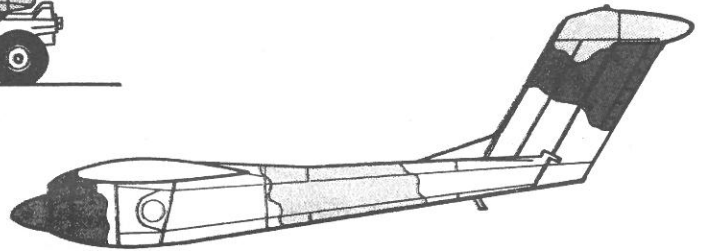

INBOARD RIGHT BOOM

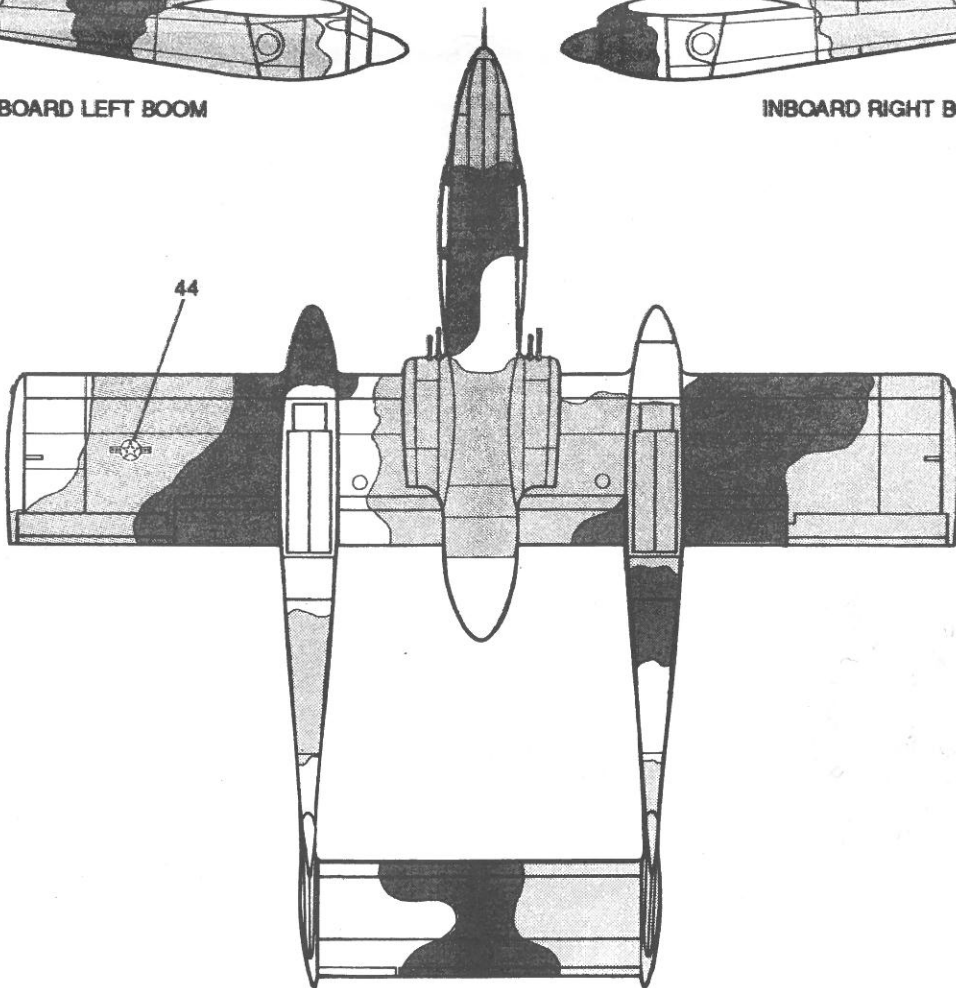

## WEATHERING HINTS

Nearly all military aircraft show some signs of wear. The process by which the modeler imparts this look to the model is referred to as **weathering**. Many times the weathering, that is, the representing on the model of soot, oil stains, or chipped paint, etc., can really make a model stand out and give it amazing authenticity.

After you have painted your model the proper colors, you can add the decals. If you first paint your model with Testor Glosscote, the decal carrier film will seem to disappear. Apply one or two coats of Glosscote for a smooth, glossy finish. Then, after this dries, apply the decals. This gives them a "painted on" look. If you want your model to have a matte finish, wait 24 hours for the decals to dry. Then spray on one or two coats of Testor Dullcote. When dry, you can begin weathering.

Always try to be logical in applying weathering techniques. For instance, you wouldn't want to put exhaust stains on a model and then apply a bright clean decal to the sooty area. Airplanes are normally well cared for, so they don't usually appear very battered. However, soot stains do tend to collect behind exhaust stacks and sometimes oil leaks onto the outside of the plane.

There are two methods of showing exhaust stains. The first is with an airbrush. This is a rather expensive item and requires practice to get the right effect. The second method is by using soft artist pastels or charcoal in shades of gray or black. Begin by grinding this material into a fine powder. Apply the powder to the model by rubbing it on with an old paint brush. Apply the color thicker and blacker near the exhaust outlet, and feather it out as it gets further away from the outlet. You should practice this on an old model or on a scrap of paper before trying it on your model. This technique is not very permanent, so it is a good idea to give your model a coat or two of Testor Dullcote to avoid rubbing off the stains.

Oil stains should be done very subtly. Oil really has very little color, so it only leaves light stains. Tint a small amount of thinner lightly with black paint. Add a small drop to the area you want to appear oily. Now with a strong breath, blow the "oil" back along the plane. Keep in mind the direction in which the planes flies, making sure you are blowing the "oil" from front to back. It is very easy to overdo this - one or two places are enough.

Paint chips are the simplest technique, but like the others, are easily overdone. An average military plane wouldn't have very many chips. They usually appear on the cutting edges of the propeller blades, the leading edges of wings and flying surfaces, and any areas where crew members or mechanics walk across the plane (i.e., wing roots). Use **No. 1781 Aluminum** for paint chips, applying with a fine pointed brush. With a very small amount of paint on the brush, apply the chips in small dots, the smaller the better. Large chips will look too obtrusive. Be wary of fabric covered control surfaces though; they don't chip.

Serious modelers collect books and photographs to use as reference when they finish their models. Your local hobby shop can help. Last, but certainly not least, your own observation will prove helpful. Visit museums and local airports, look at buildings and vehicles around you. Notice how rust streaks a metal roof. See the oil and dirt on a piece of road grading equipment. Study railroad boxcars and locomotives to see what the weather has done to them. Your own observation can be the best aid of all.

Remember: try not to overdo weathering - and **keep practicing**. Be patient, it takes time to discover and master all the tricks of this fascinating hobby.

## FIGURE PAINTING

Figures add dimension and life to your models. Painting figures is considered by many to be the most difficult aspect of modeling. However, if you are willing to take your time and practice, it can become the most rewarding.

After assembling your figure, it should be primed with a coat of Testor spray paint #1258 Flat White or airbrushed using Testor **Model Master No. 1768 Flat White**. It is nearly impossible to get proper coverage with a brush. Accessories may be glued on at this point, but this sometimes makes certain areas of the figure difficult to paint. It may be more convenient to paint these pieces separately and attach them to the finished figure.

When painting figures always use flat paints. A #0 brush with a fine point is best for painting figures. Smaller brushes do not hold enough paint. Put some Testor **Model Master No. 1742 Dark Tan** on a palette and mix in a little thinner so the paint flows smoothly off your brush. Apply an even coat over all the flesh areas. Now paint the eyes with **No. 1749 Flat Black**. These can be indicated by black slits, or if you wish, you can paint them as shown on the drawing. If they need shaping up, you can do this by painting around them with **No. 1742 Dark Tan**.

Begin shading by adding a very small amount of **No. 1785 Rust** with the **Dark Tan**. Fill in under the cheek bones and all areas indicated on the drawing. Proceed mixing progressively darker tones using **Dark Tan** and **Rust** until you finally use pure **Rust**. Use this color to outline all areas where the flesh meets the clothing (collar, cuffs, gloves, etc.). Finally, mix a small amount of #1183 Rubber with the **Rust** and paint fine lines in the mouth, nostrils, under eyebrows, inside ears and between fingers.

Add highlights by mixing **No. 1768 Flat White** with the **Dark Tan**. The drawing shows where these go. If you have any problems look at the photographs on the box.

Now begin shading the clothing. After the uniform is painted the proper color, hold the figure directly underneath a strong light. Notice where all the

shadows fall. Mix **No. 1749 Flat Black** with your uniform color and fill in these areas, carefully following the sculpted wrinkles on the figure. You can blend the color on the uniform to this shadow color by lightly moistening your clean brush with thinner and carefully going over where these colors meet.

After you are satisfied with the shadows, hold the figure under the light once again. Notice the areas where the light hits the strongest. Mix a little **No. 1768 Flat White** with the uniform color and carefully apply the highlights to these areas. Remember, the shadows occur *under* the folds and the highlights occur *on top* of the folds. Finally, you can outline all straps, belts, pockets, collars, and edges of clothing with a thin wash of **No. 1749 Flat Black**.

Observe real faces and clothing and notice how the light falls on them. Adapt these ideas to your figures, try to make them as realistic as possible. You can also learn a lot from studying other people's figures. Don't be too subtle in your shading - contrast is what gives figures life.

Practice and experience are the best teachers, so don't get discouraged if you aren't pleased with your first attempts. Always take your time and strive for a neat, crisp appearance. Have patience. It takes time to learn a new skill and it's worth it!

# TESTOR OFFERS A FULL LINE OF THE WORLD'S FINEST KITS... AND MAKES THEM EVEN BETTER

**Armored Tanks from Italy  
WWII Aircraft from France  
Exotic Sports Cars from Japan  
Modern Jets from the U.S.A.**

Our designers travel extensively in search of the most exciting, crisply-tooled subjects the world's top manufacturers have to offer. Models that appeal to all kinds of builders. Classic 1930s automobiles like the '33 Chrysler Dual-Cowl Phaeton; exotic sports cars like the new Porsche 959; famous aircraft including unique prop-driven planes like the Lockheed C-119; jets like the SR-71 Blackbird; modern armor and diorama accessories. Even aircraft carriers and cable cars.

**WE MAKE THEM BETTER—  
Easy and thorough instructions**

We rewrite the instructions—turning confusing, single-page drawings into four, eight, and sometimes sixteen-page English language booklets. Each includes tips written by the professionals on weathering and other finishing techniques. There are no instructions more comprehensive than ours.

**WE MAKE THEM BETTER—  
Professional quality decals**

We research and produce the industry's finest decals. Thin, precisely registered, and easy-to-apply. (Gathering the documents needed to design authentic markings often takes months.) Many Testor kits offer alternate markings as yet another option.

**WE MAKE THEM BETTER—  
Colorful and informative packaging**

Finally, our plastic models are packaged in colorful boxes with photos and resource material on all six sides. Profile notes, special features, close-up detail shots of the actual finished kit, and a list of all required paints and modeling supplies enhance each outside panel.

We are proud of Testor model kits... and of our Model Master paints, artist-quality brushes, hobby tools, and cements. You cannot buy better hobby accessories or finishing supplies. Anywhere.

The Testor Corporation  
620 Buckbee Street  
Rockford, IL 61108



# What Do Aztek Airbrushes and the Stealth Fighter Have in Common?

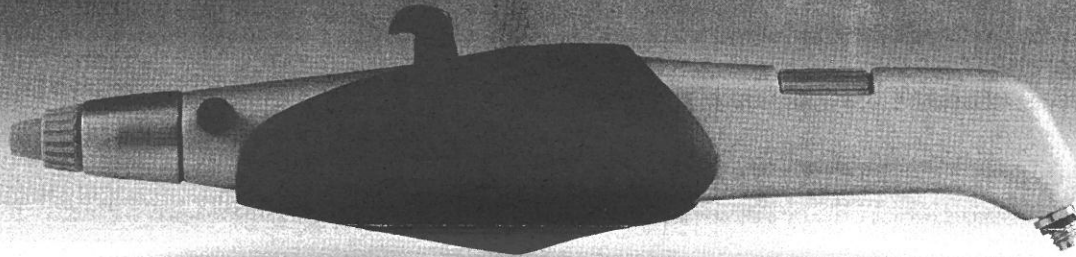

## Advanced Technology

### Both deliver top performance.

Aztek Airbrushes are designed as an extension of the artist's hand, much like the Stealth Fighter is an extension of the pilot's hand. The trigger on an Aztek gives extremely precise control by allowing relatively large trigger travel for small needle movement. Lightweight and easy to hold, Aztek delivers fine detail with pinpoint accuracy.



*The patented Aztek nozzle replaces hard to adjust needles*

### Both are designed to be responsive.

Unlike other airbrushes, the Aztek system uses uniquely engineered, durable, self-contained nozzles for quick and easy changes among spray patterns. No more easily damaged needles! With nine interchangeable nozzles

and nine interchangeable color cups and jars, you can get over 50 different airbrushes in one. And our advanced nozzle and body design are so easy to clean that you concentrate on airbrushing, rather than time-consuming disassembly.

### Both are made of strong, lightweight, space-age composite materials.

Built of an acetal resin copolymer, Aztek Airbrushes are nearly unbreakable, yet are significantly lighter than their metal predecessors. Aztek Airbrushes are built significantly better, due to the higher manufacturing tolerances achieved with this remarkable material.

Aztek Airbrushes, like the Stealth Fighter, are the result of innovative

thinking. Put under the test, each Aztek proves the significance of its advanced engineering. See for yourself why Aztek Airbrushes are simply better. Visit your local airbrush dealer today.

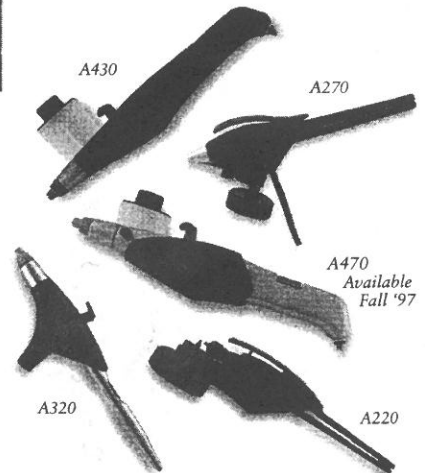

*A470 Available Fall '97*

The Testor Corporation

620 Blackhawk Park Avenue, Rockford, IL 61104

1-800-962-6654



An **FEM** Company

©1997 The Testor Corporation

Visit Us on the Web at [www.testors.com](http://www.testors.com)



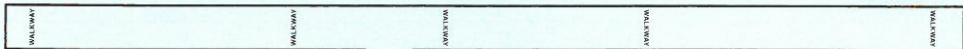

17A [ ] 23 **27 TASS COMMANDER** LT. COL JOHNSTON

2 [ ] 24 **DCC SGT T TURNER** ACC AMN C SHOUSE

1 [ ] 25 **LT HICKEY** LT RUTTER

3 [ ] 26 **DCC SSGT McADAMS** ACC A/C FISHER

4 [ ] 27 NO STEP NO STEP NO STEP NO STEP

5 [ ] 27 NO STEP NO STEP NO STEP NO STEP

6 [ ] 27 NO STEP NO STEP NO STEP NO STEP

7 [ ] 27 NO STEP NO STEP NO STEP NO STEP

8 **DANGER EXHAUST** 9 [ ]

10 [ ]

11 [ ]

12 **55483**

13 **MARINES**

14 **OV-10A 155483**

15 **RESCUE** →

16 ← **RESCUE**

17 **55483**

18 [ ]

19 [ ]

20 [ ]

21 [ ]

22 [ ]

23 [ ]

24 [ ]

25 [ ]

26 [ ]

27 [ ]

28 [ ]

29 [ ]

30 [ ]

31 [ ]

32 [ ]

33 [ ]

34 [ ]

35 [ ]

36 [ ]

37 [ ]

38 [ ]

39 **VV VV**

40 [ ]

41 [ ]

42 [ ]

43 [ ]

44 [ ]

45 [ ]

46 **VV VV**

47 **27 TASS** L

48 [ ]

49 [ ]

50 **USAF 03785**

51 **USAF 03785**

52 [ ]

53 [ ]

54 [ ]

55 [ ]

56 [ ]

57 [ ]

58 [ ]

59 [ ]

60 [ ]

61 [ ]

62 [ ]

63 [ ]

64 [ ]

65 [ ]

66 [ ]

67 [ ]

68 [ ]

69 [ ]

70 [ ]

71 [ ]

72 [ ]

73 [ ]

74 [ ]

75 [ ]

76 [ ]

77 [ ]

78 [ ]

79 [ ]

80 [ ]

81 [ ]

82 [ ]

83 [ ]

84 [ ]

85 [ ]

86 [ ]

87 [ ]

88 [ ]

89 [ ]

90 [ ]

91 [ ]

92 [ ]

93 [ ]

94 [ ]

95 [ ]

96 [ ]

97 [ ]

98 [ ]

99 [ ]

100 [ ]

CLEAR WHITE LT BU LIF YFI LOW REDDK RI LIF GRAY RI ACK