

Hawker Tempest Mk II/F.2

Historie

Hawker Tempest (v angličtině bouře) byl velmi výkonným britským jednomotorovým stíhacím letounem druhé světové války. První sériový Tempest Mk.V (JN729) byl zalétán 21. června 1943. Již od počátku výroby byly Mk.V vybaveny kapkovitým krytem kabiny a čtyřadvacetiválcovým řadovým motorem Napier Sabre IIA o vzletovém výkonu 1603 kW. Prvních sto kusů Mk.V Series 1 bylo vyzbrojeno čtveřicí kanónů British Hispano Mk.II instalovaných v křídle, jejichž hlavně o 0,2 m přesahovaly náběžnou hranu. Další Tempesty Mk.V Series 2 obdržely kanóny Hispano Mk.V s kratší hlavní. Tempesty byly poprvé bojově nasazeny začátkem května 1944 nad Francií při útocích na dopravní systém a letiště. Letadla Tempest aspirovala díky své rychlosti i ostatním vlastnostem na titul nejlepší stíhačky Royal Air Force.

Další sériově vyráběnou verzí Tempestu se stala verze Mk.II s hvězdicovým motorem Centaurus. První ze dvou prototypů Tempest II vzletl v červnu 1943 následován druhým prototypem v září. Celkem bylo vyrobeno 457 kusů verze Mk.II/F.2.

History

The Hawker Tempest was a very powerful British single-engine fighter aircraft of World War II. The first serial Tempest Mk.V (JN729) was flown on June 21, 1943. From the beginning of production, the Mk.V were equipped with a teardrop-shaped cabin cover and a twenty-four-cylinder inline engine Napier Saber IIA with a takeoff power of 1603 kW. The first hundred pieces of the Mk.V Series 1 were armed with four British Hispano Mk.II cannons installed in the wing, whose barrel by 0.2 m exceeded the leading edge. Other Tempesty Mk.V Series 2 received Hispano Mk.V cannons with a shorter barrel. Tempests were first deployed in combat in early May 1944 over France during attacks on the transport system and airports. Thanks to its speed and other characteristics, Tempest aircraft aspired to the title of the best Royal Air Force fighter.

Another mass-produced version of the Tempest became the Mk.II version with a Centaurus star engine. The first of two Tempest II prototypes took off in June 1943, followed by a second prototype in September. A total of 457 pieces of the Mk.II / F.2 version were produced.



OPTIONAL
VOLITELNÉ



DRILL HOLE
VYVRTAT



SYMMETRICAL
SYMETRICKY



REMOVE
ODSTRANIT

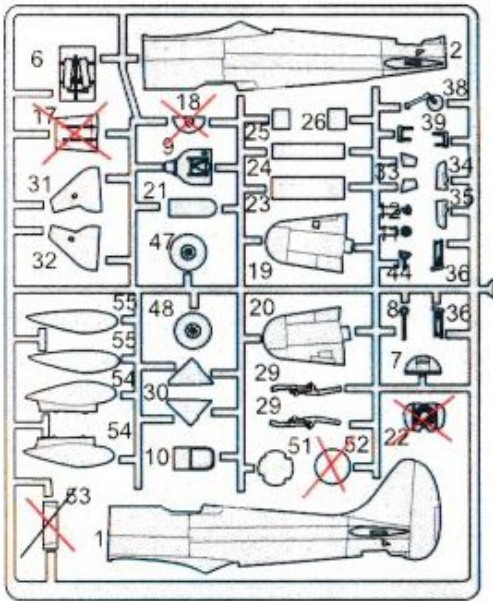

Plastikové díly/
Plastic parts

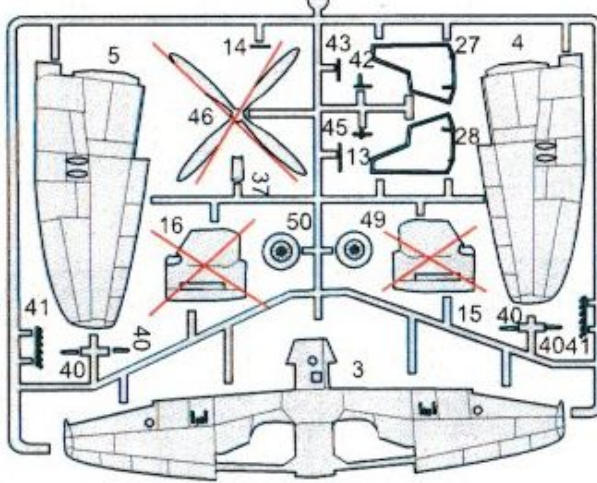

Průhledné díly/
Clear parts

- C1
- C2
- C3
- C4

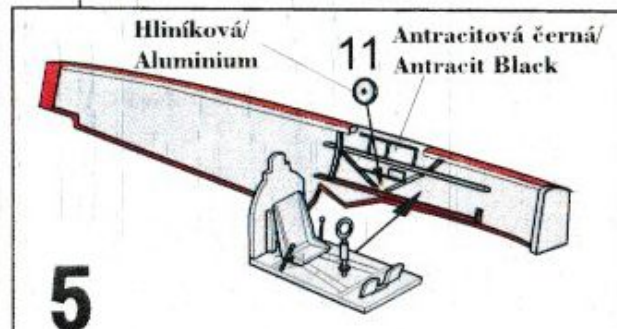
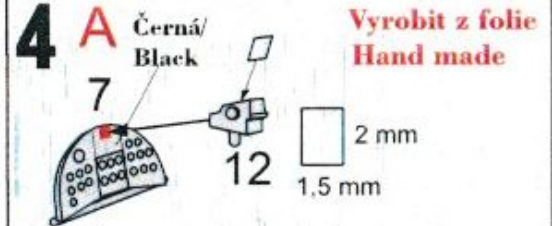
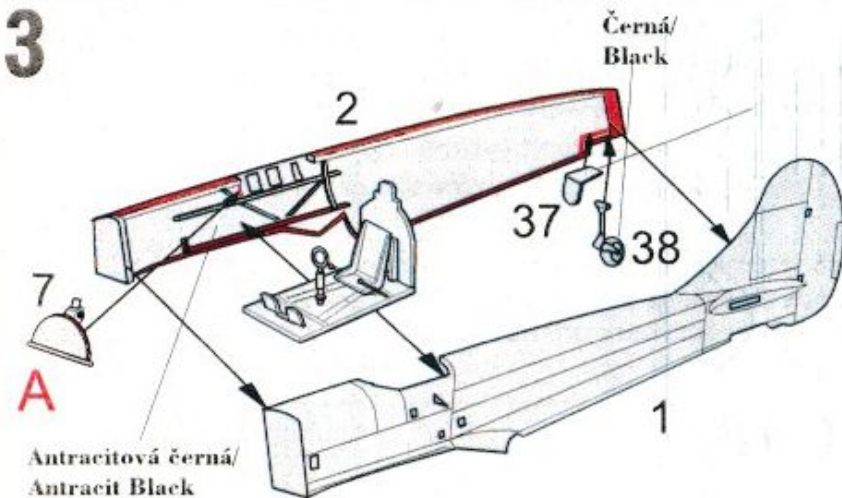
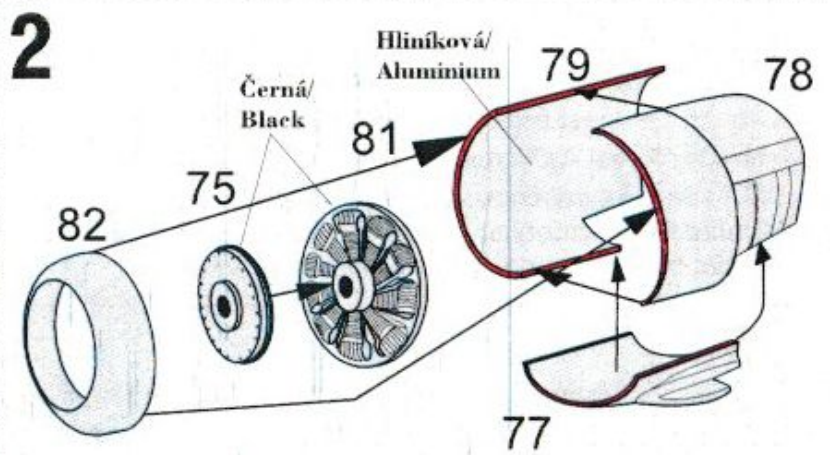
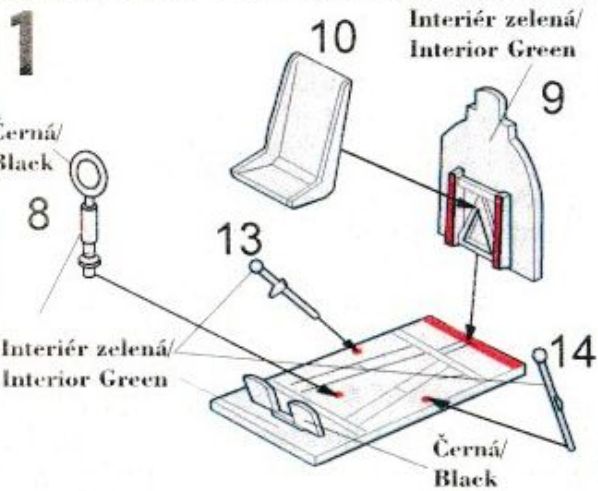
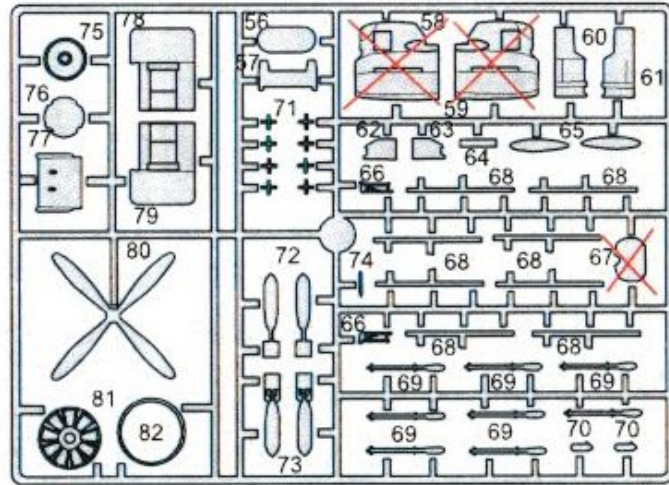

6

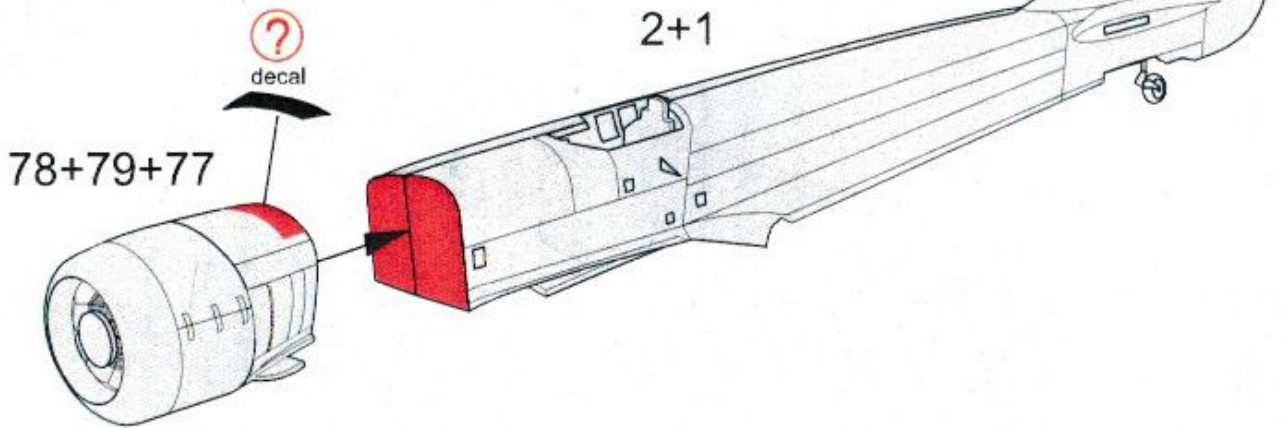

8

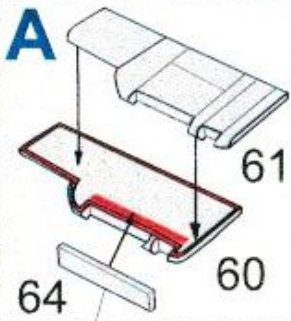

Černá/
Black

A 7

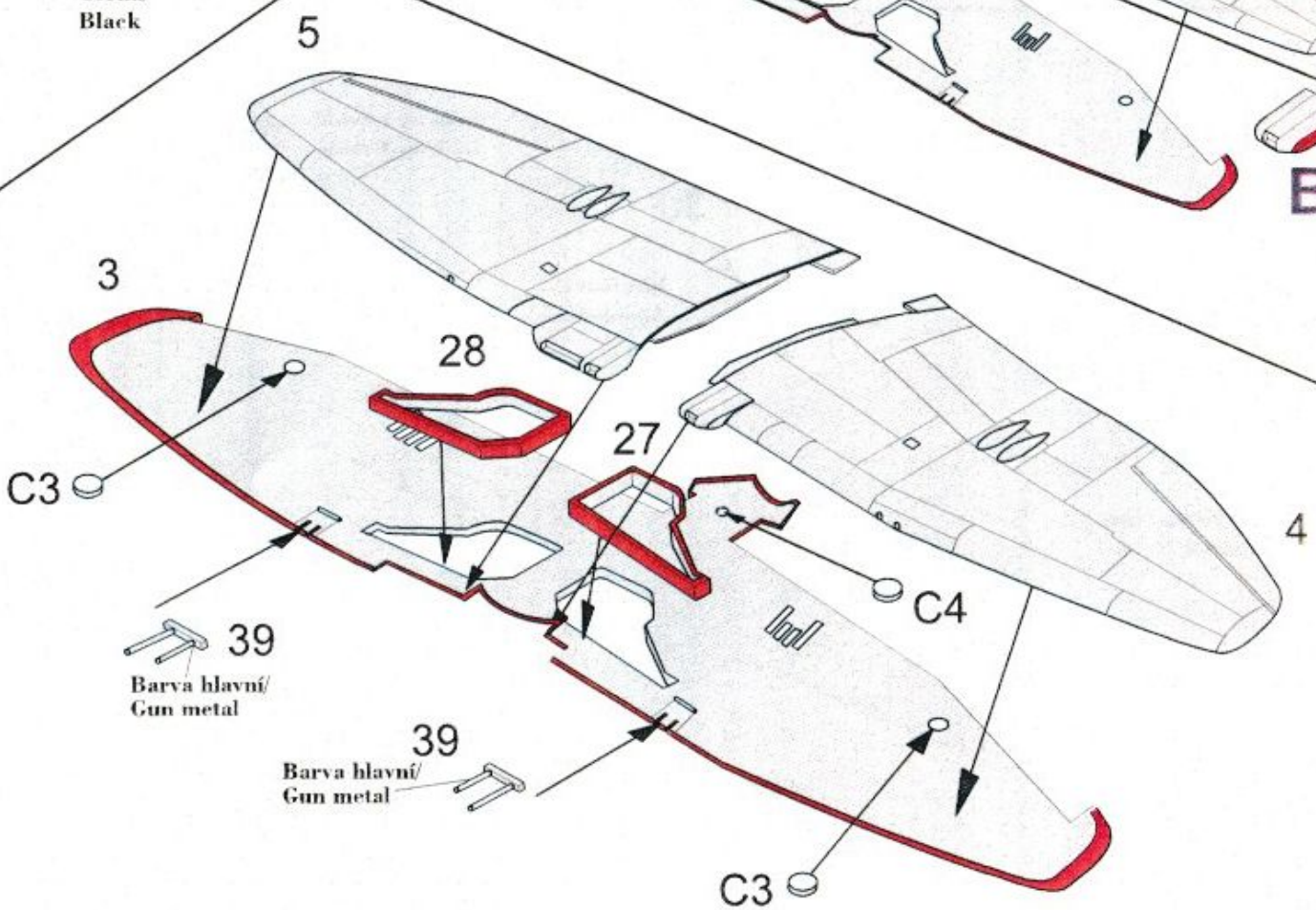
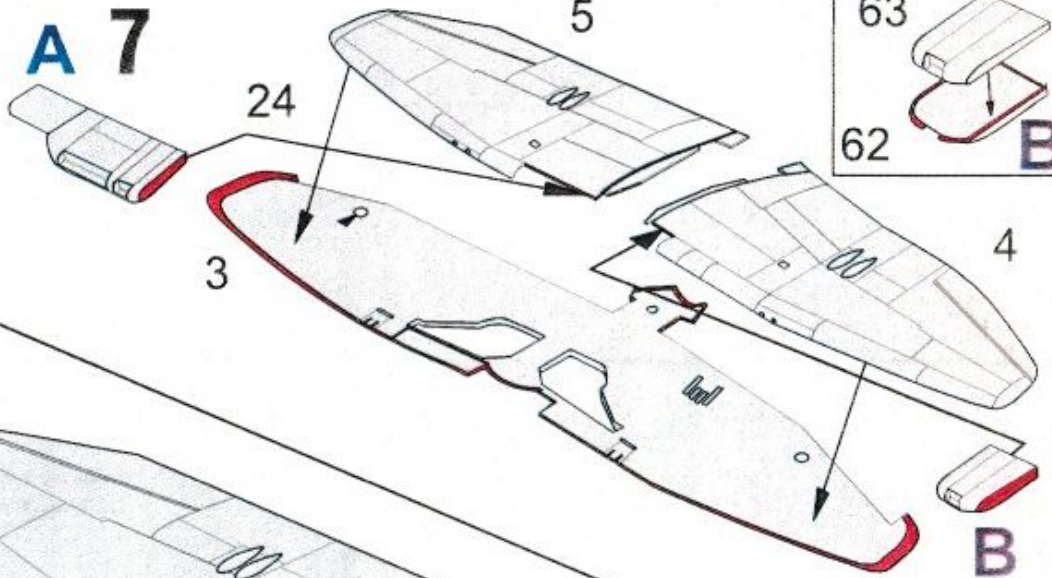

9

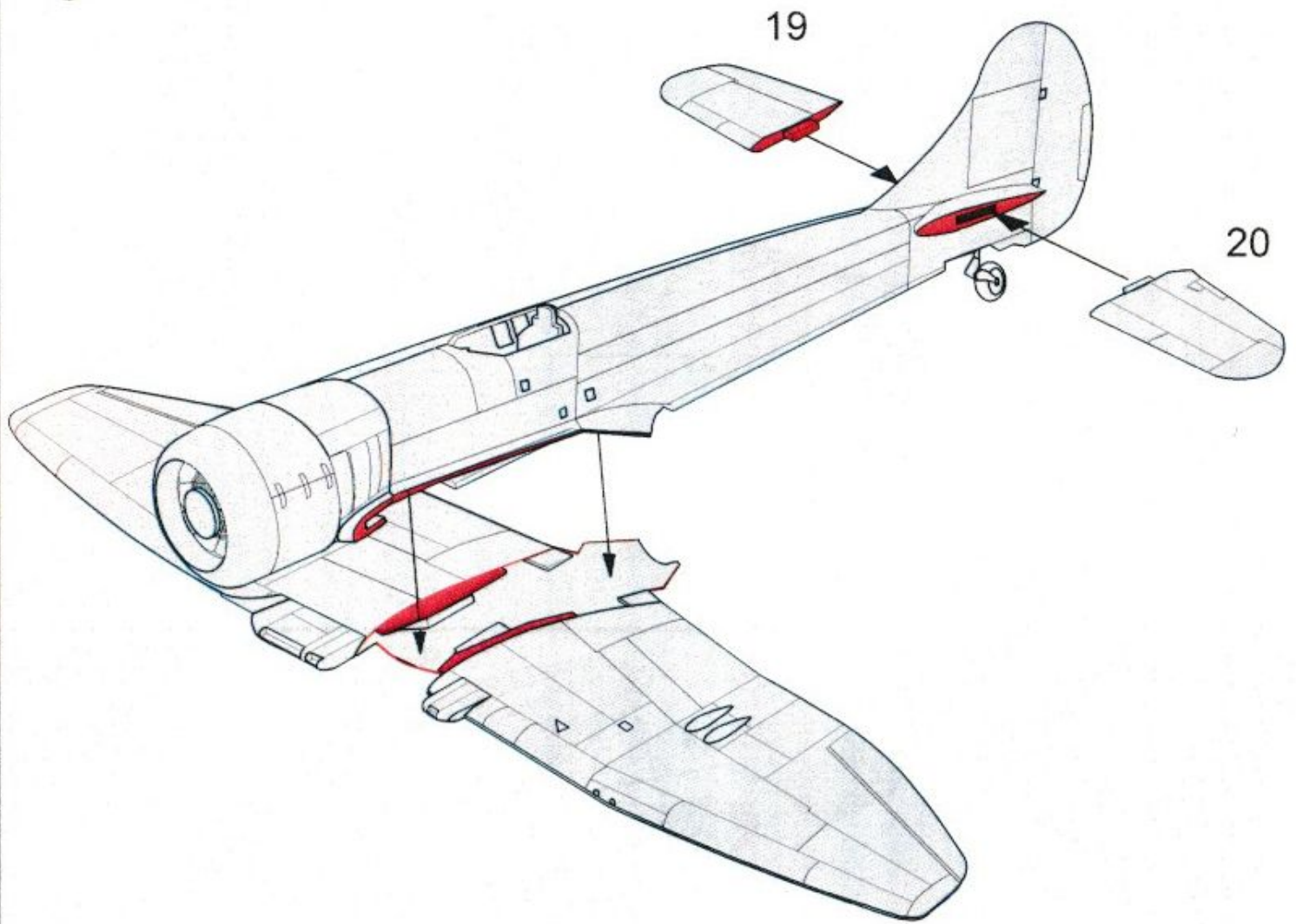

10

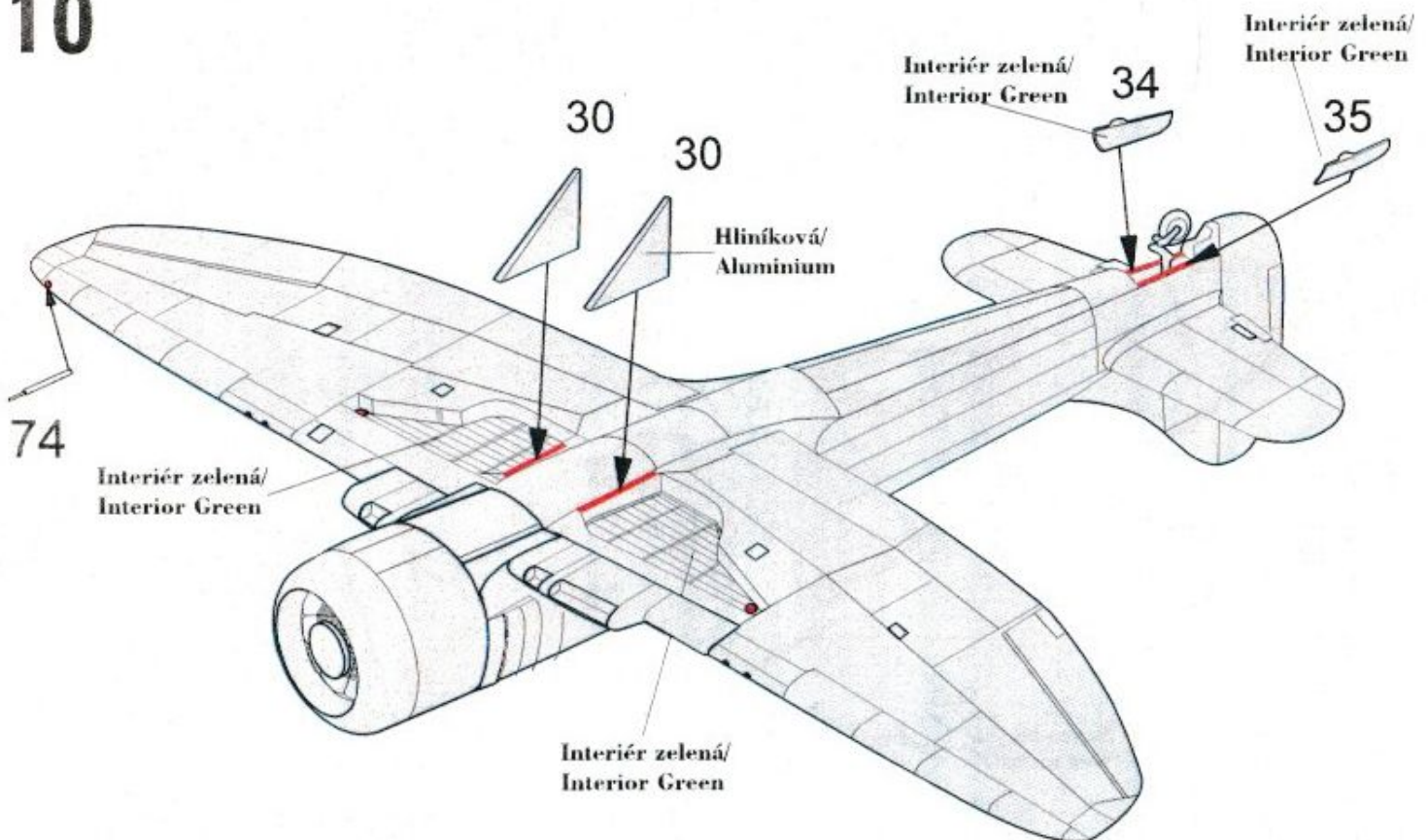

11

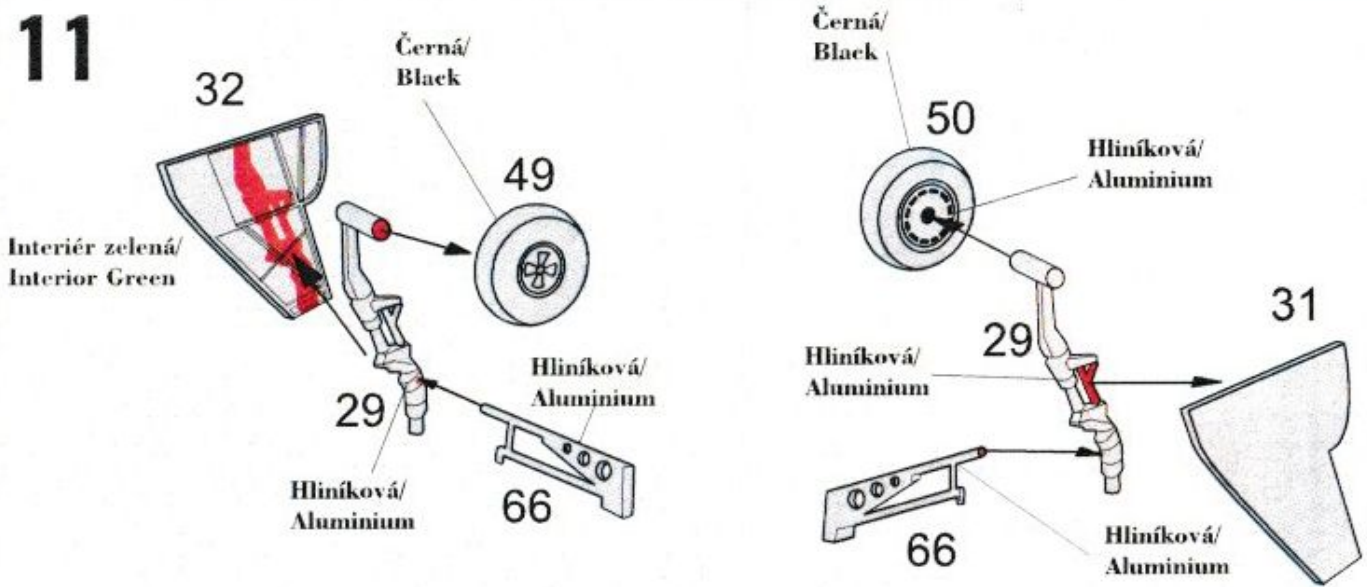

12

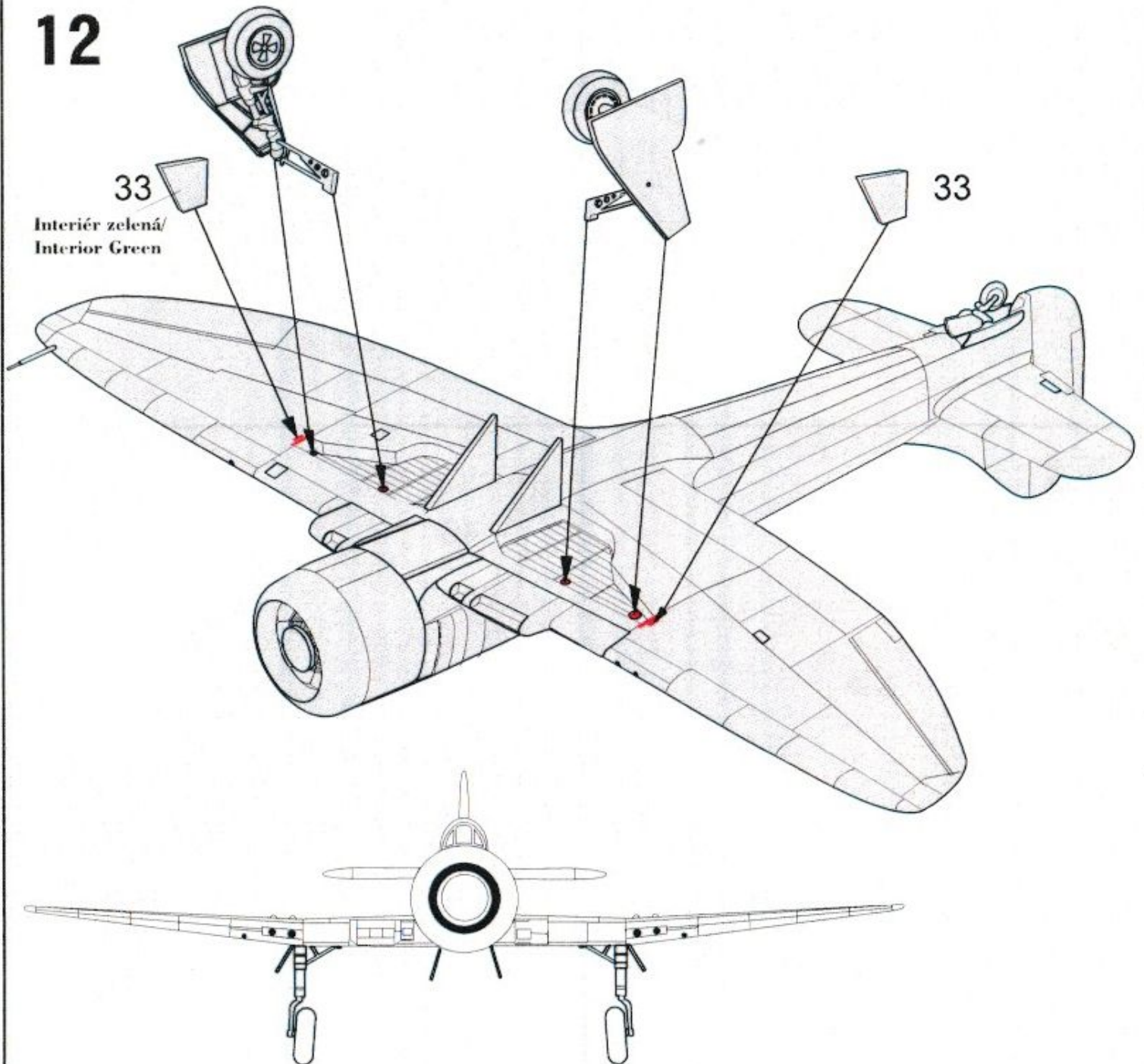

13

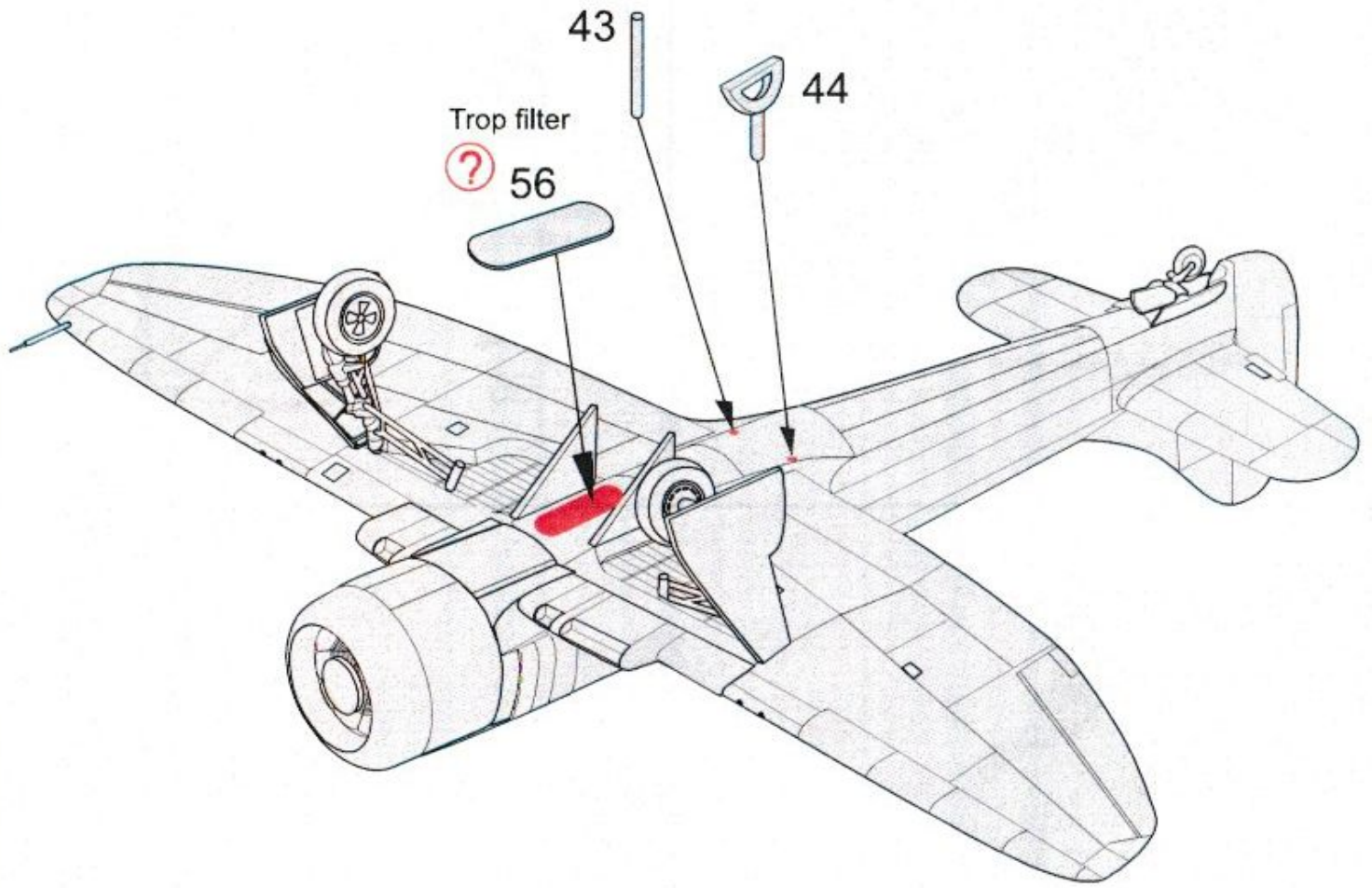

14

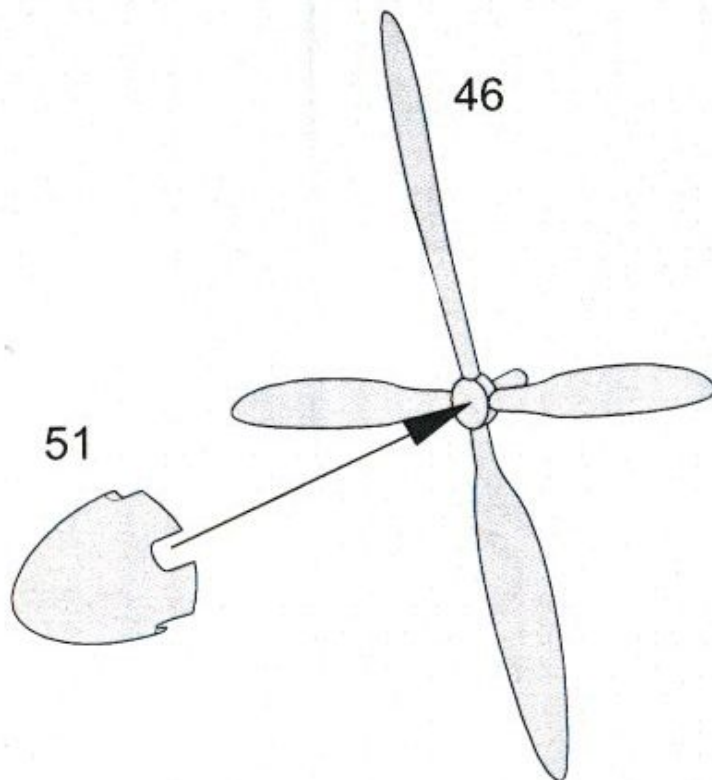

15

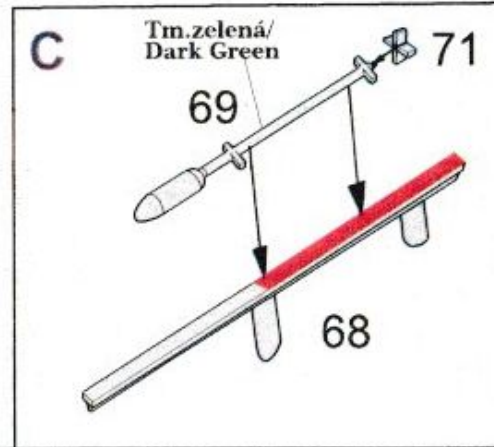
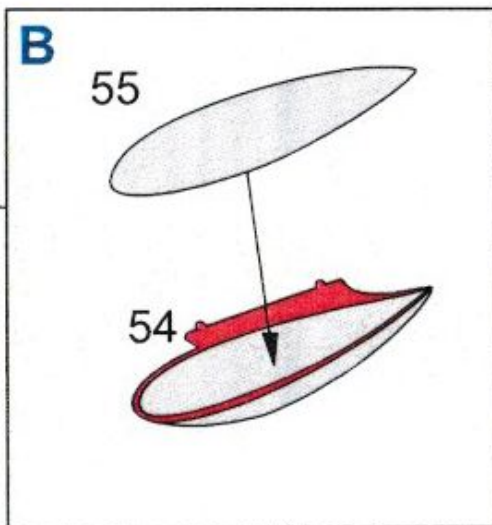
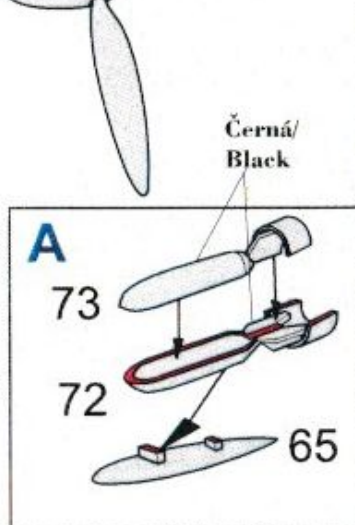
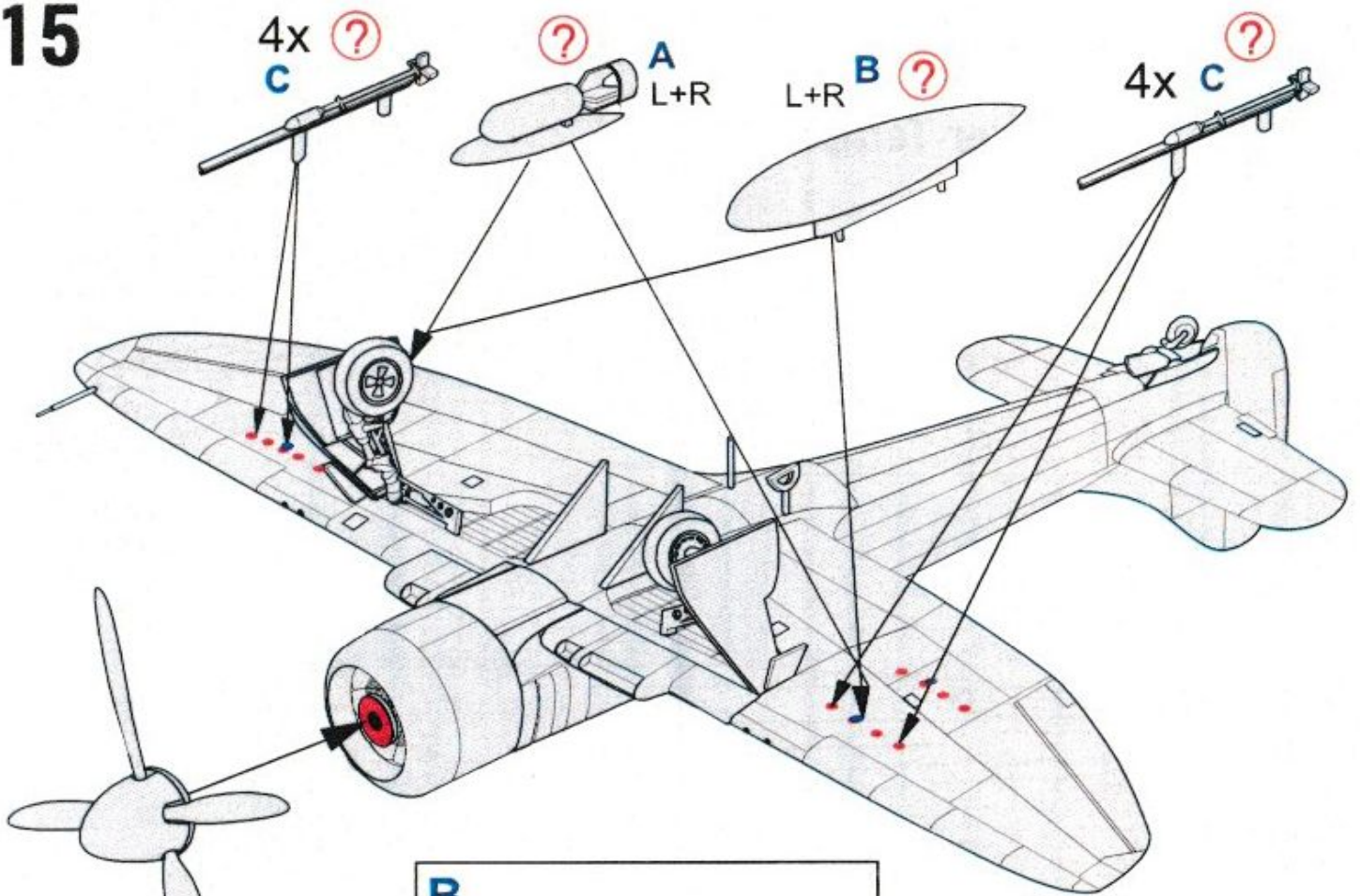

16

C1+C2

Žlutá/
Yellow

70 70

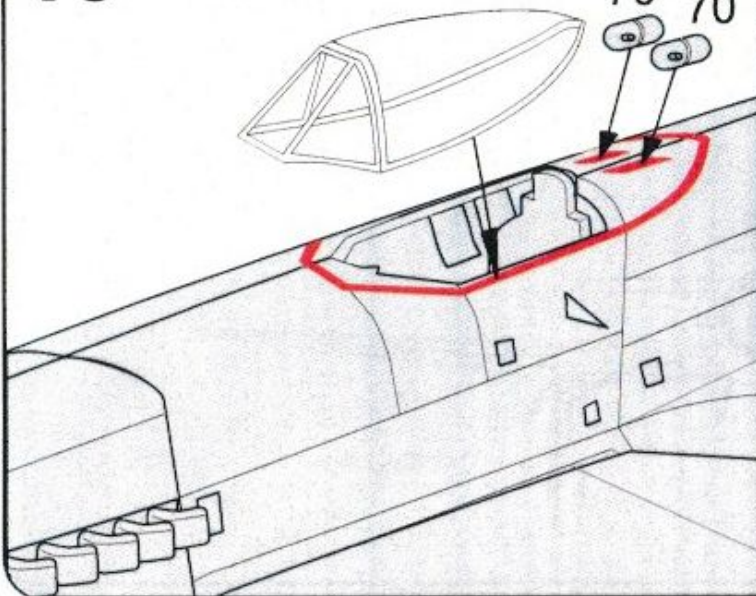

17

C1

C2

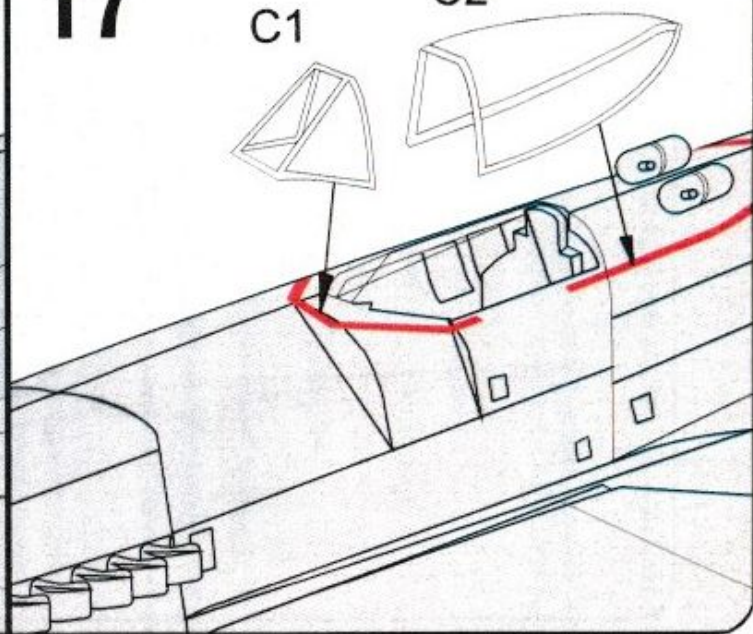

18

Hawker Tempest F.2

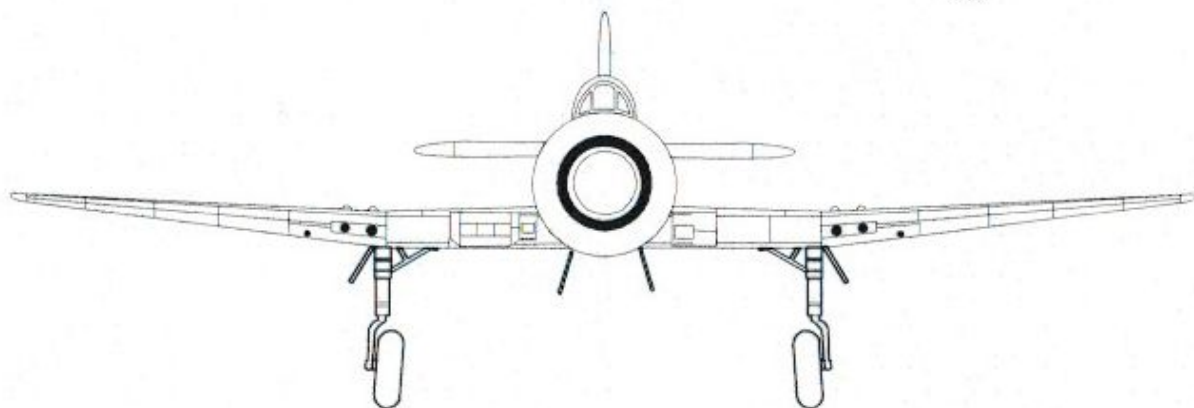
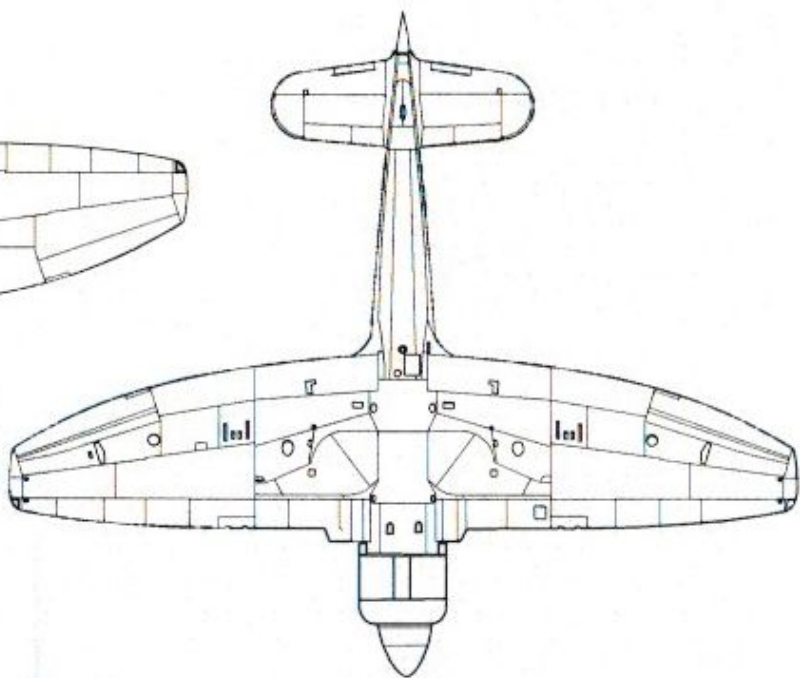
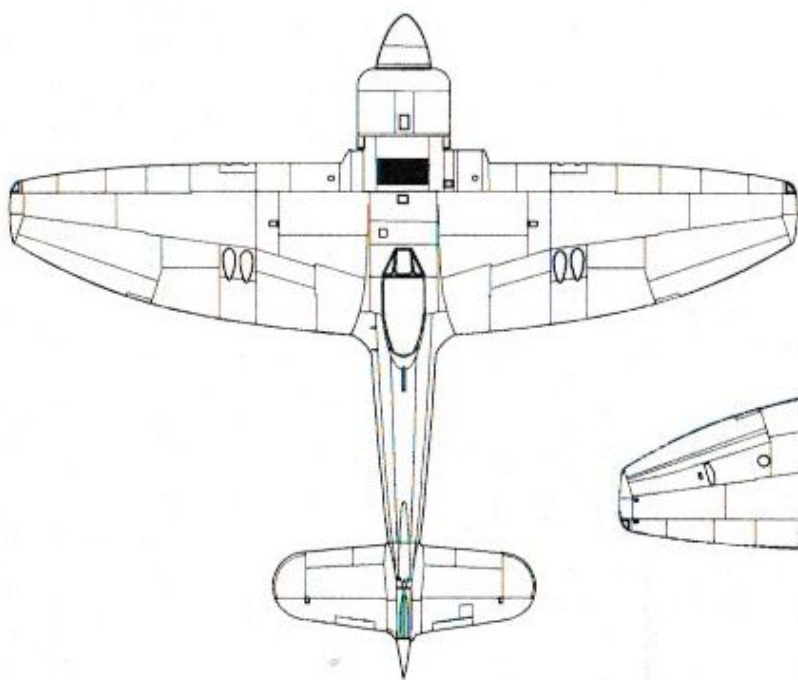
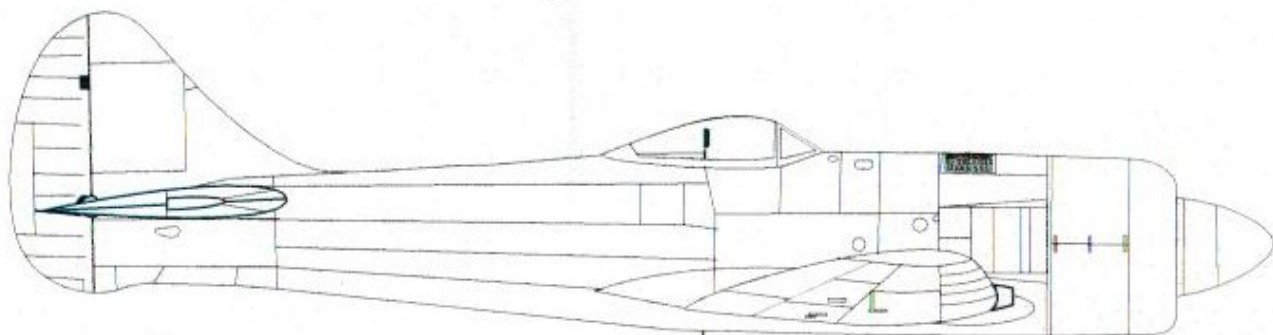
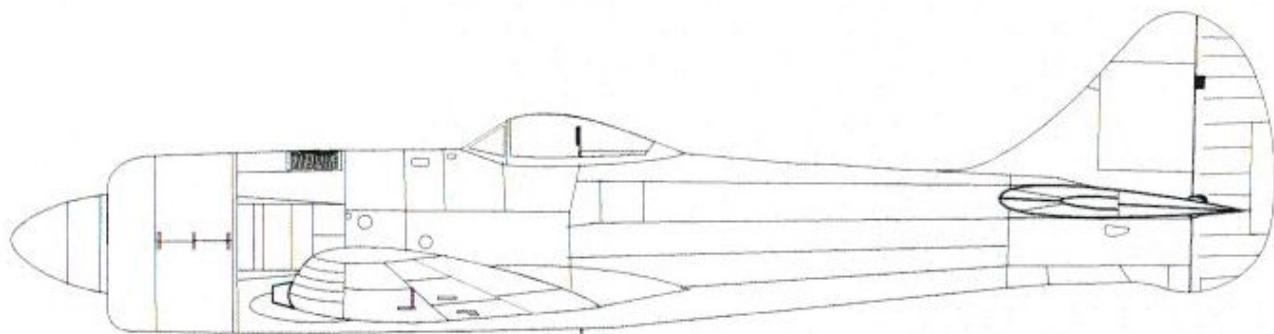

1

Hawker Tempest F.2, PR 674, pilot Wg.Cdr. F.R. Carey, Fasberg 1948.
Hawker Tempest F.2, PR 674, flown by Wg.Cdr. F.R. Carey, Fasberg 1948.

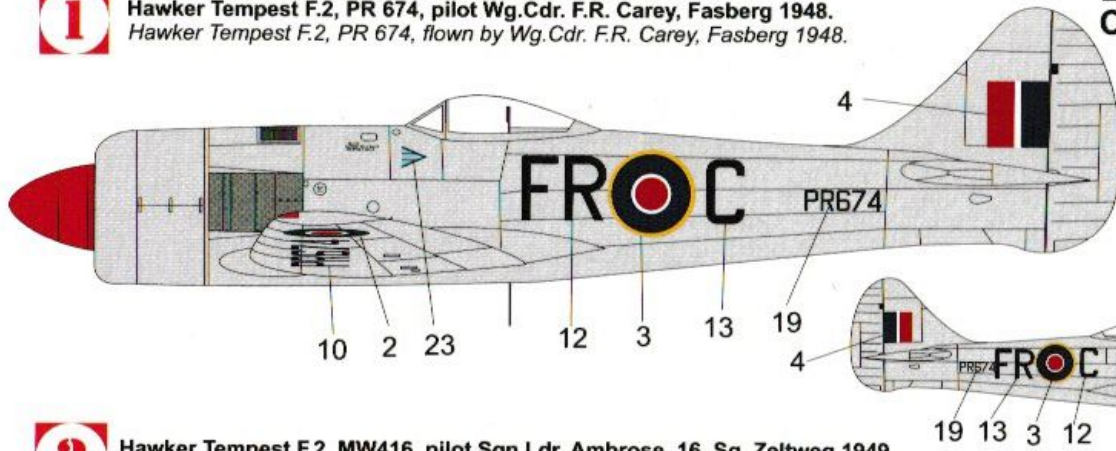

Zbarvení & Označení
Colours & Markings

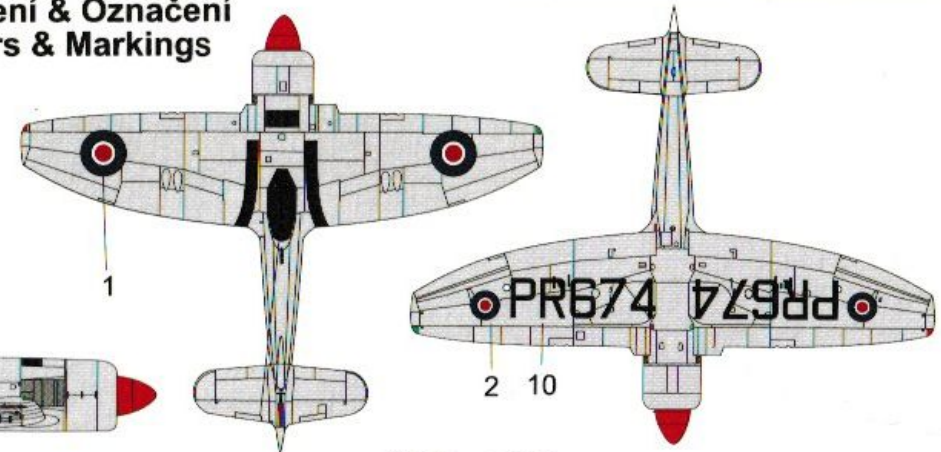

2

Hawker Tempest F.2, MW416, pilot Sqn.Ldr. Ambrose, 16. Sq, Zeltweg 1949.
Hawker Tempest F.2, MW416, flown by Sqn.Ldr. Ambrose, 16. Sq, Zeltweg 1949.

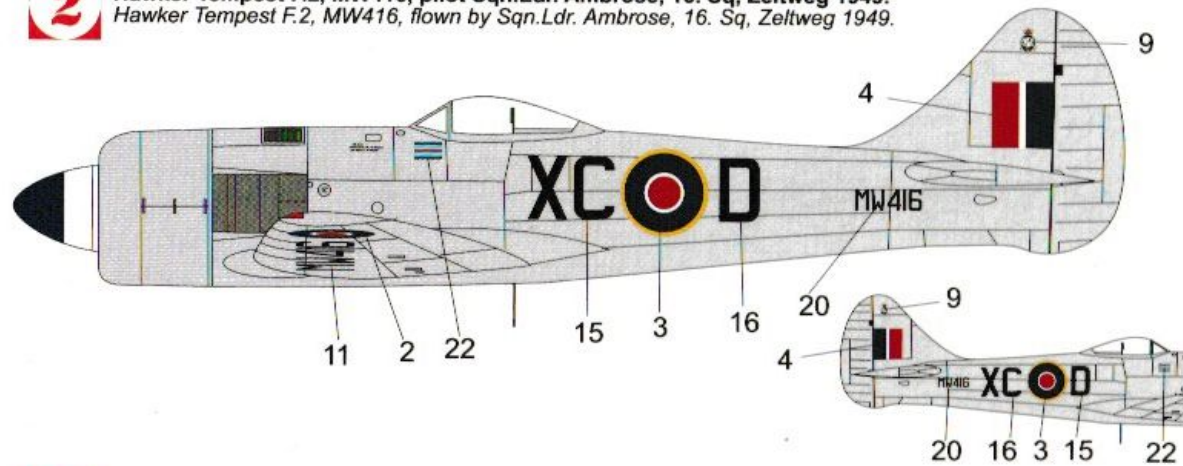

Hliník Aluminium
Černá Black

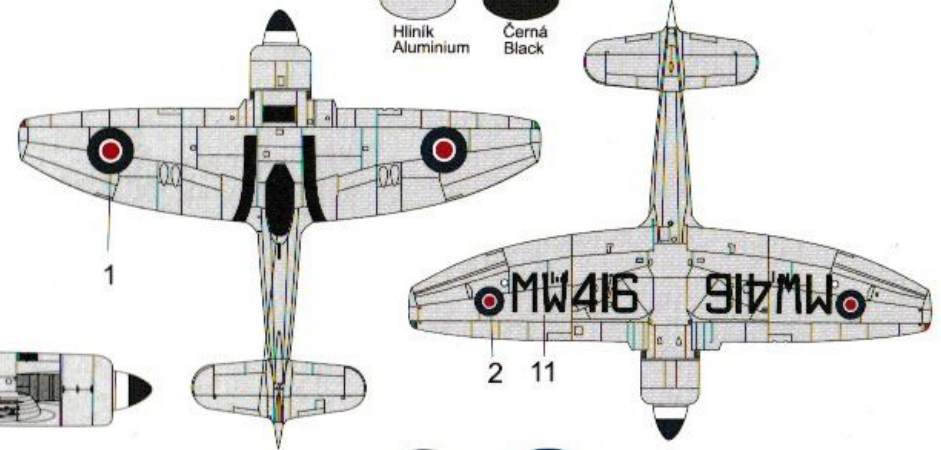

3

Hawker Tempest F.2, PR 533, 33. squadrona, RAF, Kuala Lumpur, Malajsie 1949.
Hawker Tempest F.2, PR 533, of 33. squadron, RAF, Kuala Lumpur, Malaya 1949.

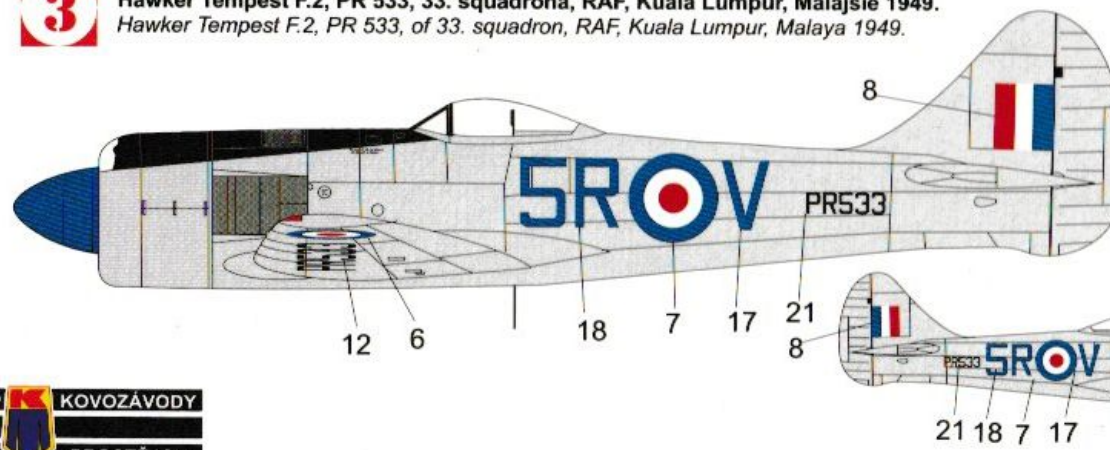

Tmavě modrá Dark Blue
Modrá Blue

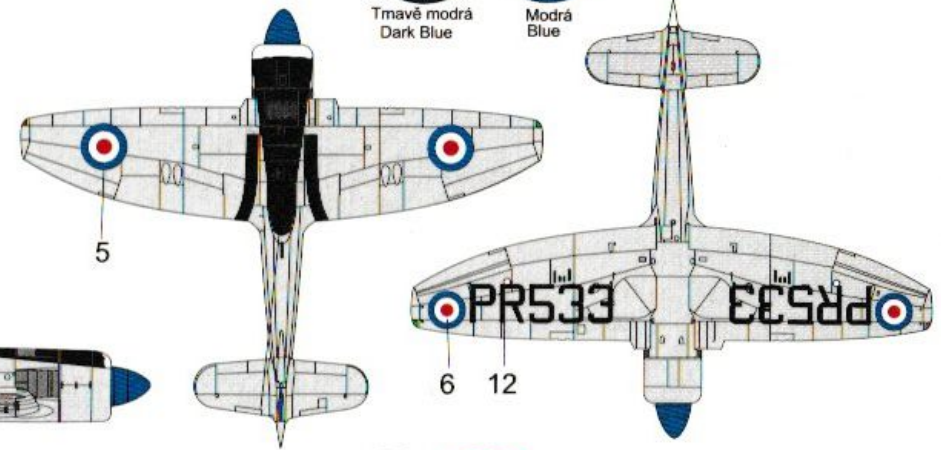

Bílá White
Červená Red