

JUNKERS J.2

RSSH - 72010

HOBBS
Scale Scratchbuilt Hobby

The Junkers J.2 (E-2) was the first all-metal aircraft intended as a dedicated military aircraft design; the first all-metal aircraft meant to be a fighter aircraft and was the direct descendant of the pioneering J.1 all-metal aircraft technology demonstrator design of 1915.

The first production example of the J.2, (serial number E.250/16) was delivered to Adlershof on 2 July 1916 and started its static load testing. A short time later, IDFLIEG test pilots began performing full flight evaluation tests on the six examples of the J.2. Later in the summer of 1916 Max Schade take one of the test aircraft on a flight from Berlin to Dessau and achieve with the aircraft a speed of 180 kilometers per hour (110 mph), which was some 16 kilometers per hour (9.9 mph) faster than the contemporary French Nieuport 11. But test aircrafts still failed rate of climb tests when compared with wooden structures designs. Junkers J.2 steel structure made it too heavy to participate in dogfights over the front.

Six aircraft built.

Crew: 1

Length: 7.3 m

Wingspan: 11.0 m

Wing area: 19.84 m²

Empty weight: 865 kg

Gross weight: 1060 kg

Power plant: 1 × Mercedes D II (88kW)

Maximum speed: 170 km/h

Armament: 1 × 7.92 mm IMG 08 Spandau machine gun

Thanks for your interest in this model.

rss.hobbis@gmail.com

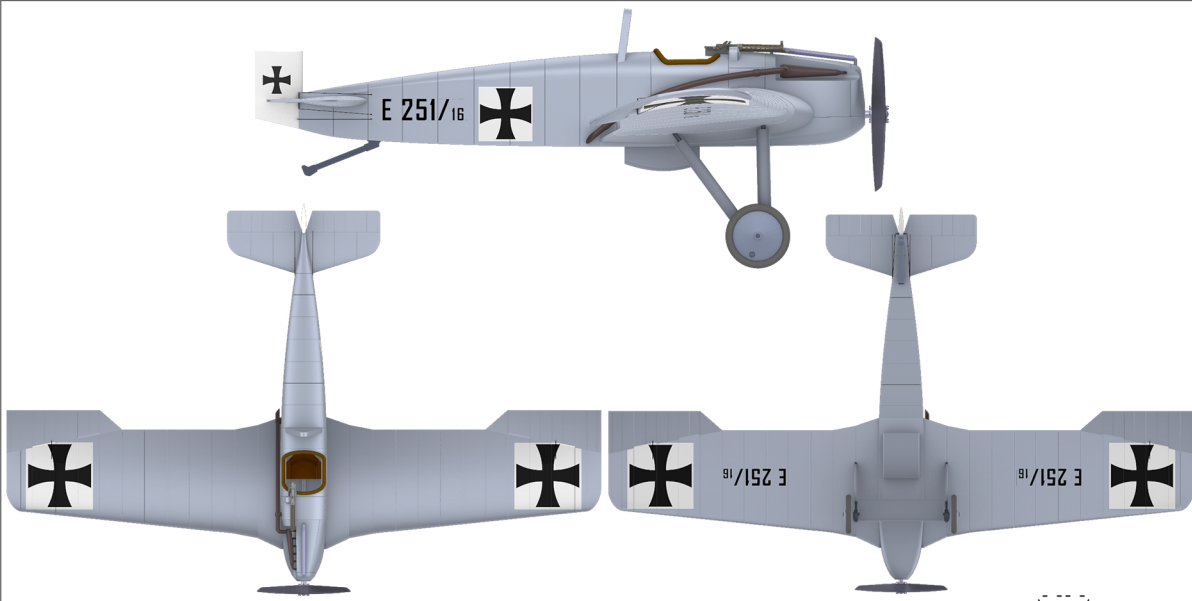

Painting:

All - bare metal

Rudder - white

Letters & numbers - black

Decals:

White images + complete drying + black images



JUNKERS J.2

RSSH - 72010

HBBIS
Scale Scratchbuilt Hobby

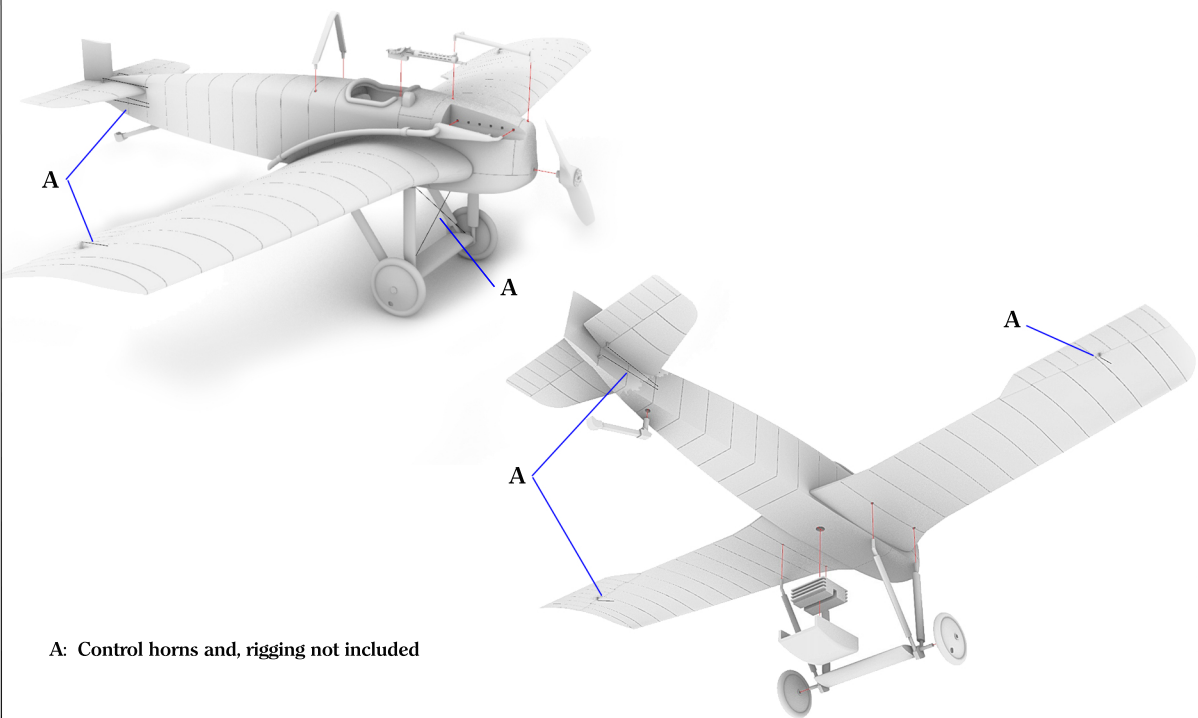
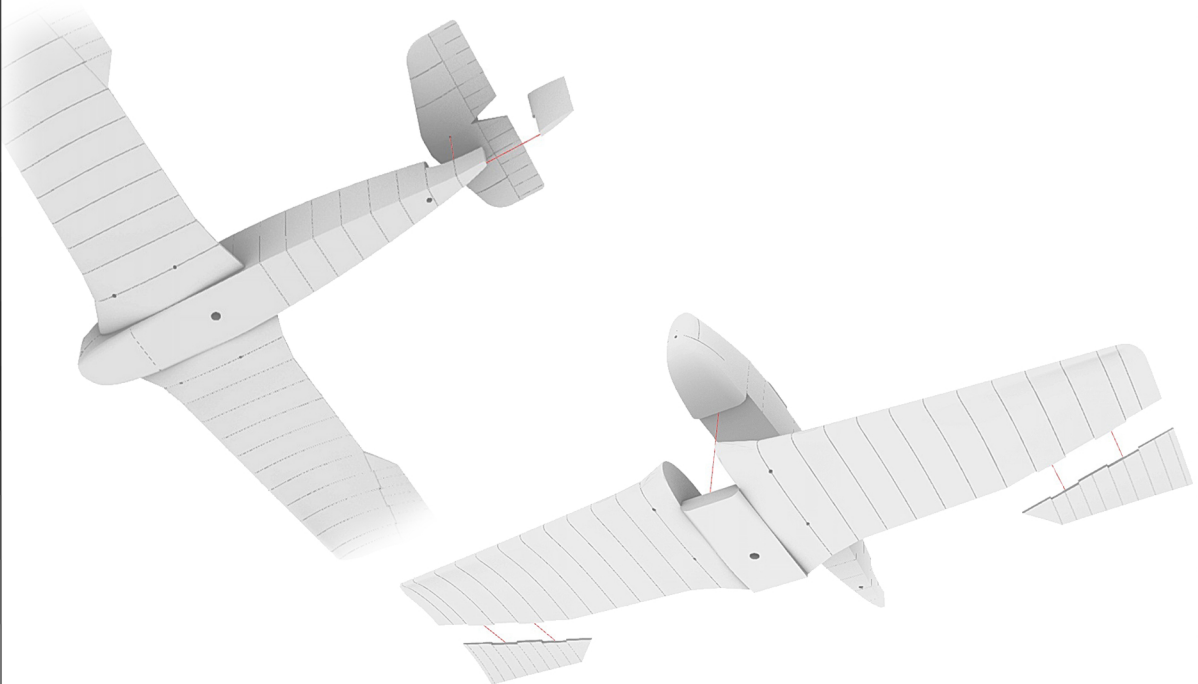
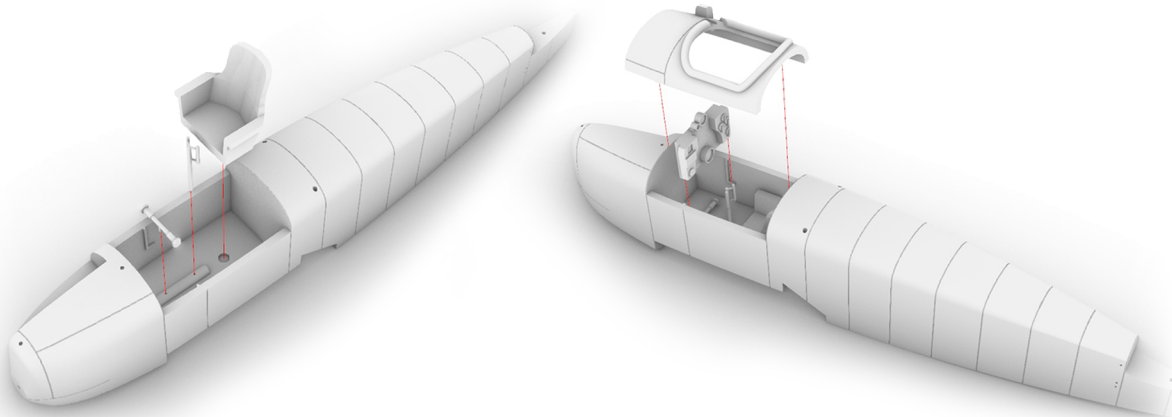

A: Control horns and, rigging not included