

Westland Sea King Collection Pt6



For the best results these decals should be applied to a gloss surface such as provided by either Xtracolor or Xtracrylix paints. Cut out the decal required and soak in warm water until the decal is released from the backing paper. Wet the area to be decaled with MICRO SET which will help to eliminate air trapped under the decal and position the decal.

After 5 or 10 minutes wet the decal with MICRO SOL which will soften the decal and ensure that it settles down over any surface detail. Allow the decal to dry for at least 12 hours. During this time some wrinkling of the decal may occur, this is normal. Do not touch the decal at this time.

Carefully check for small air bubbles and if there are any prick with a needle and apply a drop of MICRO SOL. After all air bubbles have been eliminated and the decals are dry wash the entire model with water to remove any excess decal adhesive.

When completely dry the whole model should be sprayed with a coat of Xtracolor or Xtracrylix Flat, Satin or Gloss varnish depending on the finish required.

Store in a cool dry place, avoid sunlight, dampness or extremes of temperature and/or humidity.

Westland Sea King Mk.43B,
 '073',
 of 330 Squadron,
 Royal Norwegian Air Force,
 Based at Bodø Main
 Air Station,
 Norway,
 2014.



'073' was finished in
 overall Gloss White with Day Glo Orange areas.
 Matt BS381C:642 Black exhaust and cockpit glazing areas.

Modellers Note:
 Six bladed tail rotor fitted.
 Nose radome will need to be
 sourced aftermarket.



Westland Sea King Mk.50A
 'N16-118'/'07'
 of 817 Squadron,
 Royal Australian Navy,
 2005.

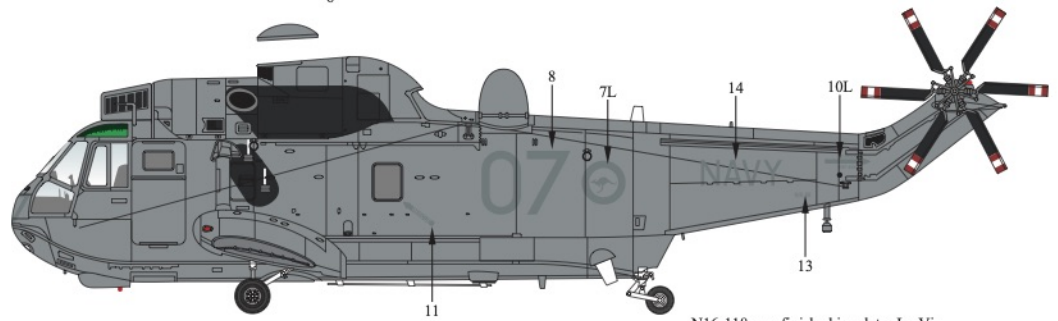

N16-118 was finished in a later Lo Viz
 scheme of overall Satin FS26320 Dark Compass Grey.
 Matt BS381C:642 Black radome, exhaust and cockpit glazing areas.

Modellers Note:
 Six bladed tail rotor fitted.

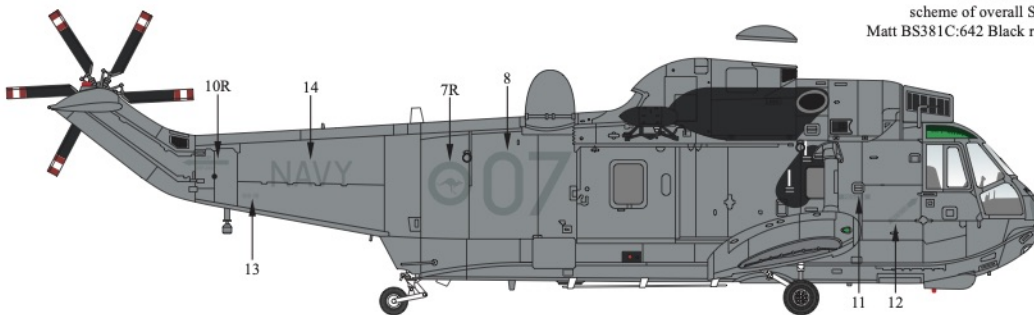

Westland Sea King Mk.45
 '11'
 Pakistan Navy,
 2005.

'11' was finished in
 overall Gloss BS381C:633 RAF Blue Grey
 with Matt BS381C:642 Black exhaust areas.
 Gloss White radome cap.

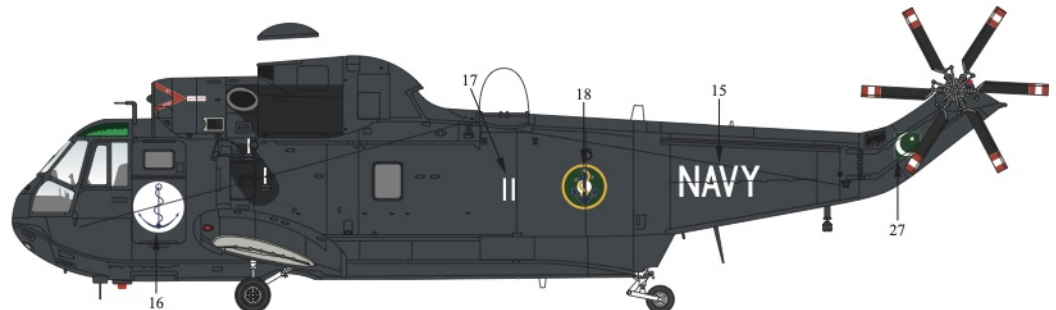

Modellers Note:
 Six bladed tail rotor fitted.

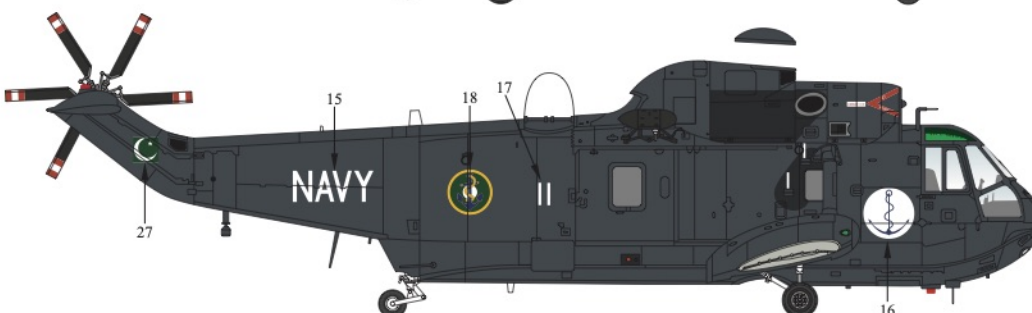

Westland Sea King Mk.41,
'89+51',
of Marinefliegergeschwader 5,
West German Navy,
Based at Kiel-Holtenau,
West Germany,
1992.

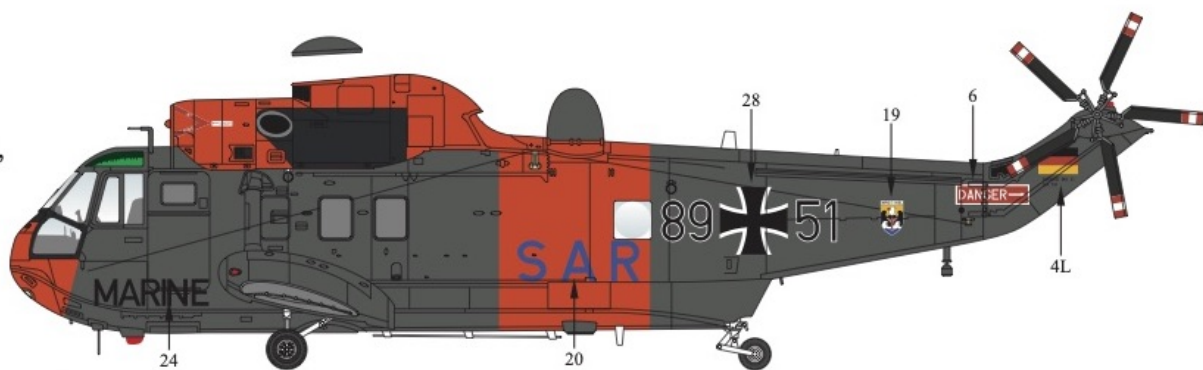

'89+51' was finished in overall Gloss RAL 7012 Basaltgrau with Day Glo Orange areas. Matt BS381C:642 Black exhaust and cockpit glazing areas.

Modellers Note:
Early five bladed tail rotor fitted.



Westland Sea King Mk.43B,
'073'.

Westland Sea King Mk.50A
'N16-118'/'07'.

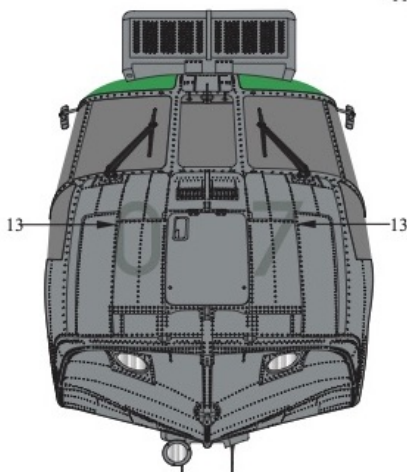
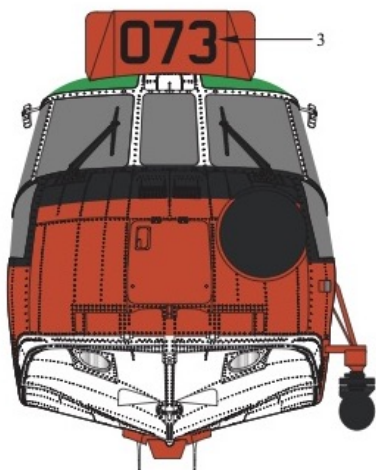

Uppersurfaces of Main
Rotor Blades

Lowersurfaces of Main
Rotor Blades

BS381C:356
Golden Yellow

BS381C:356
Golden Yellow

Westland Sea King Mk.45
'11'.

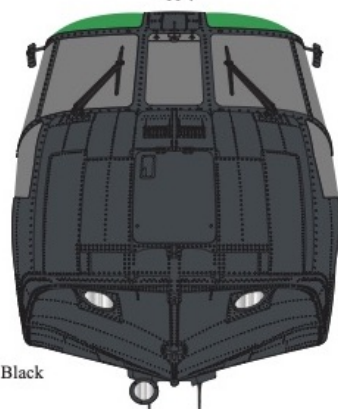

Westland Sea King Mk.43B,
'073' Undersides.

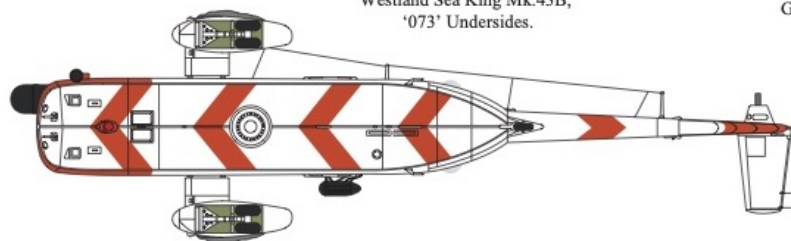

Westland Sea King Mk.50A
'N16-118'/'07' Undersides

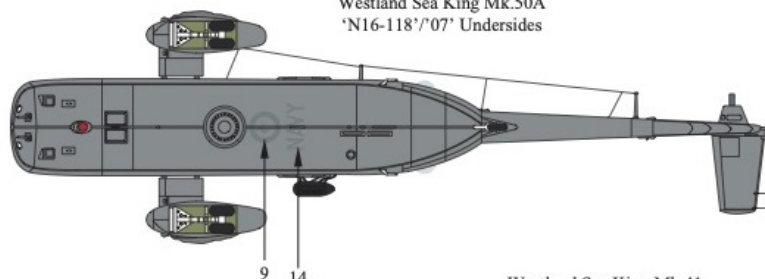

Tail Rotor Blades

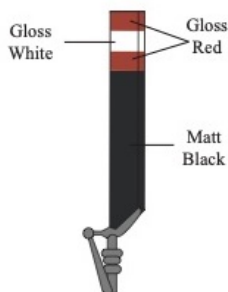

Westland Sea King Mk.41,
'89+51' Undersides.

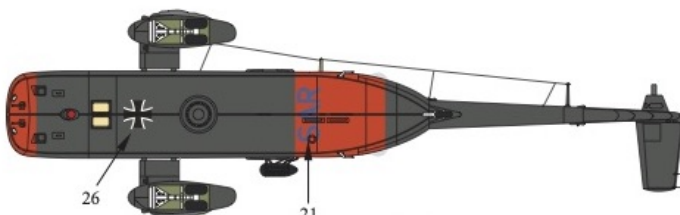

Many Thanks to:

Ian McGonagle for his help with this decal set.

Xtracolor Paints
X012 Night Black
X013 RAF Blue Grey
X135 Dark Compass Grey
X141 White
X254 Basaltgrau

Paints:

The colours used on these aircraft can be found in the Xtracolor (prefix number with X) and Xtracrylix (prefix number with XA1) range of paints.

Xtracolor Paints
XA1012 Night Black
XA1013 RAF Blue Grey
XA1135 Dark Compass Grey
XA1141 White
XA1254 Basaltgrau