

# Spitfire F Mk.IX

eduard

BRITISH WWII FIGHTER

1/72 SCALE PLASTIC KIT

ProfiPACK  
edition

#70122



## INTRO

In September 1941, a hitherto unknown German radial engine fighter appeared in the west European sky. The new airplane was superior to British fighters, most distressingly to the Spitfire Mk.V. The German design was soon recognized as the Focke-Wulf Fw 190A. The losses suffered by the RAF over western Europe rose rapidly and the crisis was serious enough that the RAF ceased the majority of daytime operations in November 1941. The next attempt to resume these types of sorties was made in March 1942. Loss rates remained unacceptably high and the RAF was forced to stop ops once again. All this was thanks to the Focke-Wulf Fw 190A. The first response to the new German weapon was the Spitfire Mk.VIII, but the design changes were so complex that initiating timely production was not possible. In June 1942 a German pilot landed by mistake on a British airfield delivering a completely intact Fw 190 fighter into RAF hands. Comparative trials between the Focke-Wulf and Spitfire Mk.V began almost immediately. These mock encounters confirmed the situation over the front – the chances of a British fighter surviving an encounter with the Fw 190 were slim. The only British fighter aircraft deemed suitable to oppose them were the Spitfire Mk. VII and VIII powered by the Merlin 61 engine. As mentioned above these were some time away of being ready for series production. But there was another way of getting a powerful fighter quickly - by mating the Merlin 61, with its two-stage supercharger, with the fuselage of the Spitfire Mk.Vc. Two Mk.Vc airframes, AB196 and AB197, were selected for this purpose and were strengthened with modified longerons to accommodate the more powerful and heavier engine. The example was finished on February 26 and the second on March 27, 1942. Flight trials were successful and the order for series production was issued almost immediately. Series production began in June 1942 and the first Mk.IXs found their way to No. 64 Squadron in July. Performance improved significantly in comparison to the Mk. V. A top speed of 409 mph at 28,000 feet was higher by 40mph, and the service ceiling rose from 36,200 to 43,000 feet. The Mk.IX could climb at 4,000 feet per minute. The RAF finally had a fighter aircraft capable of opposing the Fw 190 A. Three main versions of the Mk. IX were produced. The F.IX was powered by the Merlin 61 and was the only version on the assembly line in early 1943. The next version was the LF Mk.IX powered by the Merlin 66. This engine was designed to do its best at low altitudes. The third version, manufactured along with the LF, was the high-altitude HF Mk.IX with the Merlin 70. The majority of Mk.IXs manufactured were equipped with the so-called 'C' wing. Four 20 mm cannons or two 20 mm cannons and four .303 machine guns could be installed in the wings. From 1944 the strengthened 'E' wing was produced. Four .303 machine guns were replaced with two .50 heavy machine guns. Bomb racks for 250 lb bombs were fitted under each wing typically. The Mk.IX became the second most numerous version of the Spitfire with a total of 5653 examples being built. The Mk.IX began to replace the Mk.V from June 1942. Thanks to the new fighter, the RAF was ready to fight against the Luftwaffe over occupied Europe. Spitfire Mk.IXs served with the RAF to the end of war. In the postwar era, foreign air forces flew this version as well. Czechoslovak, Norwegian, Danish, and Canadian air forces operated numbers of Mk.IXs and they were not alone. Spitfires would find themselves in combat again. Czechoslovakia sold its Spitfire Mk.IXs to Israel in 1948 and these aircraft formed the backbone of the newly born Israeli air force in the fight against their Arab neighbours.

ATTENTION



UPOZORNĚNÍ



ACHTUNG



ATTENTION



注意



Carefully read instruction sheet before assembling. When you use glue or paint, do not use near open flame and use in well ventilated room. Keep out of reach of small children. Children must not be allowed to suck any part, or pull vinyl bag over the head.



Před započatím stavby si pečlivě prostudujte stavební návod. Při používání barev a lepidel pracujte v dobře větrané místnosti. Lepidla ani barvy nepoužívejte v blízkosti otevřeného ohně. Model není určen malým dětem, mohlo by dojít k požití drobných dílů.

INSTRUCTION SIGNS \* INSTR. SYMBOLS \* INSTRUKTION SINNBILDEN \* SYMBOLES \* 記号の説明

OPTIONAL  
VOLBABEND  
OHNOUTOPEN HOLE  
VYVRTAT OTVORSYMETRICAL ASSEMBLY  
SYMETRICKÁ MONTÁŽNOTCH  
ZÁŘEZREMOVE  
ODŘÍZNOUTAPPLY EDUARD MASK  
AND PAINT  
POUŽÍ EDUARDS MASK  
NABARVIT

PARTS



DÍLY



TEILE



PIĚCES



部品

## PLASTIC PARTS

**A>** 70120 A

**B>** 70120 B

**C>** 70120 C

**D>** 70120 D

**E>** 70120 E

**G>** 70120 G

**eduard MASK**

**PE - PHOTO ETCHED  
DETAIL PARTS**

-Parts not for use. -Teile werden nicht verwendet. -Pièces à ne pas utiliser. -Tyto díly nepoužívejte při stavbě. - 使用しない部品

COLOURS



BARVY



FARBEN



PEINTURE



色

GSI Creos (GUNZE)		
AQUEOUS	Mr. COLOR	
H4	C4	YELLOW
H12	C33	FLAT BLACK
H3	C3	RED
H33	C81	RUSSET
H51	C11	LIGHT GULL GRAY
H71	C21	MIDDLE STONE
H72	C369	DARK EARTH
H77	C137	TIRE BLACK

AQUEOUS	Mr. COLOR	
	C361	DARK GREEN
	C362	OCEAN GRAY
	C363	MEDIUM SEA GRAY
	C364	AIRCRAFT GRAY GREEN
	C368	SKY
	C370	AZURE BLUE
Mr. METAL COLOR		
	MC214	DARK IRON
	MC218	ALUMINIUM



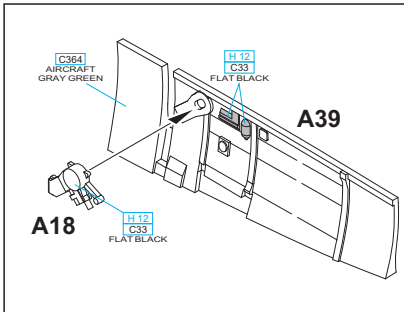

**? FOR CLOSED CANOPY ONLY**

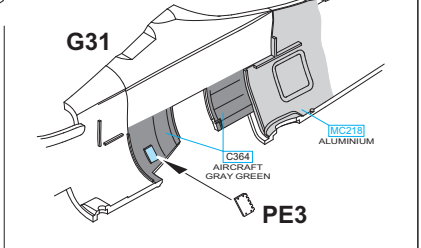
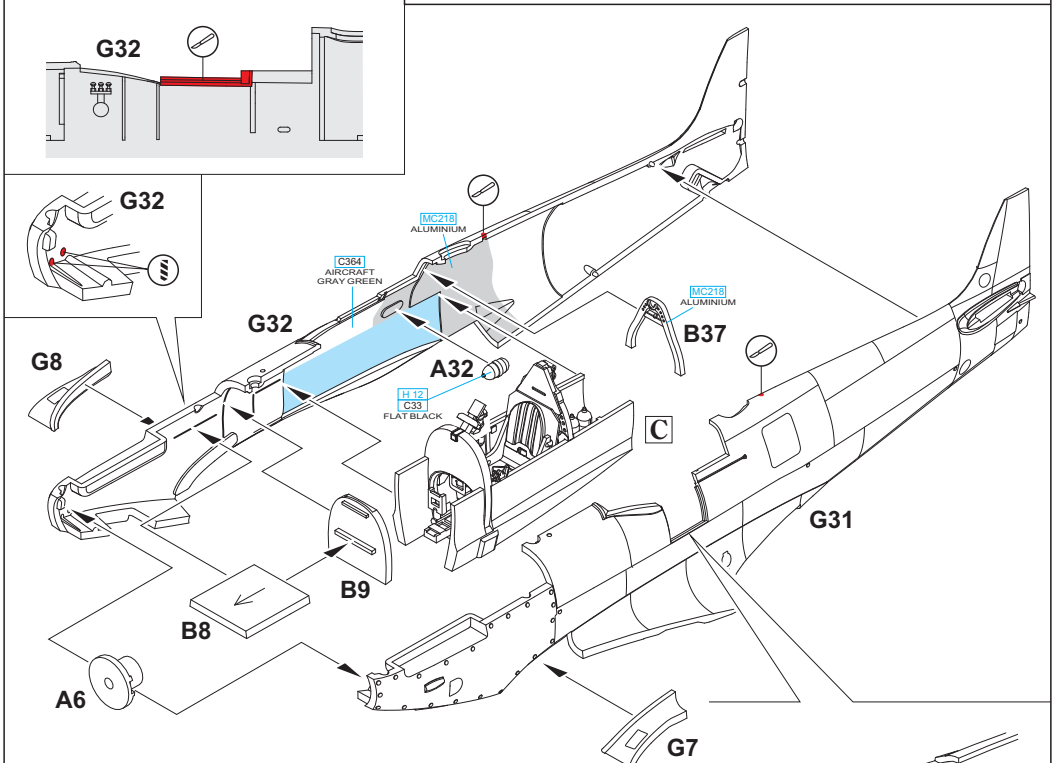
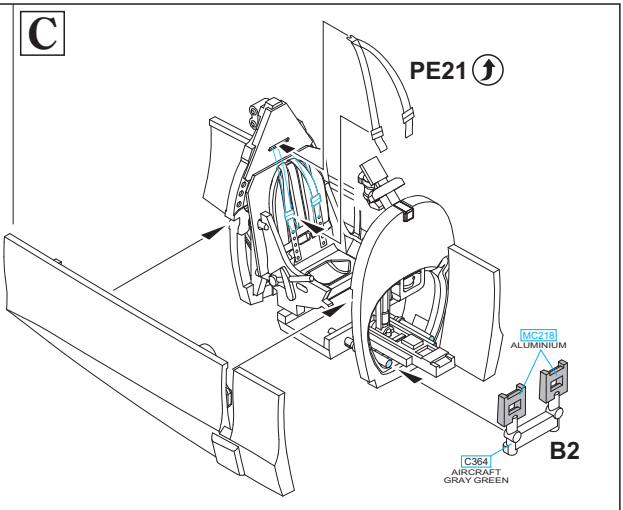
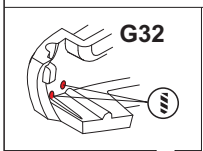
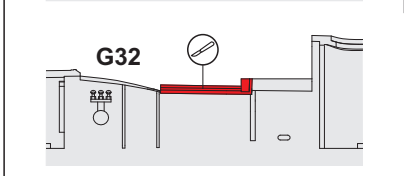
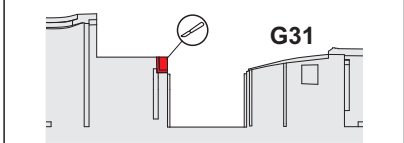

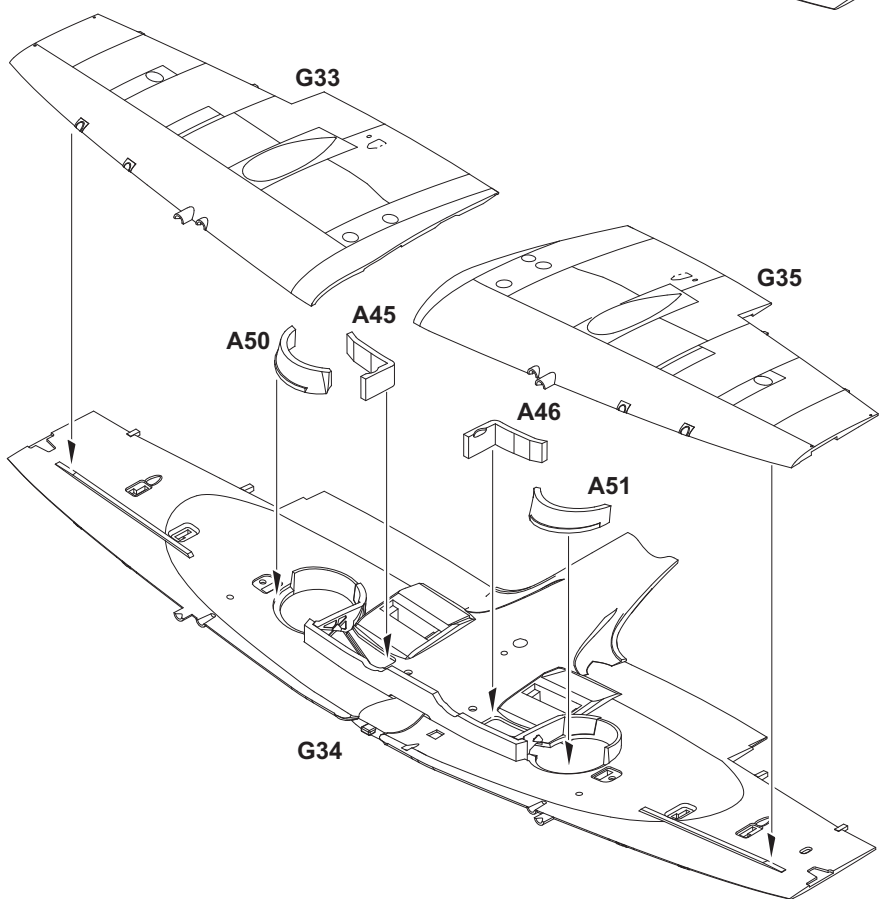
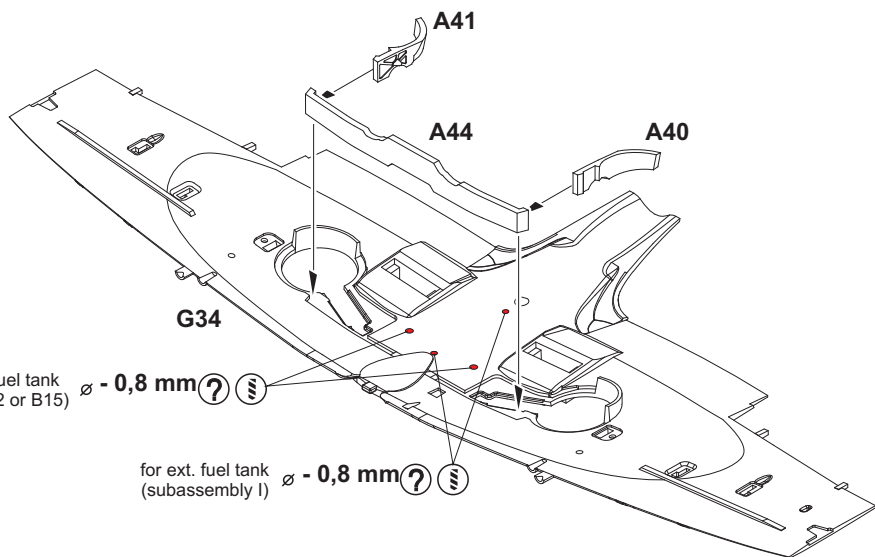

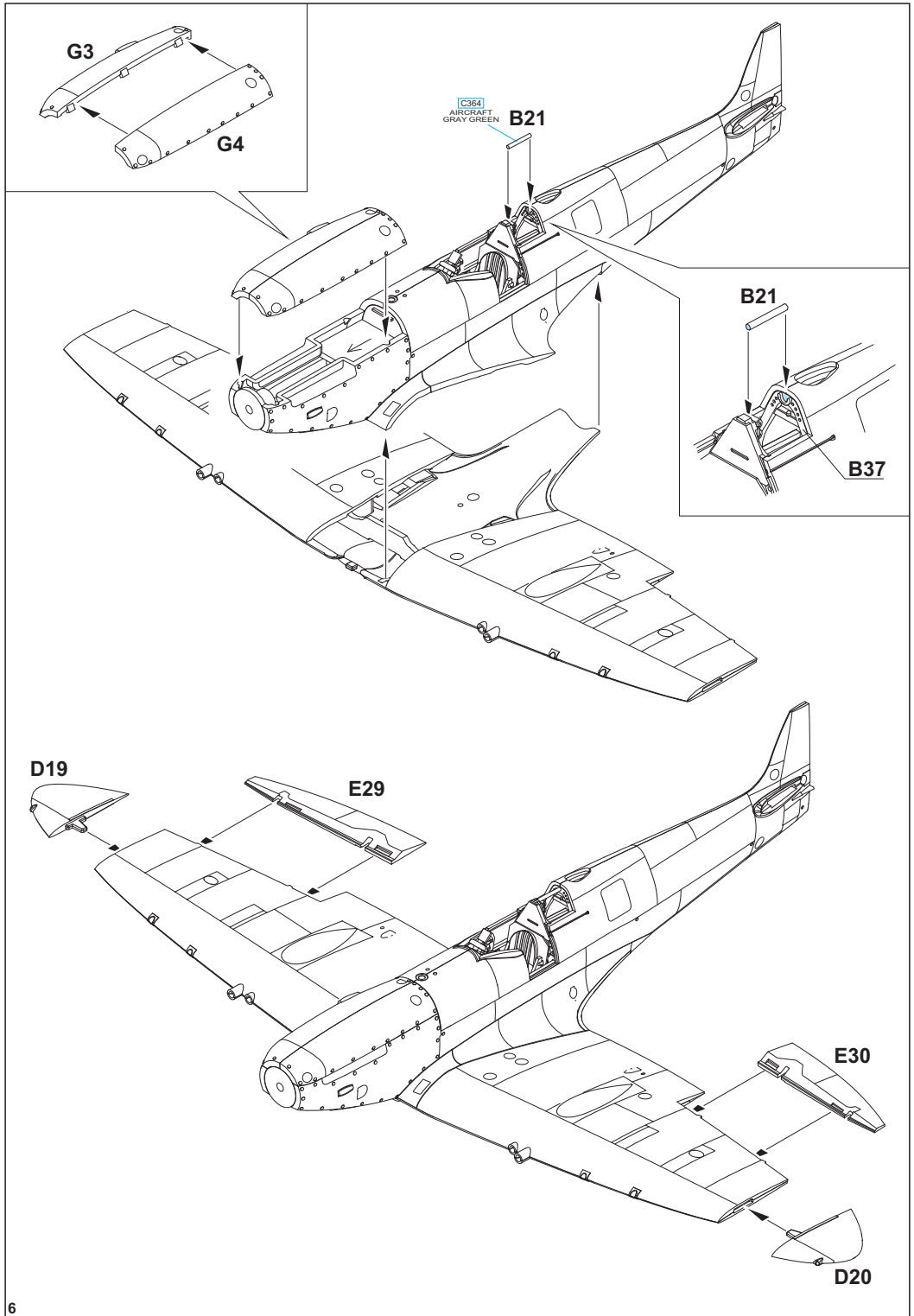

D17

G14

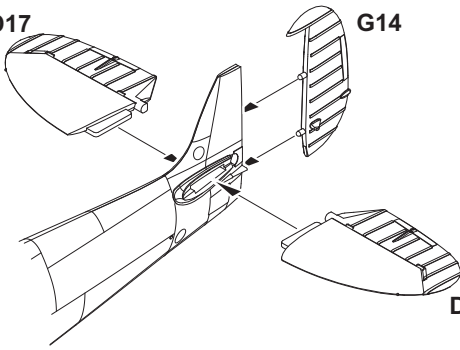

D18

H77  
C137  
TIRE BLACK

A13

MC218  
ALUMINIUM

UNDERSURFACE  
COLOR

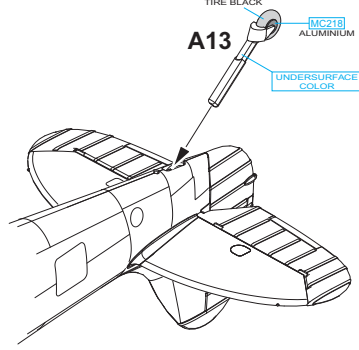

D

PE18

UNDERSURFACE  
COLOR

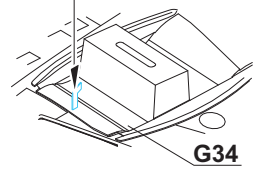

G34

B23

B22

B51

UNDERSURFACE  
COLOR

B35

UNDERSURFACE  
COLOR

B50

B48

UNDERSURFACE  
COLOR

B35

UNDERSURFACE  
COLOR

B46

MC218  
ALUMINIUM

PE14

MC218  
ALUMINIUM

PE15

MC218  
ALUMINIUM

PE17

G6

PE16

MC218  
ALUMINIUM

D

A22

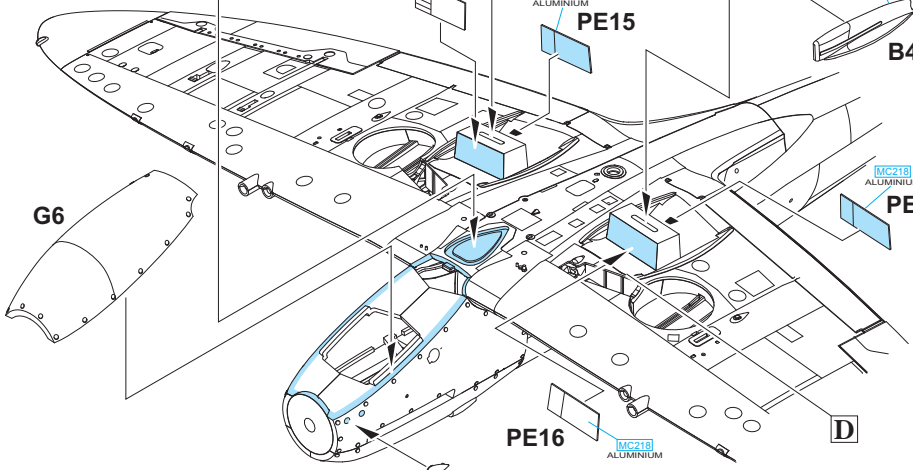

PE13 - MARKING C ONLY

PE13 - MARKING C ONLY

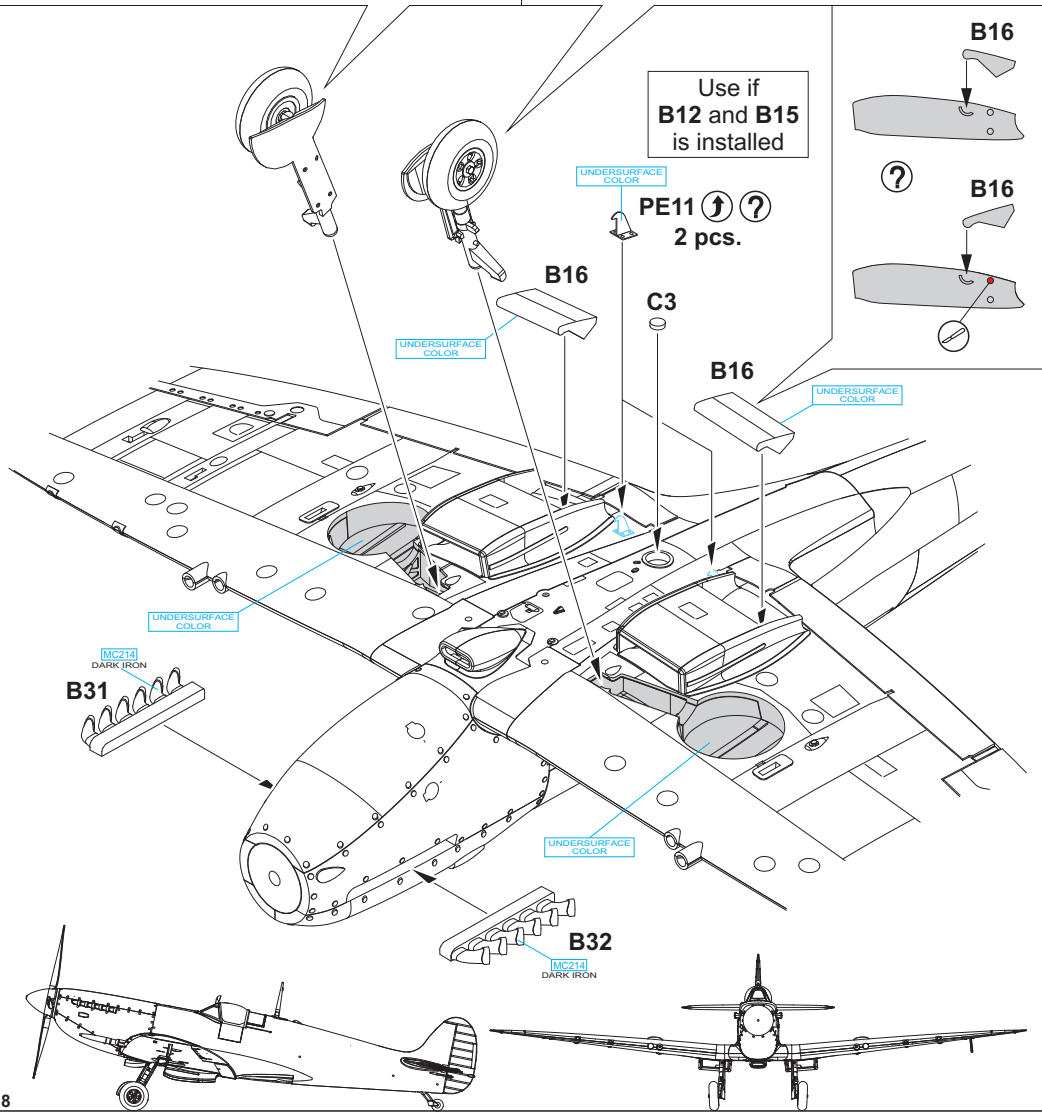
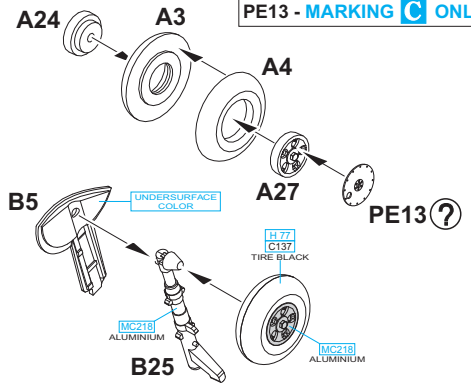
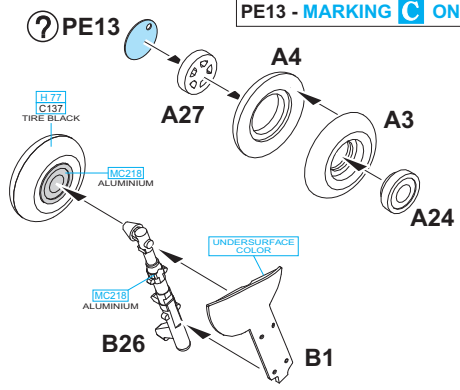

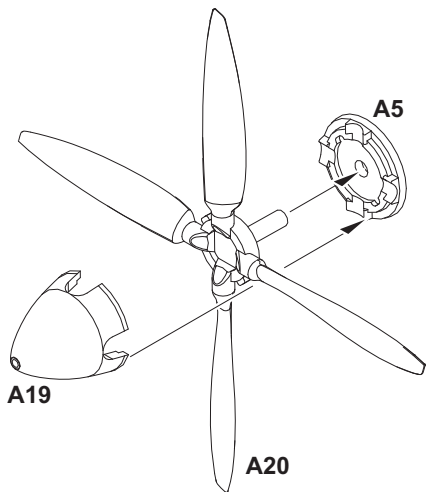
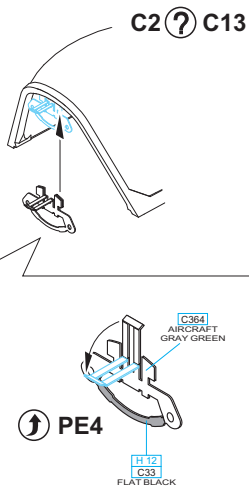
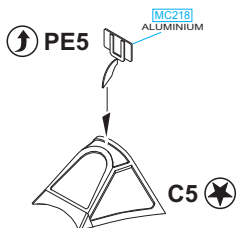
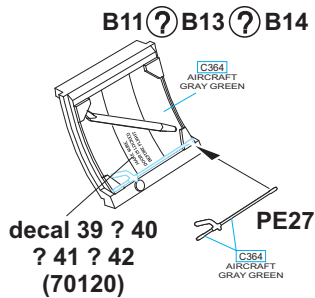
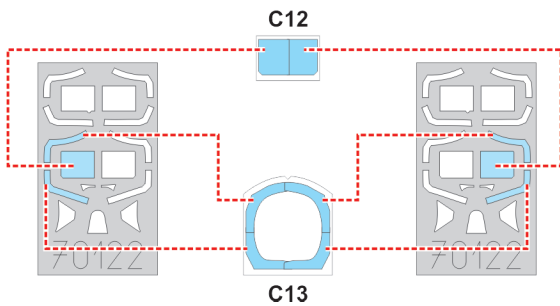
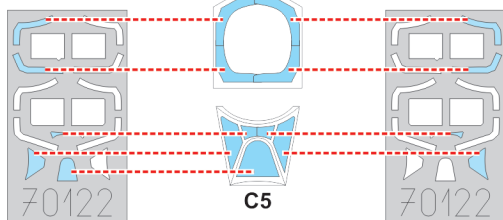
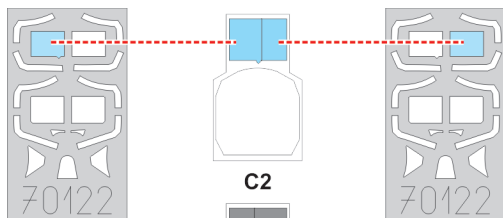
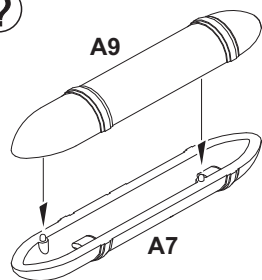

**E****F****G****H****I****?**

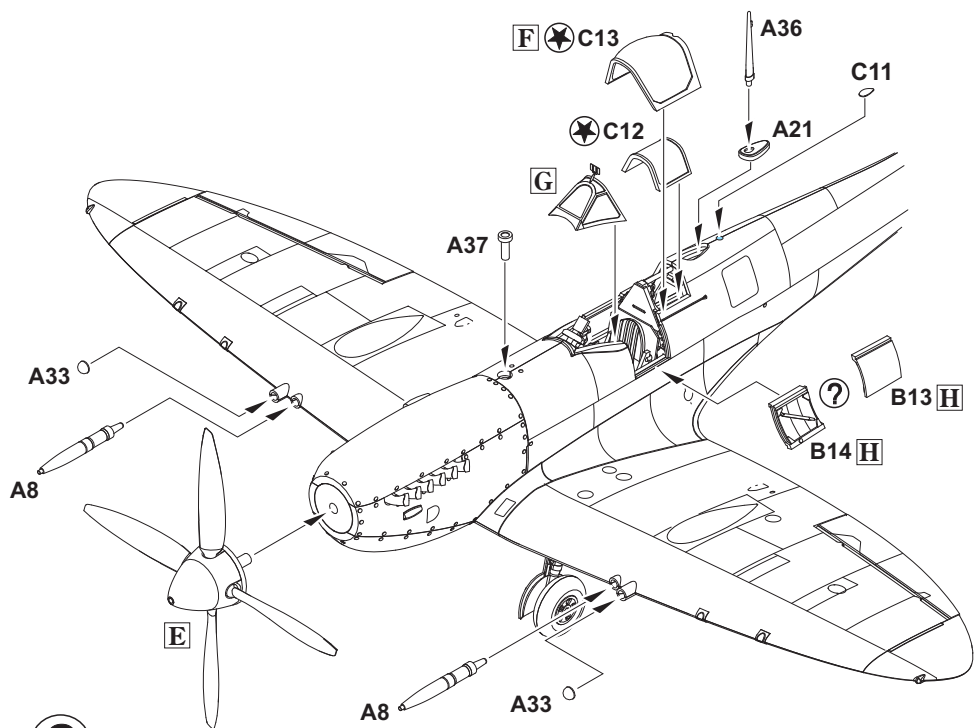

?

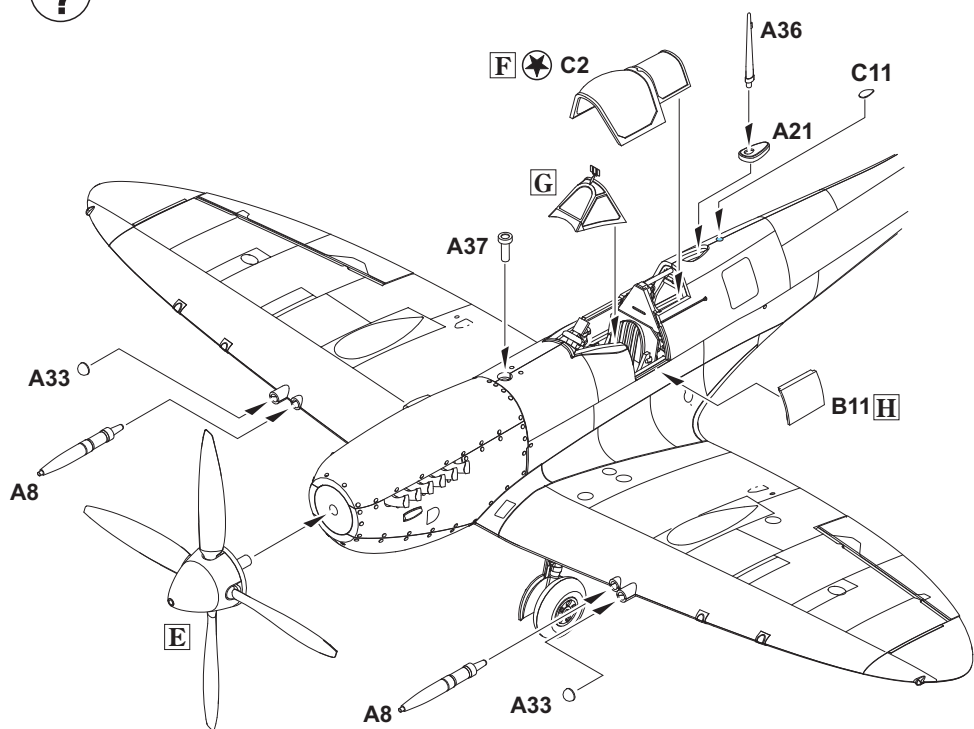

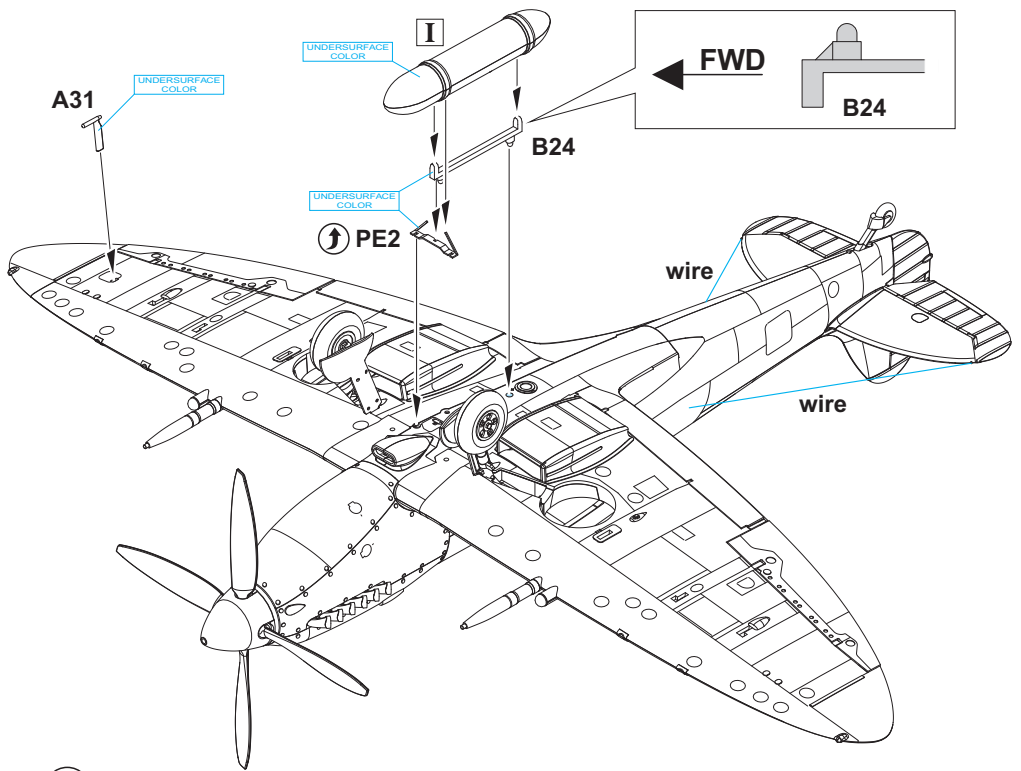

?

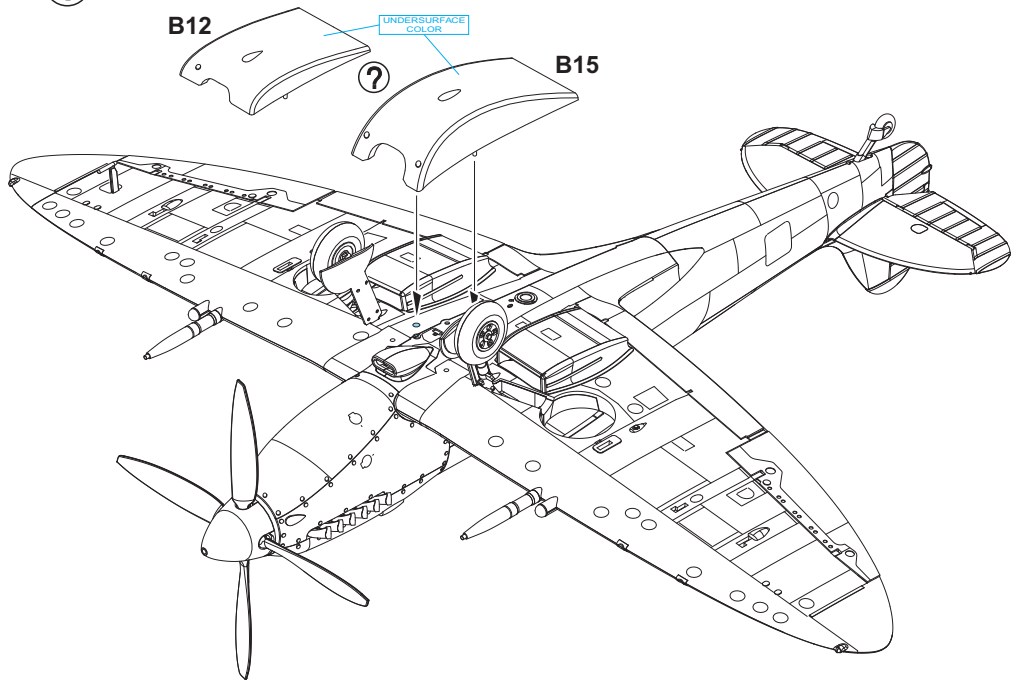

**A** BS392, S/Ldr. Bernard Dupérier, CO of No. 340 Squadron, Biggin Hill Airbase, Autumn 1942

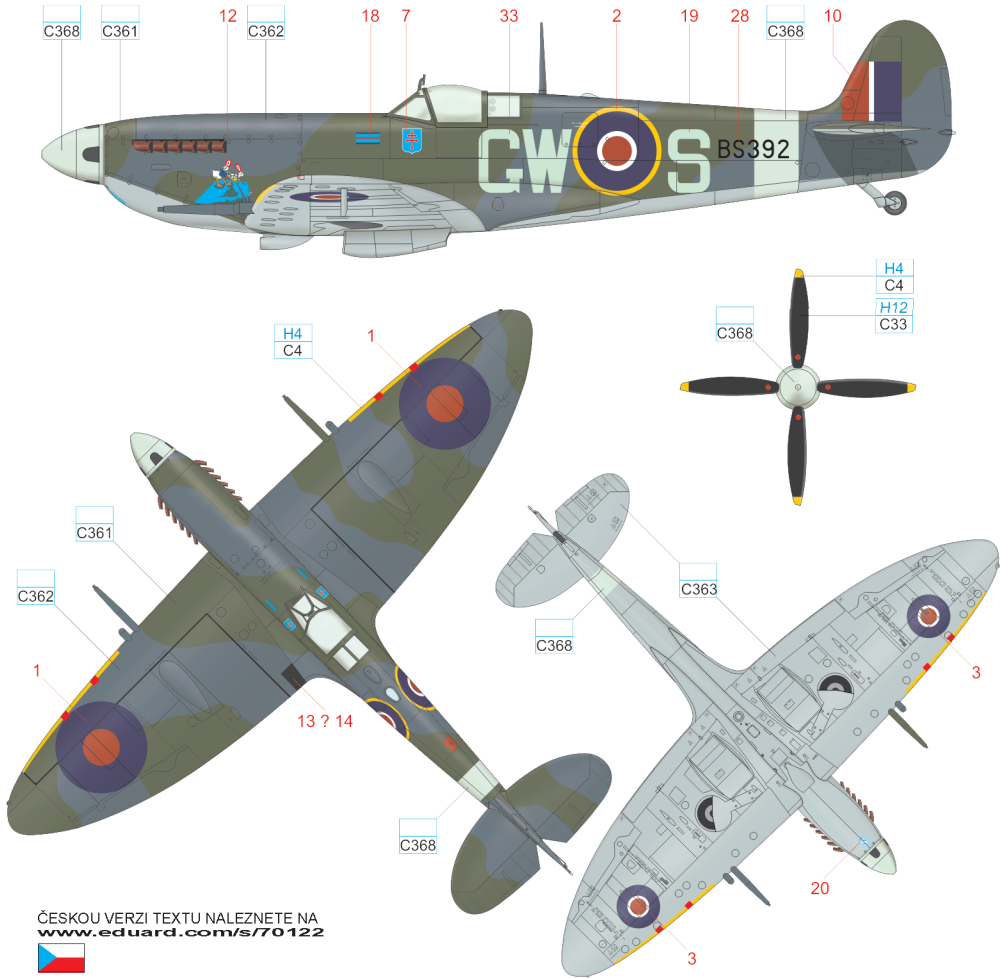

ČESKOU VERZI TEXTU NALEZNETE NA  
[www.eduard.com/s/70122](http://www.eduard.com/s/70122)



YELLOW	H4 C4	RED	H3 C3
SKY	C368	MEDIUM SEA GRAY	C363
OCEAN GRAY	C362	DARK GREEN	C361
BLACK	H12 C33		

# B EN315, S/Ldr. Stanislav Skalski, Polish Combat Team, Northern Africa, Spring 1943

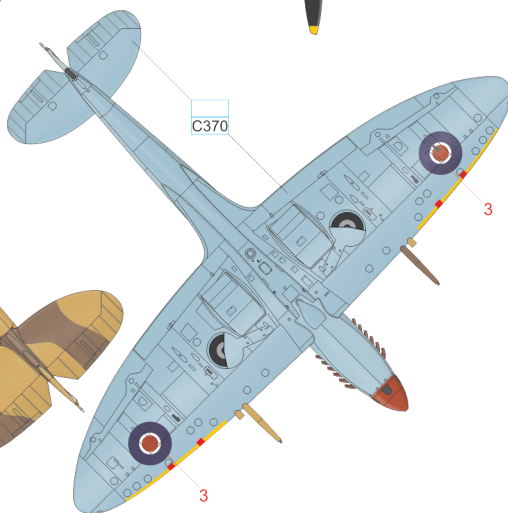
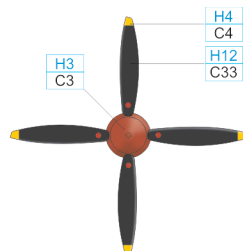
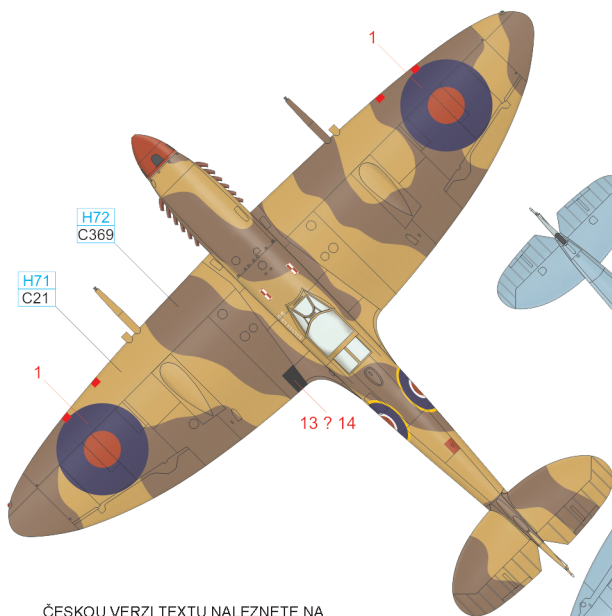
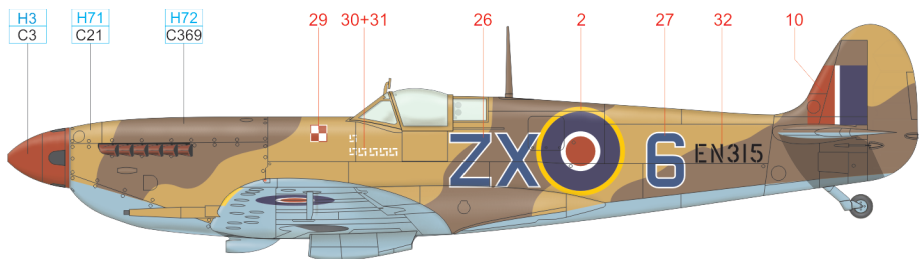

ČESKOU VERZI TEXTU NALEZNETE NA  
[www.eduard.com/s/70122](http://www.eduard.com/s/70122)

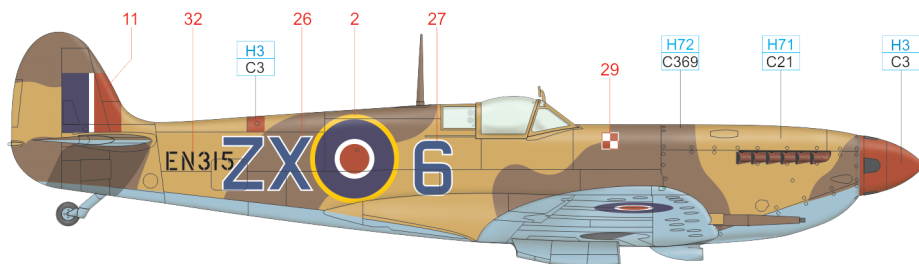

YELLOW	H4 C4	RED	H3 C3
AZURE BLUE	C370	MIDDLE STONE	H71 C21
		DARK EARTH	H72 C369
		BLACK	H12 C33

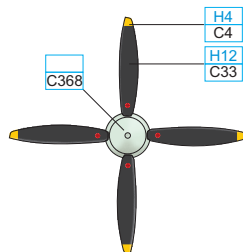
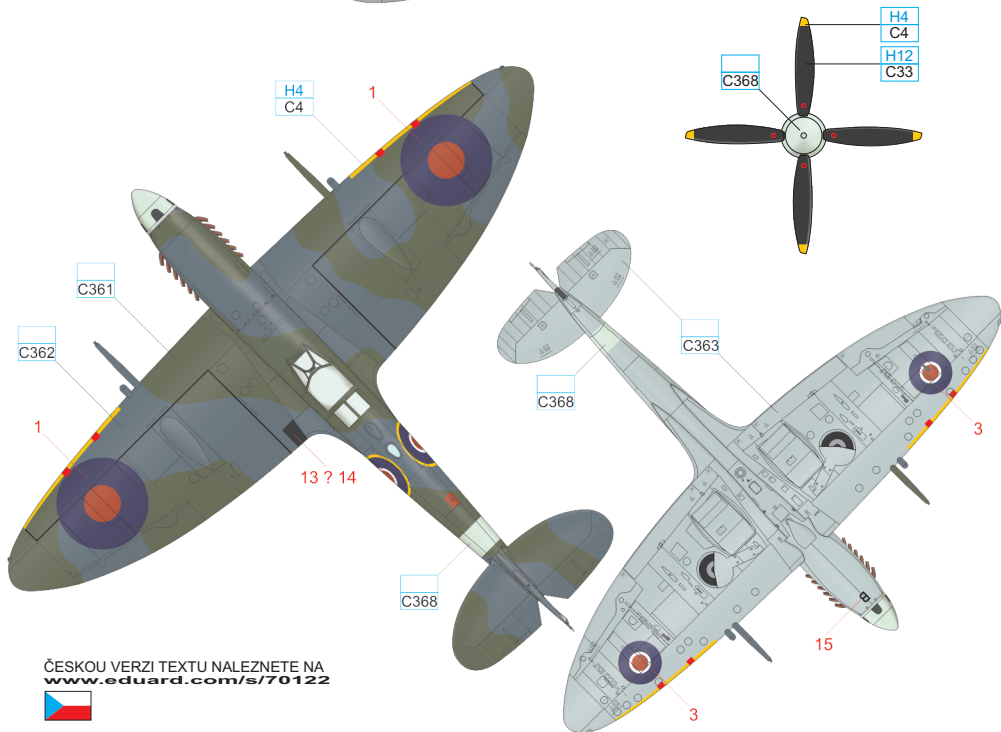
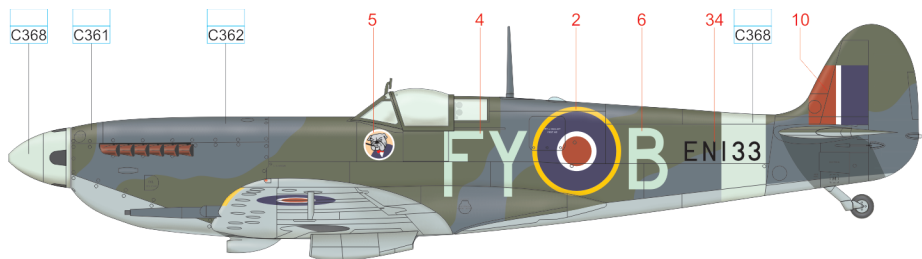

ČESKOU VERZI TEXTU NALEZNETE NA  
[www.eduard.com/s/70122](http://www.eduard.com/s/70122)

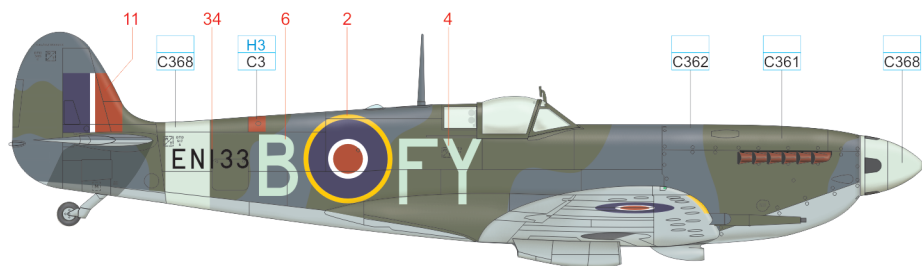

YELLOW	H4 C4	RED	H3 C3
--------	----------	-----	----------

SKY	C368	MEDIUM SEA GRAY	C363	OCEAN GRAY	C362	DARK GREEN	C361	BLACK	H12 C33
-----	------	--------------------	------	------------	------	------------	------	-------	------------

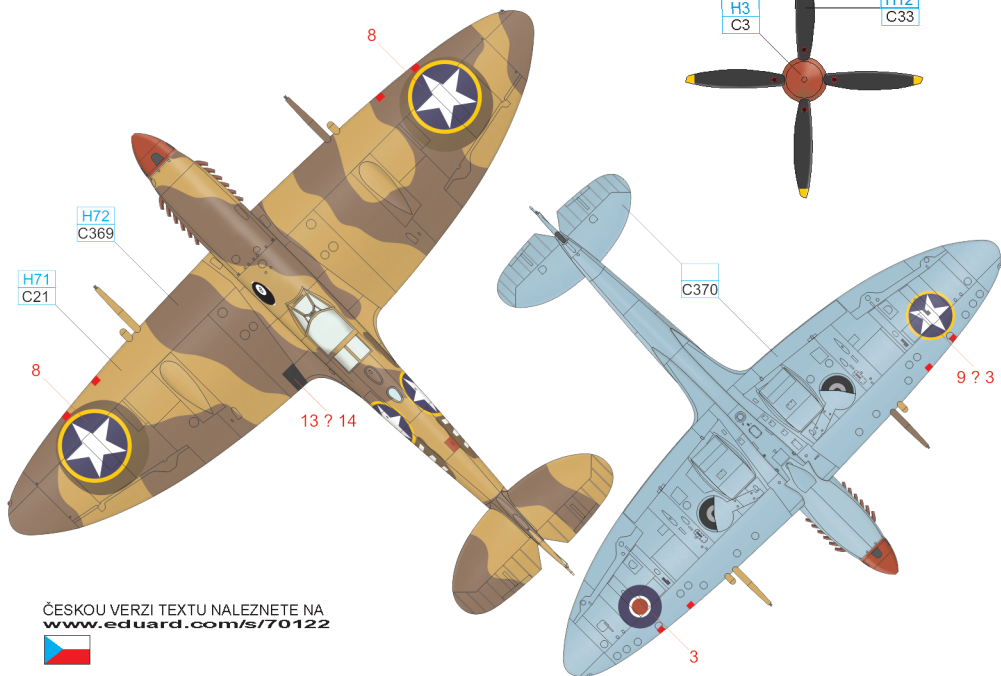
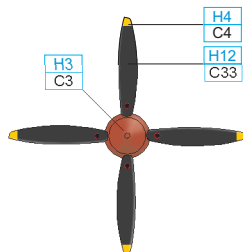
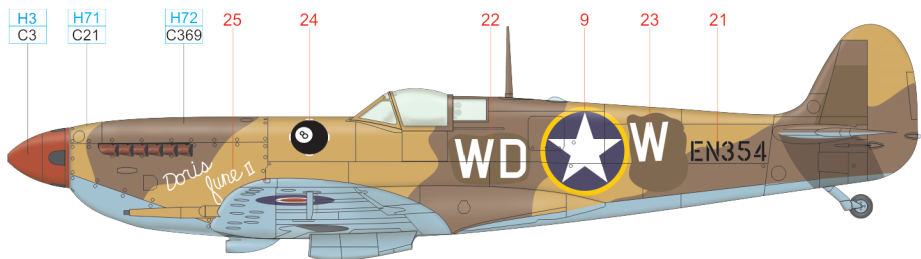

ČESKOU VERZI TEXTU NALEZNETE NA  
[www.eduard.com/s/70122](http://www.eduard.com/s/70122)

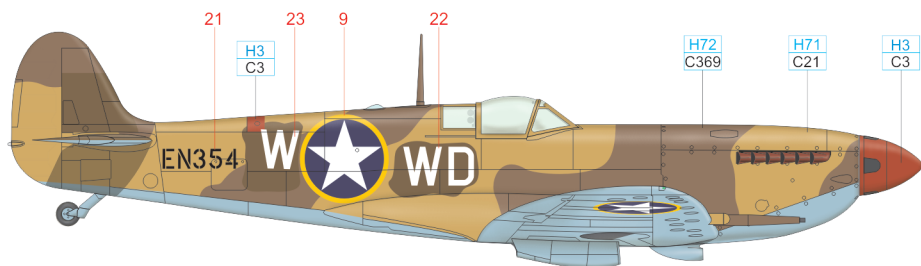

YELLOW	H4 C4	RED	H3 C3
--------	----------	-----	----------

AZURE BLUE	C370	MIDDLE STONE	H71 C21	DARK EARTH	H72 C369	BLACK	H12 C33
---------------	------	-----------------	------------	------------	-------------	-------	------------

