

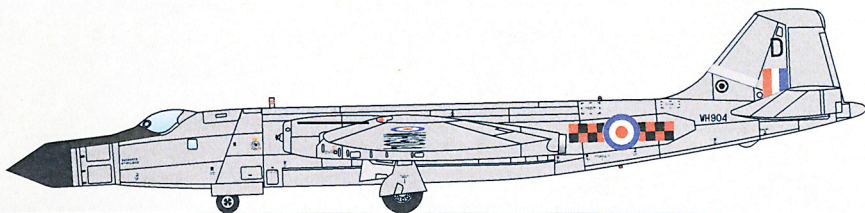

# 1/72 SCALE MODEL CONSTRUCTION KIT English Electric Canberra T.11/TP.52

72004



English Electric Canberra T.11 була створена в 1958 році як тренажер повітряно-десантних перехоплень для екіпажів Gloster Javelin. З цією метою були вилучені з резерву літаки модифікації B.2 і оснащені під гострим конічним носом станції радіолокації Ferranti AIRPASS AI/17. Окрім того, що літаки служили для тренування екіпажів радарів перехоплення, T.11 був і загальним навчальним літаком для всього екіпажу, і часто на борту було чотири члени екіпажу: учень і інструктор-навігатор, сиділи в задній частині кабіни, а пілота курсант і інструктор - у передній, причому останній - на розкладному стільці біля місця пілота. З середини 1960-х років ця роль Канберри стала не потрібна, і більшість з T.11 змінили свої радари на носовий баласт, перетворившись на прості навчальні машини для пілотування.

Всього у стандарт T.11 перероблено дев'ять B.2. Шведські військово-повітряні сили придбали дві Канберри у RAF в 1960 році, і вони були змінені до стандарту T.11 фірмою Boulton Paul. Літаки були потім модифіковані в Швеції як шпигунські літаки для перехоплення радянських, польських та східногерманських військових радіопередач, хоча це було не публічно. Канберри отримали позначення TP.52 і находились в експлуатації у якості "випробувального літака", поки не були замінені двома T3.85 Caravelle в 1971 році.

The English Electric Canberra T.11 was introduced in 1958 as a radar airborne intercept trainer for Gloster Javelin crews. Redundant B.2s were taken out of storage for this purpose, and fitted with a sharply-pointed conical nose housing the Ferranti AIRPASS AI/17 radar. In addition to serving as a radar intercept trainer, the T.11 served the role as general crew trainer and it was not uncommon for it to carry four crew; a pupil and instructor navigator seated in the rear, and a pilot and pupil pilot seated in front, the latter on the fold-down rumble seat adjacent to the pilot. By the mid 1960s, this role was no longer needed, and many T.11s had their radars removed and replaced with nose ballast, thus becoming the Canberra T.19 general crew trainer.

Nine B.2s converted to trainers for pilots and navigators of all-weather interceptors to operate the Airborne Intercept radar, crew of four.

The Swedish Air Force purchased two Canberras from the RAF in 1960 and had these modified to T11s by Boulton Paul. The aircraft were secretly modified in Sweden as espionage aircraft for eavesdropping on primarily Soviet, Polish and East German military radio transmissions, although this was not publicly admitted until 10 years later. The Canberras were given the designation Tp 52, and taken into service as "testing aircraft", until they were replaced by two Tp 85 Caravelles in 1971

## Технічні характеристики / Technical specifications:

Довжина/Length - 20,56 м; Розмах/Wingspan - 19,50 м; Висота/Height - 4,77 м; Злітна маса/Loaded weight - 24915 kg  
 Дальність польоту/Range - 5440 км; Крейсерська швидкість/Cruising speed - 830 км/г;  
 Макс. висота польоту/Ceiling - 14630 м; Екіпаж/Equipage - 3.

## СПЕЦІАЛЬНІ СИМВОЛИ/USED SYMBOLS



CEMENT  
КРЕМТ



DON'T CEMENT  
НЕ КРЕМТ



REMOVE  
ВІДРІЗАТИ



SYMMETRICAL  
СИМЕТРИЧНО



MULTIPLE  
КРАТНО



BEND  
ЗІГНУТИ



OPEN WHOLE  
СВЕРДЛИТИ



VARIANTS  
ВАРІАНТИ



TO PAINT  
ФАРБУВАТИ

## КОЛЬОРИ ФАРБ/USED PAINTS



White  
Humbrol 34



Black  
Humbrol 85



Matt Black  
Humbrol 33



Steel  
Humbrol 27003



Aluminum  
Humbrol 86



Light Grey  
Humbrol 64



Red  
Humbrol 153



Yellow  
Humbrol 24



Brown  
Humbrol 186



Pale Yellow  
Humbrol 81



**PARTS OF THE MODEL**

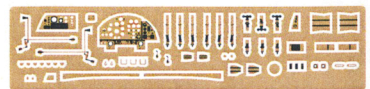
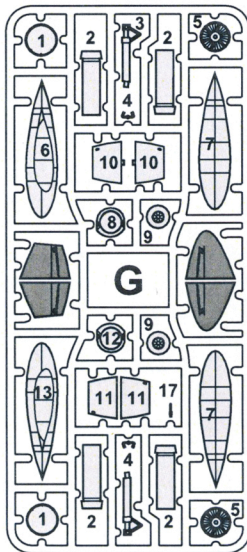
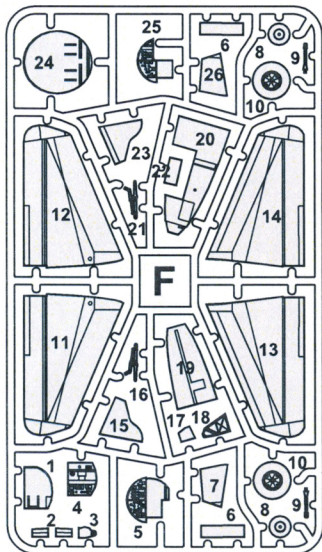
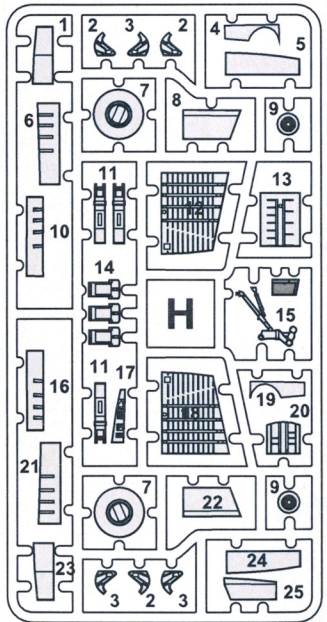
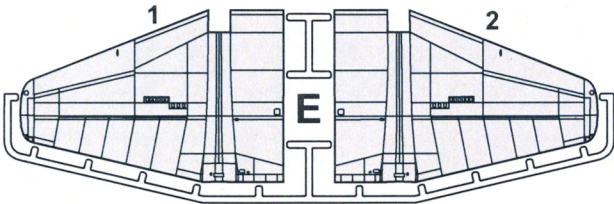
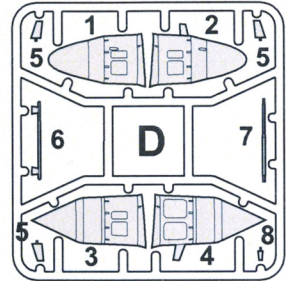
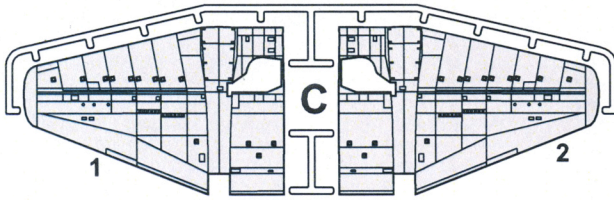
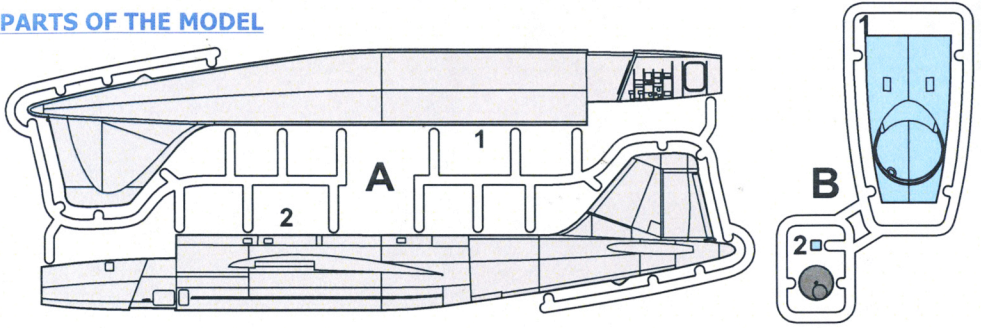

**PARTS OF THE MODEL**

**Addition to page 2**

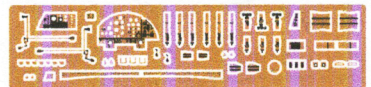
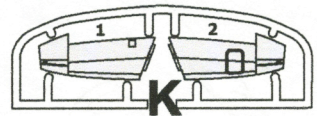
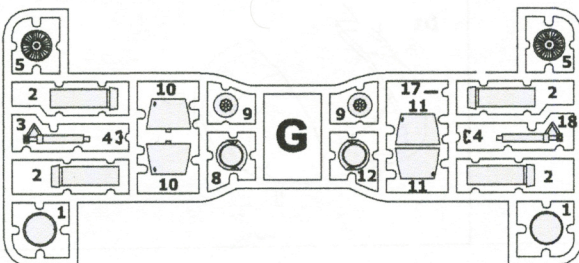
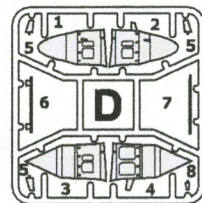
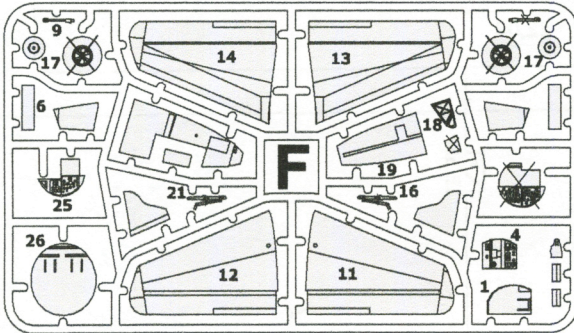
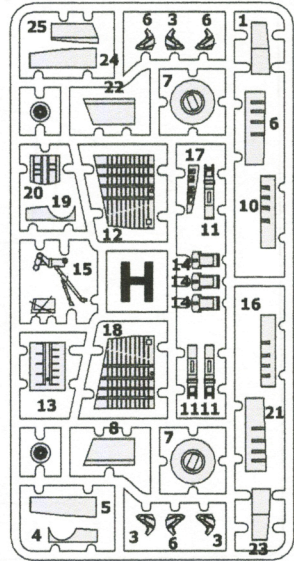
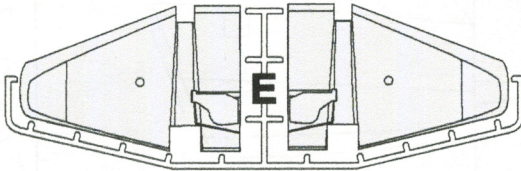
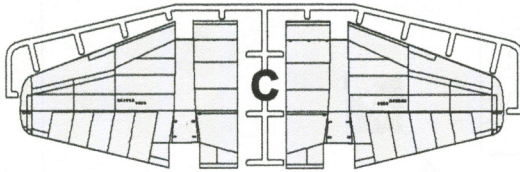
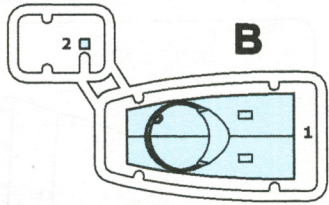
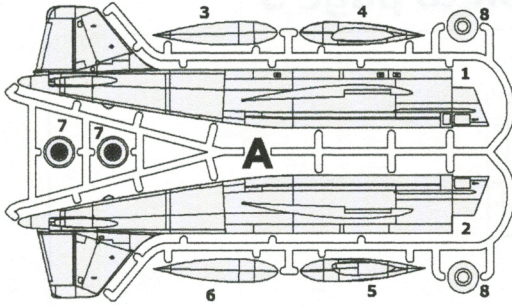



1 F25; Pe6; film

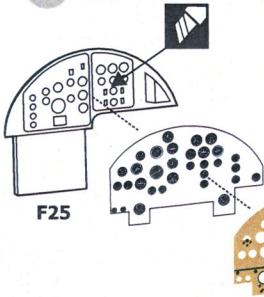

2 F4,F6; Pe3; film

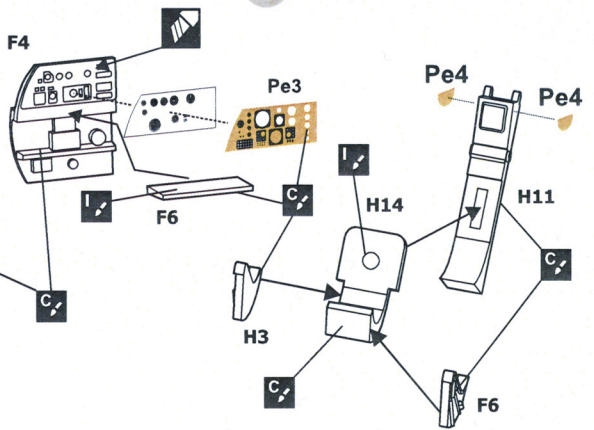

4 F26;H8,H13,H20,H22

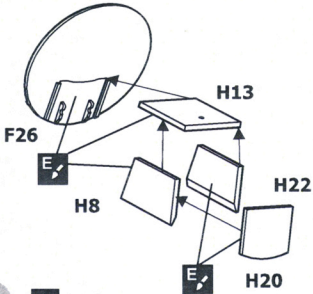

5 F19

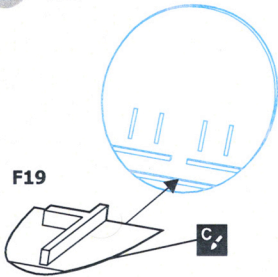

6 F20;Pe7x2,Pe8x2,Pe9x2,Pe13x2,Pe23x2

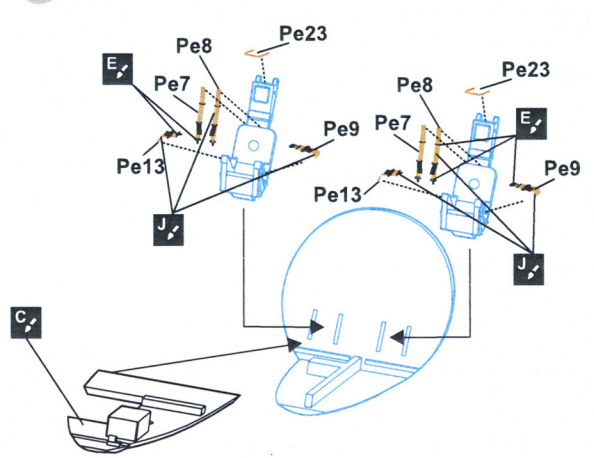

7 F9; G4; Pe22

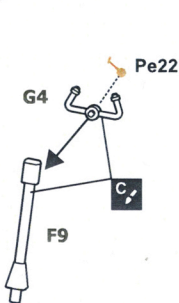

8 F18; Pe14,Pe15

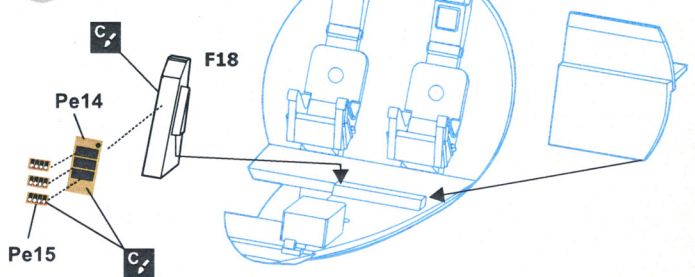



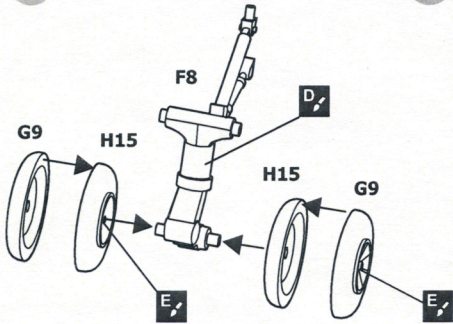

**9**  F8x2; G9x2,H15

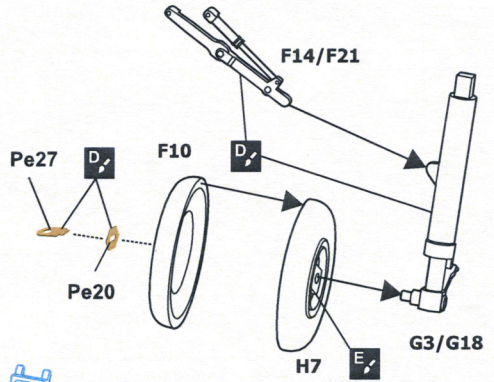

**10**   F10x2,F16,F21; G3,G18; H7; Pe20,Pe27



**11**  H17, H25; Pe10

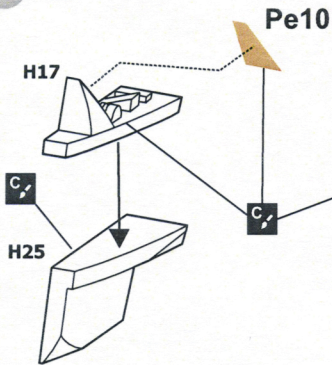

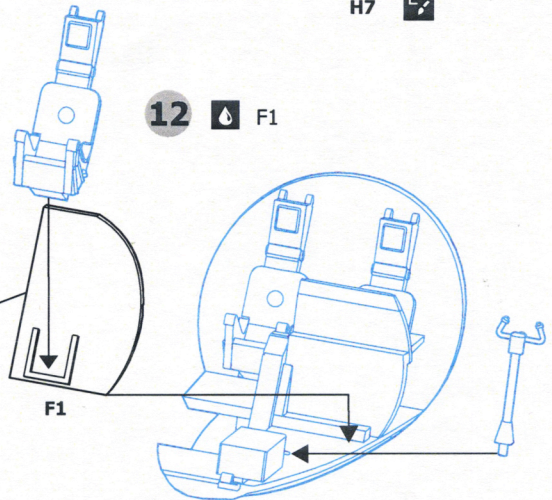

**12**  F1

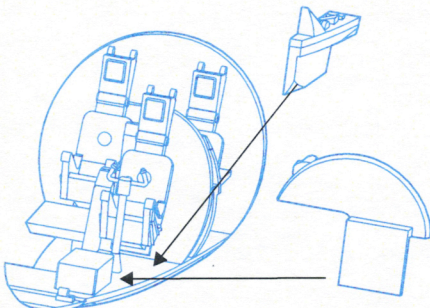

**13** 



**14**   H1,H4,H5,H6,H10,H12,H16, H18,H19,H21,H23,H24

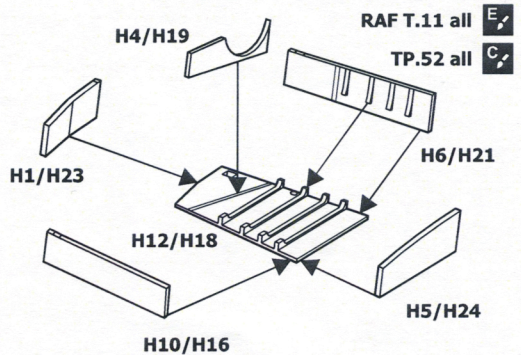

15  A1,A2; B1,B2; D1,D2,D3,D4

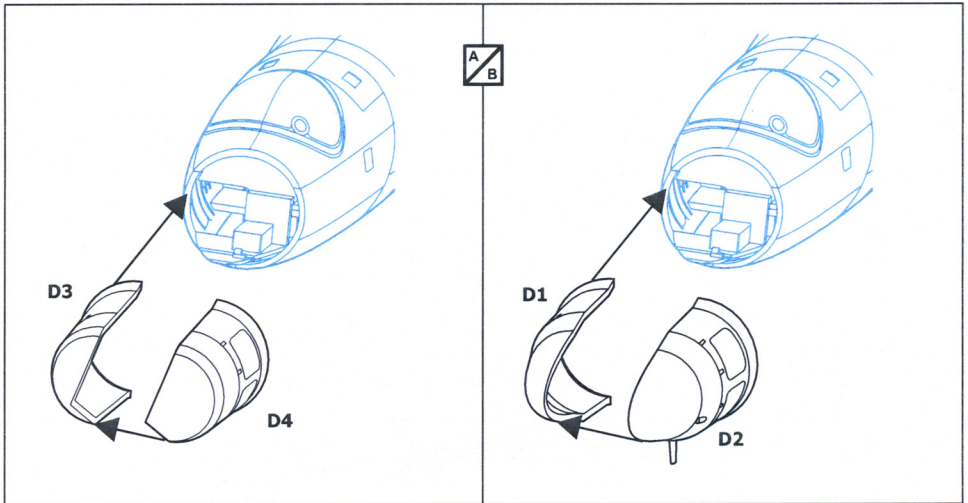
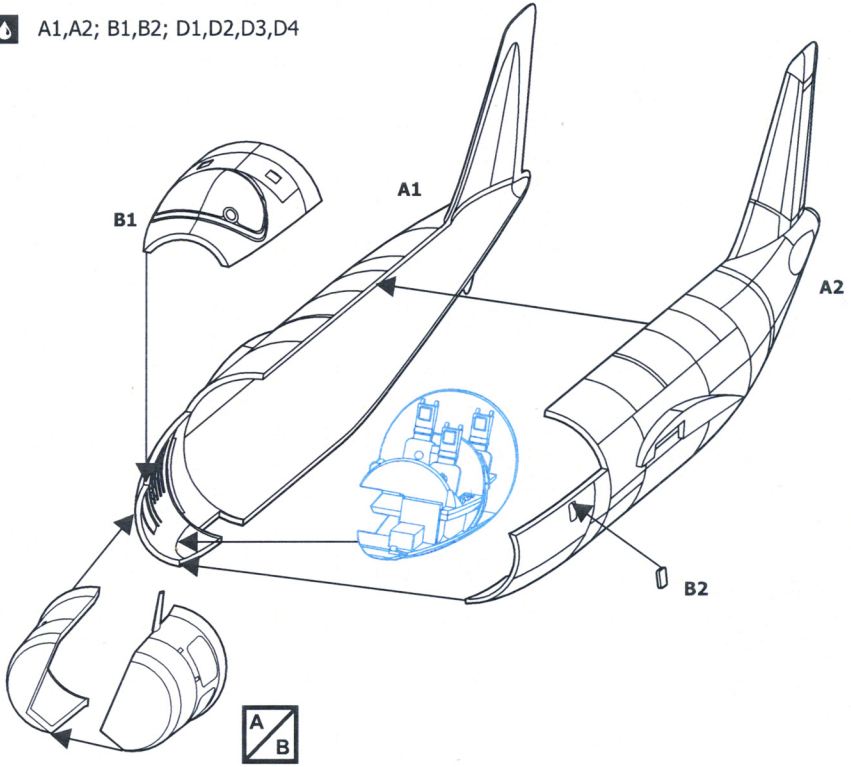



# Addition to page 5

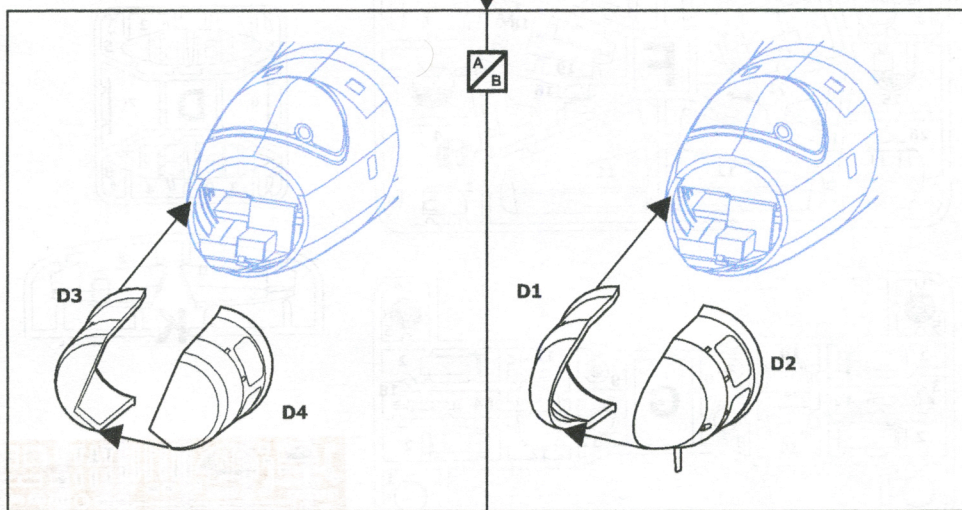
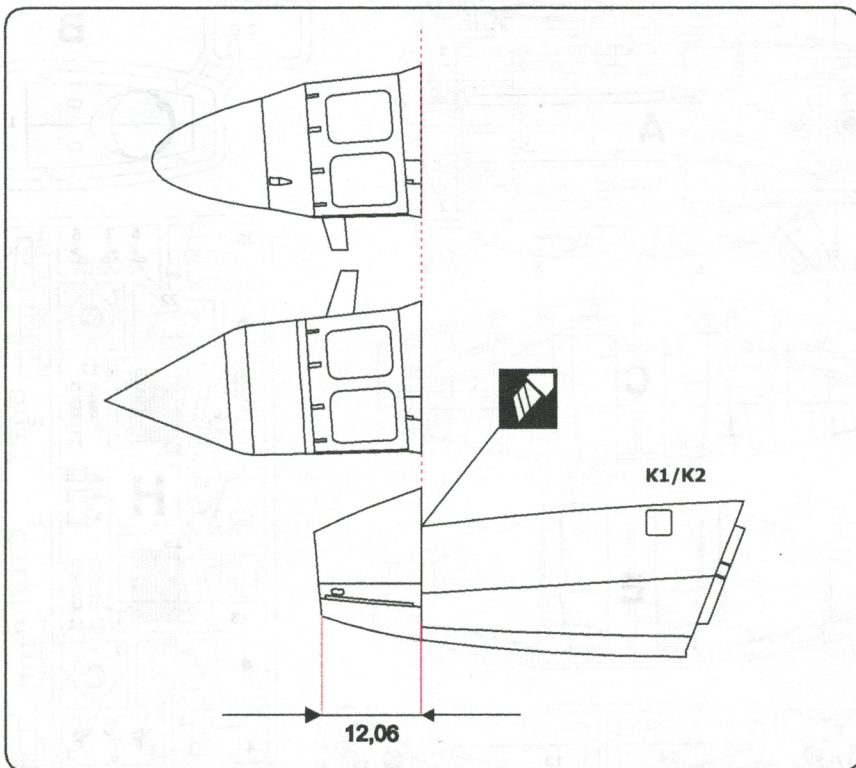

**16** x2 AA  G2x4,G8,G12

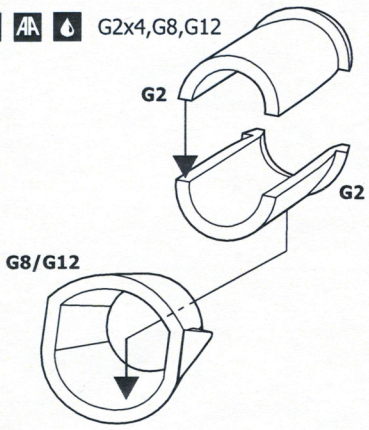

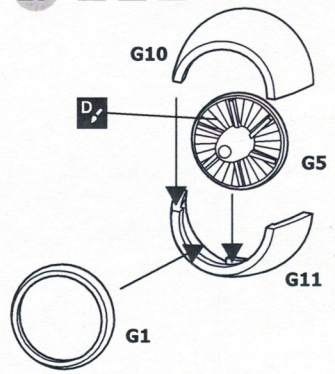

**17** x2 AA  G1,G5,G10,G11

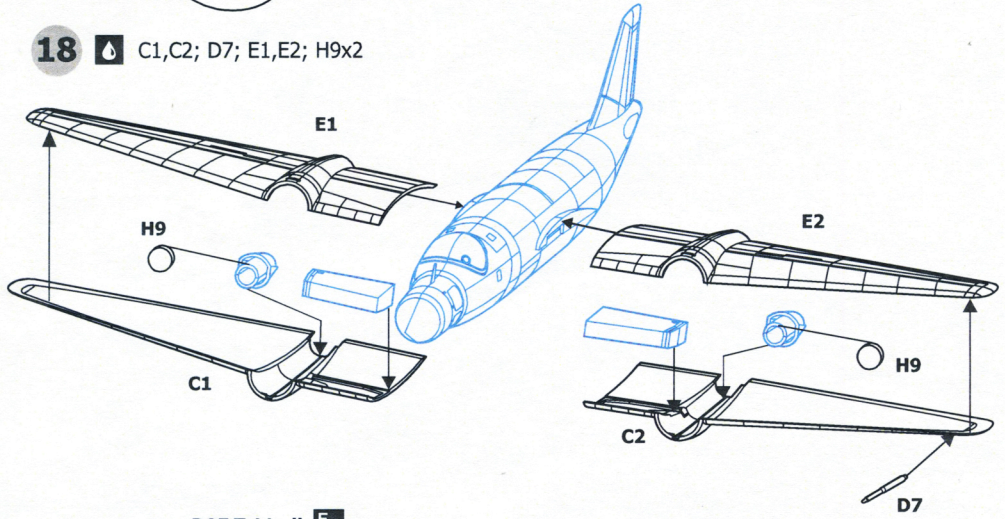

**18**  C1,C2; D7; E1,E2; H9x2



**19**  F6x2 RAF T.11 all  TP.52 all 

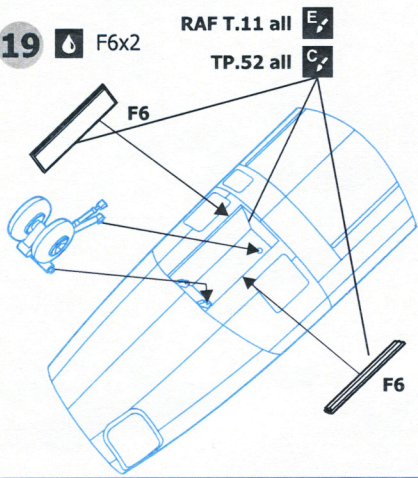

**20**  Pe24,Pe26/27, Pe28

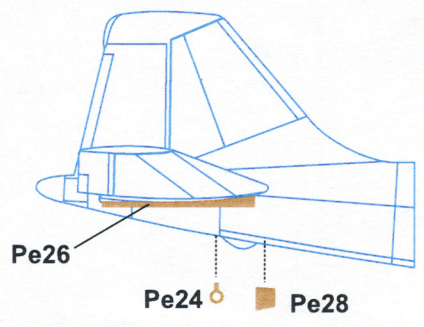



**21**  F11,F12,F13,F14; G6,G7x2,G13

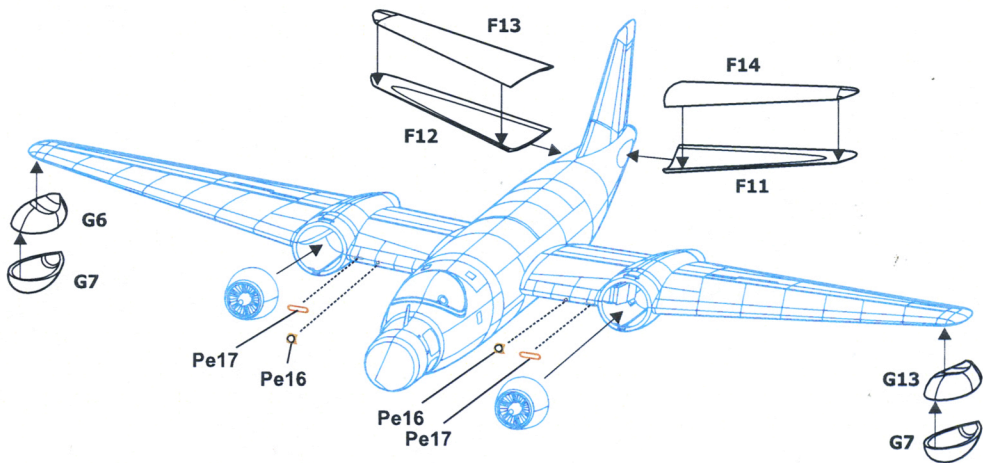

**22**  F2x2,F7,F15,F23,F26

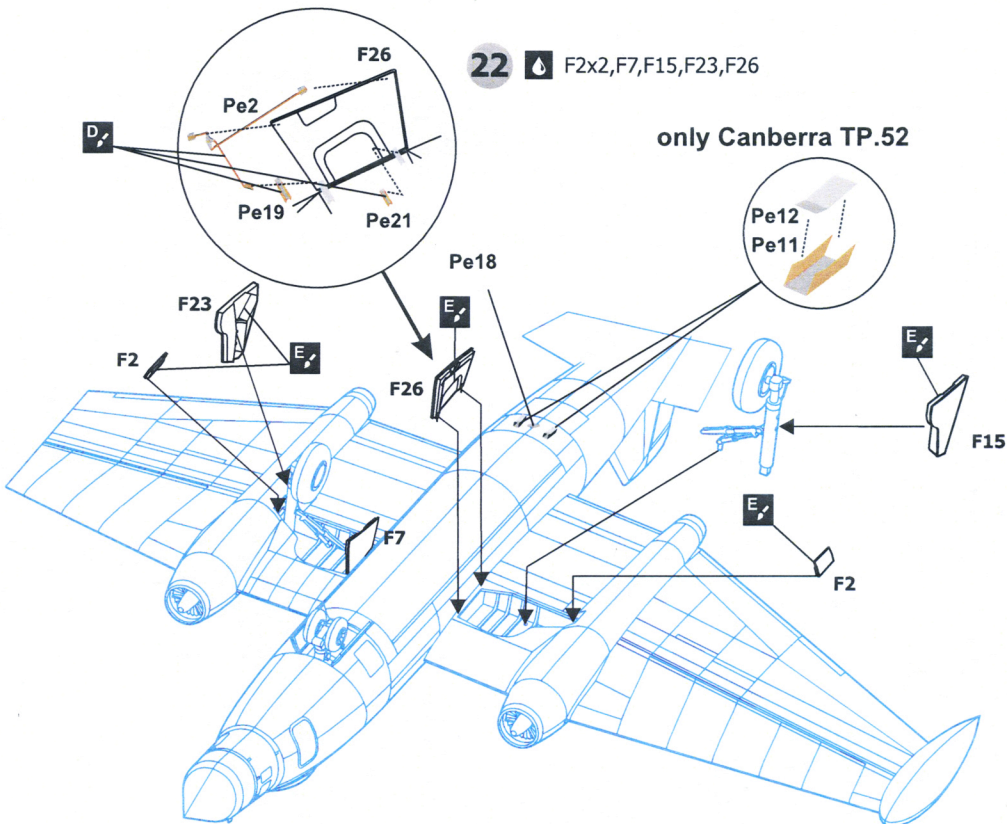

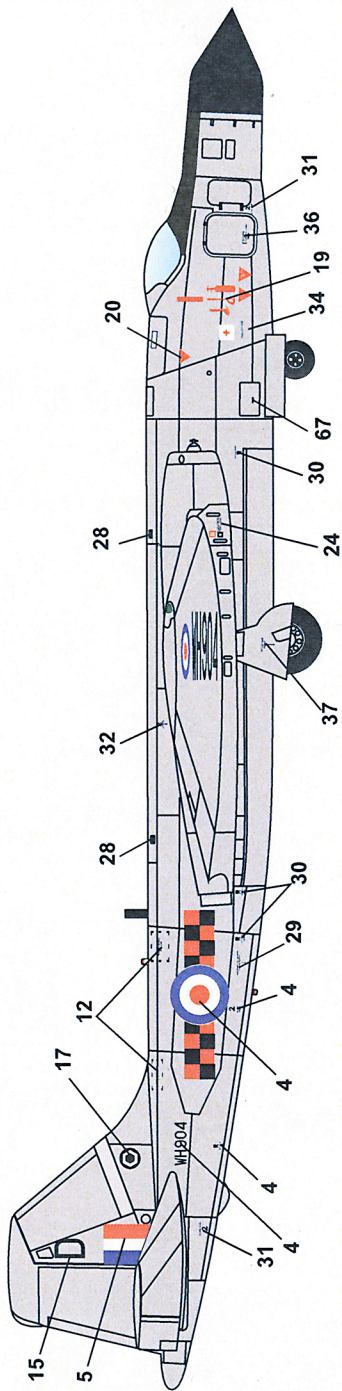
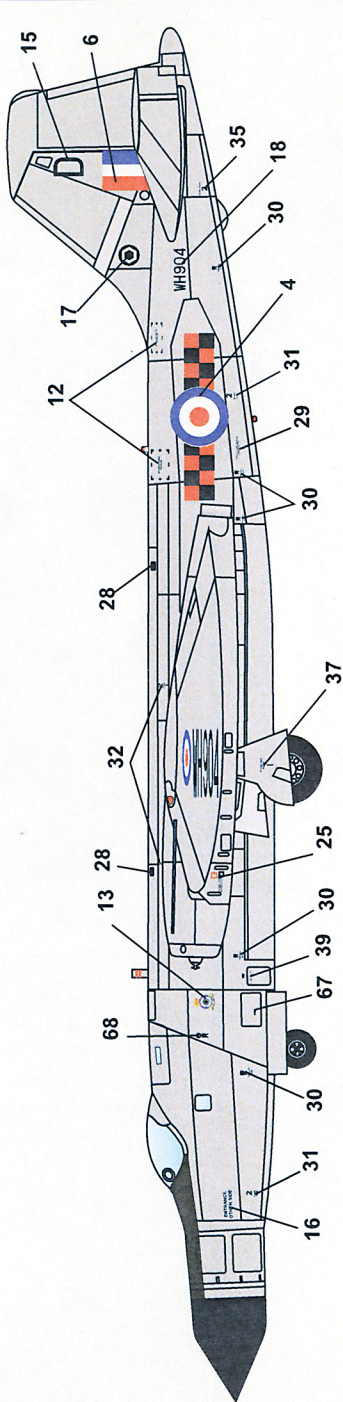

**English Electric Canberra T.19  
85 Squadron, RAF Binbrook**



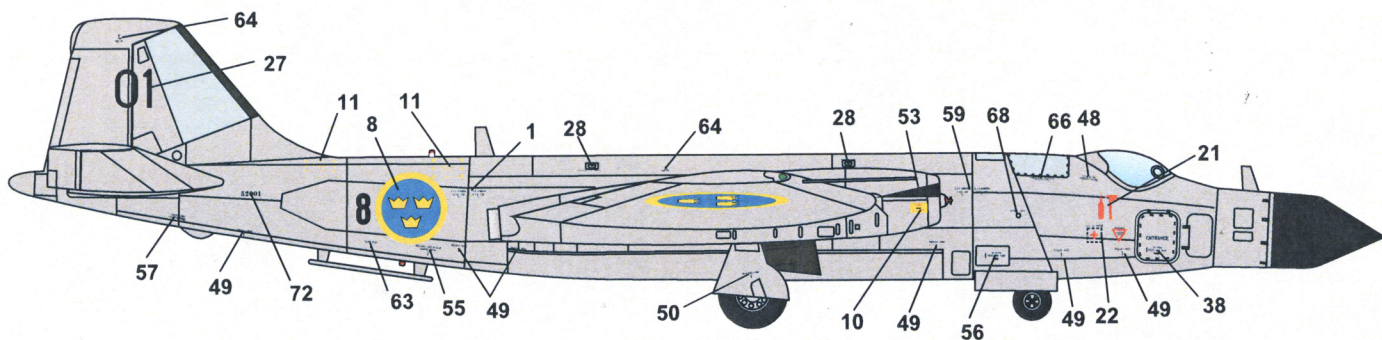
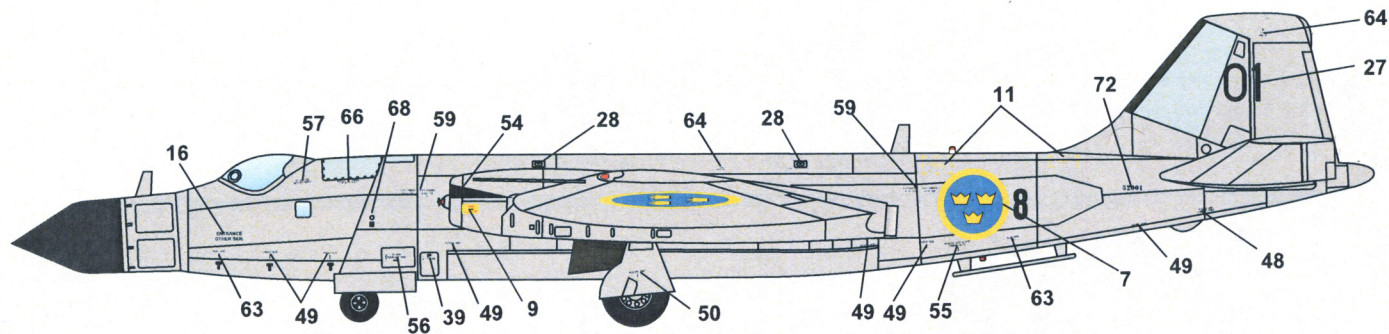

English Electric Canberra T.11(TP.52)  
Swedish Air Force, 1960

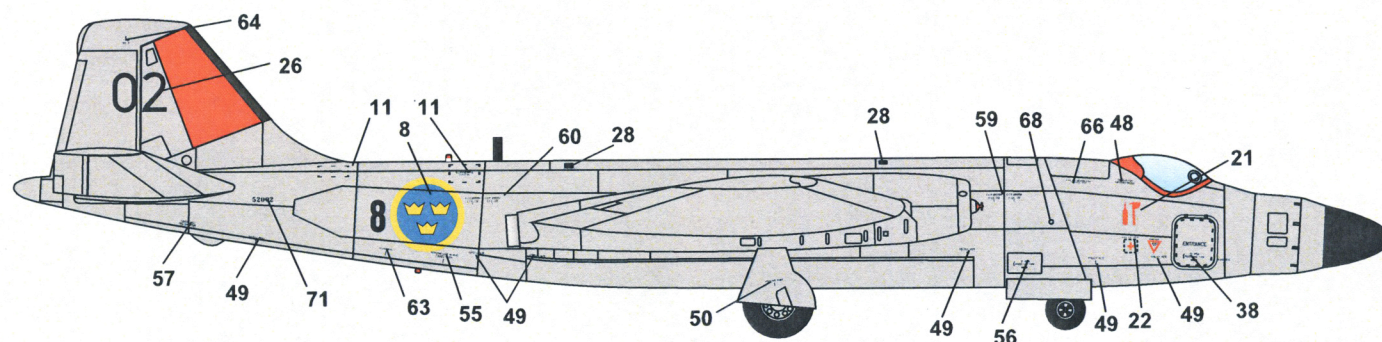
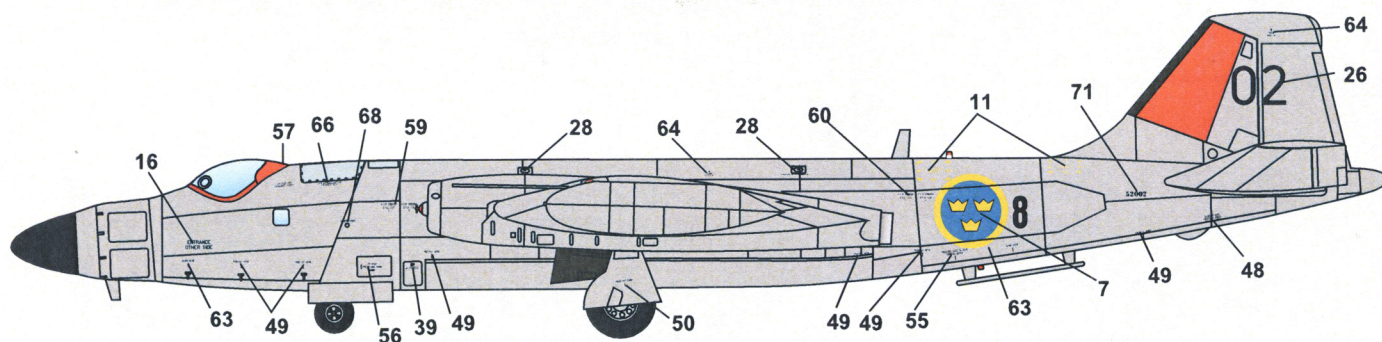

English Electric Canberra T.11(TP.52)  
Swedish Air Force, 1960



