

1/48 SCALE

For Tamiya kit# 61038  
and Hasegawa kit # 09121

Yellowhammer  
Models.

#Y48-07 Hellcat Killers

N1K1-JA SHIDEN  
N1K2-J SHIDEN KAI

**N1K1-JA SHIDEN** 341ST AIR GROUP

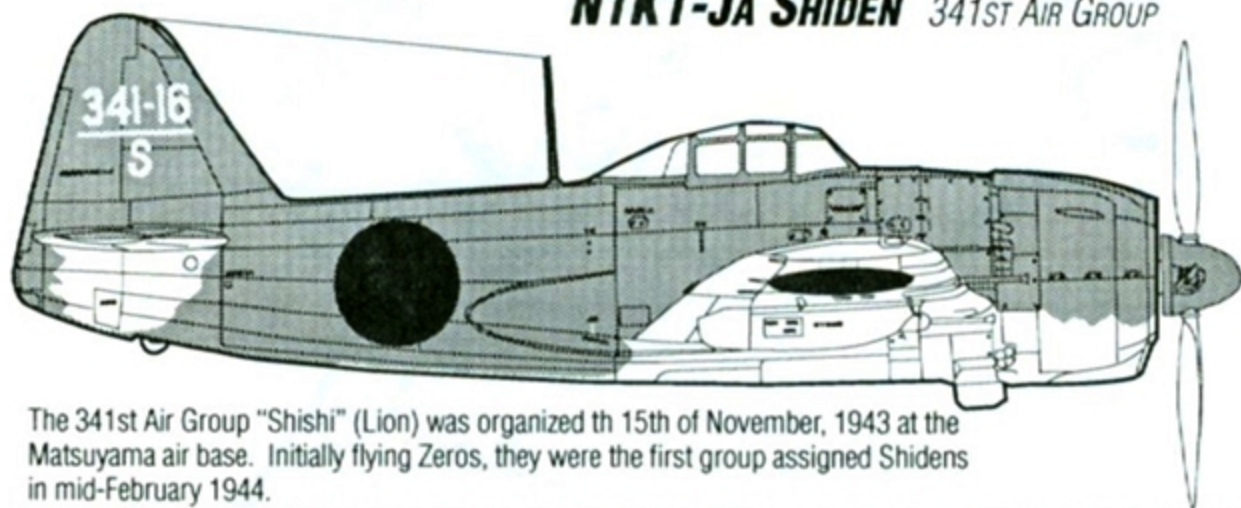

The 341st Air Group "Shishi" (Lion) was organized th 15th of November, 1943 at the Matsuyama air base. Initially flying Zeros, they were the first group assigned Shidens in mid-February 1944.

The group experienced many technical difficulties with the landing gear and engines which reduced their effectiveness. After a move to Mabalacat air Base at Luzon, the Phillipines, the group was heavily engaged against superior American forces and was nearly wiped out by January 9th, 1945 when they flew their last mission.

**N1K2-J SHIDEN KAI** 343RD AIR GROUP (LT. KANNO'S A/C)

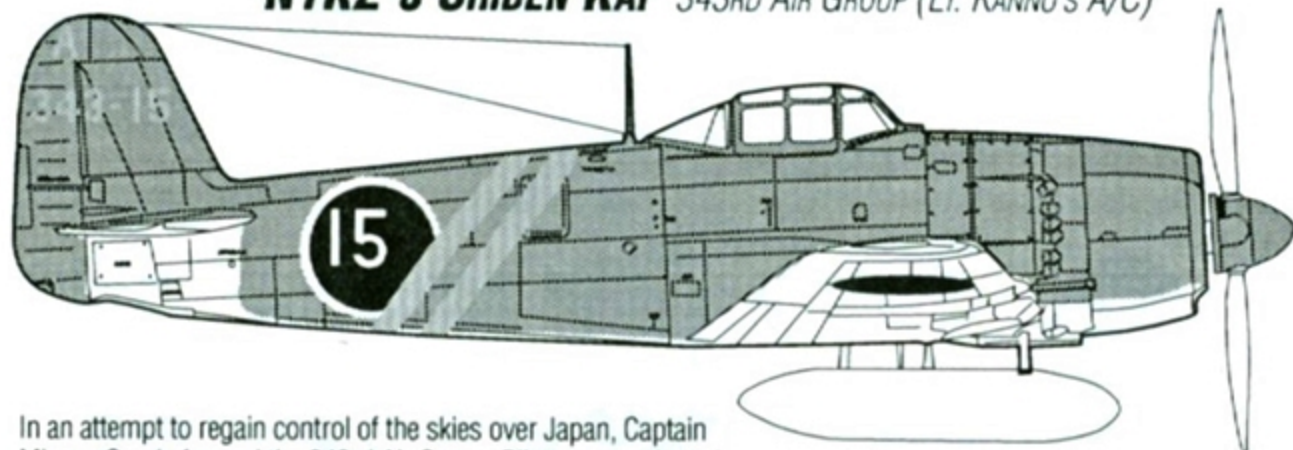

In an attempt to regain control of the skies over Japan, Captain Minoru Genda formed the 343rd Air Group. Pilots were selected from the most experienced personnel from several existing groups. Three Hikoti (squadrons) were formed; 301, 701, and 407.

The Shinsen-gumi (Elite Guard) 301 Hikotai was commanded by Lt. Naoshi Kanno, a veteran of the 341st Air Group in the Phillipines, where he was credited with 25 kills. The aircraft on this sheet is one of the first 200 production Shiden Kais distinguished by the larger vertical stabilizer. Lt. Kanno was lost in action on August 8, 1945 when one of his wing cannon exploded during an attack on a B-24 formation.

**N1K2-J SHIDEN KAI** #6 PROTOTYPE

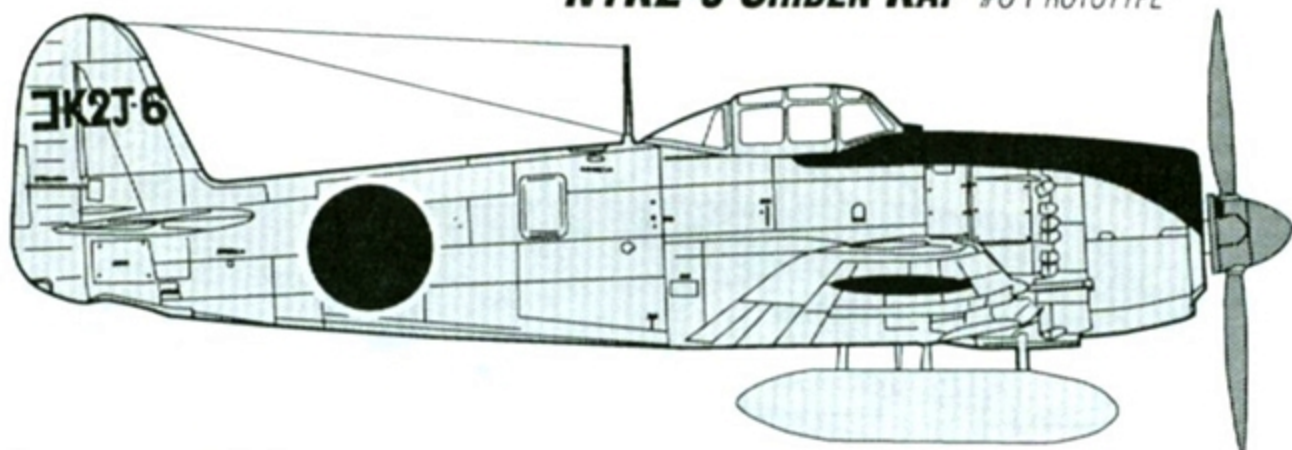

Prototype #6 N1K2-J (Kawanishi 96) received by the Navy/Air Force Testing Station in Yokuska, Japan in December 1944.

## N1K1-JA SHIDEN 341ST AIR GROUP

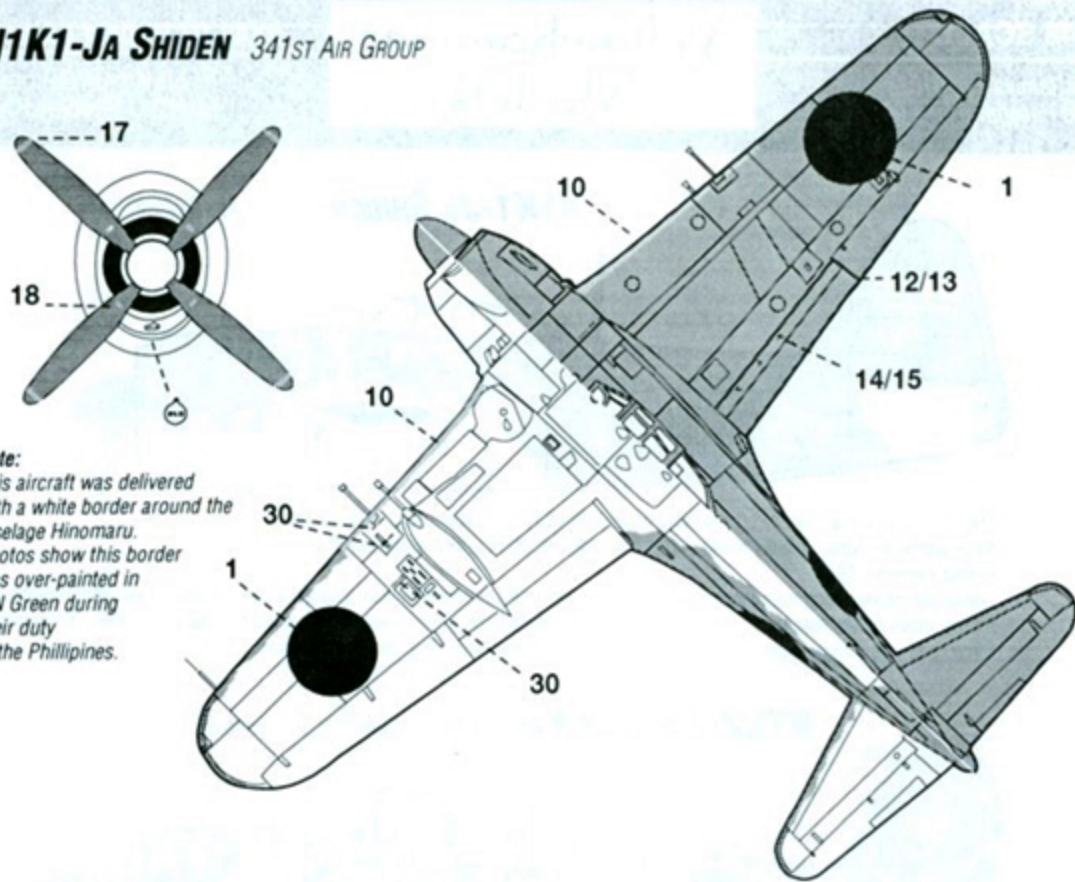

**Note:**  
This aircraft was delivered with a white border around the fuselage Hinomaru. Photos show this border was over-painted in IJN Green during their duty in the Philippines.

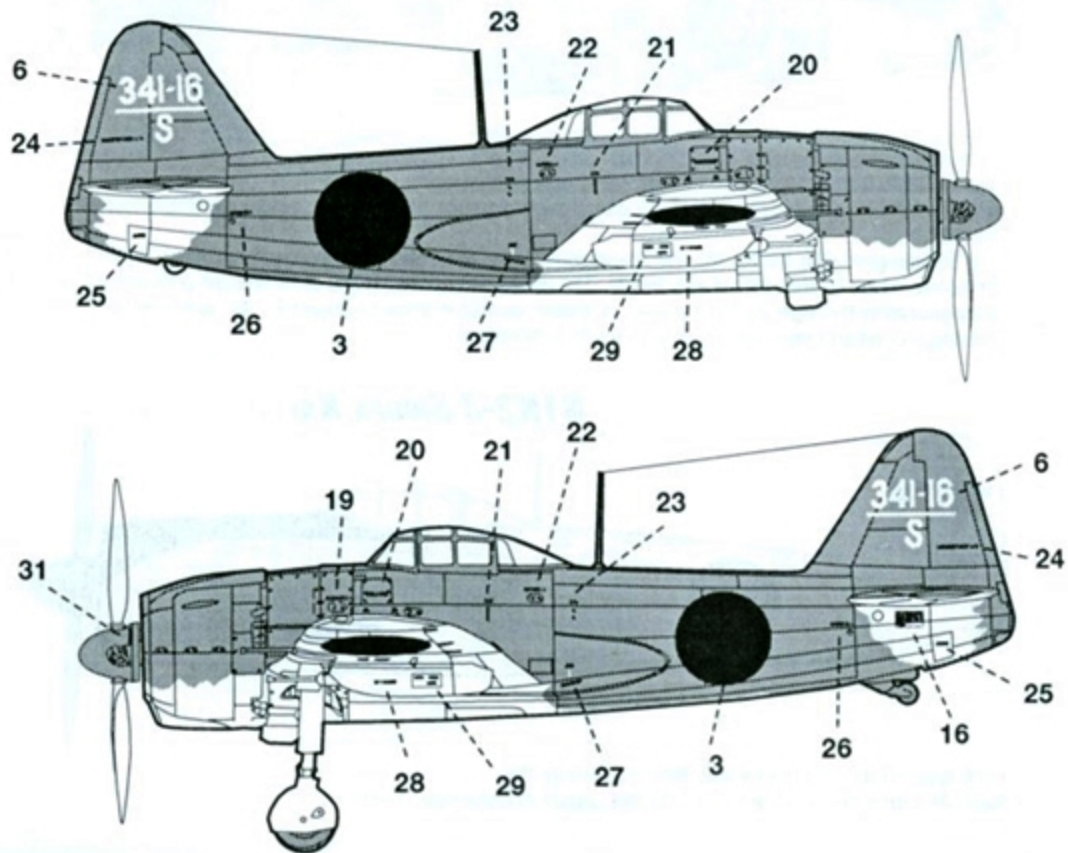

## N1K2-J SHIDEN KAI 343RD AIR GROUP (LT. KANNO'S A/C)

These markings are based on a photo taken April 10, 1945 at Matsuyama Air Base, Shikoku when Lt. Kanno was preparing to depart on a mission.

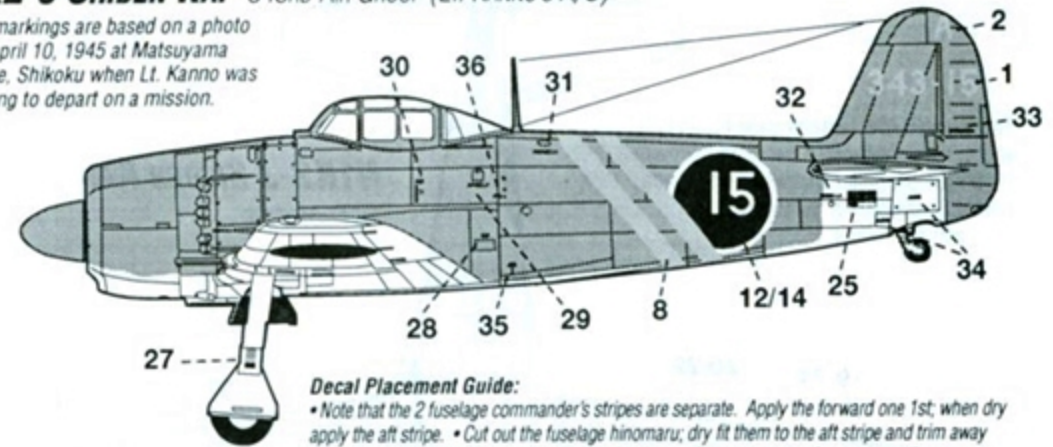

### Decal Placement Guide:

• Note that the 2 fuselage commander's stripes are separate. Apply the forward one 1st; when dry apply the aft stripe. • Cut out the fuselage hinomaru; dry fit them to the aft stripe and trim away the overlap (see drawings). • Note that the fuselage stripes are purposely uneven as they were on the actual aircraft.

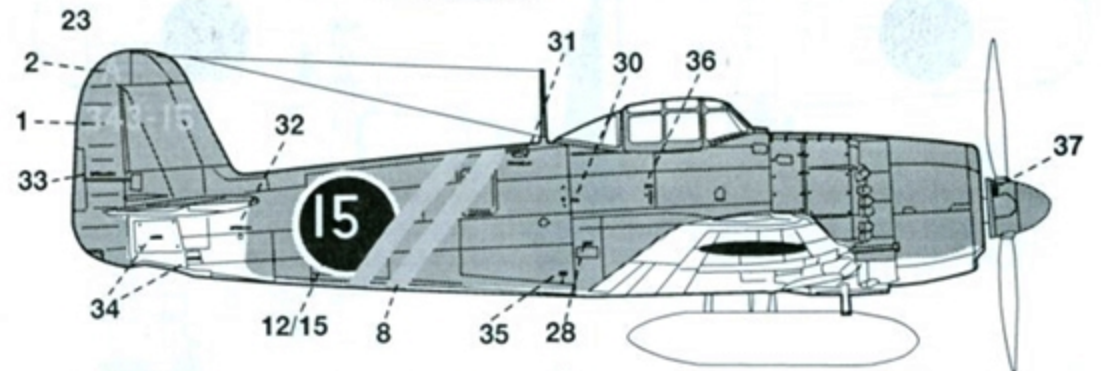

**Note:** Cut the clear film away from the opening on the wing recognition stripes. Paint the cannon fairings to match this stripe before you apply the decal. Paint the A/C according to kit instructions.

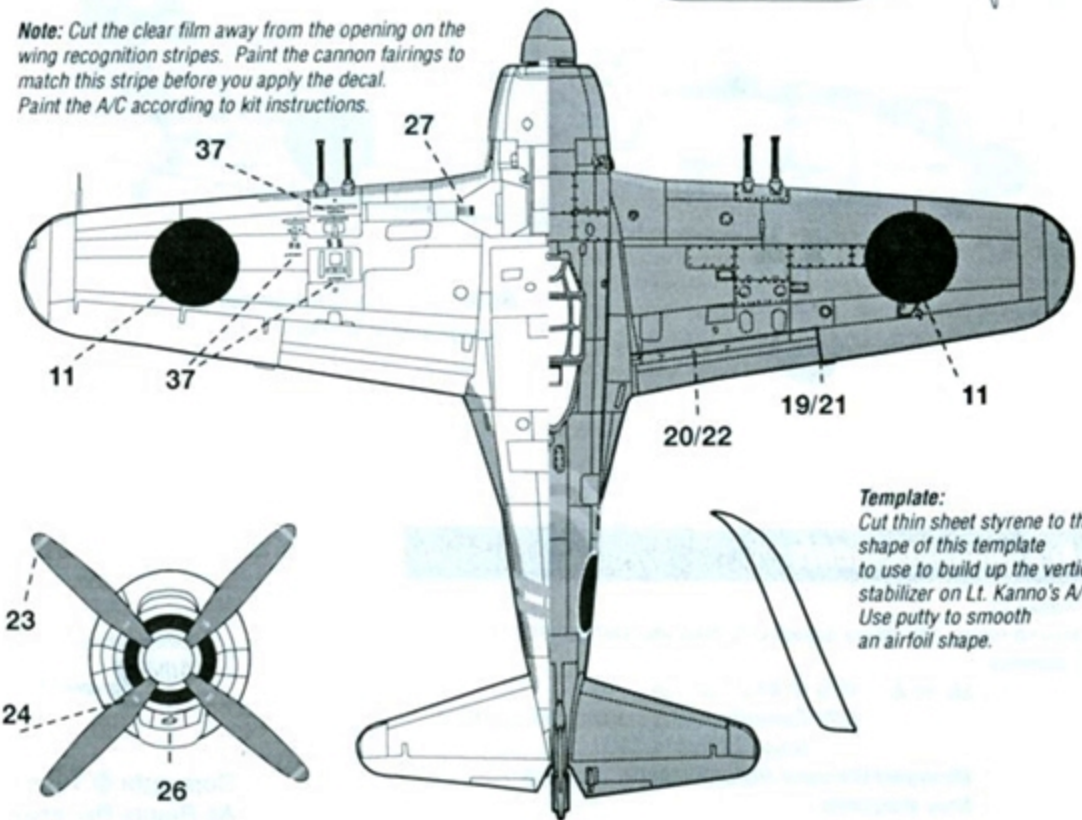

**Template:**  
Cut thin sheet styrene to the shape of this template to use to build up the vertical stabilizer on Lt. Kanno's A/C. Use putty to smooth an airfoil shape.

This aircraft is overall orange FS 31400 with a black anti-glare panel and brown FS 30061 propeller blades and spinner. Use kit instructions for the rest of the painting details.

## N1K2-J SHIDEN KAI

#6 PROTOTYPE

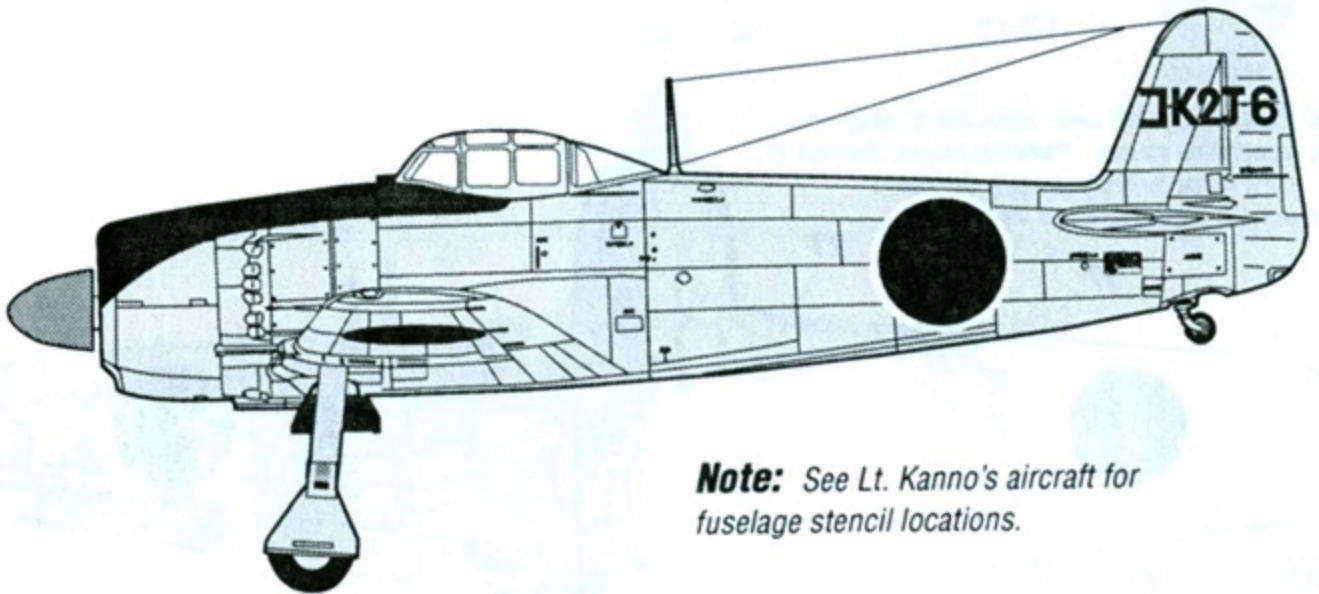
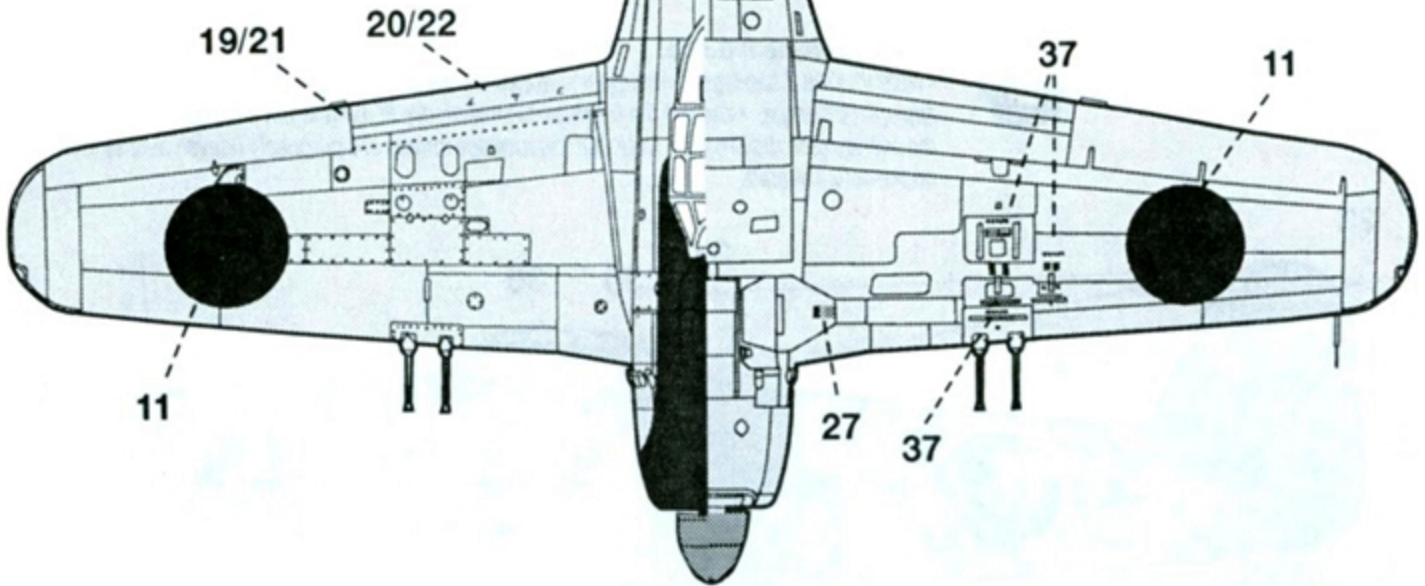

**Note:** See Lt. Kanno's aircraft for fuselage stencil locations.

### Acknowledgements:

Thanks to:  
Yasuno Handa and Henry Sakaida for their valuable assistance.

References:

Model Art #304 N1K1/2 "George"  
#272 Camouflage and markings of Japanese  
Navy Fighters in WWII  
*Illustrated Warplane History-Imperial Japanese  
Navy Warplanes*

Custom Artwork By

**AIM-9**graphics™

Copyright © 1995  
All Rights Reserved