

Arado Ar 198

Firma Arado zvolila koncepci jednomotorového hornoplošniku aby zajistila posádce dobrý výhled do všech stran. Konstrukce letounu byla kovová, poháněl jej hvězdicový motor BMW Bramo 223 A Fafnir o výkonu 900k. Ze začátku byla dávána právě tomuto projektu přednost, avšak v dubnu 1937 byly ke zkouškám objednány současně tři prototypy Ar 198 i Fw 189. První, ještě nevyzbrojený prototyp Ar 198 V1 vzletl na jaře 1938. V průběhu zkoušek se ukázaly jeho nedobré letové vlastnosti a i jeho výkony zůstaly za zadanými požadavky. Veškeré další práce na tomto typu byly zastaveny, dokonce ani nebyl dokončen druhý prototyp s kompletní výzbrojí. Do sériové výroby byl zařazen konkurenční Fw 189.

The firm Arado chose the conception of a single-engined high-wing monoplane in order to assure the crew of a good view to all directions. The design of the aircraft was metallic, it was driven by a radial BMW Bramo 223 A Fafnir engine with 900 HP output. At beginning this project was preferred, but in April 1937 also three prototypes of Ar 198 as well as of Fw 189 were ordered for testing. The first not yet armed prototype Ar 198 V1 made its maiden flight in spring 1938. During the tests its rather bad flying properties turned up and also its technical performance fell short of the submitted demands. All further work on this type was stopped, even the second prototype with complete armament was not finished. For series production the competing Fw 189 was destined.

A Arado Ar 198
jaro 1938
spring of 1938

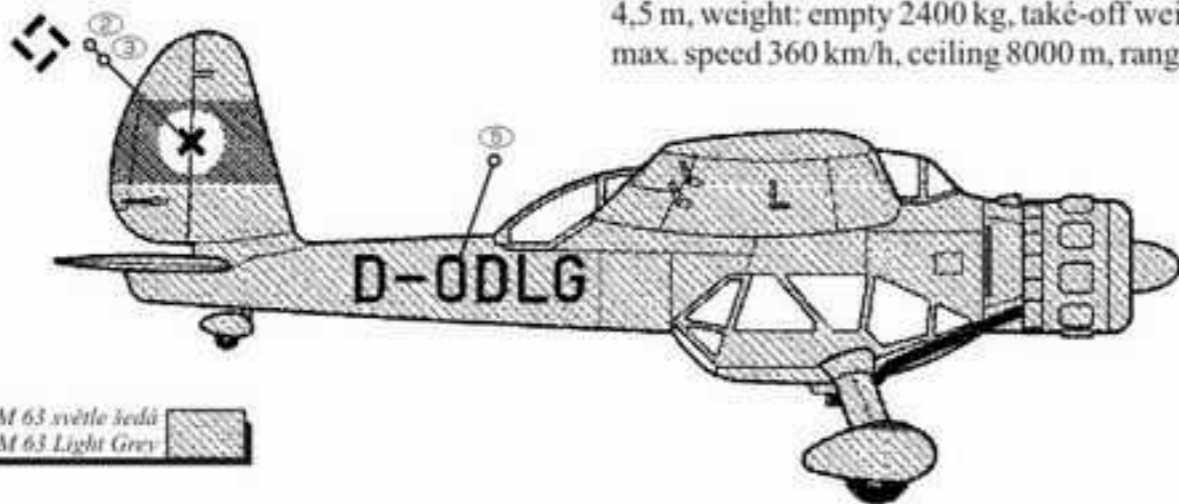
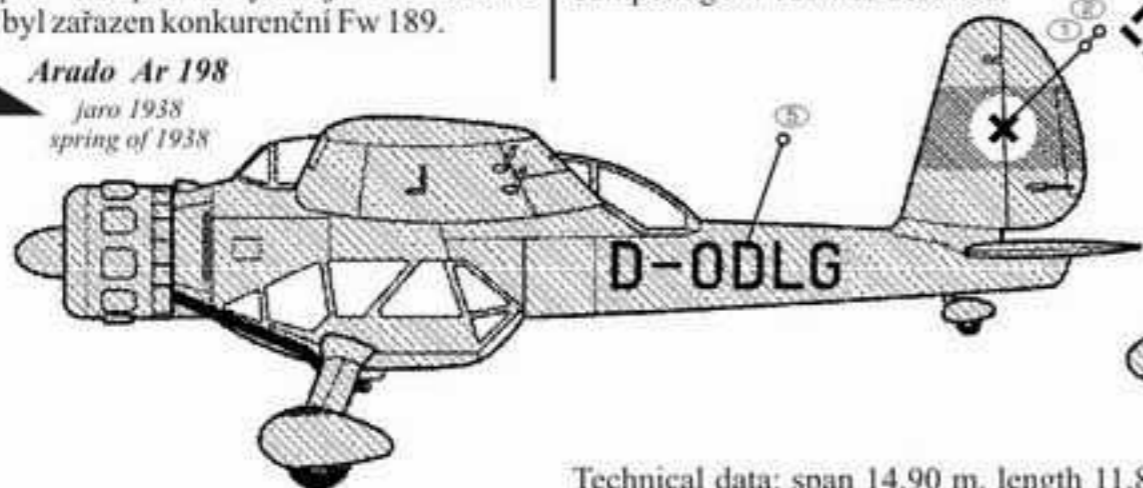

Technical data: span 14,90 m, length 11,80 m, height 4,5 m, weight: empty 2400 kg, take-off weight 3034 kg, max. speed 360 km/h, ceiling 8000 m, range 1100 km.

RLM 63 světle šedá
RLM 63 Light Grey

RLM 70 černozeleňá - listy vrtule
RLM 70 Black Green - propeller blades

