



Sopwith Baby

07 202

1/72 SCALE PLASTIC KIT

PLASTIC PARTS

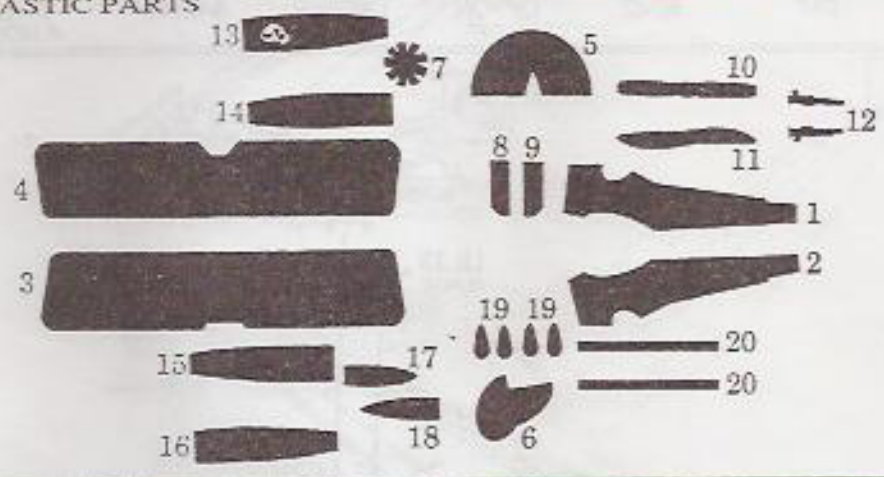
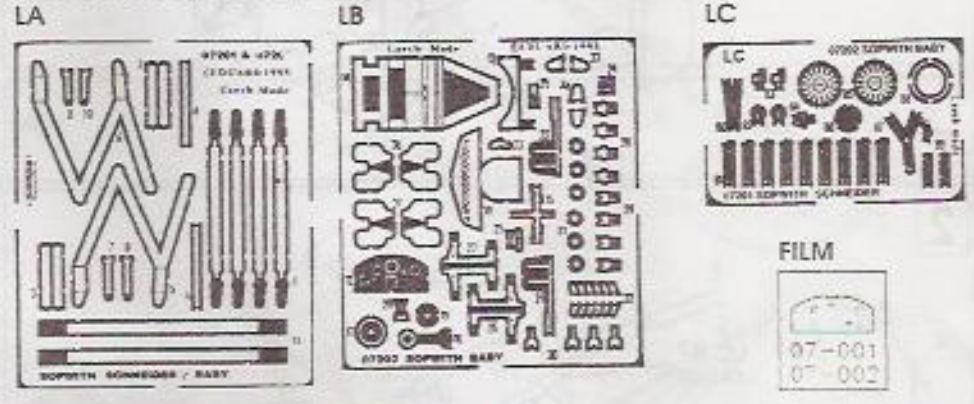
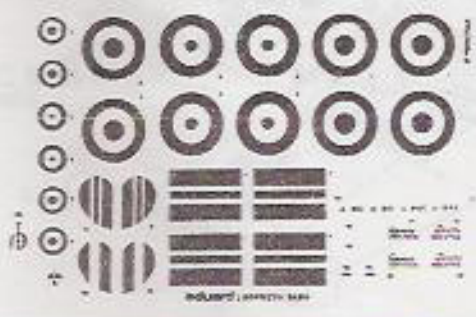

PHOTO ETCHED BRASS PARTS



DECALS



CAUTION !

PHOTO ETCHED PARTS CAN ONLY BE GLUED WITH CYANOACRYLATE GLUE. WORK IN A WELL VENTILATED AREA. DO NOT INHALE VAPORS SINCE THESE CAN BE HARMFUL. WASH YOUR HANDS AFTER USING. FIND A DOCTOR ON AN INDISPOSITION.



CUT



BEND



OPTION



OPPOSITE SIDE



BALLAST



DRILL A HOLE

1

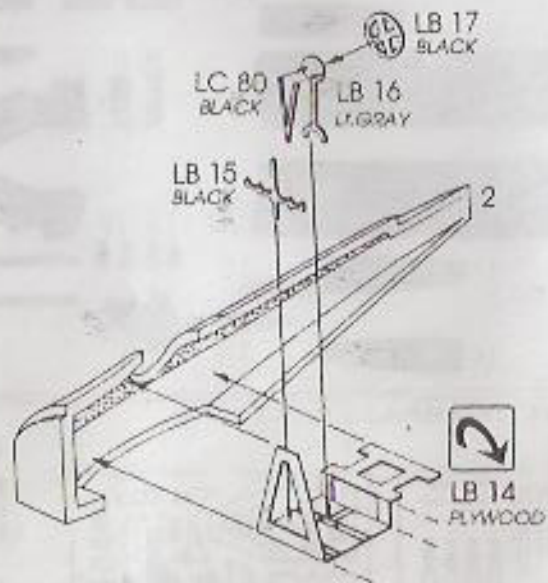

2

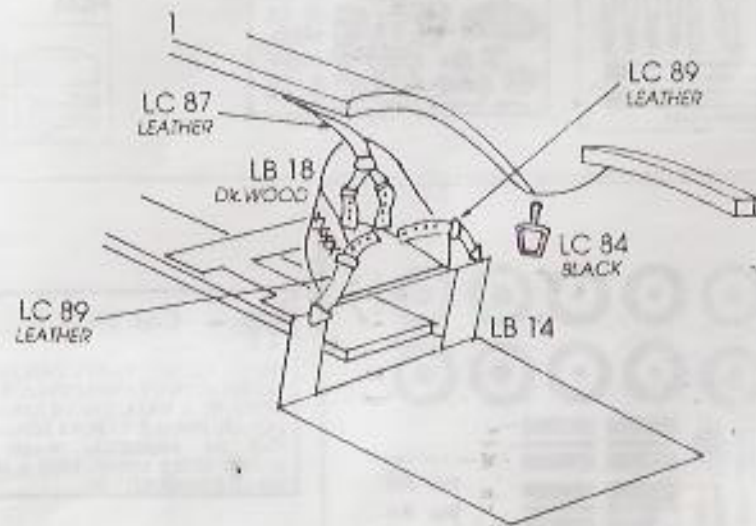

3

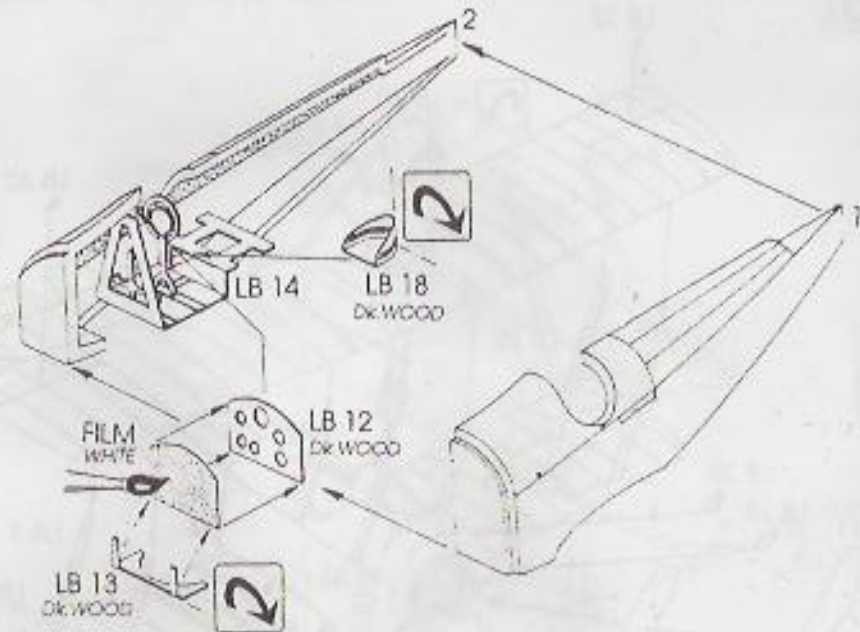

4

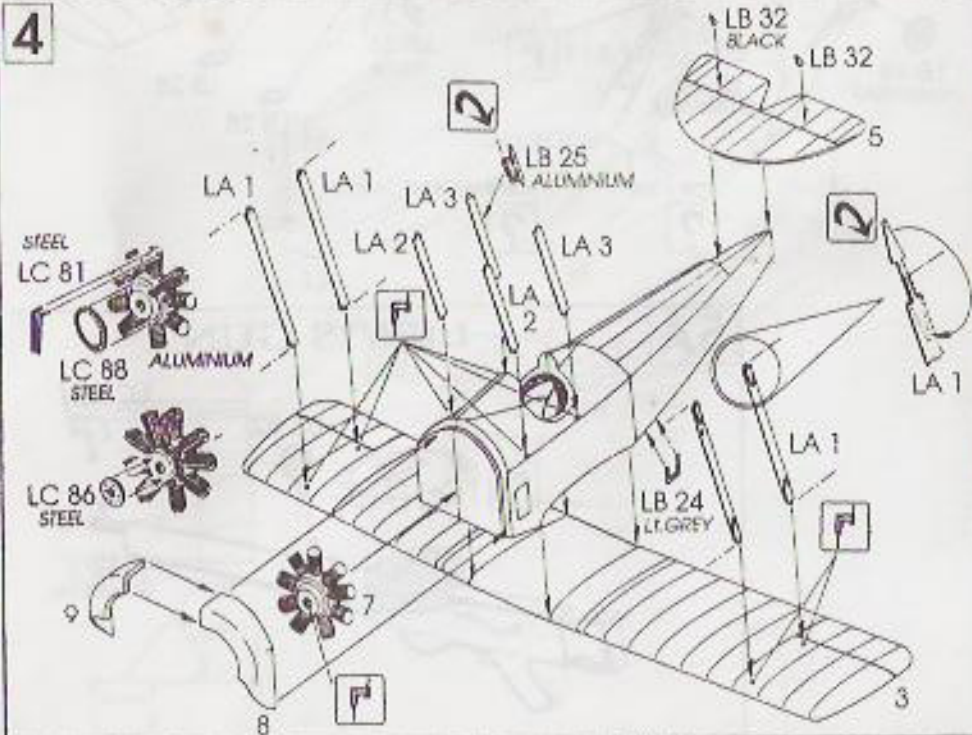

5

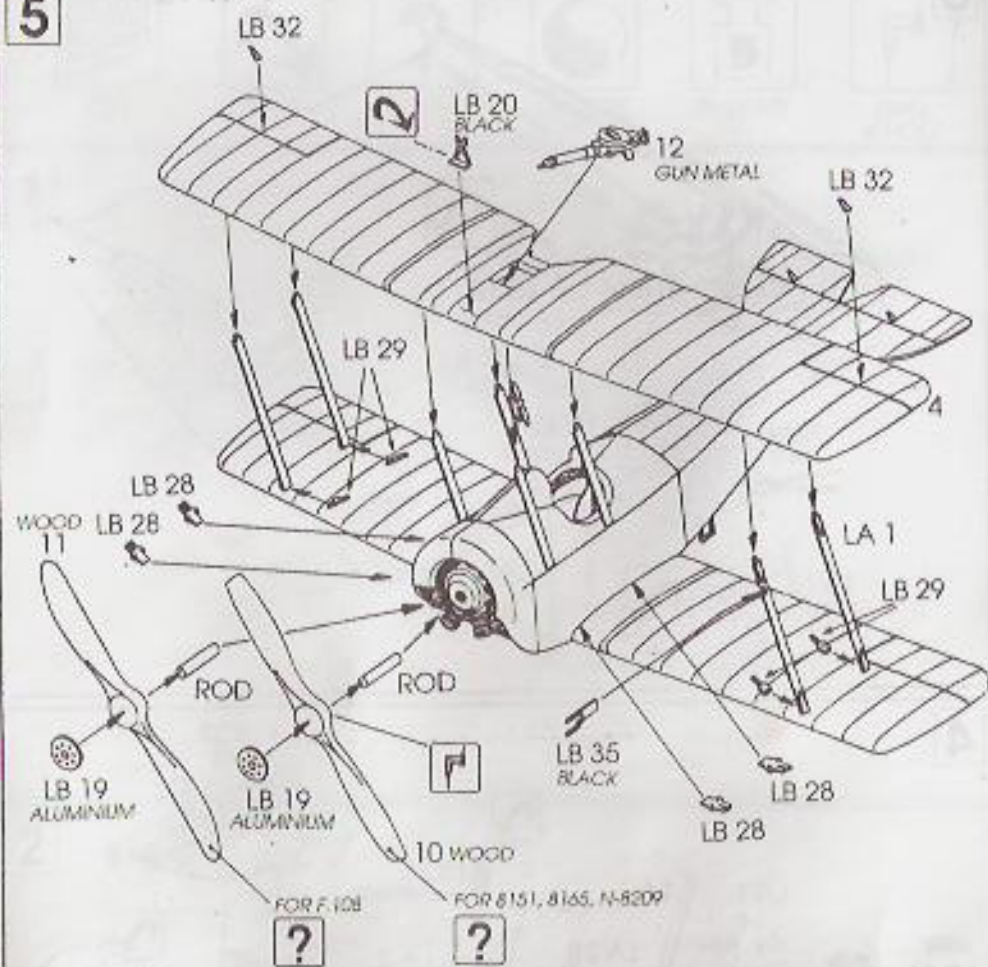

5A

LEWIS GUN

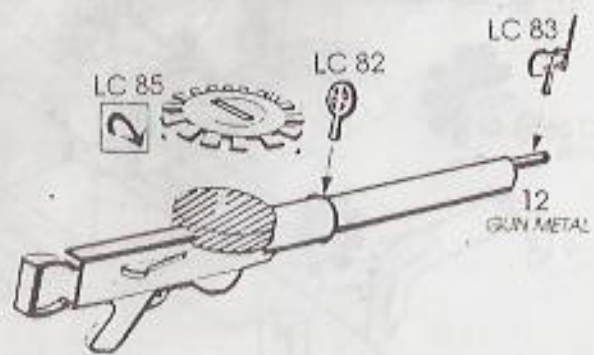

6

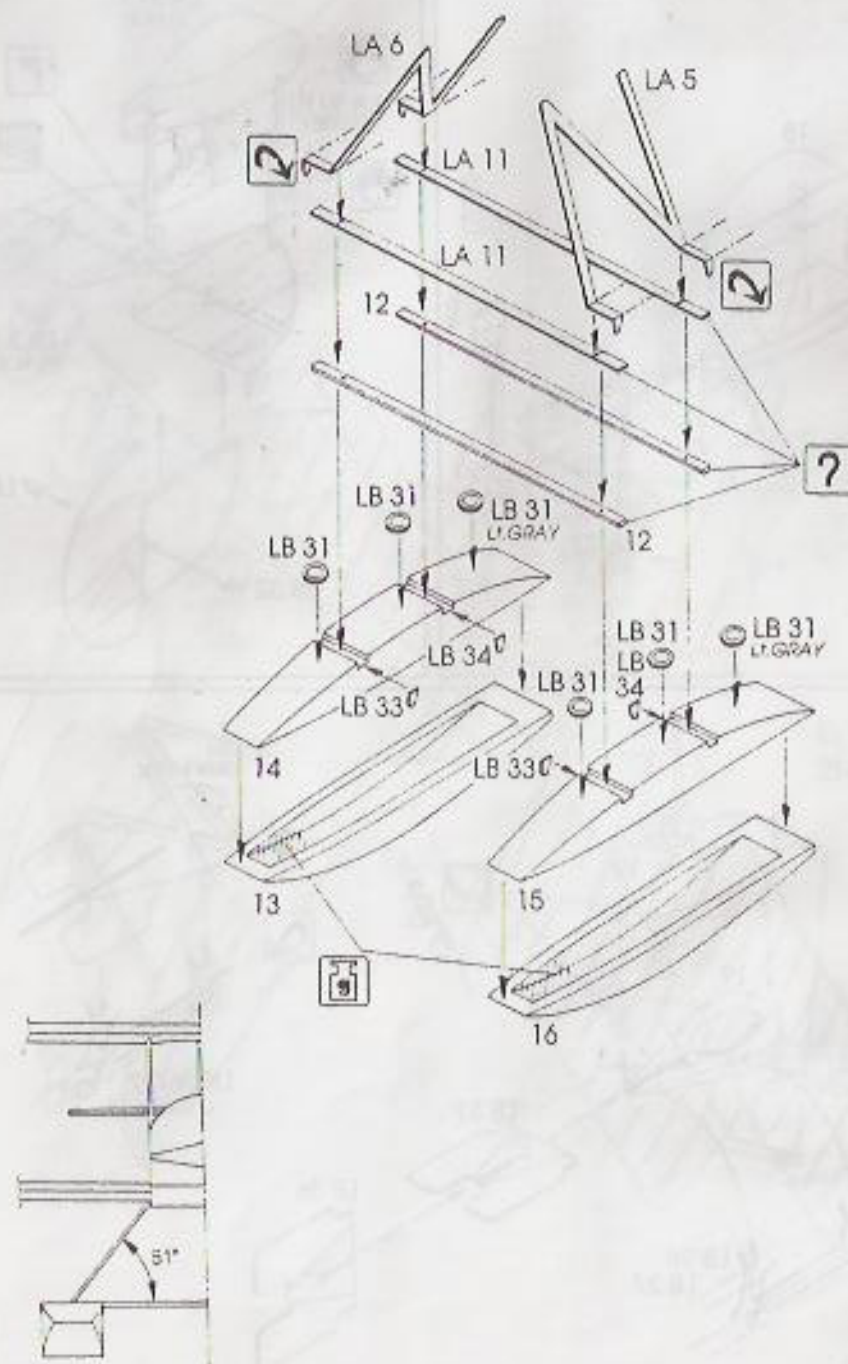

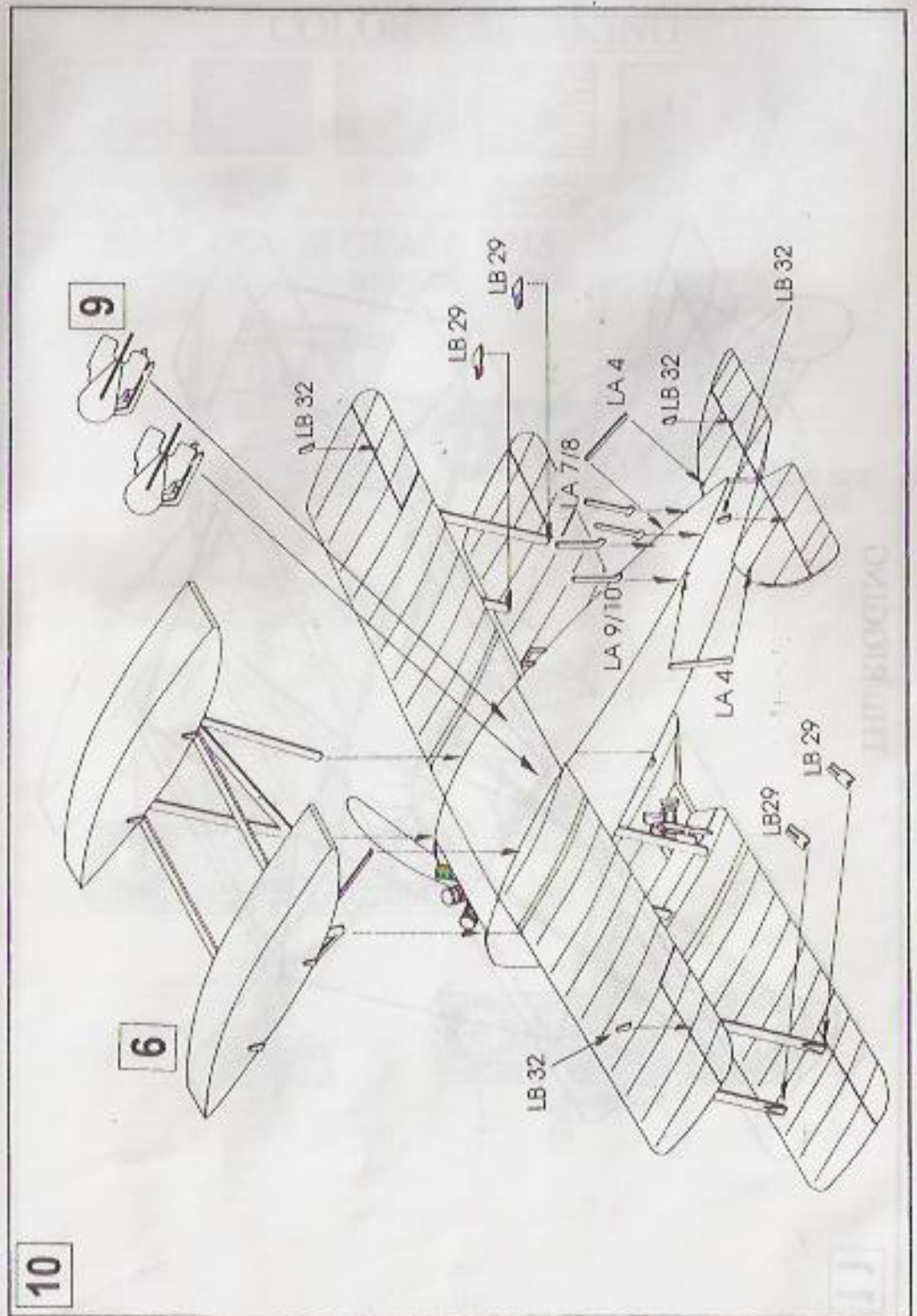
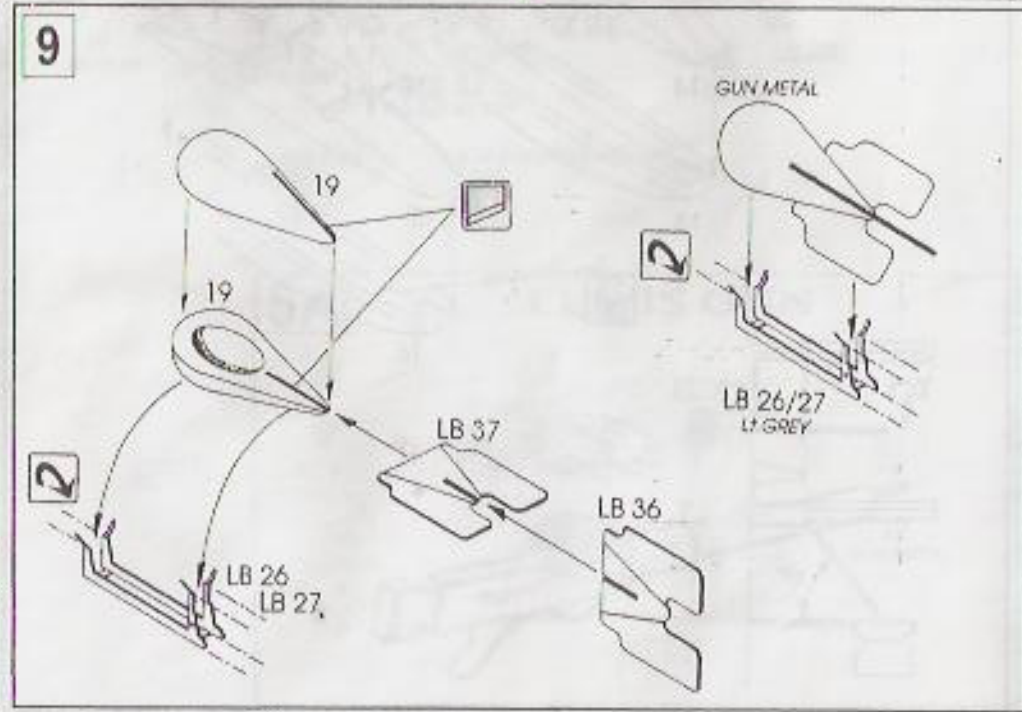
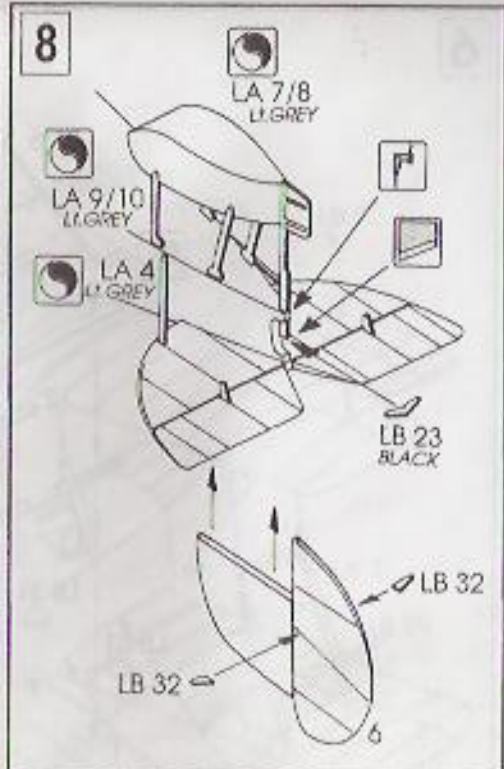
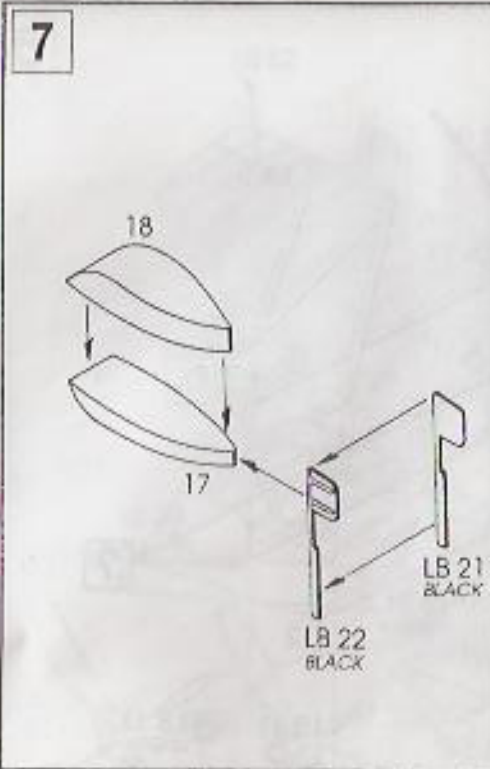

THE RIGGING

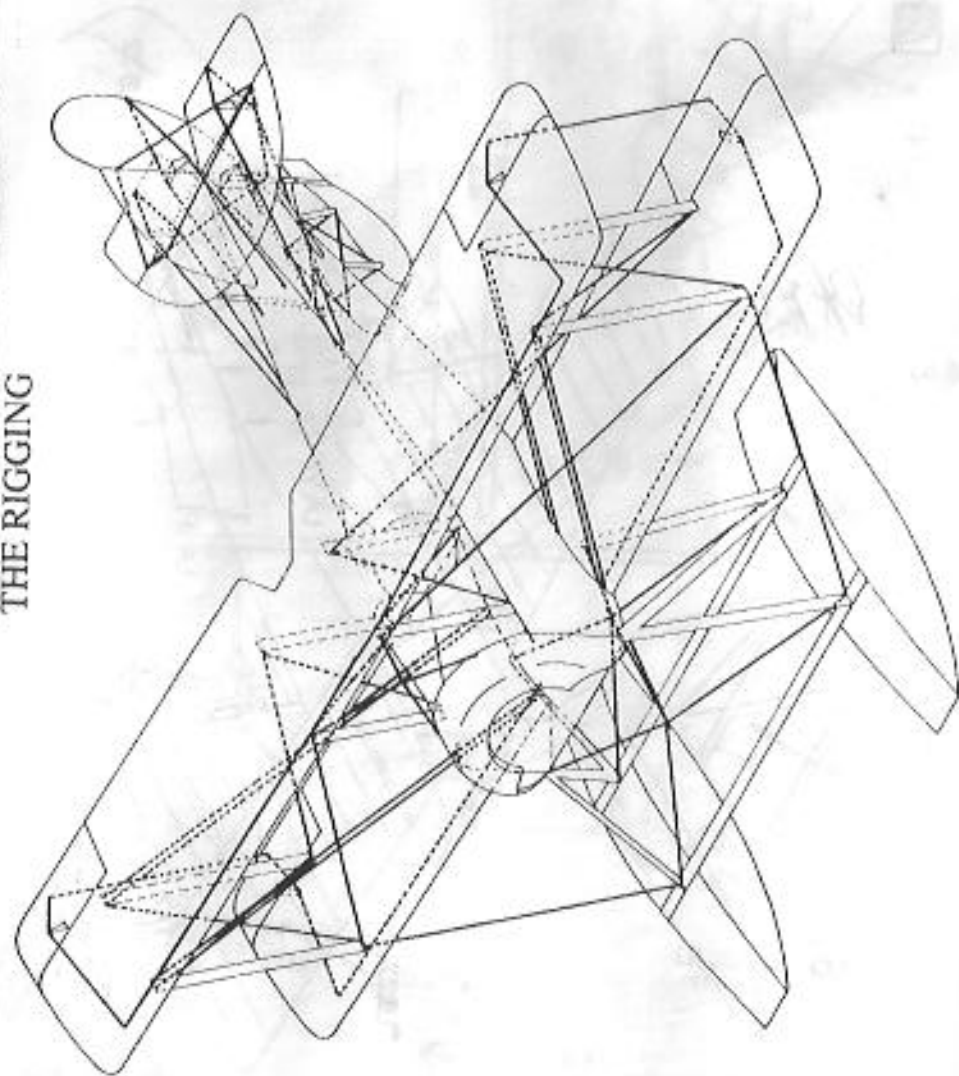

11

COLOR & MARKING

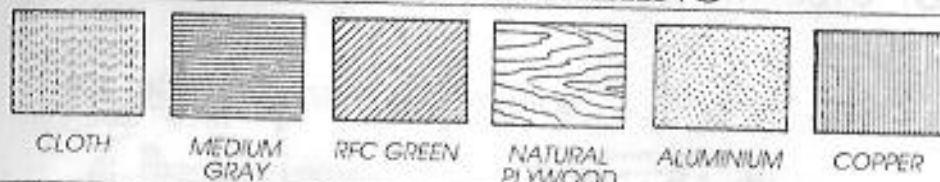

A 8151, ISLE OF GRAIN, 1916

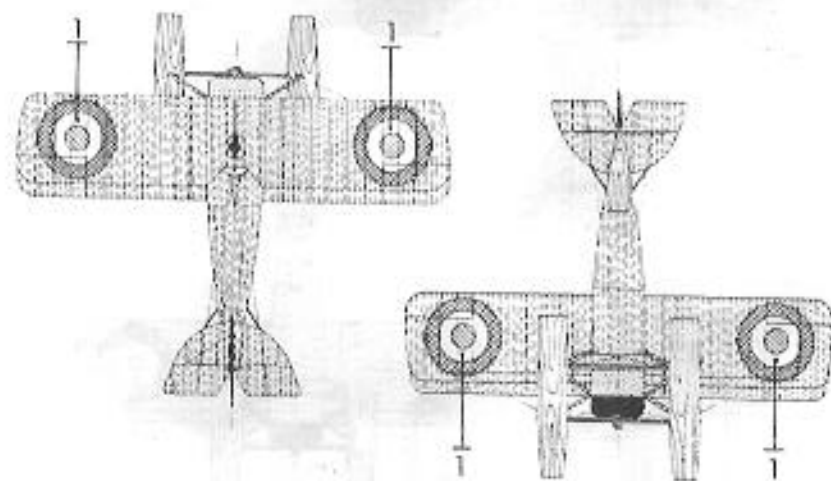
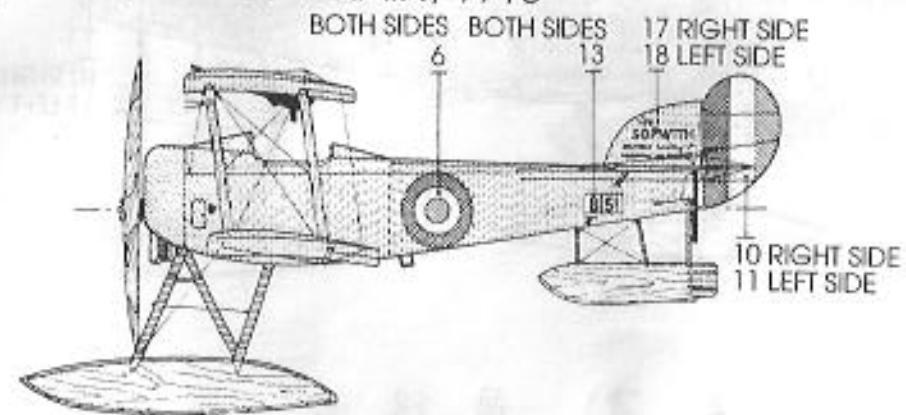

B 8165, RNAS FELIXTOWE, EARLY 1916

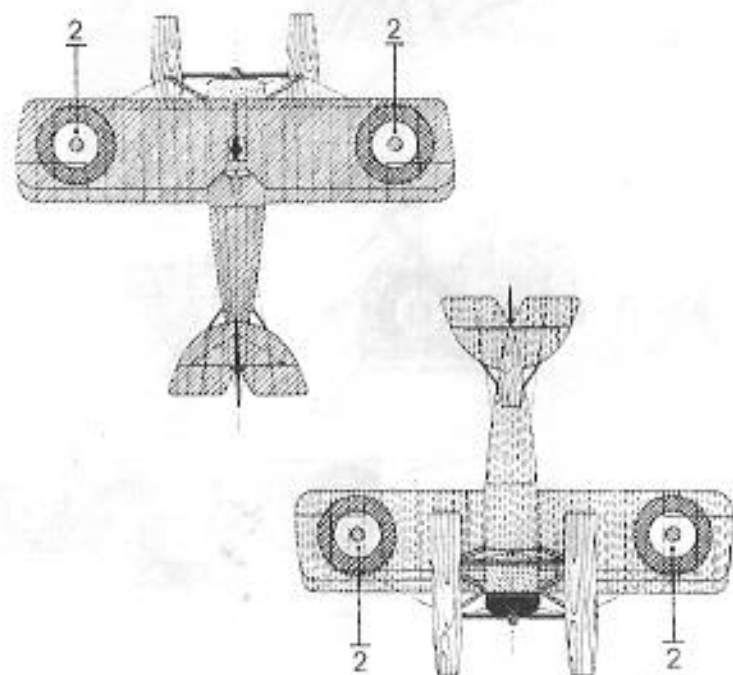
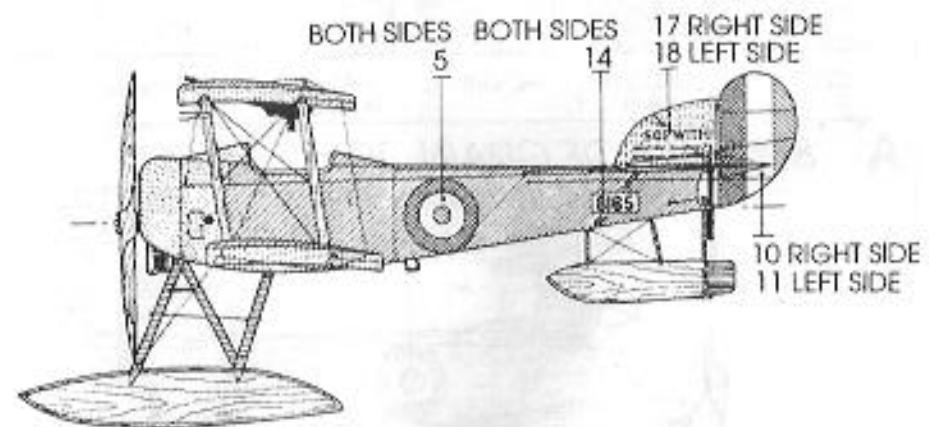

C N-8209, TESTED BY U.S. NAVY, MAY 1918

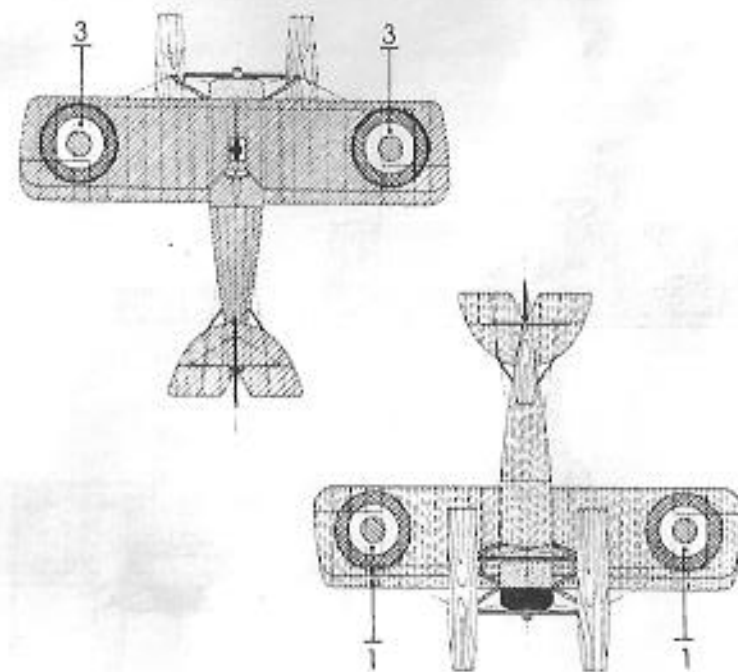
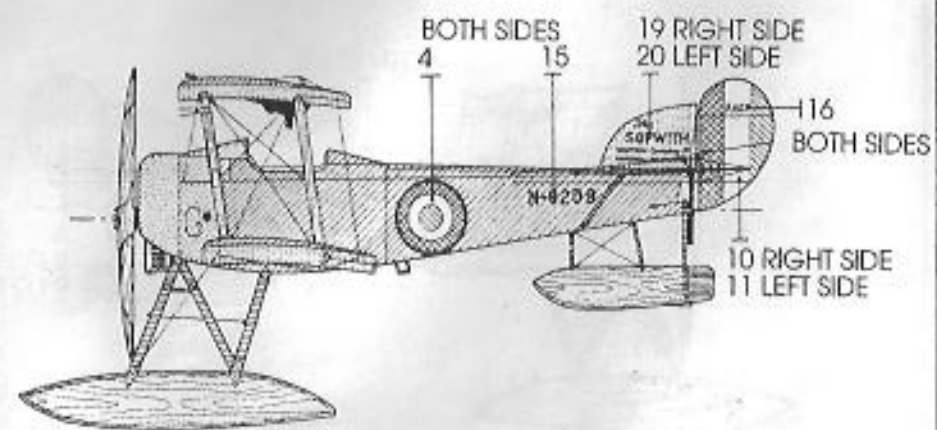

D F.108, NORWEGIAN A.F., EARLY 1920's

