

de Havilland Dominie/Rapide in Military Service



For the best results these decals should be applied to a gloss surface such as provided by either Xtracolor or Xtracrylix paints. Cut out the decal required and soak in warm water until the decal is released from the backing paper. Wet the area to be decaled with MICRO SET which will help to eliminate air trapped under the decal and position the decal.

After 5 or 10 minutes wet the decal with MICRO SOL which will soften the decal and ensure that it settles down over any surface detail. Allow the decal to dry for at least 12 hours. During this time some wrinkling of the decal may occur, this is normal. Do not touch the decal at this time.

Carefully check for small air bubbles and if there are any prick with a needle and apply a drop of MICRO SOL. After all air bubbles have been eliminated and the decals are dry wash the entire model with water to remove any excess decal adhesive.

When completely dry the whole model should be sprayed with a coat of Xtracolor or Xtracrylix Flat, Satin or Gloss varnish depending on the finish required.

Store in a cool dry place, avoid sunlight, dampness or extremes of temperature and/or humidity.

6311/'2' was finished in Dark Green with Silver lower wing, tailplanes spinners and tailfin. A Red band was applied around the mid fuselage and the wingtips and nose were Red also.

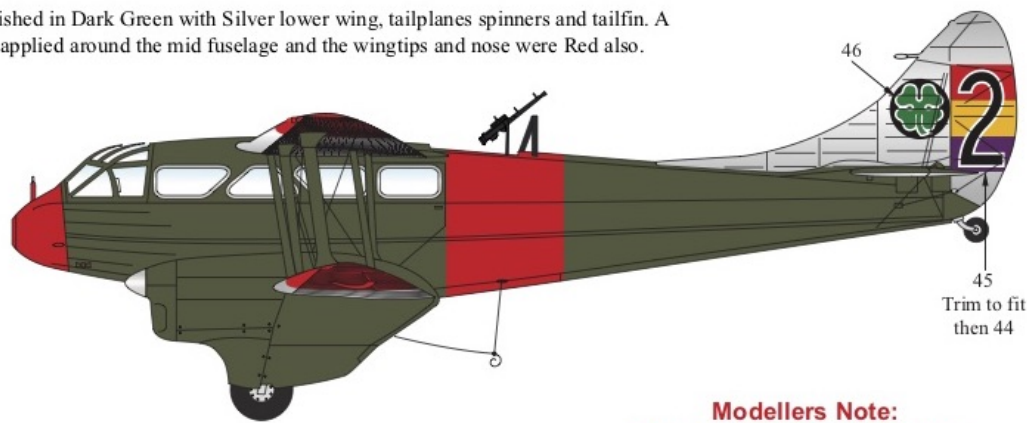

45
Trim to fit then 44

de Havilland Rapide (Military),
 6311/'2'
 of Escuadron 'Alas Rojas'
 Spanish Republican Air Force,
 based in Spain,
 August, 1936.

Modellers Note:
 This Rapide had a blunt nose, extended tailfin fillet, fuselage bomb aimers hatch, dorsal machine gun opening and mail hook fitted.

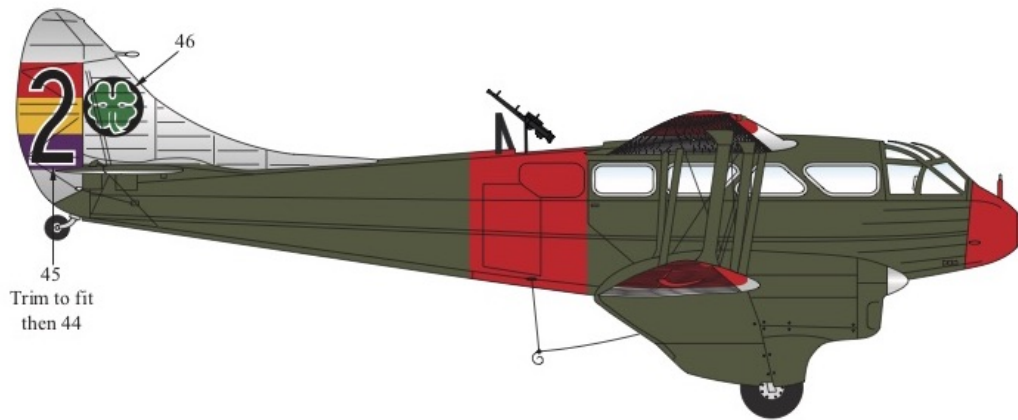

45
Trim to fit then 44

'1402' was finished in an overall Silver finish with Azure Blue front engine cowlings. The spinners were Silver with Night backplates.

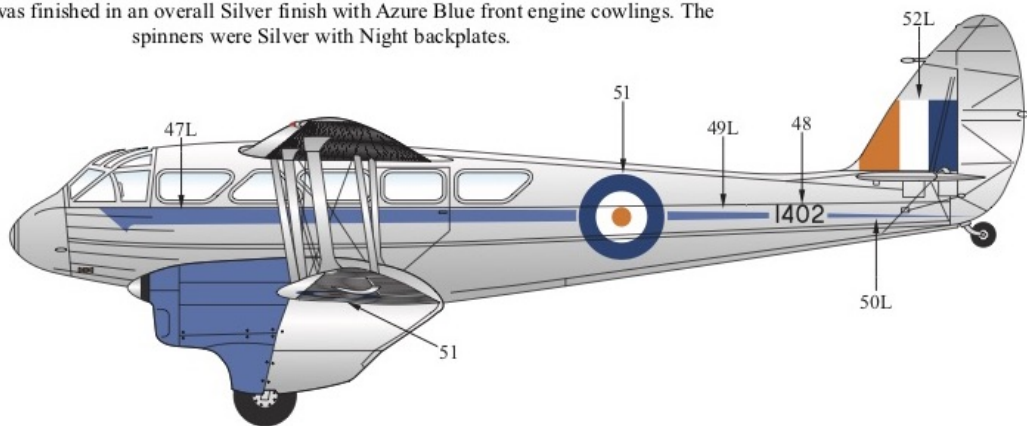

de Havilland Rapide,
 '1402',
 of 61 Squadron,
 South African Air Force,
 1940.

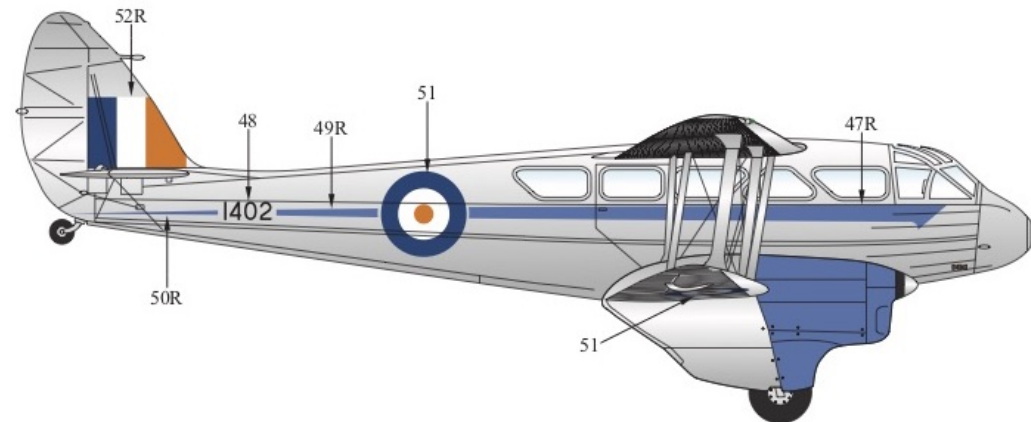

Xtracolor Paints

- X002 BS381C:450 Dark Earth
- X009 Middle Stone
- X012 BS381C:642 Night Black
- X018 BS381C:285 NATO Green
- X026 Azure Blue
- X029 BS381C:369 Light Stone
- X105 FS13531 Sand
- X112 ANA 613 Olive Drab
- X133 FS16270 Neutral Gray
- X149 FS15622 Pale Blue
- X260 RAL 7035 Lichtgrau
- X405 White
- X501 Silver

Paints:

The colours used on these aircraft can be found in the Xtracolor (prefix number with X) and Xtracrylix (prefix number with XA1) range of paints.

Xtracrylix Paints

- XA1002 BS381C:450 Dark Earth
- XA1009 Middle Stone
- XA1012 BS381C:642 Night Black
- XA1026 Azure Blue
- XA1112 ANA 613 Olive Drab
- XA1133 FS16270 Neutral Gray

03' was finished in Sand over Light Blue undersides. The spinners were White.

de Havilland Dominie,
 '03'
 of Israeli Air Force,
 based in Israel,
 1948.

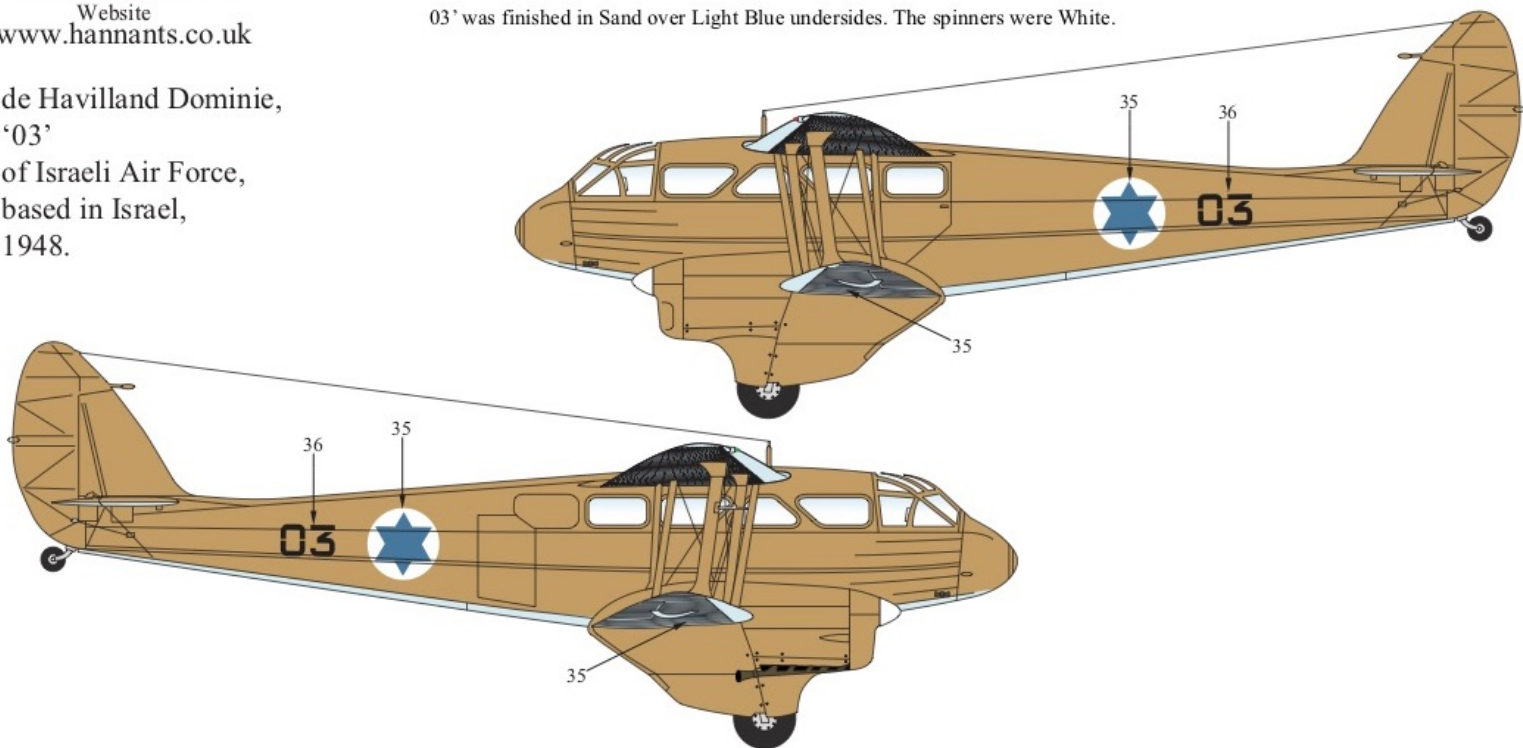

de Havilland Dominie,
 'V.3' / 'Gelderland',
 of 1 Transport Vliegtuig Afdeling,
 Lucht Strijdkrachten,
 Royal Netherlands Air Force,
 Netherlands,
 1949.

'V.3' was finished in a NATO Dark Green & NATO Dark Grey
 disruptive camouflage over Light Grey undersides. The spinners were NATO Dark Grey.

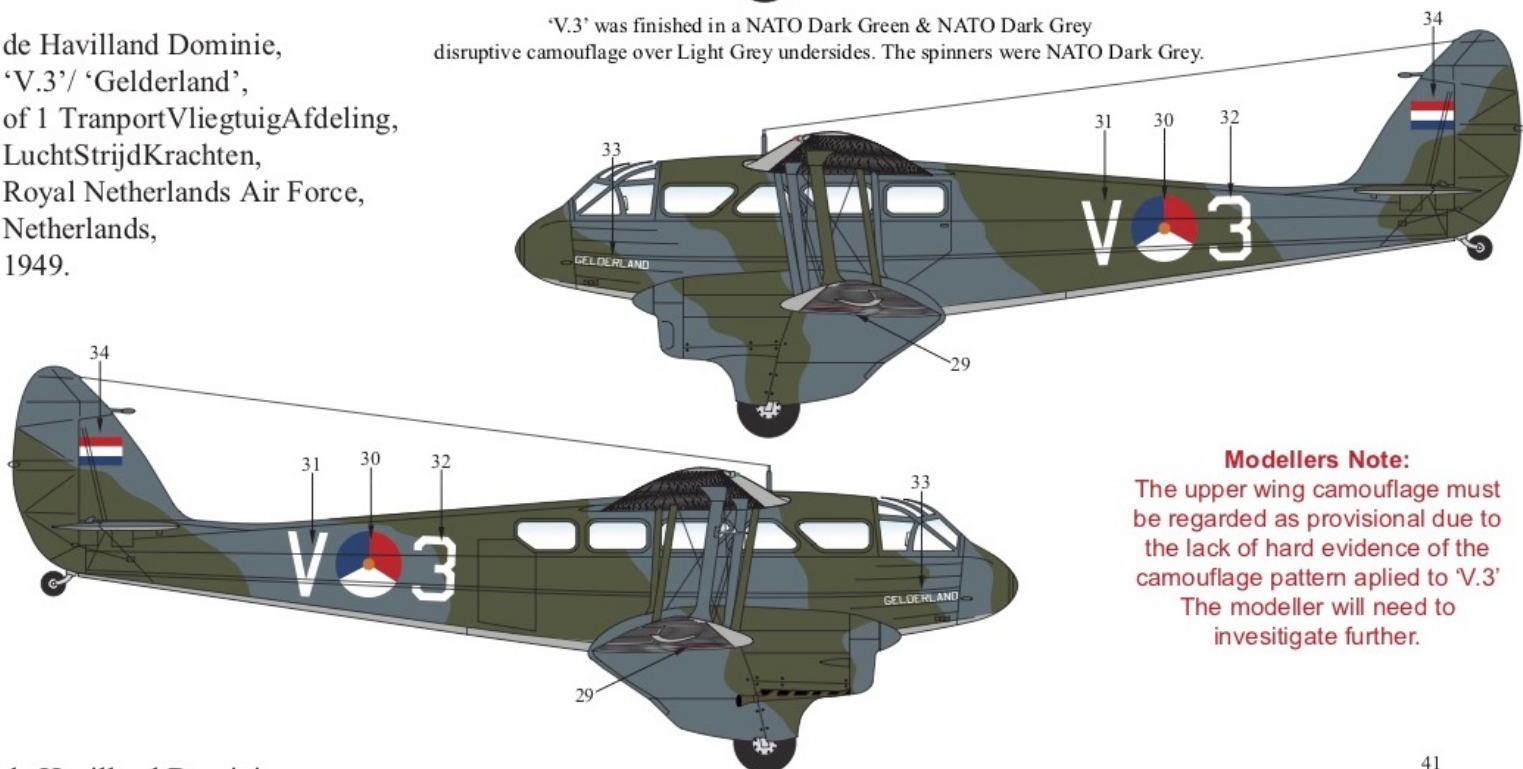

Modellers Note:
 The upper wing camouflage must
 be regarded as provisional due to
 the lack of hard evidence of the
 camouflage pattern applied to 'V.3'
 The modeller will need to
 investigate further.

de Havilland Dominie,
 '2307',
 of Portuguese Air Force,
 Portugal,
 1952.

2307 was finished in overall Silver, the engine nacelles and interplane struts were
 Blue. The spinners were Silver.

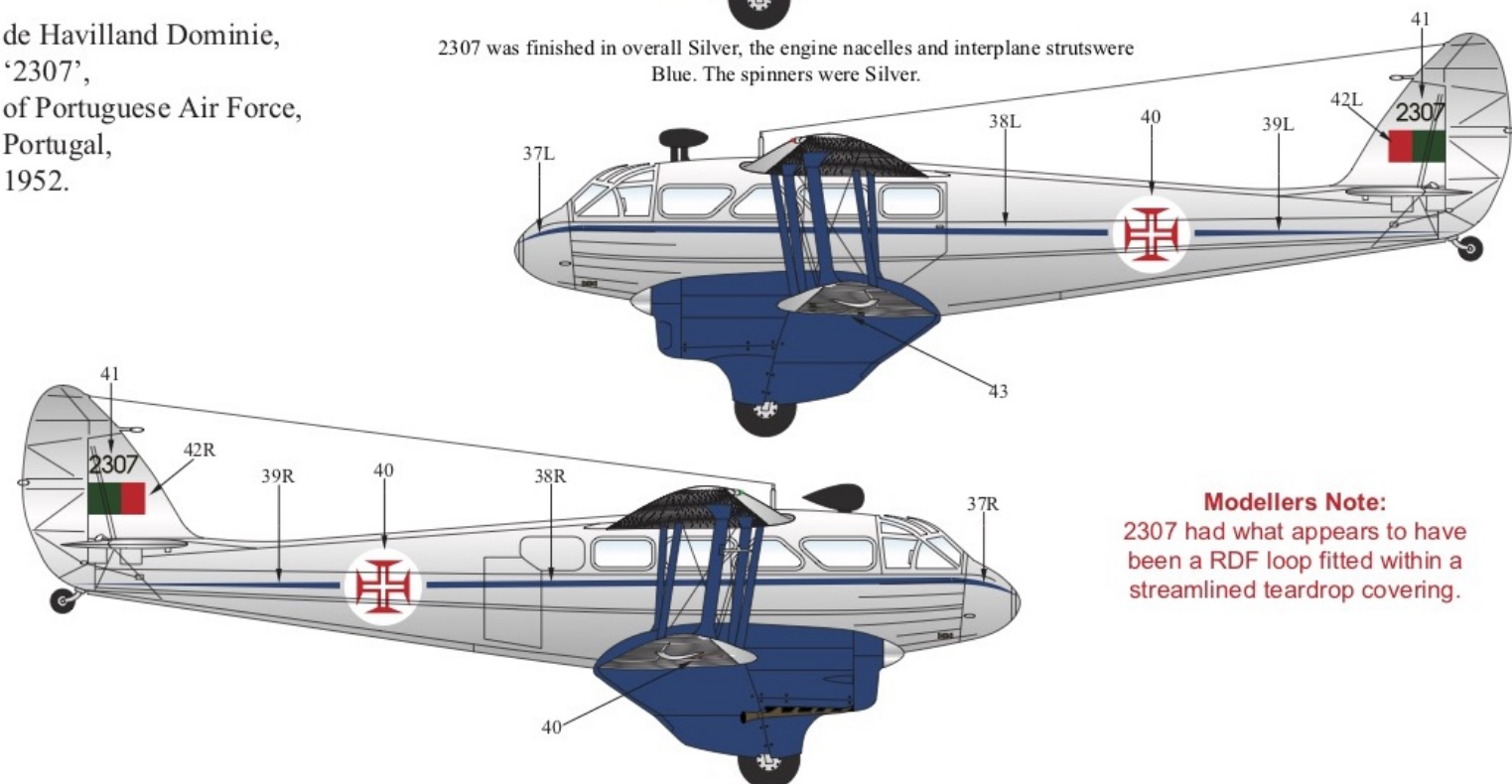

Modellers Note:
 2307 had what appears to have
 been a RDF loop fitted within a
 streamlined teardrop covering.

X7524 was finished in Olive Drab over Neutral Grey undersides. The spinners were White.

de Havilland Dominie,
 X7524,
 of 27th Air Transport Group,
 Eighth Air Force,
 United States Army Air Corps,
 based at Abbots Ripton,
 UK, 1943.

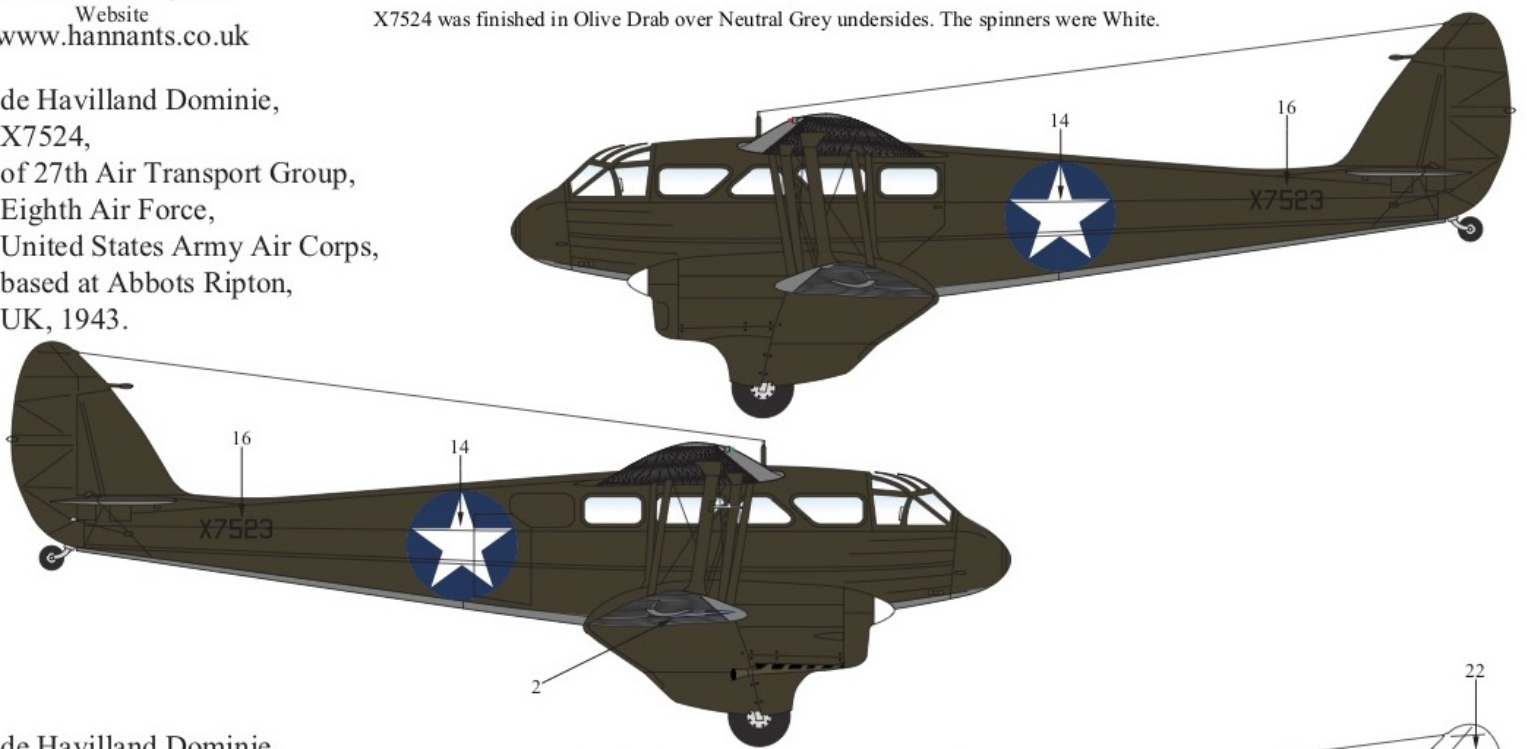

de Havilland Dominie,
 X7394,
 of 782 Naval Air Squadron,
 Royal Navy,
 based at RNAS Donibristle,
 UK,
 1946.

X7394 was finished in overall White, as were the spinners.

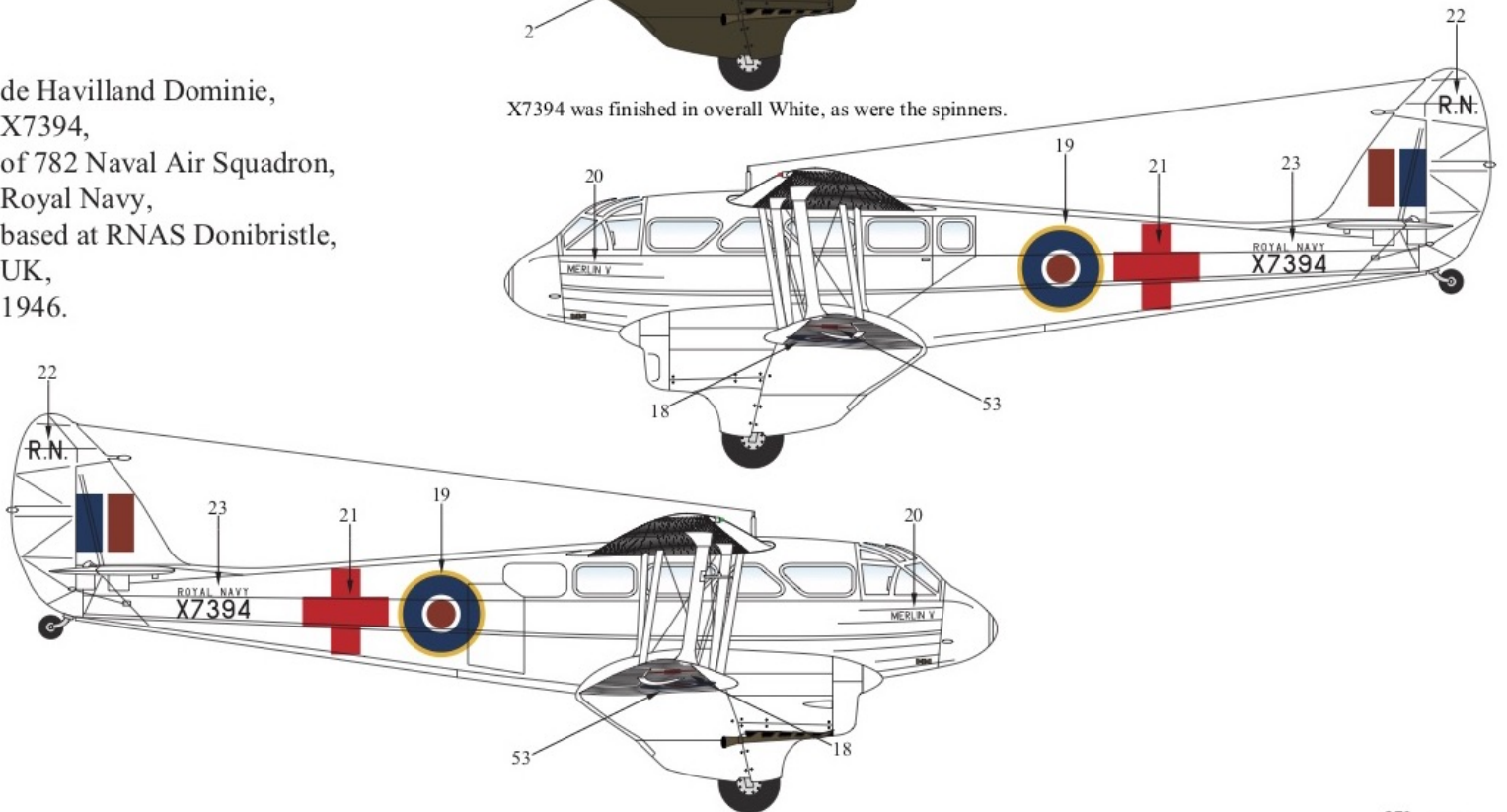

D2 was finished in overall Silver, as were the spinners.

de Havilland Dominie,
 'D2',
 of 367e Escadrille, 169 Wing,
 Belgian Air Force,
 based at Evere,
 Belgium,
 1957.

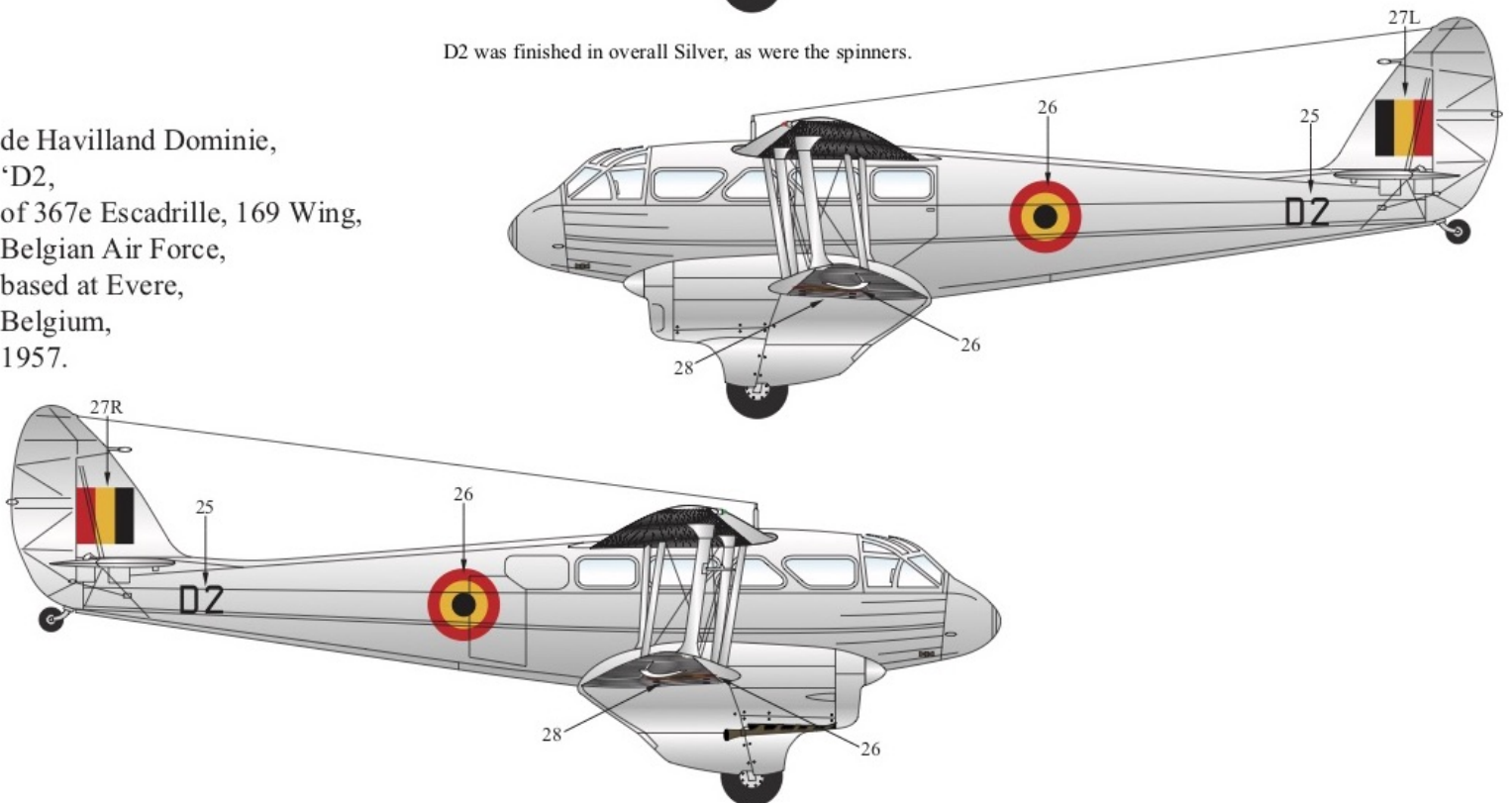

X7524 was finished in Matt Dark Earth and Matt Middle Stone disruptive camouflage over Silver undersides. The lowerwing uppersurfaces had a shadow shaded disruptive camouflage pattern of Light Earth and Light Stone applied, the engine nacelles were Night and the spinners were Natural Metal.

de Havilland Dominie,
 X7524,
 of Misr Airwork,
 based in Egypt,
 1943.

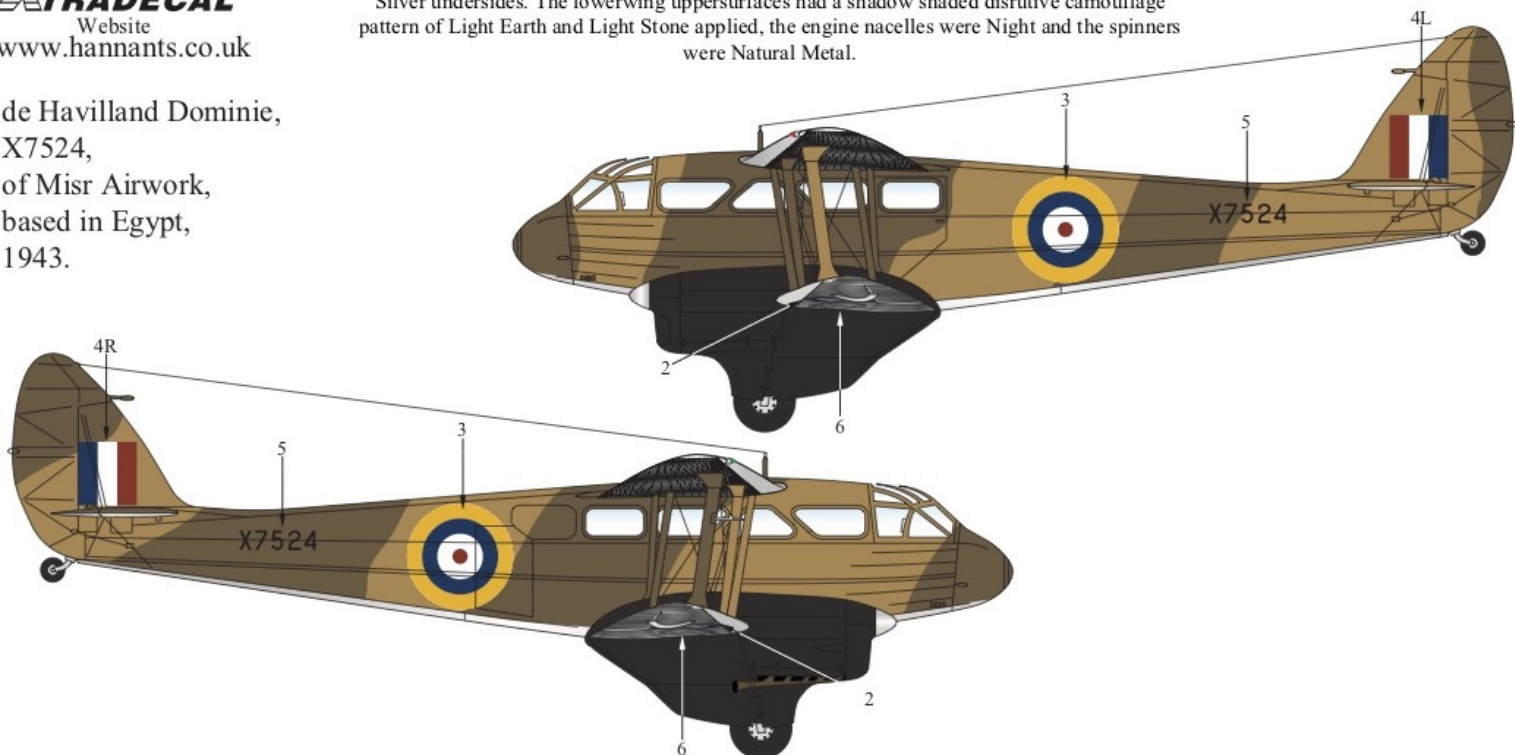

A33-3 was finished in a Matt Earth Brown and Matt Foliage Green disruptive camouflage over Sky Blue undersides. The engine nacelles were Sky Blue along with the spinners.

de Havilland Dominie,
 A33-3,
 of No.1 Air Observers School,
 Royal Australian Air Force,
 based at Cootamundra,
 New South Wales,
 Australia,
 1943.

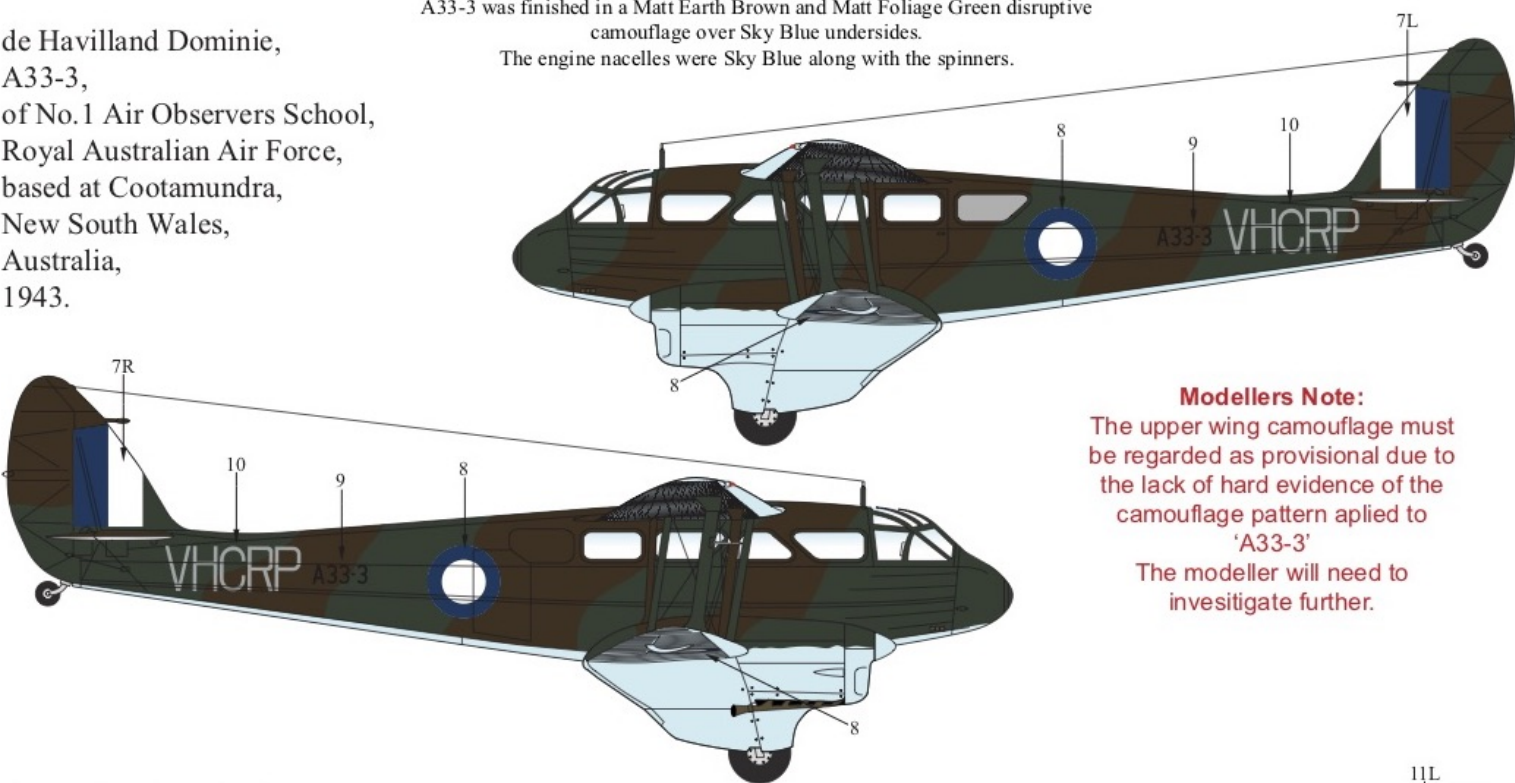

Modellers Note:
 The upper wing camouflage must be regarded as provisional due to the lack of hard evidence of the camouflage pattern applied to 'A33-3'.
 The modeller will need to investigate further.

de Havilland Dominie C.1,
 NZ523,
 of Fiji Communications Flight,
 Royal New Zealand Air Force,
 based in Fiji,
 1944-45.

NZ523 was finished in overall Silver with the spinners being Night.

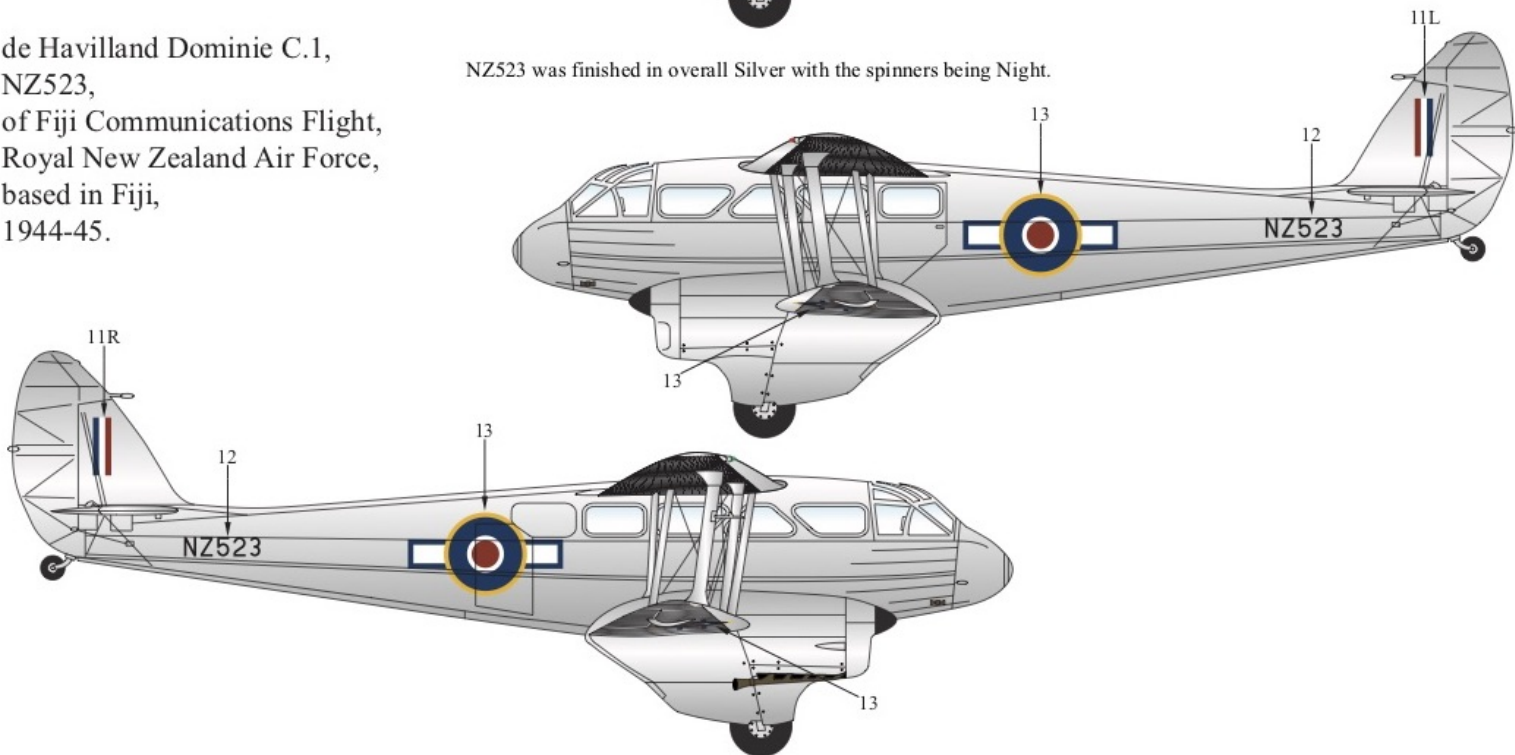

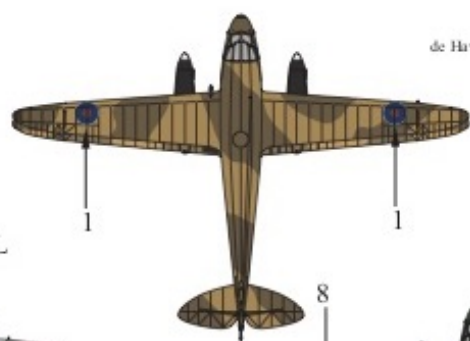

de Havilland Dominie,
X7524.

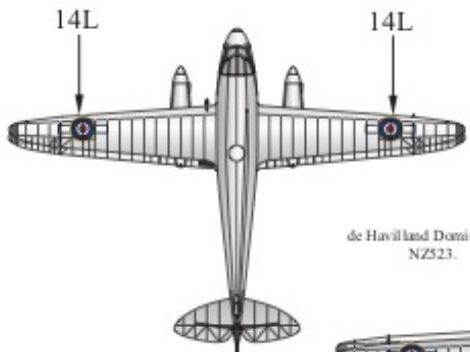
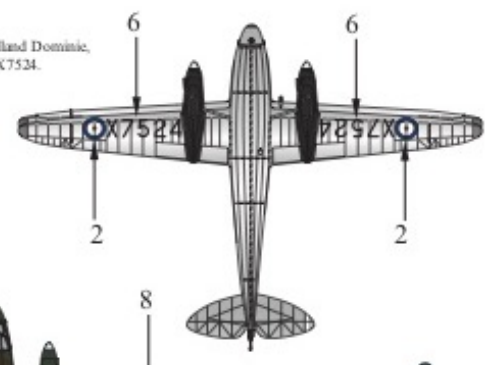

de Havilland Dominie C.1,
NZ523.

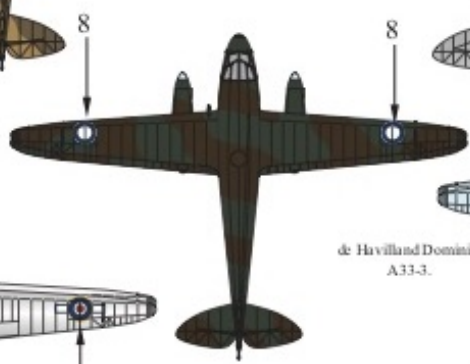

de Havilland Dominie,
A33-3.

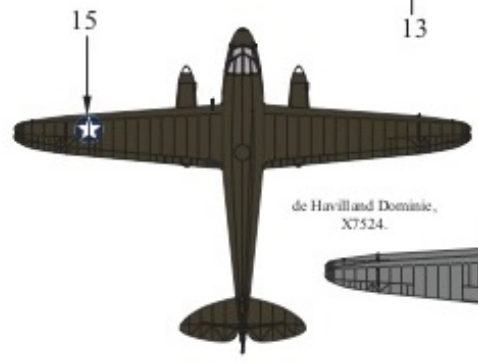
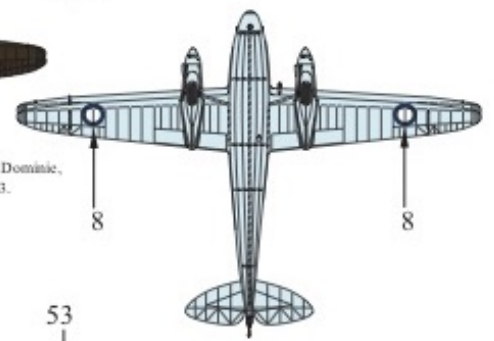

de Havilland Dominie,
X7524.

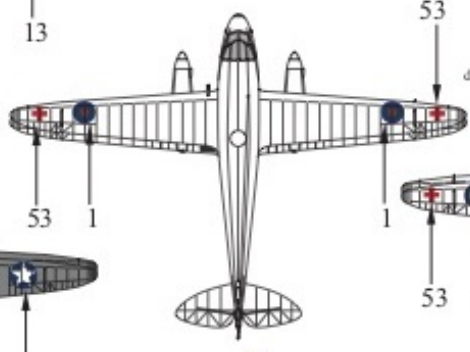
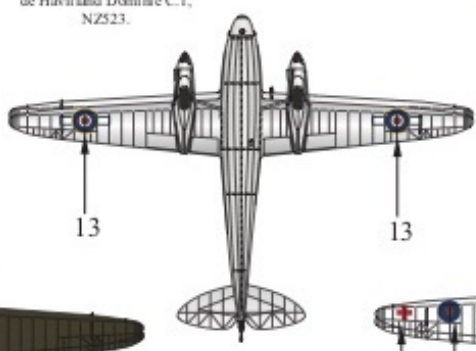

de Havilland Dominie,
X7394.

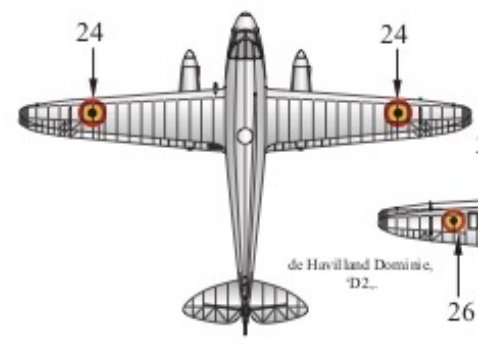
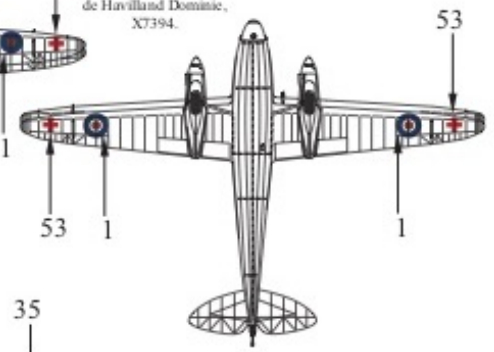

de Havilland Dominie,
'D2'.

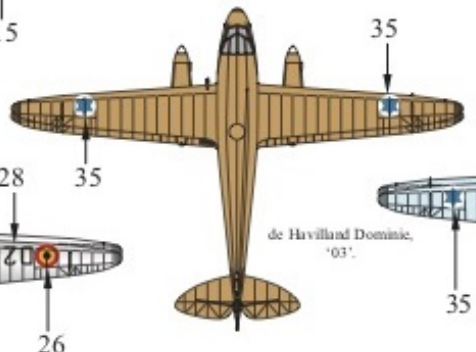
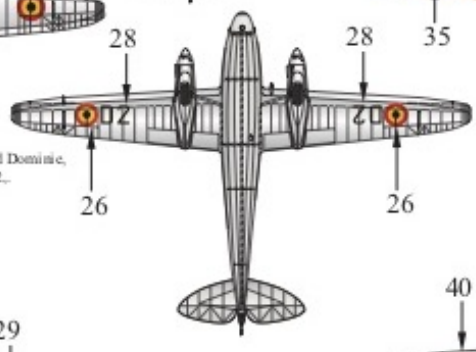

de Havilland Dominie,
'03'.

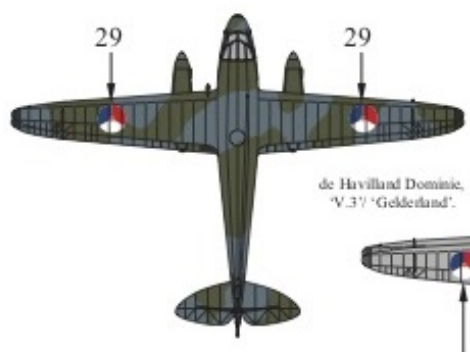
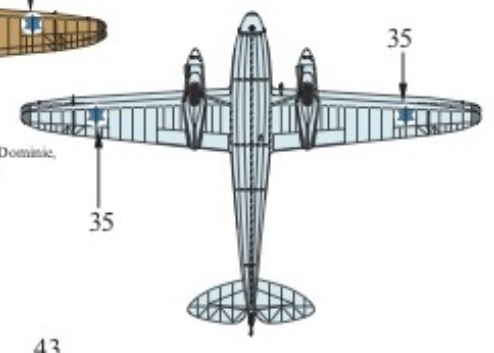

de Havilland Dominie,
'V.3' 'Gelderland'.

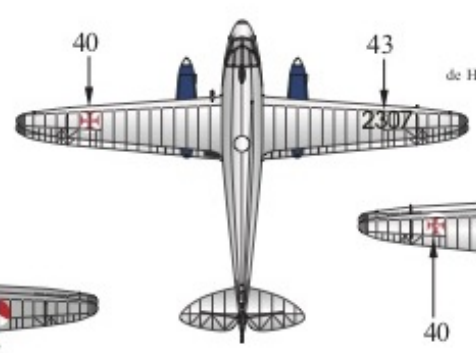
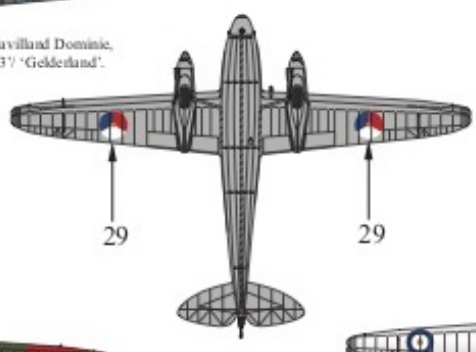

de Havilland Dominie,
'2307'.

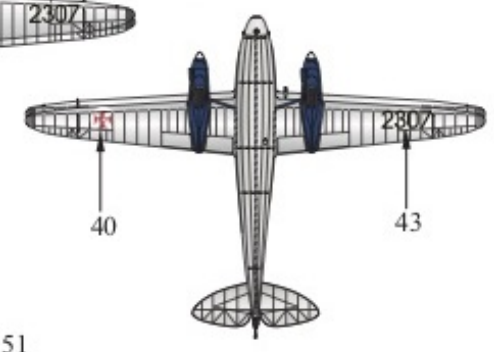

de Havilland Rapide (Military),
6311/2'.

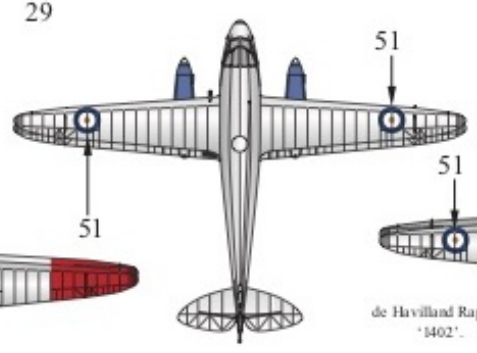

de Havilland Rapide,
'1402'.

