

SOVIET WW II FIGHTER 1:48 SCALE PLASTIC KIT



eduard

INTRO.....

One of the most popular and best known Russian aircraft ever built was born in 1933. On the last day of that year, on December 31, the famous Soviet aviator Valerij Chcalov conducted the maiden flight of the new CKB-12 prototype. The CKB-12 was a very modern and revolutionary design at the time. The installed powerplant was a Shvetsov M-22 engine (a license built Bristol Jupiter) rated at 480 hp, instead of the anticipated Shvetsov M-25 engine giving 750 hp. That was a Soviet license built Wright 1820 Cyclone. Although the new aircraft was a bit underpowered, Chcalov was amazed with its flight capabilities and especially its sensitivity of control. The second prototype was outfitted with an imported original Wright Cyclone engine, and the aircraft performance greatly improved. After necessary development and improvements, serial production was ordered at Zavod 39 in Moscow and at Zavod 21 in Gorki under the VVS (Soviet Air Force) designation I-16. These aircraft were equipped with the M-22 engine, because the new M-25 powerplant was not yet available, and no weapons were installed. Maximum speed of these first I-16s was 362 km/h at sea level and 346 km/h at 3000 m. Fifty aircraft were manufactured at Zavod 39, known as I-16 without any additional suffix designation. Zavod 21 produced the first batch of I-16, though with some difficulties, because three other aircraft types were on their production lines. For this reason, Zavod 21's I-16 were suffixed as „Type 4“. In late summer, 1934, the first aircraft reached VVS units. Reception of the new aircraft was cool, to put it gently. The flight characteristics were very different from the operational biplanes then in service; control was overly sensitive, and the landing speed too high with a lack of frontal view due to the wide nose. The lack of landing flaps, compensated for by the downward deflection of the ailerons acting as flaps on landing, didn't made the landing any easier. Accident rates soared to unacceptable levels, and reached the point where units couldn't achieve operational status. At this time, five NII VVS (Air force research institute) pilots, Kokkinaki, Suprun, Preman, Evseev and Shevchenko, made a tour of air force bases. With their red painted I-16, they demonstrated the aircraft's performance and potential. At about the same time, in late Spring, 1935, M-25 engine was finally available in sufficient quantities, and the development of the I-16 with its originally planned engine, was finally completed. The new engine received a new Watter type cowling, giving the I-16 its characteristic shape. The flight characteristics were unchanged, but the performance significantly improved. The maximum speed was now 390 km/h at sea level, and 445 km/h at 3 000m. The aircraft was now armed with two 7,62 mm ShKAS machine guns mounted in the wings. By January 1936, the Type 5 replaced the Type 4 on the production lines at Zavod 21, and in late spring entered service with VVS units. Still a fresh newcomer on the fighter scene, the I-16 Type 5 soon got the chance to show their stuff in a real fight. Two flights of I-16s were dispatched to Spain to help the Republican forces. During the Spanish Civil War, the I-16 built its great warrior reputation, named Mosca by Republican pilots, but it was their opponent's nickname that became better known, giving the I-16 the best known identifier - the „Rata“. Until 1938, the Type 5 remained as the main version, marginally updated to the Type 6, but it is not certain if this was an official designation. Besides Spain, the Type 5 saw combat over China, where these aircraft were sent along with Soviet crews. By 1937, initial troubles were forgotten, but new critics were found. Problems with poor quality of the perplex canopy nagged on, and two machine guns became insufficient, especially in combat with modern bombers. Therefore, the new and improved Type 10 was introduced, instigating some significant changes. First, the new M-25V 750 hp engine was installed. The wing was re-designed to include landing flaps. Two 7,62 mm ShKAS machine guns were added on top of the engine, with two corresponding fairings on the engine cowling. The cockpit was improved, and the canopy was completely redesigned, with an all-glass single piece windscreen ahead of a now open cockpit. The Aldus OP-1 telescopic gun sight was replaced with new reflector type, the PAK-1. The wing was later modified to provide for retractable landing skis. Maximum speed was 390 km/h at sea level and 438 km/h at 3200 m. The Type 10's production started at Gorki in March, 1938. The Type 10 reached Spain as well as China, and fought against the Japanese over Chalkin-Gol and Chasan Lake. They saw action in the Winter War against the Finns, and also fought in Poland in the Autumn of 1939. In June, 1941, when the USSR was attacked by Germany and the Great Patriotic began, the I-16 Type 10 remained, along with other I-16 versions, the main weapon of VVS fighter units. The Type 10 formed the basis for the up-gunned Type 17. The wing machine guns were replaced by two 20 mm ShVAK cannon in late 1938, and production was set for October of the same year. Further I-16 development came in the form of new engine installation, when the M-62, rated at 800 hp was mated to the airframe. A new AV-1 propeller was also introduced, which required a new, remarkably wide, spinner. The maximum speed was increased to 411 km/h at sea level and 460 km/h at 3200 m. The next version was the Type 24. A modified M-63 engine of 930 hp was used, the radio was added as standard equipment, and the wing and undercarriage were strengthened as well. Thanks to a higher weight, maximum speed was now at 408 km/h (some sources indicate 440 km/h) and 460 km/h at 4700 m (489 km/h by some sources). The I-16 Type 24 entered service in November, 1939, and became the main production version in 1940. It is believed that most I-16s on the front lines in June, 1941, were Type 24s. The final version was the Type 29, in 1940. To reduce weight, the weapon load was reduced to three machine guns, when the two wing weapons were removed, and a third, in this case the 12,7 mm UBS, was mounted under the engine in the belly of the aircraft. The wing was completely redesigned, increasing the metal plated area to the full bottom surface of the wing. The bomb/external fuel tank racks were installed under the wing, and also rocket rails became standard. It seems that the future I-16 role was expected to be that of fighter-bomber, because new, modern fighters were ordered into service in early 1941. Nevertheless, during the early years of the Great Patriotic War, I-16s of all versions played their part extremely well. In 1942, they remained an important force. The early teething troubles were definitively over, and the I-16 took on the role of the 1934-era biplane fighters. The I-16 became well liked by pilots and crews alike, and were viewed as reliable types. Most I-16s were produced during the pre-war years, and the quality was much higher than of the new fighters, which were hampered by production under wartime conditions. Nevertheless, the time of the I-16 was over by late 1942, the technical and performance superiority of their opponents became too high, and the I-16 withdrawal from frontline service was just a question of time. But, they remained in service even as late as 1943. Although the nomenclature of the I-16 lineage looks as though the types were produced in a chronological order, it was quite different in reality. Production was mixed, and different types were on production lines together. Production of the Type 5 continued even when the Type 24 was being manufactured. In 1941, the types were also mixed within the front line units. Perhaps this is one of the reasons, why there is so much confusion surrounding the subtyping of the I-16. In total some 9450 I-16s of all versions were produced, most of them, to the tune of 8495, by Zavod 21 at Gorki.

TECHNICAL SPECIFICATIONS:

Engine: M-25V 750 hp
 Empty weight: 1428 kg
 Loaded weight: 1814 kg
 Maximum speed
 at sea level: 385 km/h
 at altitude: 426 km/h at 2500 m
 Initial climb: 549 m/min
 Time to height: 9,0 min to 5000 m
 Service ceiling: 8250 m
 Armament: 2x ShKAS 7,62mm
 2x ShVAK 20 mm

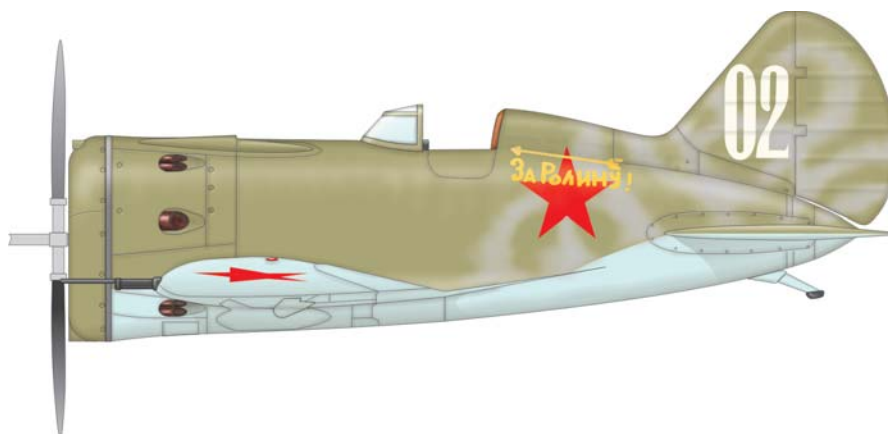

- (GB)** Carefully read instruction sheet before assembling. When you use glue or paint, do not use near open flame and use in well ventilated room. Keep out of reach of small children. Children must not be allowed to suck any part, or pull vinyl bag over the head.
- (CZ)** Před započatím stavby si pečlivě prostudujte stavební návod. Při používání barev a lepidel pracujte v dobře větrané místnosti. Lepidla ani barvy nepoužívejte v blízkosti otevřeného ohně. Model není určen malým dětem, mohlo by dojít k požití drobných dílů.
- (F)** Lire soigneusement la fiche d'instructions avant d'assembler. Ne pas utiliser de colle ou de peinture à proximité d'une flamme nue, et aérer la pièce de temps en temps. Garder hors de portée des enfants en bas âge. Ne pas laisser les enfants mettre en bouche ou sucer les pièces, ou passer un sachet vinyl sur la tête.
- (D)** Von dem Zusammensetzen die Bauanleitung gut durchlesen. Kleber und Farbe nicht nahe von offenem Feuer verwenden und das Fenster von Zeit zu Zeit Belüftung öffnen. Bausatz von kleinen Kindern fernhalten. Verhüten Sie, daß Kinder irgendwelche Bauteile in den Mund nehmen oder Plastiktüten über den Kopf ziehen.
- (JP)** 組み立てる前に必ず説明書をお読み下さい。接着剤や塗料をご使用の際は、窓を開けて十分な換気をおこない、火のそばでは使用しないで下さい。小さな子供の手の届かない所に必ず保管してください。部品や破片を噛んだり、なめたり、飲んだりすると大変危険です。又、部品を取り出した後のビニール袋は、小さな子供が頭から被ったりすると窒息する恐れがありますので、破り捨てして下さい。

INSTRUCTION SIGNS * INSTR. SYMBOL * INSTRUKTION SINNBILDEN * SYMBOLES * 記号の説明

- | | | | | | | |
|--|--|--|--|--|---|--|
| | | | | | | |
| OPTIONAL
VOLBA
FACULTATIF
NACH BELIEBEN
選択する | BEND
OHNOUT
PLIER SIL VOUS PLAIT
BITTE BIEGEN
折る | OPEN HOLE
VYVRTAT OTVOR
FAIRE UN TROU
OFFNEN
穴を開ける | SYMMETRICAL ASSEMBLY
SYMETRICKÁ MONTÁŽ
MONTAGE SYMÉTRIQUE
SYMMETRISCHE AUFBAU
左右均等に組み立てる | NOTCH
ZÁŘEZ
L'INCISION
DER EINSCHNITT
切る | REMOVE
ODŘÍZNOUT
RETIRER
ENTFERNEN
移す | APPLY EXPRESS MASK
AND PAINT
POUŽIT EXPRESS MASK
NABARVIT |

PARTS * DÍLY * TEILE * PIÈCES * 部品

PLASTIC PARTS

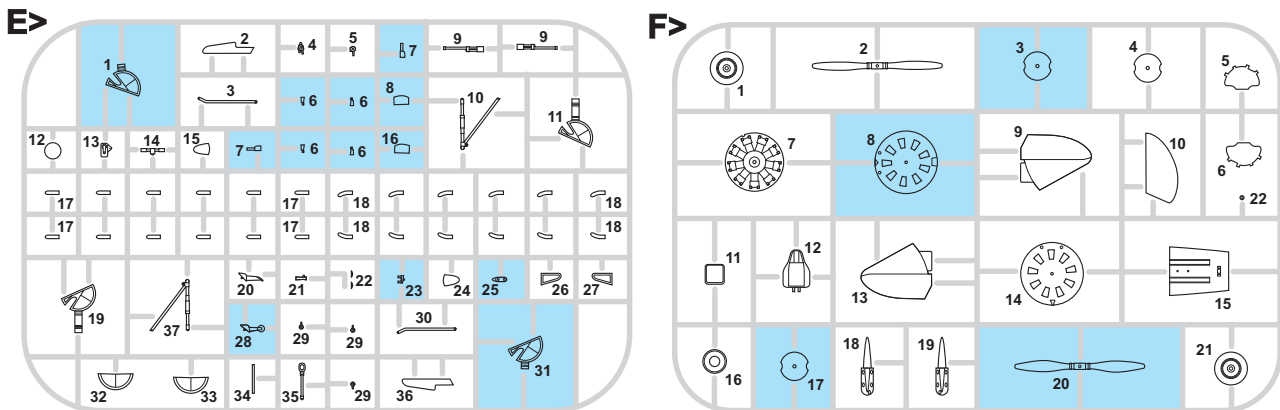
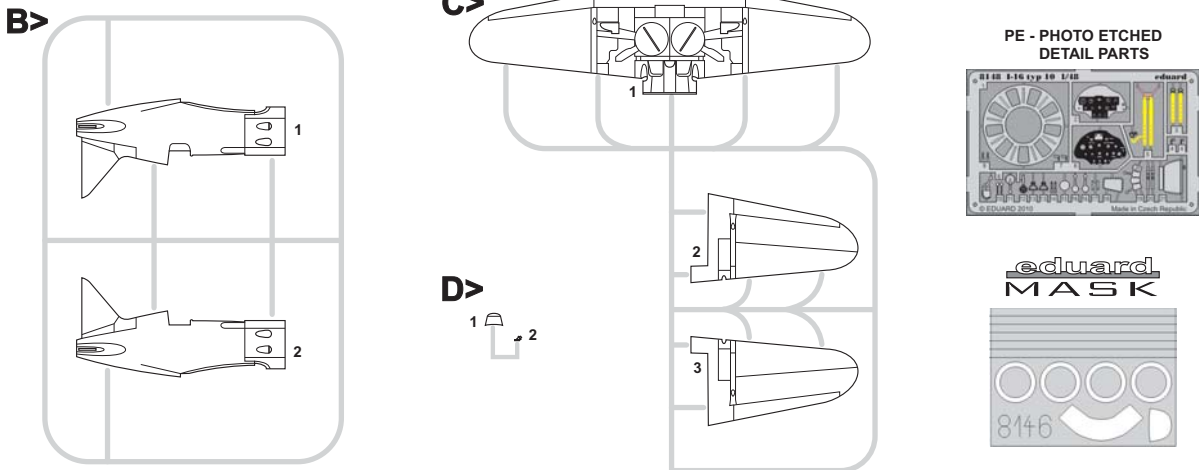

-Parts not for use. -Teile werden nicht verwendet. -Pièces à ne pas utiliser. -Tyto díly nepoužívejte při stavbě. -使用しない部品

COLOURS * BARVY * FARBEN * PEINTURE * 色

GSI Creos (GUNZE)		
AQUEOUS	Mr.COLOR	
[H 4]	[4]	YELLOW
[H 11]	[62]	FLAT WHITE
[H 12]	[33]	FLAT BLACK
[H 47]	[41]	RED BROWN
[H 52]	[38]	OLIVE DRAB
[H 57]	[73]	GRAY
[H 61]	[35]	LIGHT GRAY
[H 67]	[115]	LIGHT BLUE
[H 77]	[]	TIRE BLACK
[H 90]	[47]	CLEAR RED

AQUEOUS	Mr.COLOR	
[H 94]	[]	CLEAR GREEN
[H 303]	[303]	GREEN
[H 344]	[]	RUST
[]	[74]	LIGH BLUE
[]	[136]	GREEN
Mr.METAL COLOR		
[MC214]	[]	DARK IRON
[MC218]	[]	ALUMINIUM
Mr.COLOR SUPER METALLIC		
[SM06]	[]	CHROME SILVER

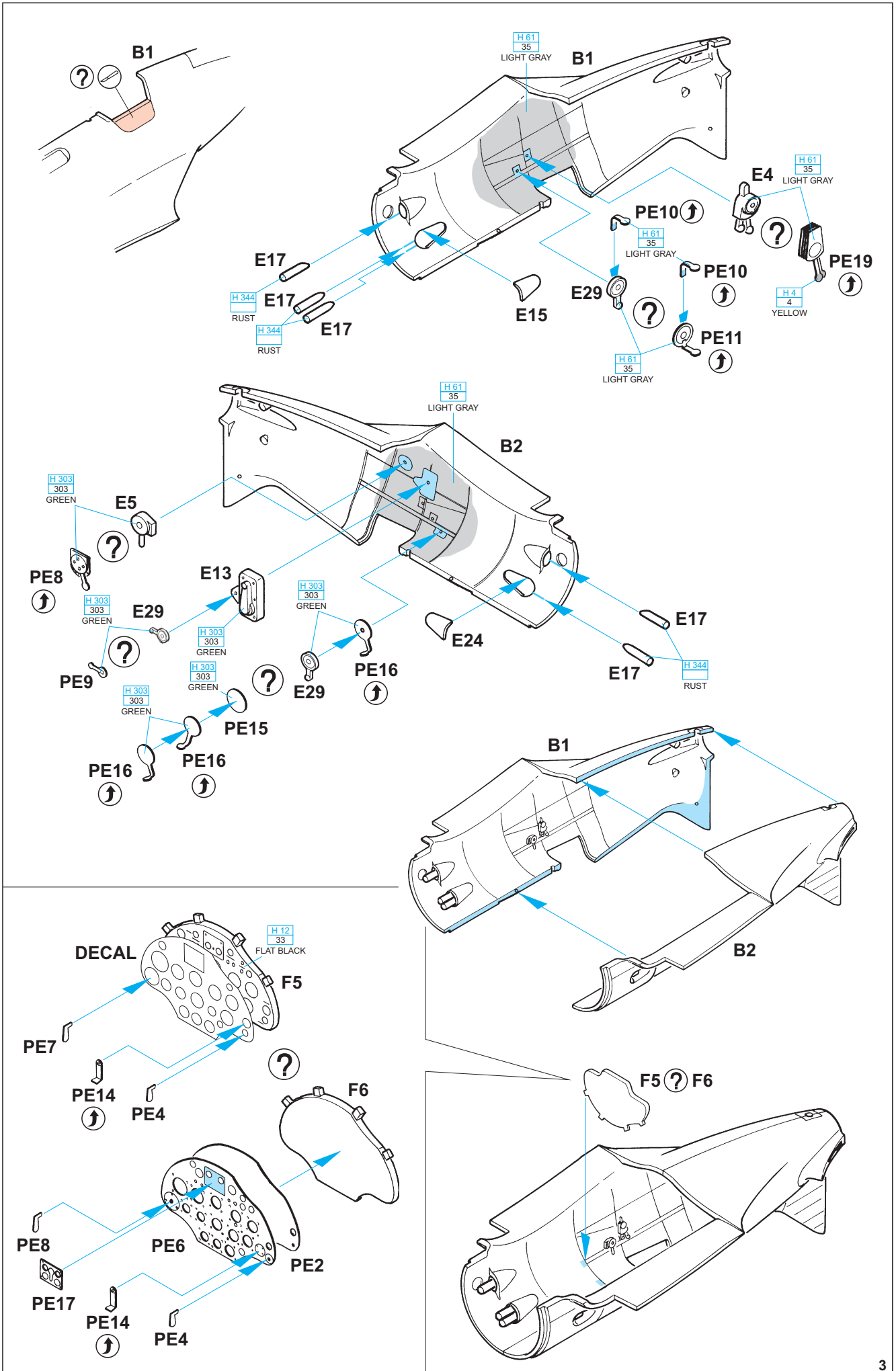

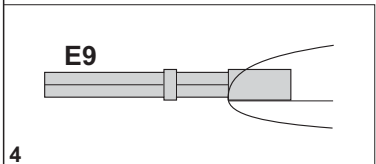
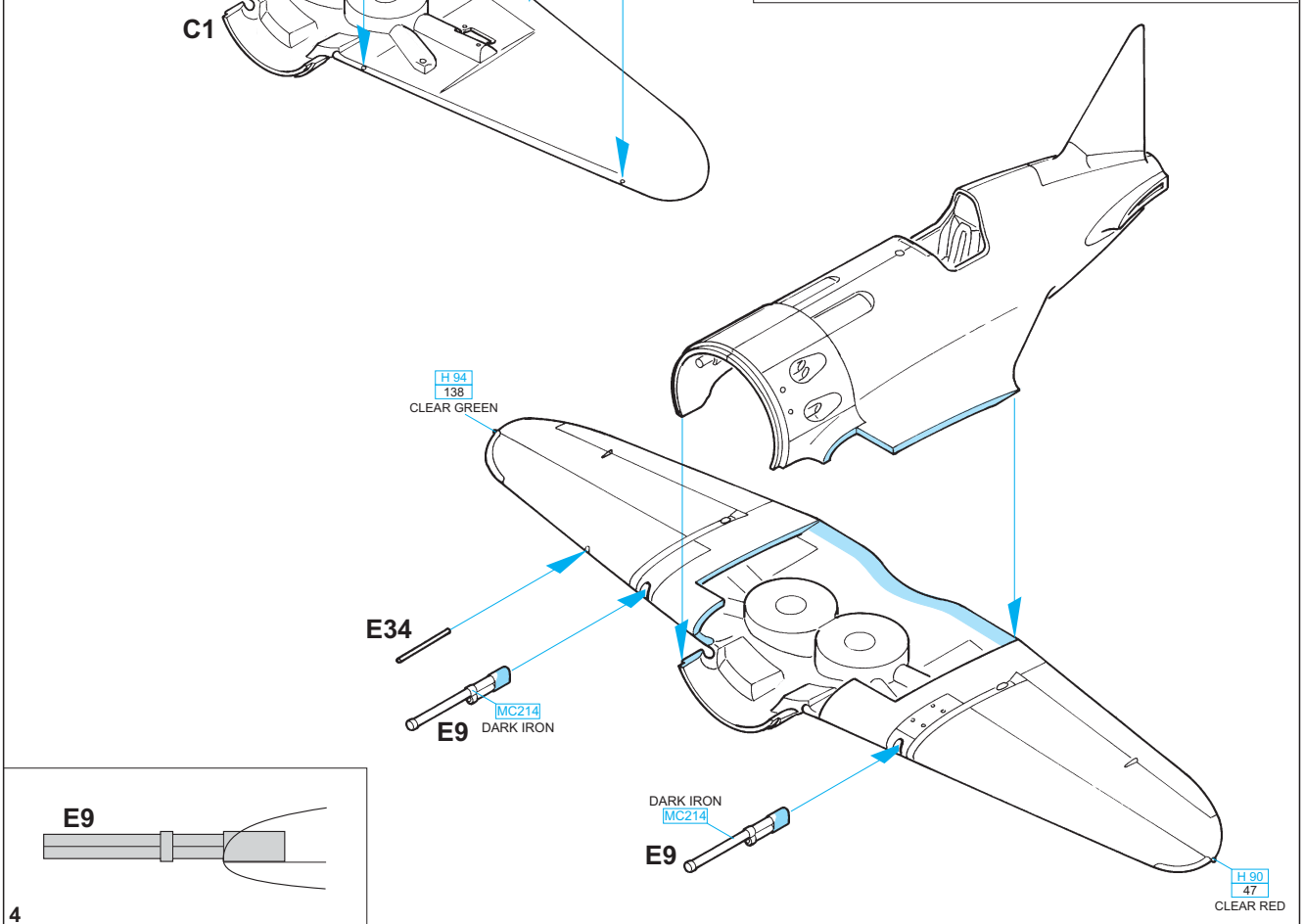
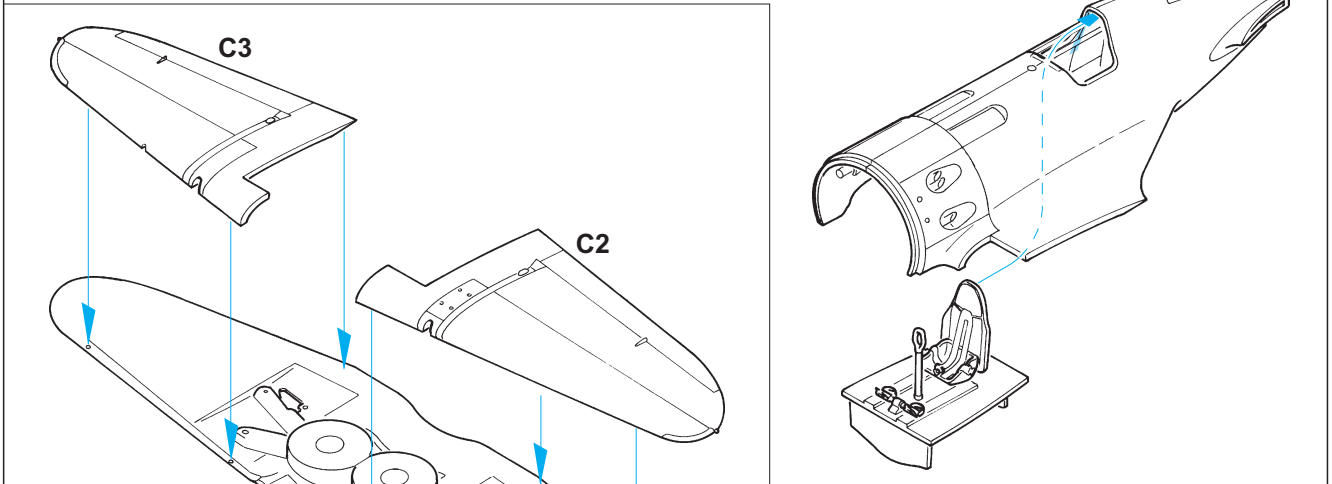
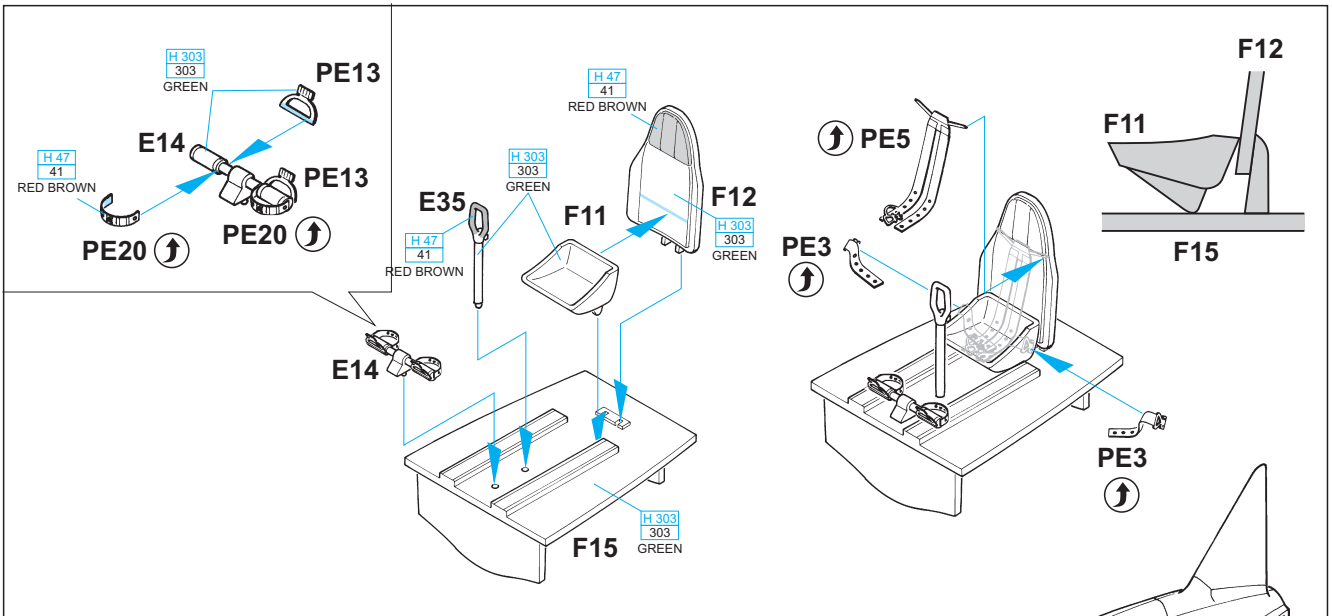

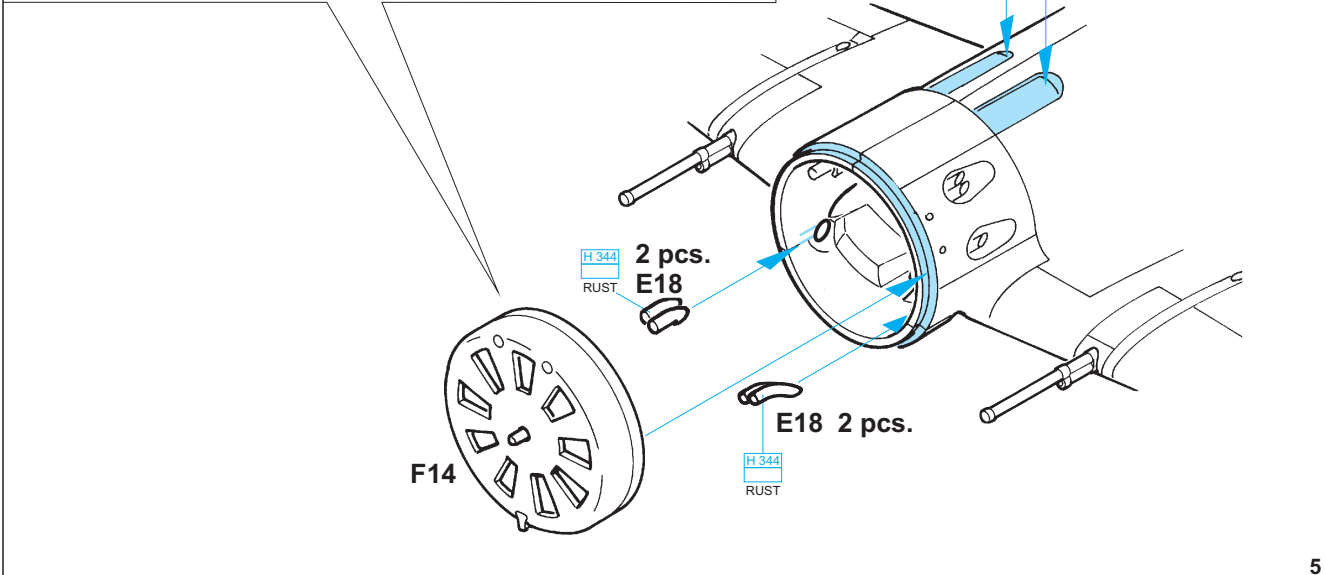
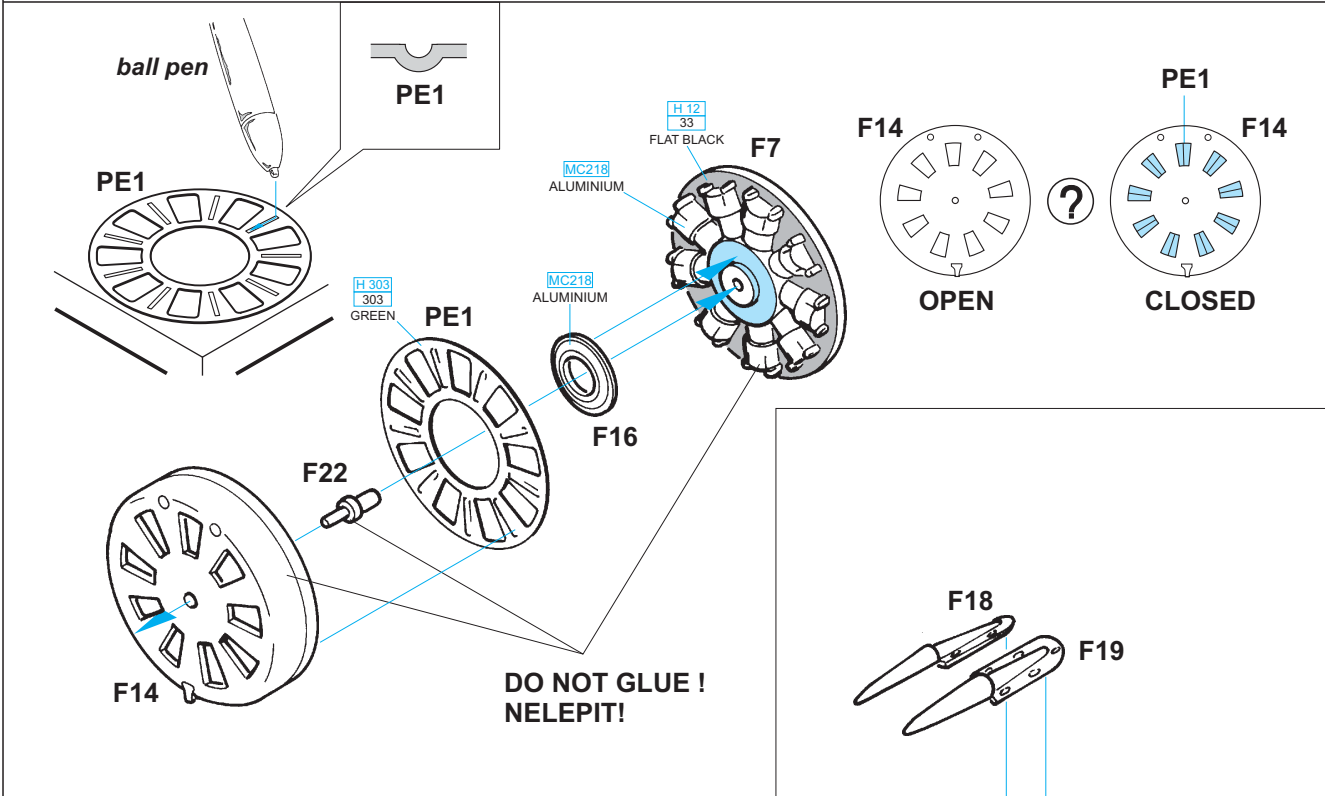
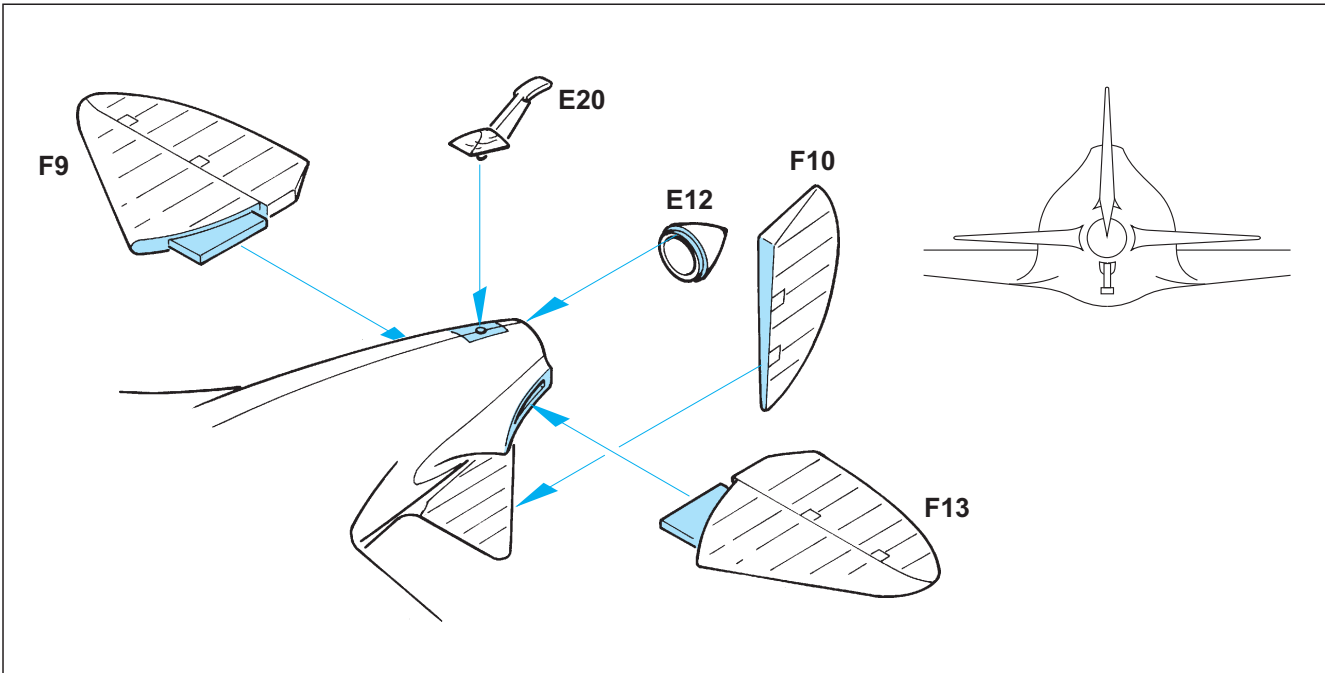

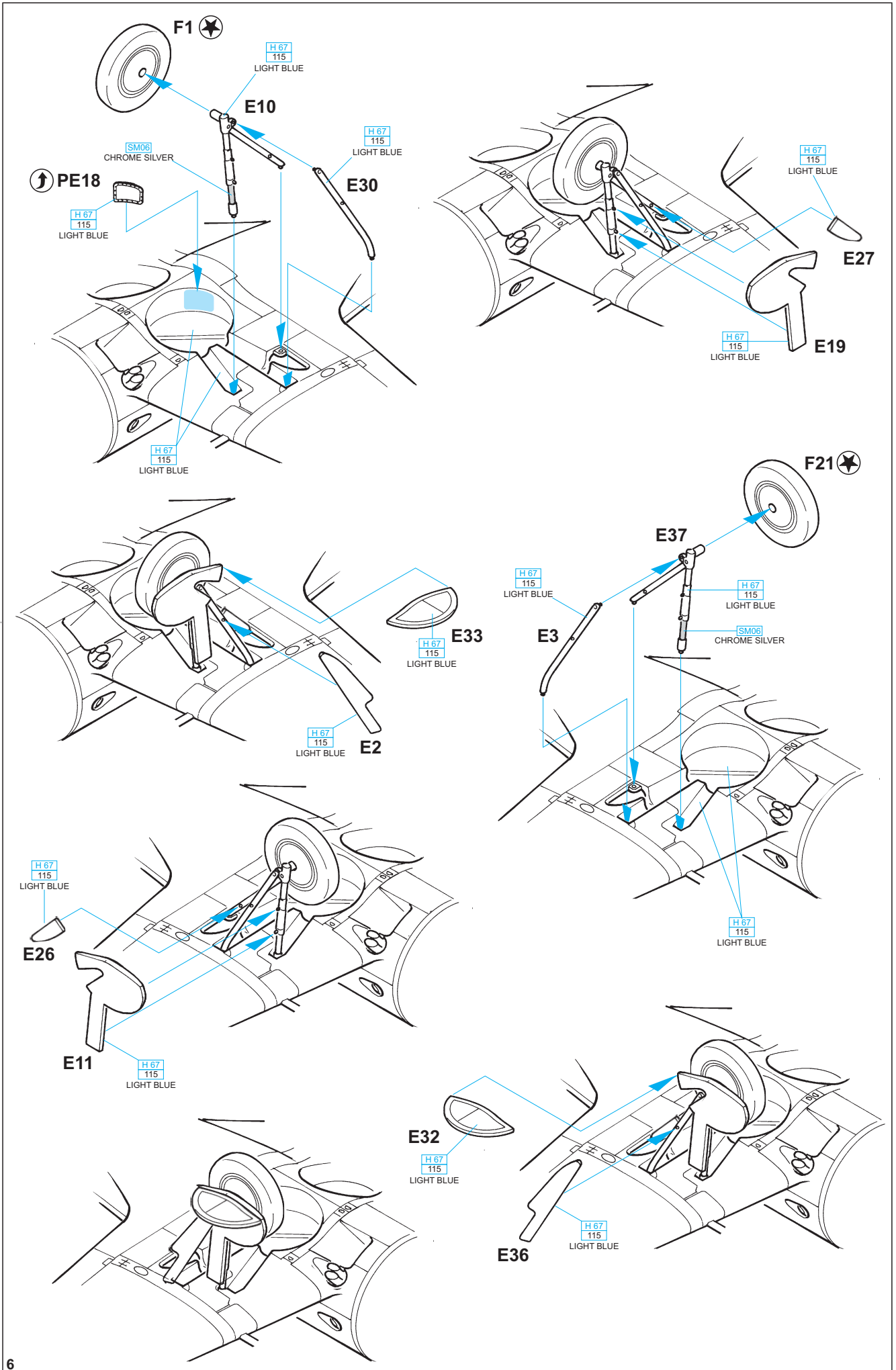

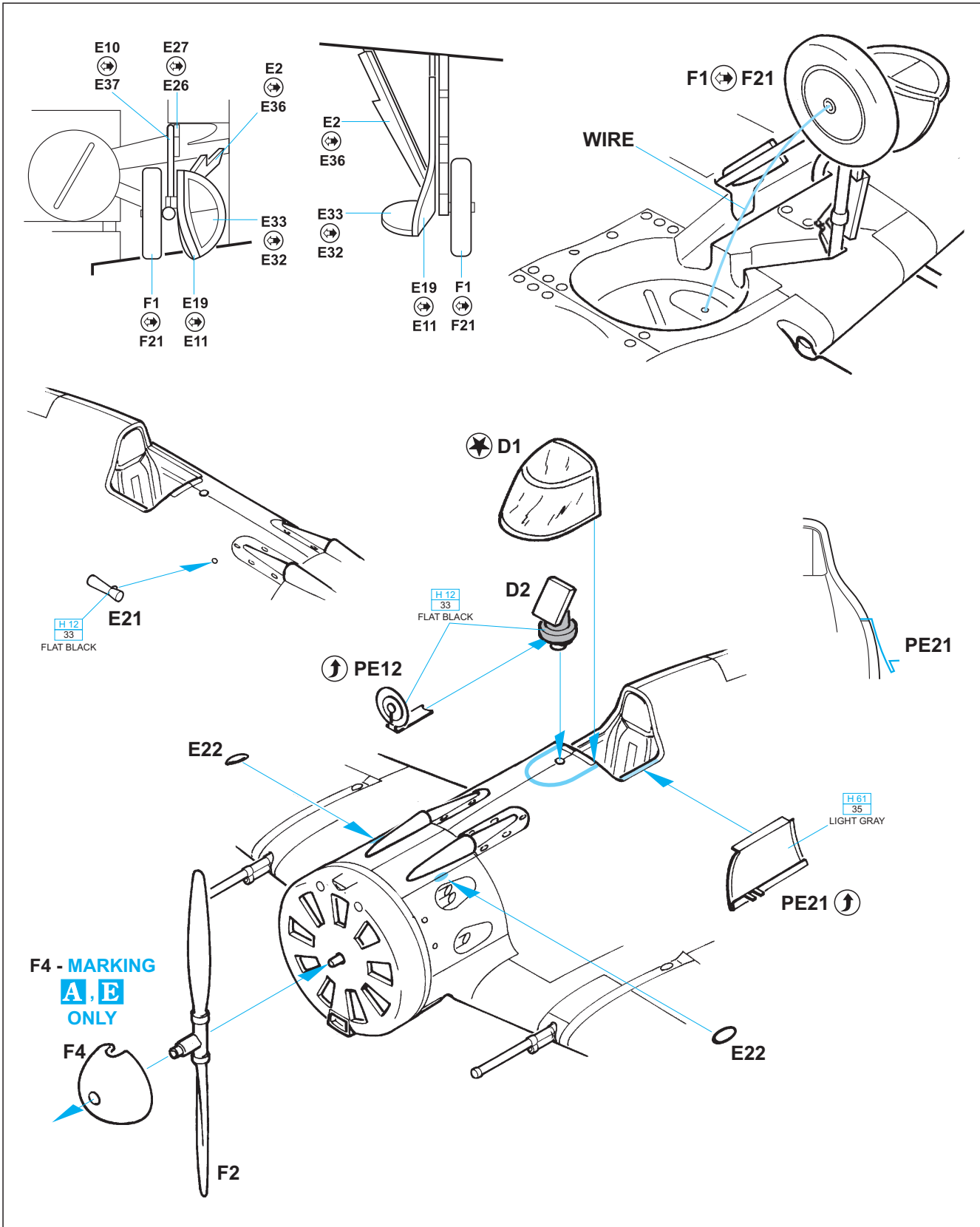

eduard
MASK

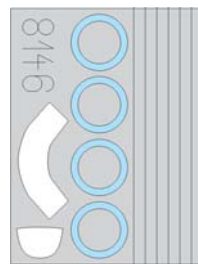
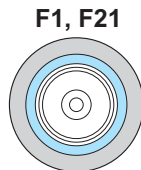
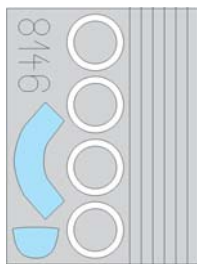
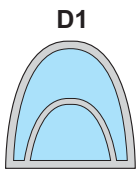

A I-16 Type 17, 22nd IAP, 2nd Lt. Katalov, summer 1939, Nomonhan, Mongolia

The 22nd IAP was despatched to the Nomonham plains in late May 1939. It was equipped with I-16s delivered directly from the manufacturing plant. These aircraft wore the original camouflage of overall Light-Grey paint. This camouflage scheme was very similar to the Japanese one and the similarity led to many fatal misunderstandings during aerial fights. This is the reason why the unit HQ asked for repainting of uppersurfaces in Green. Only the Light-Grey fuselage band was left during this process and I-16s used by 22nd IAP are easily recognizable thanks to this band. The I-16 No. 51 was flown by 2nd Lt. Katalov who crashlanded her during the combat deployment in Nomonhan.

22. IAP se na nomonhanské pláně dostal na konci května 1939. Jeho I-16 byly přímo od výrobce kamuflvány světle šedou barvou na všech plochách. To ovšem vedlo k několika tragickým omylům v bojích, protože velmi podobnou kamufláž nesly také japonské stíhačky. Proto štáb 22. IAP požádal o kamuflování horních ploch zelenou barvou. Ta byla nanesena tak, že na zadní části trupu byl ponechán pruh původní světlé barvy, a stala se identifikačním znakem jednotky. S tímto strojem havaroval na polním letišti mladší lejtěnant Katalov.

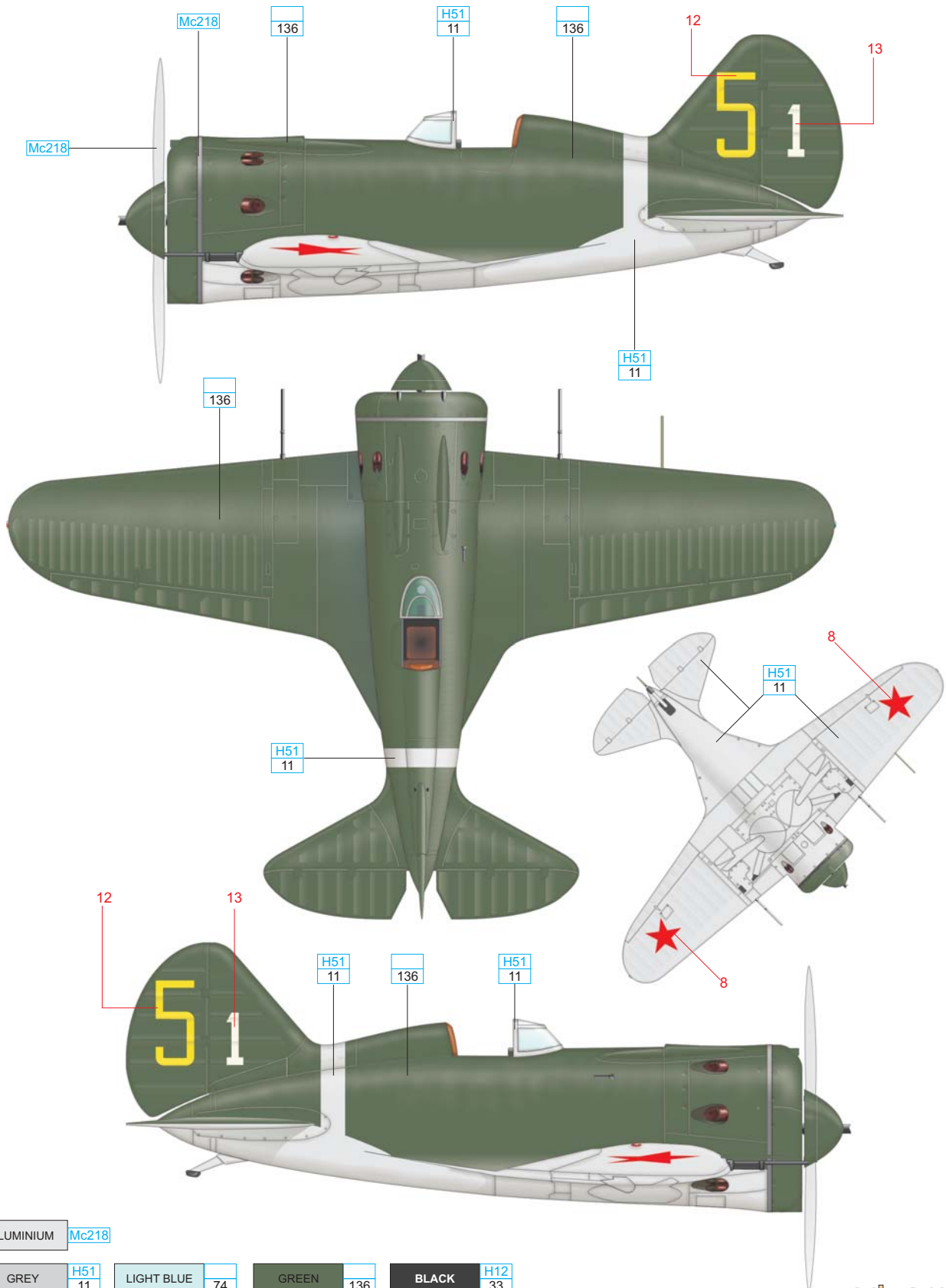

B I-16 Type 17, Leningrad Area, Summer 1941

This I-16 Type 17 was photographed in summer 1941 near Leningrad. Big white numbers appeared on the fuselage sides of fighter airplanes shortly after the war outbreak. The exact user of this I-16 remains unknown.

Tento I-16 Typ 17 byl vyfotografován v létě 1941 v okolí Leningradu. Velká bílá čísla se na bocích stíhacích letounů objevila krátce po začátku bojů na východní frontě. Konkrétní jednotka, která používala tento stroj, není známa.

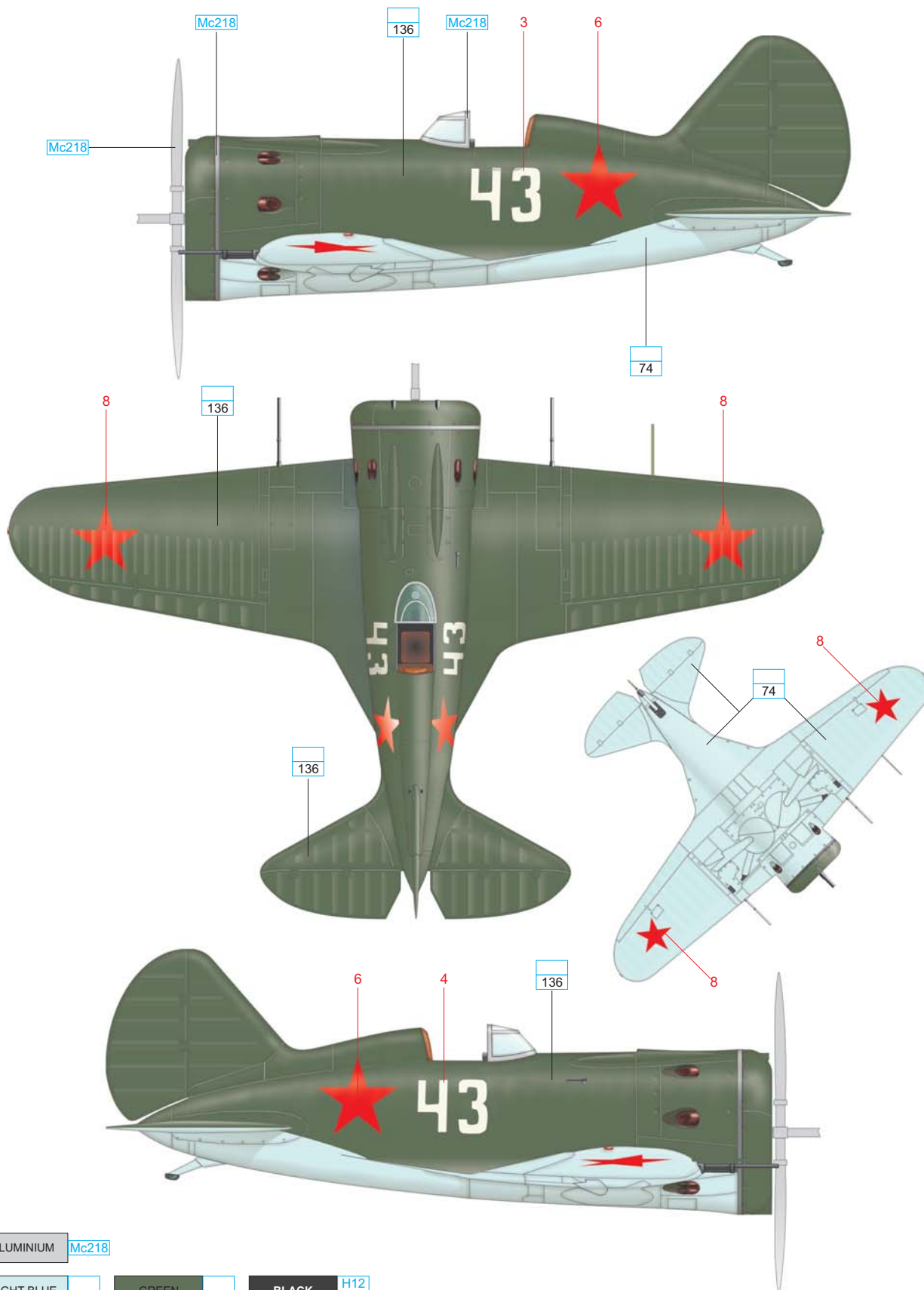

ALUMINIUM Mc218

LIGHT BLUE 74

GREEN 136

BLACK H12
33

C I-16 Type 17, 191st IAP, 1st. Lt. Gennadiy S. Zhuikov, Summer 1941

This mount was flown by 1st Lt. Gennadiy S. Zhuikov, member of 191st IAP (Fighter Air Regiment). We couldn't exclude that it was used by other pilots of this air unit. The airplane wore typical manufacturer camouflage scheme which consists of Green on upper sides and Light Blue on undersides. The fuselage was partially repainted with lighter Green. Note the lack of the spinner. Forward side of propeller blades are camouflaged with dark colour dots, probably Green ones. Front part of cowling seems to be darker than the rest of fuselage on b/w photos and could be painted in Red.

Gennadiy Sergejevitch Zhuikov is credited with 17 victories in total (including 4 shared). At least seven of them he achieved in September 1941 while defending Leningrad city. He survived war and flown following fighters during his WWII career: Polikarpov I-16, Hawker Hurricane, Bell Airacobra and Lavochkin La-5.

Tento stroj patřil na samém počátku ozbrojeného konfliktu mezi Sovětským Svazem a Německem do stavu 191. IAP. Je přisuzován jako osobní stroj nadporučíku G. S. Žujkovovi, ale není vyloučeno, že jej používali i další piloti tohoto stíhacího pluku. Letoun nese standardní tovární schéma zelené barvy na horních plochách a světle modré na spodních plochách. Toto schéma bylo později částečně na trupu přetřeno světlejší zelenou barvou. Letoun postrádá vrtulový kužel. Vrtulové listy jsou na jejich přední straně kamuflvány množstvím malých tmavých, zřejmě zelených skvrn. Čelní část motorového krytu se zdá být na dčb fotkách tmavší a mohla být natřena jinou, zřejmě červenou barvou.

Gennadij Sergejevvič Žujkov dosáhl celkem 17 vítězství, z toho 13 samostatně. Nejméně sedm z nich si připsal během září 1941 při obraně Leningradu. Postupně létal na stíhačkách I-16, Hurricane, Airacobra a La-5, dožil se konce války.

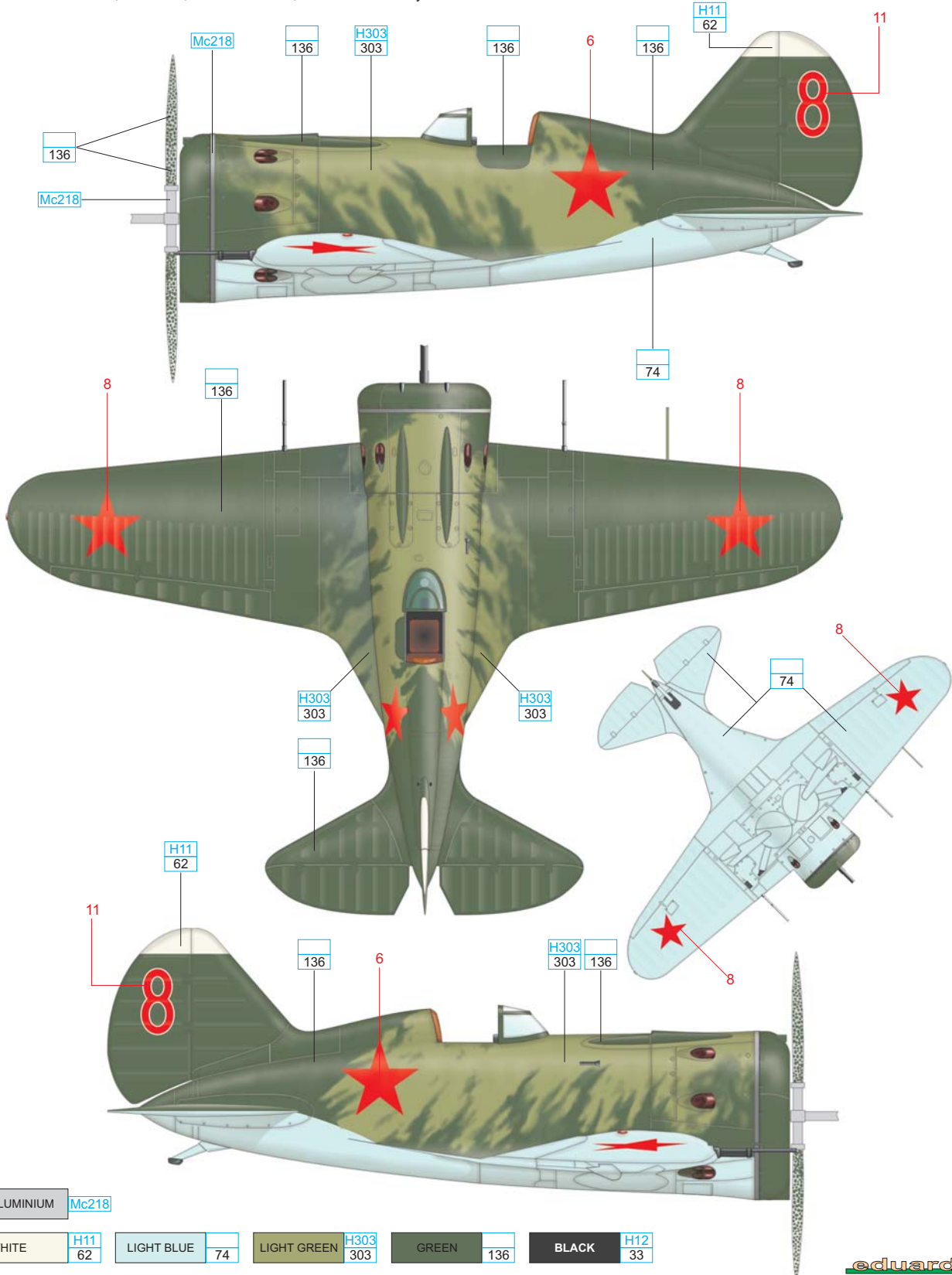

D I-16 Type 17, 84th IAP, Capt. A. A. Khudiakov, Caucasus, Soviet Union, 1942

This I-16 Type 17 wore an interesting camouflage scheme including white or light grey snakelines on the standard green upperside camouflage colour. The light snakelines are seen just on the rear fuselage. It is believed this aircraft was flown by Alexandr Anisimovitch Khudiakov, member of 84th IAP in the South Caucasus area in 1942. He is credited with 10 kills (including 7 shared). The patriotic inscription on the fuselage Red Star means „For the native country”. The pronunciation is „Za rohdinu”.

There were two 84th IAPs in the VVS. The first one was equipped with I-153 Tchaika biplanes and was disbanded in December, 1942. The second one was established later and was renamed 101st GIAP on July 17, 1943. The second one used various versions of I-16 up to 1943.

Tento I-16 Typ 17 je připisován Alexandru Anisimoviči Chudjakovovi, příslušníku 84. IAP. Létal s ním v létě 1942 nad oblastí jižního Kavkazu. Sestřelil celkem 10 nepřátelských letadel, z toho 3 samostatně. Netradičním doplňkem kamuflážního schématu jsou hady světlé barvy (zřejmě bílá nebo světle šedá) nastříkané na zadní části trupu. Nápis v azbuce na levé straně trupu se čte „Za ródinu“ a v překladu znamená „Za vlast”.

Zajímavostí je, že existovaly dvě jednotky nesoucí označení 84. IAP. První byla vyzbrojena typem Polikarpov I-153 Čajka a byl zrušen v prosinci 1942. Druhá jednotka vznikla později a byla 17. července 1943 přeznačena na 101. GIAP (gardový stíhací letecký pluk). Používala různé verze Polikarpovů I-16 až do roku 1943.

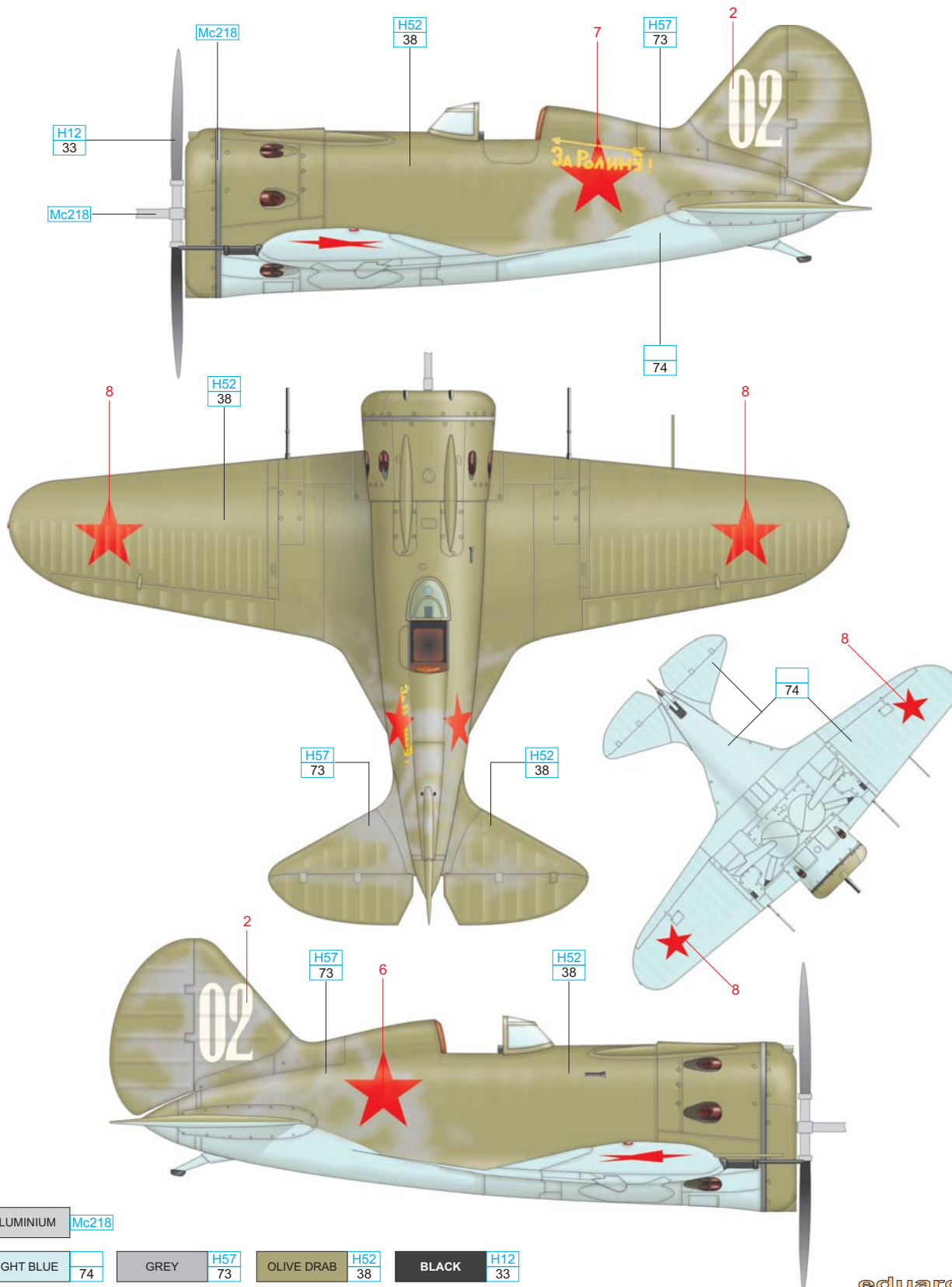

E I-16 Type 17, 4th, GIAP KBF, Mikhail Ya. Vasiliev, Spring 1942

This I-16 Type 17 wore standard 1942/43 two-tone camouflage scheme on uppersides. It is assumed that this aircraft was flown by 2nd Lt. Mikhail Yakovlevitch Vasiliev, a member of 4th GIAP KBF (Guards Fighter Air Regiment of Baltic Fleet) in spring 1942. Vasiliev is credited with 24 victories (4 + 20 shared) and awarded with Hero of Soviet Union title (the higher Soviet distinction) on June 14, 1942 for the bravery and fighting spirit. He was killed in an aerial combat with Fw 190 fighters on May 5, 1943.

Tato I-16 Typ nese standardní kamufláž z let 1942 až 1943. Je tvořena nepravidelnými poli olivově zelené a černé barvy na horních plochách, spodní plochy kryje světlé modrá. Letoun létal v řadách 4. GIAP KBF (gardový stíhací letecký pluk Baltické flotily), jeho pilotem byl dle všeho Michail Jakovlevič Vasiljev, stíhací eso s celkem 24 sestřely na kontě (4 samostatné + 20 ve spolupráci). Za odvahu a hrdinství byl dne 14. června 1942 dekorován vyznamenáním Hrdina Sovětského svazu. Padl 5. května 1943 v boji s německými Fw 190.

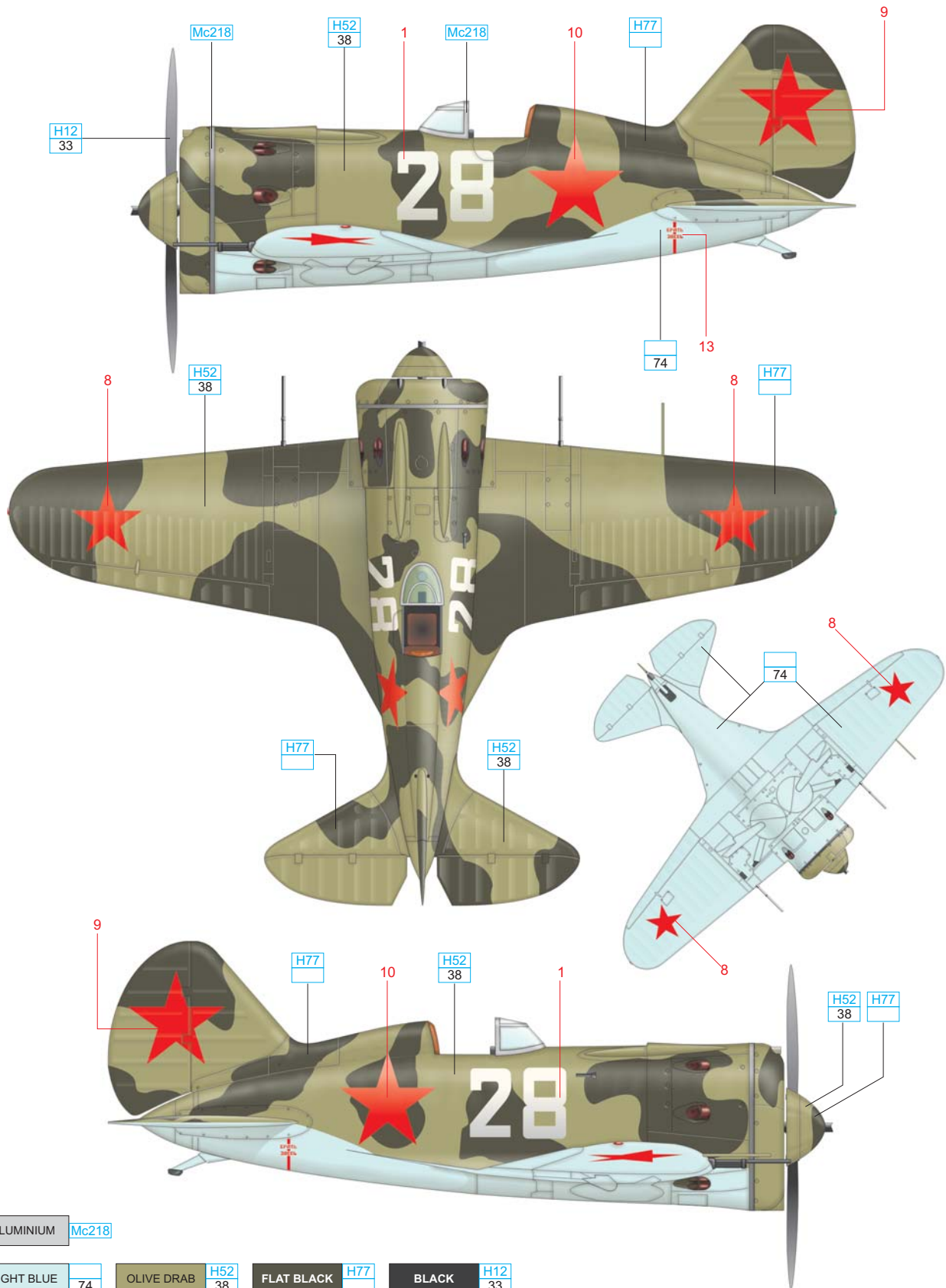

ALUMINIUM Mc218

LIGHT BLUE 74

OLIVE DRAB H52
38

FLAT BLACK H77

BLACK H12
33

eduard