

Revell



B-17F „MEMPHIS BELLE”

1:48

Plastik-Modellbausatz
Plastic modelkit
Modèle réduit
Modelbouwdoos

← 49,4 cm
○ 65,6 cm

Flugzeug-Illustration,
Aircraft-illustration,
Illustration d'un avion,
Vliegtuig-illustratie:
Egbert Friedl

04297

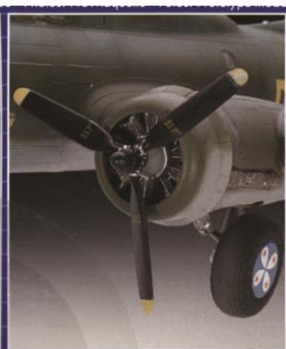



B-17F „MEMPHIS BELLE“

04297-0389

© 2008 BY REVELL GmbH & CO. KG

PRINTED IN GERMANY



B-17F „MEMPHIS BELLE“

Die Boeing B-17 wurde im 2. Weltkrieg zum Synonym für die schwerbewaffneten strategischen Bomber obwohl sie mit 12 677 Maschinen noch längst nicht die am meisten gebaute Maschine dieser Art war. Ihren Namen „Flying Fortress“ erhielt sie von einem amerikanischen Journalisten nach dem Erstflug und er blieb ihr erhalten. Was in der Geschichte der B-17 meist unbekannt bleibt : Sie wurde zur Geburtsstunde der Checklisten - ohne die in der Fliegerei kaum noch Jemand auskommt. Der Anlass war ein Unfall während der Prototypenerprobung der zur Zerstörung der Maschine führte. Die Besatzung hatte vergessen die vom Cockpit aus zu bedienende Feststellvorrichtung der riesigen Quer- und Höhenrudern zu lösen. Um einem ähnlichen Fehler vorzubeugen führte Boeing die erste Checkliste ein. Die Boeing B-17F war auch die erste Flying Fortress die in Massenproduktion hergestellt wurde. Neben den 2300 Maschinen die bei Boeing gebaut wurden fertigte Vega in Burbank, Kalifornien 500 Maschinen und Douglas baute in Long Beach, Kalifornien weitere 605 B-17F. Die berühmteste Maschine aus dieser Baureihe war die bei Boeing gefertigte B-17F-10-BO die am 15. Juli 1942 ausgeliefert und am bei der 324th Bomber Squadron, 91st Bomber Group in Basingstow, England in Dienst gestellt wurde. Von ihrer Besatzung erhielt sie den Namen „Memphis Belle“, nach der Freundin des Piloten Lt. Robert K. Morgan. Ihre Berühmtheit resultierte aus der Tatsache das sie offiziell als erster Bomber der US Army Air Force in Europa 25 Einsätze überlebte und zum Star eines Hollywood Propaganda-Films von William Wyler wurde, der 1943 in die Kinos kam. In Wirklichkeit war es jedoch die B-17F-25-BO „Hell's Angels“ (41-24577) von der 365th Bomber Squadron; 305th Bomber Group die am 13. Mai 1943 dieses Ziel erreichte. Die „Memphis Belle“ hingegen flog ihren 25th Einsatz erst am 17. Mai 1943 bei einem Angriff auf die deutsche U-Boot Basis Lorient, Frankreich. Nach diesem Einsatz wurde die „Memphis Belle“ mit ihrer Besatzung in die USA beordert um mit ihrer Popularität für die Zeichnung von Kriegsanleihen zu werben und um die Moral der amerikanischen Arbeiter in den Rüstungsbetrieben zu heben. Vor und während der Tour durch die USA erhielt die „Memphis Belle“ zahlreiche Änderungen an ihrem Aussehen. Besonders die Namen der Besatzungsmitglieder wurden erst zu einem späteren Zeitpunkt angebracht. So hat der Modellbauer bei diesem Bausatz die Wahl unter verschiedenen Alternativen. Die „Memphis Belle“ ist die älteste B-17 die erhalten geblieben ist. Nach dem Krieg wurde sie von der Stadt Memphis „gekauft“ und unter freiem Himmel als Denkmal aufgestellt - was ihrem Erhaltungszustand nicht besonders förderlich war. Bei der „Restaurierung“ gingen dann auch noch die letzten erhalten gebliebenen Originalzeichnungen und Markierungen verloren. Am 29. September 2004 machte das National Museum der USAF von seinem Besitzrecht gebrauch und ordnete die Rückführung der „Memphis Belle“ nach Wright-Patterson AB an. Hier wurde die B-17F einer kompletten Restaurierung unterzogen wobei sehr viel Wert auf die originalgetreue Wiederherstellung aller Markierungen verwendet wurde. Heute ist die „Memphis Belle“ wieder der Öffentlichkeit zugänglich.

Technische Daten:

Spannweite	31,63 m
Länge	22,78 m
Höhe	5,82 m
Motoren	4 x Wright Cyclone R-1820-97
Leistung	1 200 PS
Notleistung	1 380 PS
Leistung in 8 000 m	1 000 PS
Basisgewicht	15 876 kg
Startgewicht max.	29 484 kg
Reisegeschwindigkeit	297 km/h
Höchstgeschwindigkeit	526 km/h
Dienstgipfelhöhe	11 734 m
Bewaffnung	8 x 453 kg Bomben oder bis zu 24 x 45,3 kg Bomben 13 MG Kaliber 12,7 mm
Besatzung	10 Mann

B-17F „MEMPHIS BELLE“

During the Second World War the Boeing B-17 became synonymous with the heavily armed strategic bomber even though with a total of 12677 aircraft built, it was not the most prolific aircraft of this type. It received its name „Flying Fortress“ from an American journalist after its maiden flight and never lost it. A fact that is mostly forgotten in the history of the B-17 is the introduction of Check Lists or Flight Reference Cards, without which almost no-one in modern aviation takes to the air. The reason for this was an accident during prototype testing which led to the aircraft being destroyed. The crew had forgotten to release a locking arrangement for the enormous rudder and elevator which was controlled from the cockpit. In order to prevent further mistakes of this nature Boeing introduced the first „Flight Reference Cards“.

The Boeing B-17F was also the first Flying Fortress to be built in mass production. As well as the 2300 aircraft built by Boeing, Vega of Burbank, California built a further 500 aircraft and Douglas a further 605 B-17S at Long Beach California.

The most famous aircraft of this type was the B-17F-10-BO built by Boeing. It was delivered on 15 July 1942 and went into service with the 324th Bomber Squadron of the 91st Bomber Group in Basingstow, England. Her crew named her „Memphis Belle“ after the girl friend of her pilot Lt Robert K. Morgan. She achieved fame as a result of officially being the first bomber of the US Army Air Force to have survived 25 missions in Europe. She became the star of a Hollywood propaganda film from William Wyler which appeared in the cinemas in 1943. It was in reality however the B-17F-25-BO „Hell's Angels“ (41-24577) of the 365th Bomber Squadron, 305th Bomber Group which achieved this record on 13th May 1943. The „Memphis Belle“ however flew her 25th mission during an attack on the German U-Boat Base at Lorient in France on 17th May 1943. After this mission the „Memphis Belle“ and her crew were recalled to the USA in order to use their popularity to advertise for the emission of War Bonds and to increase the moral of workers in the American War factories.

Before and during its tour of the USA the „Memphis Belle“ received many changes to her appearance. In particular the crew's names were applied at a later date. The modeller therefore has the choice of many alternative liveries with this kit.

The „Memphis Belle“ is the oldest remaining B-17. After the War she was „bought“ by the city of Memphis and erected as a monument in the open, which was not particularly good for the aircraft's condition. The last remaining original designs and markings were lost during this „restoration“. On 29th September 2004 the National Museum of the USAF from invoked its ownership rights and ordered the return of the „Memphis Belle“ to Wright-Patterson Air Base. Here, the B-17 underwent a complete restoration whereby much emphasis was placed on the restoration of all the original markings. Today the „Memphis Belle“ is once again open to the public.

Technical Data:

Wingspan:	31,63m (103ft 9ins)
Length:	22,78m (74ft 9ins)
Height:	5,82m (19ft 1ins)
Engines:	4 x Wright Cyclone R-1820-97
Power Rating:	1 200hp
Emergency Power Rating:	1380hp
Power Rating at 25000ft:	1000hp
Empty Weight:	15876 kg (35007 lbs)
Maximum Take-off Weight:	29484 kg (65012 lbs)
Cruising Speed:	297km/h (184mph)
Maximum Speed:	526km/h (326mph)
Service Ceiling:	11734m (38500ft)
Armament:	8 x 453kg (1000 lbs) Bombs or up to 24 x 45,3kg (100 lbs) Bombs 13 X 12.7mm Cal Machine Guns
Crew:	10

Form hergestellt und im Eigentum von Revell GmbH & Co. KG. Widersrechtliche Nachahmungen werden gerichtlich verfolgt.

© produit est propriété de la société Revell GmbH & Co. KG. Toute utilisation ou duplication frauduleuse sera foyet de poursuites en justice.

Modelado y se propiedad de Revell GmbH & Co. KG. Imitaciones ilícitas serán perseguidas por la ley.

Forma prodotta dalla Revell GmbH & Co. KG. e d' appropriati della stessa impresa, la quale procederà legalmente contro ogni imitazione abusiva.

Modell on Revell GmbH & Co. KG. valmistamä ja omisuutta. Laittoomaan kopiointiin tuliaan puuttumaan oikeudellisiin toimin.

Formen er produceret og ejes av Revell GmbH & Co. KG. Efterligning eller tilkøbe se vil bli gjerdet for rettelig forligning se.

Produkcja i prawa własności firmy Revell GmbH & Co. KG. Niezgodne podrobienie jest zabronione pod odpowiedzialnością sądową.

Model, Revell GmbH & Co. KG. firmasının mülkiyetinde imal edilmiştir. Kanuna aykırı taklifler mahkumetce takip edilecektir.

A forma stvorená je a tulajdonjog círközza a Revell GmbH & Co. KG. A jogellenes utánczolás és hamisítványok készítése jogszabályilag tilos; a bíróságok által követelték.

Model manufactured by and property of Revell GmbH & Co. KG. Illegal imitations are subject to prosecution.

Form vervaardigd door en eigendom van Revell GmbH & Co. KG. Onrechtmatige nabootsingten worden gerechtelijk vervolgd.

Formas produzidas e de propriedade da Revell GmbH & Co. KG. Cópias não autorizadas serão processadas, exclusivamente como determinadas na lei.

Modellen tillverkad av och tillhör Revell GmbH & Co. KG. All kopiering beivras enligt lagen om upphovsrätt.

Formen er framstillet af Revell GmbH & Co. KG. som også har ejendomme. Lovstridige efterligninger straffes.

Modelle stvorená je a vlastníctvo spoločnosti Revell GmbH & Co. KG. Preto vznikajúce podrobne preskúmané a súrovnávané kopie.

Forma je proizvedena i u vlasništvo firme Revell GmbH & Co. KG. Sv nepovršene kopiranje će biti kažnjeno od nadležnih vlasti.

Forma je proizvedena i je u vlasništvo Revell GmbH & Co. KG. Neovlašćene kopije bodo pravno kažnjene.

Benötigte Farben / Used Colors

Benötigte Farben Required colours	Peintures nécessaires Benodigde kleuren	Pinturas necesarias Tintas necessárias	Colori necessari Använda färger	Tarvittavat värit Du trenger følgende farger	Nødvendige farger Необходимые краски	Potrzebne kolory Απαιτούμενα χρώματα	Gerekti renkler Potřebné barvy	Szükséges színek Potrebne barve														
A farngrün, seidenmatt 360 green, silky-matt vert fougère, satiné mat varengroen, zijdemat verde helecho, mate seda verde feto, fosco sedoso verde felce, opaco seta ornbunksgrön, sidenmatt sarjaisenvihreä, silkinhimmeä bregnegron, silkematt зелен, папоротник, шелк.-матовый zielony paproć, jedwabisto-matowy πράσινο φτέρης, μεταξωτό ματ egreitt oju yesilli, ipek mat kapradinovë zeleña, hedvábne mat. páfrányzöld, selyemmatt paprot zelena, svila mat	B anthrazit, matt 9 anthracite grey, matt anthracite, mat antraciet, mat antracita, mate antracite, fosco antracite, opaco antracit, matt antrasitti, himmeä koksgrå, mat antrasitt, matt антрацит, матовый antracyt, matowy ανθρακί, ματ antrasit, mat antracit, matná antracit, matt tamno siva, mat	C grau, matt 57 grey, matt gris, mat grijs, mat gris, mate cinzento, fosco grigio, opaco grå, matt harmaa, himmeä grå, mat grå, matt серый, матовый szary, matowy γκρι, ματ grí, mat šedá, matná szürke, matt siva, mat	D rost, matt 83 rust, matt rouille, mat roest, mat orin, mate ferrugem, fosco color ruggine, opaco rost, matt ruoste, himmeä rust, matt rust, matt ржавчина, матовый rdzawy, matowy χρώμα σκουριάς, ματ pas rengi, mat rezavá, matná rozšda, matt rjava, mat	E aluminium, metallic 99 aluminium, metallic aluminium, métallique aluminium, metallic aluminio, metalizado aluminio, metálico aluminio, metalico aluminium, metallic aluminium, metalik aluminium, metallic aluminium, metalik aluminium, metalik алюминий, металлический aluminium, metaliczny αλουμίνιο, μεταλλικό aluminium, metalik aluminium, metalik aluminium, metalik aluminium, metalik	F 90 % Gelboliv, matt 42 + Yellow olive, matt Olive jaunâtre, mat Geelolijf, mat Amarillo oliva, mate Amarelo-oliva, mate Giallo oliva, opaco Guloliv, matt Oliivinkeltainen, matta Gul oliven, mat Guloliven, matt Желто-оливковый, матовый Oliivkokozyty, matowy Κίτρινο λαδί, ματ Sary zeytin yesilli, mat Žlutá, matná Žlutoolivová, matná Rumenoolivna, brez leska	G 10 % gelb, matt 15 yellow, matt jaune, mat geel, mat amarillo, mate amarelo, fosco giallo, opaco gul, matt keltainen, himmeä gul, mat gul, matt желтый, матовый žółty, matowy κίτρινο, ματ sarı, mat žlutá, matná sárga, matt rumena, mat	H feuerrot, seidenmatt 330 fiery red, silky-matt rouge feu, satiné mat rood helder, zijdemat rojo fuego, mate seda vermelho vivo, fosco sedoso rosso fuoco, opaco seta eldród, sidenmatt tulipunainen, silkinhimmeä ilród, silkematt огненно-красный, шелк.-матовый czerwony ognisty, jedwabisto-mat. κόκκινο φωτιάς, μεταξωτό ματ ateş kırmızı, ipek mat ohnivě červená, hedvábne matná tűzpiros, selyemmatt ogénj rdeča, svila mat	I eisen, metallic 91 steel, metallic coloris fer, métallique ijzerkleurig, metallic ferroso, metalizado ferro, metalico ferro, metalico járnfärg, metallic teräksenväriäinen, metallikiilto jern, metallak jern, metallic стальной, металлический želazo, metaliczny σιδηρού, μεταλλικό demir, metalik železná, metaliza vas, metáli železna, metalik	J 60 % ocker, matt 88 + ochre brown, matt ocre, mat oker, mat ocre, mate fosco ocra, opaco ocra, matt okra (keltanulita), himmeä oker, mat oker, matt окра, матовый ochra, matowy ώχρο, ματ koyu kavunçici, mat okrově žlutá, matná okker, matt oker, mat	K 40 % braun, matt 85 brown, matt brun, mat brun, mat maróñ, mate castanho, fosco margone, opaco brun, matt ruskea, himmeä brun, mat brun, matt коричневый, матовый brązowy, matowy καφέ, ματ kahverengi, mat hnědá, matná barna, matt rjava, mat	L 70 % eisen, metallic 91 + steel, metallic coloris fer, métallique ijzerkleurig, metallic ferroso, metalizado ferro, metalico ferro, metalico járnfärg, metallic teräksenväriäinen, metallikiilto jern, metallak jern, metallic стальной, металлический želazo, metaliczny σιδηρού, μεταλλικό demir, metalik železná, metaliza vas, metáli železna, metalik	M 30 % anthrazit, matt 9 anthracite grey, matt anthracite, mat antraciet, mat antracita, mate antracite, fosco antracite, opaco antracit, matt antrasitti, himmeä koksgrå, mat antrasitt, matt антрацит, матовый antracyt, matowy ανθρακί, ματ antrasit, mat antracit, matná antracit, matt tamno siva, mat	N beige, matt 89 beige, matt beige, mat beige, mate bege, fosco beige, opaco beige, matt beige, himmeä beige, mat beige, matt бежвый, матовый beżowy, matowy μπεζ, ματ bej, mat béžová, matná bézs, matt bež (slonova kost), mat	O weiß, matt 5 white, matt blanc, mat wit, mat blanco, mate branco, fosco bianco, opaco vit, matt valkoinen, himmeä hvid, matt hvit, matt белый, матовый biały, matowy λευκό, ματ beyaz, mat bilá, matná fehér, matt bela, mat	P Hellgrau, matt 76 Light grey, matt Gris clair, mat Lichtgrijs, mat Gris claro, mate Cinzento-claro, mate Grigio chiaro, opaco Ljusgrå, matt Vaaleanharmaa, matta Lysegrå, mat Lysegrå, matt Светло-серый, матовый Jasnoszary, matowy Γκρι ανοιχτό, ματ Açik gri, mat Világosszürke, matt Svetle šedivá, matná Svetlosiva, brez leska	Q Dunkelgrün, matt 39 Dark green, matt Vert foncé, mat Donkergroen, mat Verde oscuro, mate Verde-escuro, mate Verde scuro, opaco Mörkgrön, matt Tummanvihreä, matta Merkgren, mat Merkgren, matt Темно-зеленый, матовый Ciemnozielony, matowy Πράσινο σκούρο, ματ Koyu yeşil, mat Sötétzöld, matt Tmavomodrá, matná Temnozelená, brez leska	R helloliv, matt 45 light olive, matt olive clair, mat olijf-licht, mat aceituna, mate oliva claro, fosco oliva chiaro, opaco ljusoliv, matt vaalean oliivi, himmeä lysoliv, mat lys oliven, matt светло-оливковый, матовый jasnooliwk., matowy ανοιχτό χακί, ματ açik zeytinli, mat svätéolivová, matná világos oliv, matt svetlo oliva, mat	S grau, seidenmatt 374 grey, silky-matt gris, satiné mat grijs, zijdemat gris, mate seda cinzento, fosco sedoso grigio, opaco seta grå, sidenmatt harmaa, silkinhimmeä grå, silkematt grå, silkematt серый, шелковисто-матовый szary, jedwabisto-matowy γκρι, μεταξωτό ματ grí, ipek mat šedá, hedvábne matná szürke, selyemmatt siva, svila mat	T schwarz, glänzend 7 black, gloss noir, brillant zwart, glansend negro, brillante preto, brilhante nero, lucente svart, blank musta, kiiltävä sort, skinnende sort, blank черный, блестящий czarny, blyszczący μαύρο, γυαλιστερό siyah, parlak černá, lesklá fekete, fényes črna, bleskajoča	U Schwarzen Faden benutzen Use black thread Employer le fil noir Gebruik zwarte draad Utilizar hilo color negro Utilizar fio preto Usare filo nero Använd svarta trådar Käytä mustaa lankaa Benyt en sort Bruk svart Использовать черные нитки Użyć czarnej nici χρησιμοποιήστε την καφέ μούρου Kahverengi siyah iplik kullanın Použit černé vlákno barna fekete fonalat kell használni Uporabljati črni nit	V Nicht enthalten Not included Non fourni Behoort niet tot de levering No incluido Non compresi Não incluído Ikke medsendt Ingår ej Ikke inkluderet Eivät sisälly Δεν συμπεριλαμβάνεται Не содержится Nem tartalmazza Nie zawiera Ni vsebovano İçerisinde bulunmamaktadır Neni obsaženo	X Loch bohren Make a hole Faire un trou Maak een gat Practicar un taladro Perfurar Fare un foro Borra hål Poraa reikä Der bores et hul Bor hull Просверлить отверстие wyywiercić otwór ανοίξτε τρύπα Delik açın Vyvrtat diru lyukat fürni Narediti lukinjo



Schwarzen Faden benutzen
Use black thread
Employer le fil noir
Gebruik zwarte draad
Utilizar hilo color negro
Utilizar fio preto
Usare filo nero
Använd svarta trådar
Käytä mustaa lankaa
Benyt en sort
Bruk svart
Использовать черные нитки
Użyć czarnej nici
χρησιμοποιήστε την καφέ μούρου
Kahverengi siyah iplik kullanın
Použit černé vlákno
barna fekete fonalat kell használni
Uporabljati črni nit



Loch bohren
Make a hole
Faire un trou
Maak een gat
Practicar un taladro
Perfurar
Fare un foro
Borra hål
Poraa reikä
Der bores et hul
Bor hull
Просверлить отверстие
wyywiercić otwór
ανοίξτε τρύπα
Delik açın
Vyvrtat diru
lyukat fürni
Narediti lukinjo

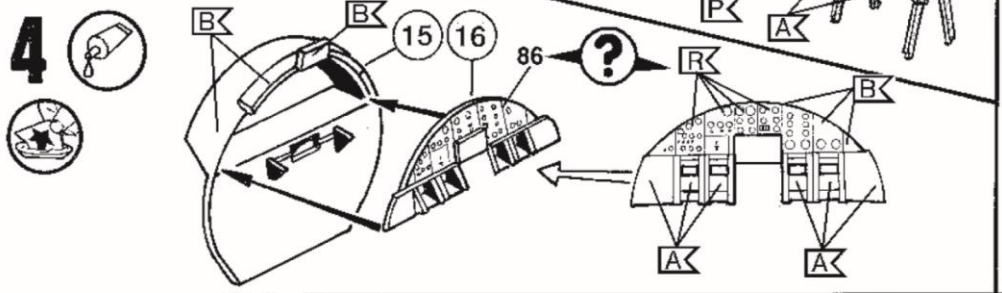
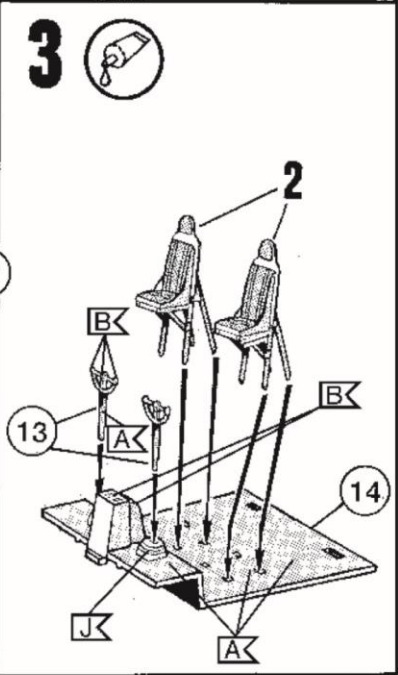
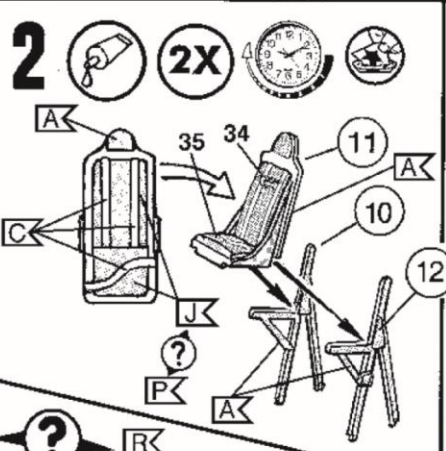
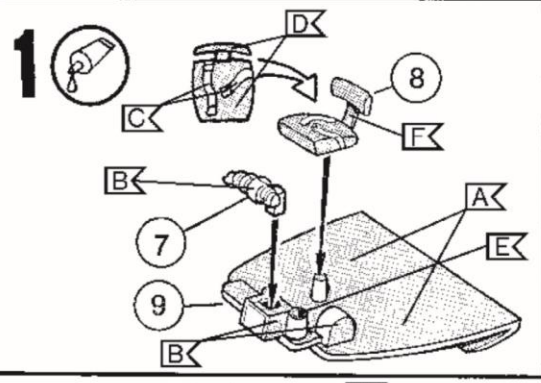
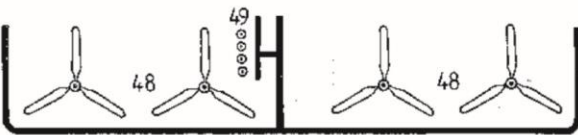
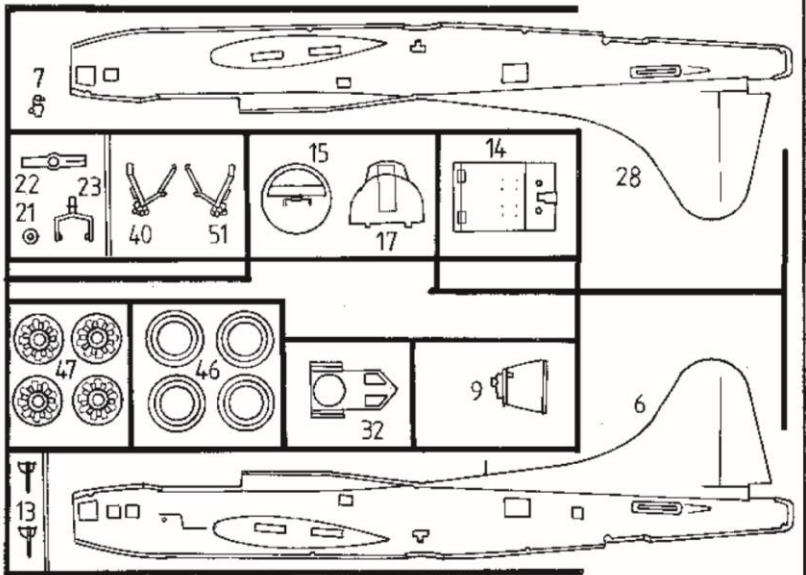
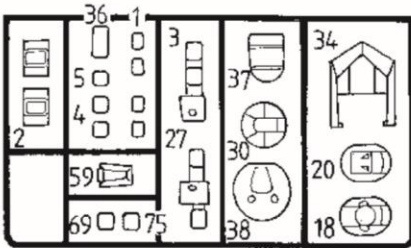
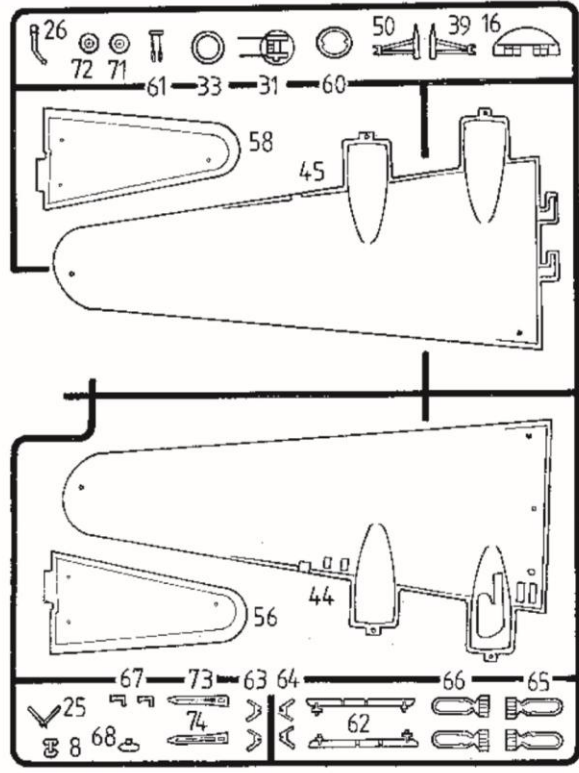
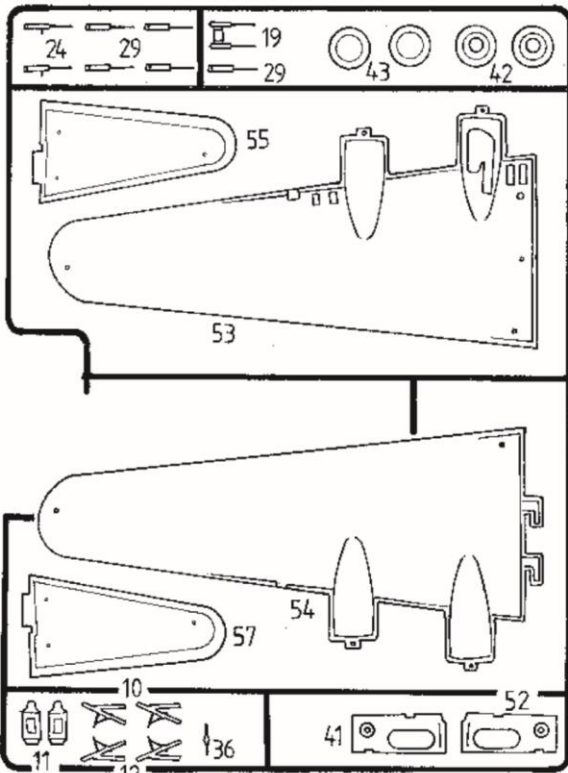

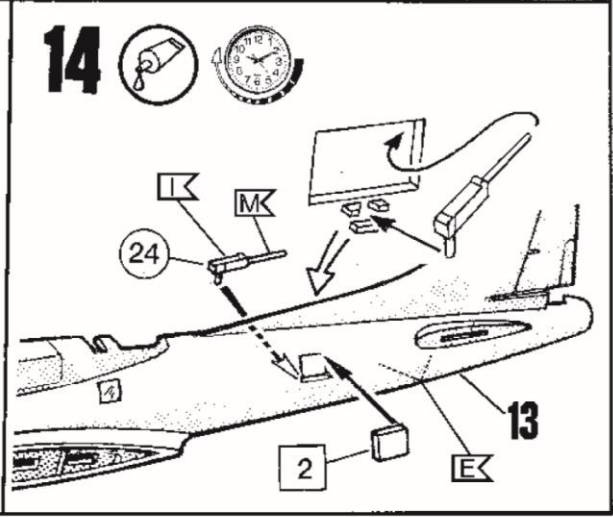
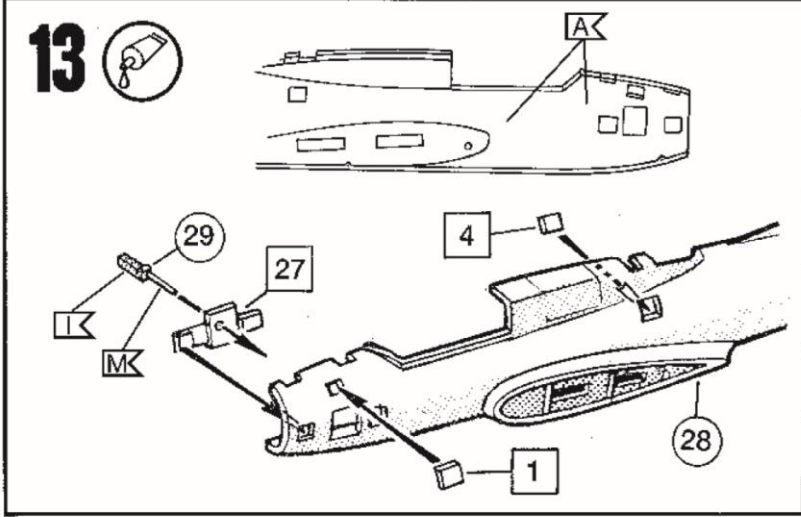
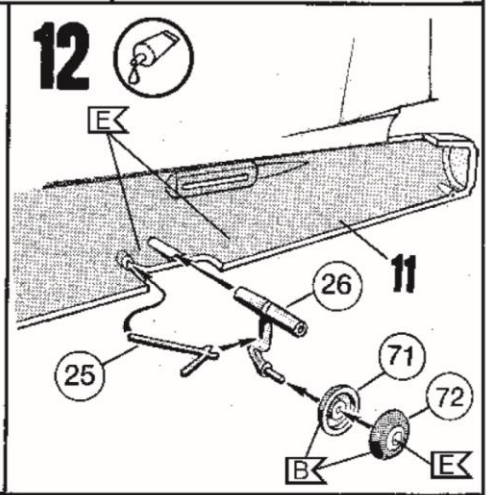
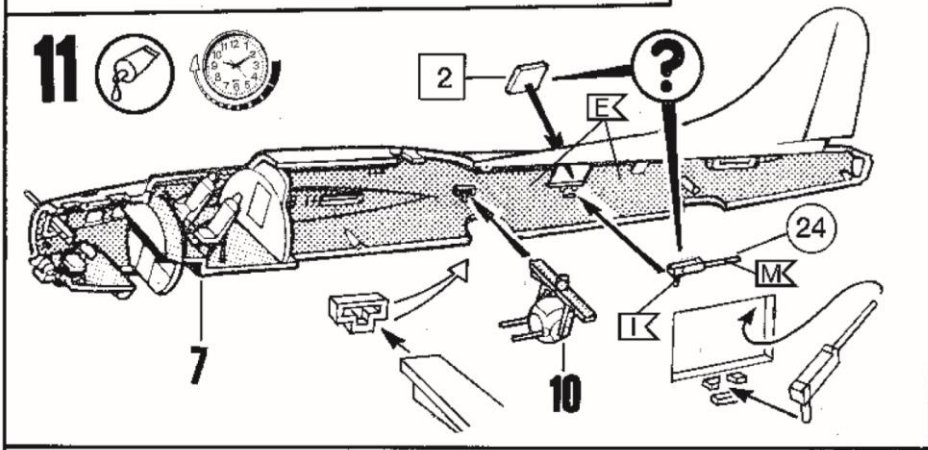
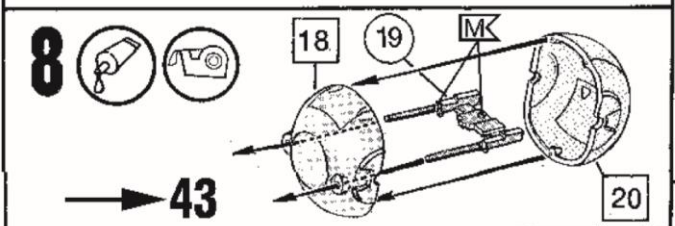
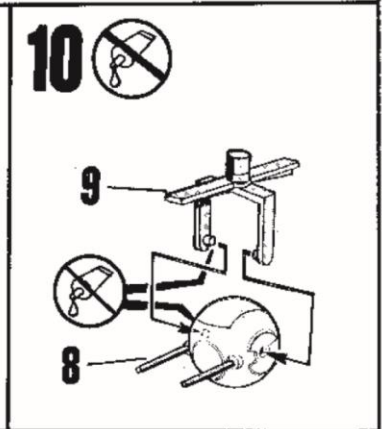
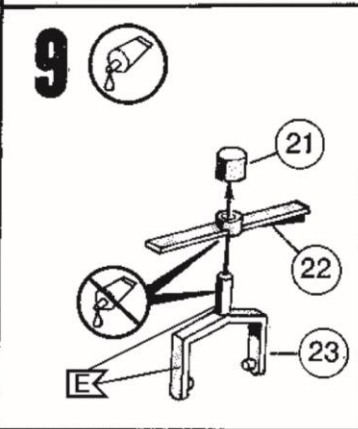
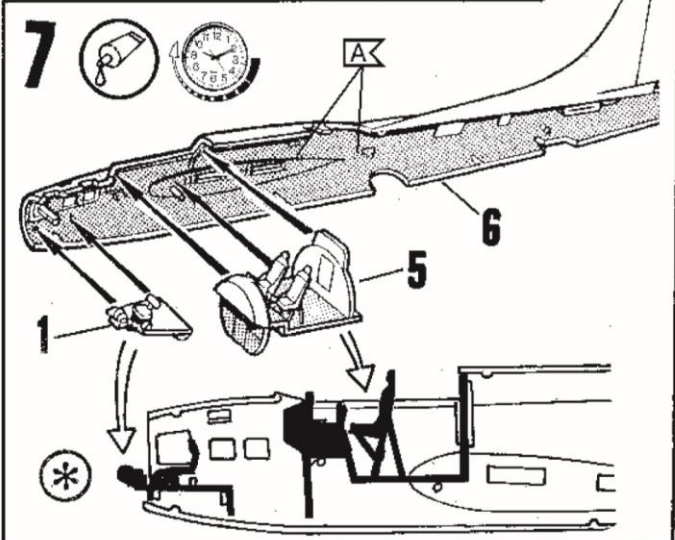
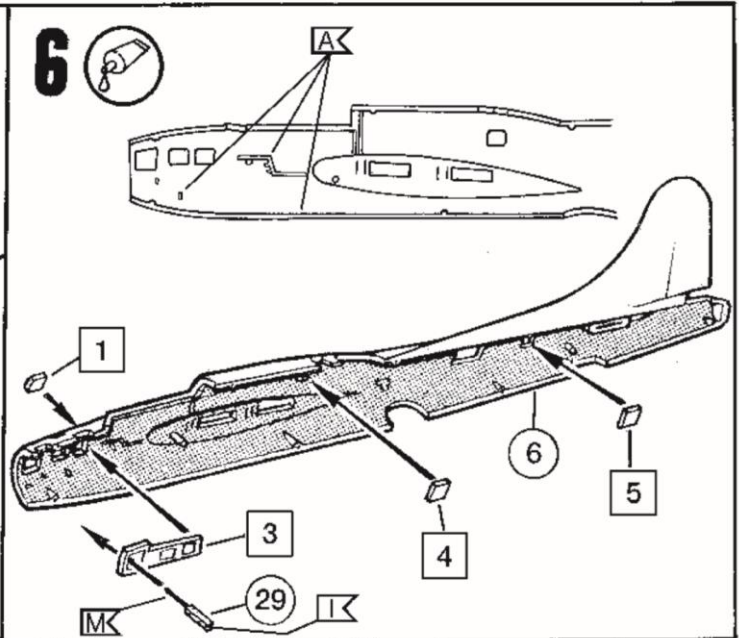
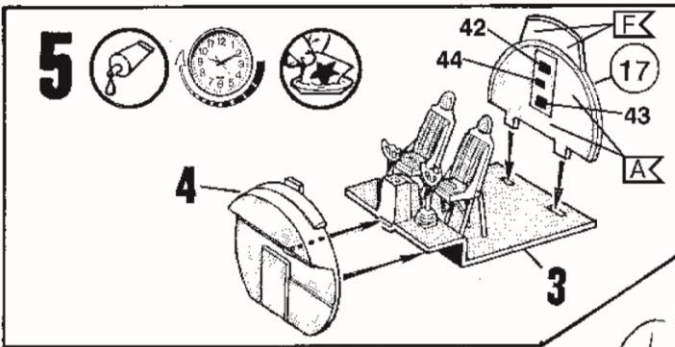

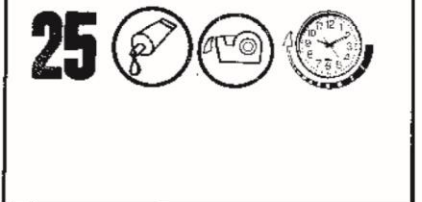
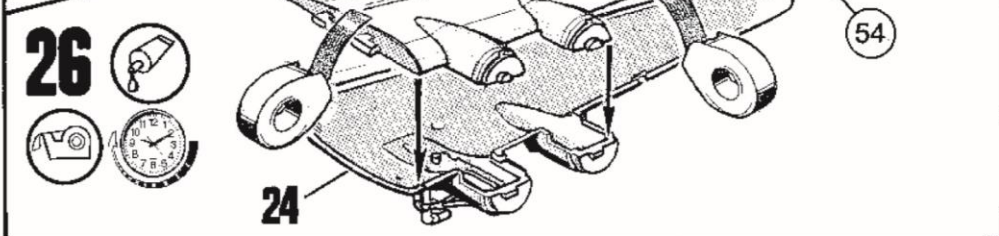
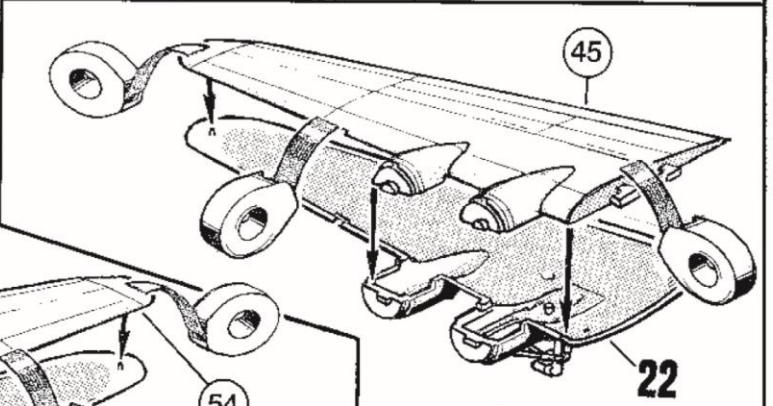
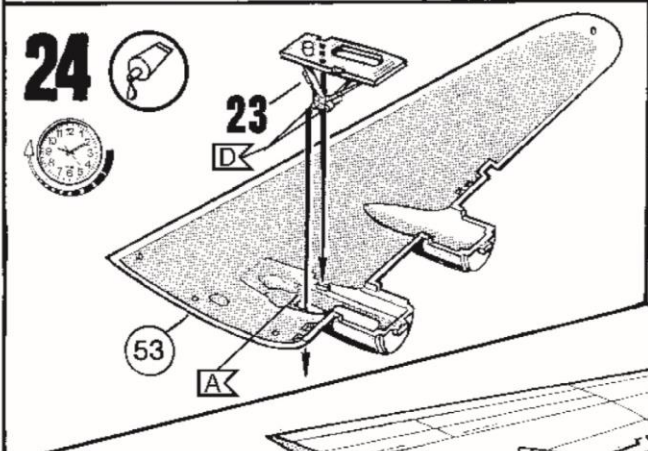
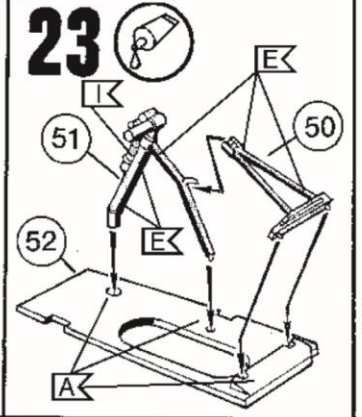
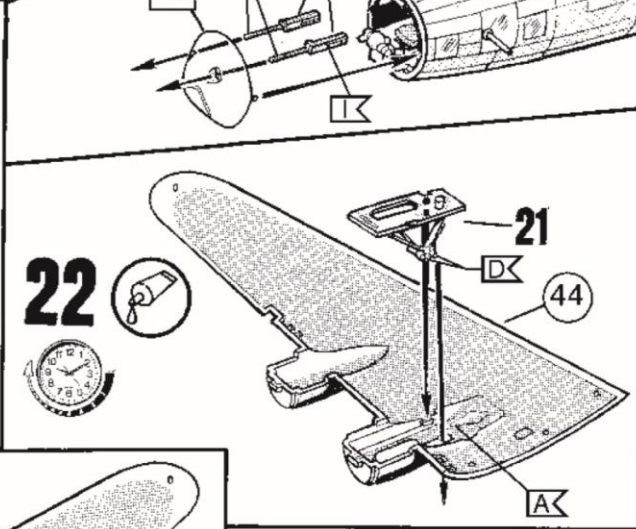
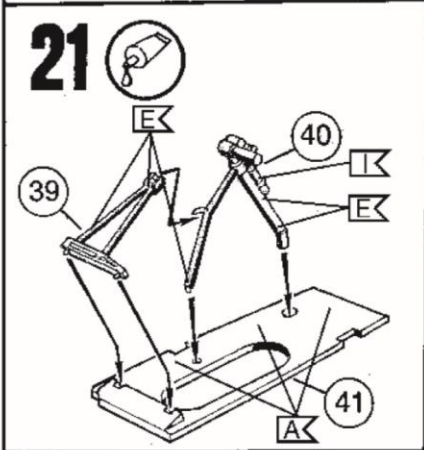
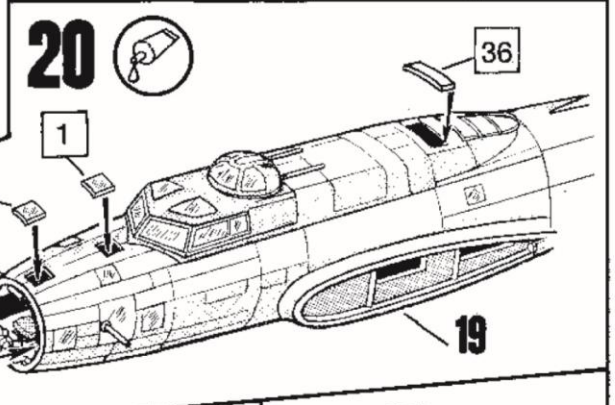
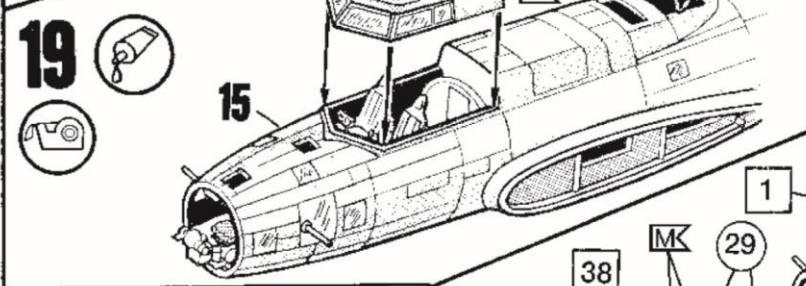
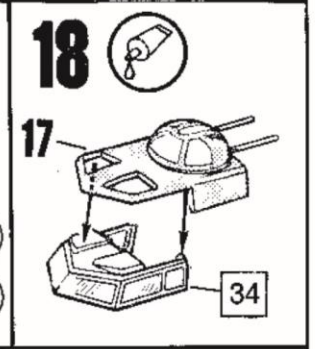
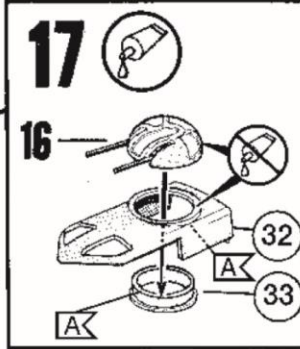
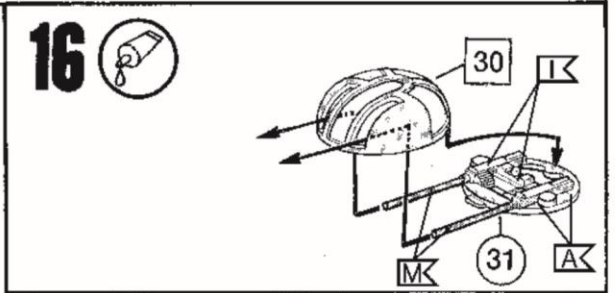
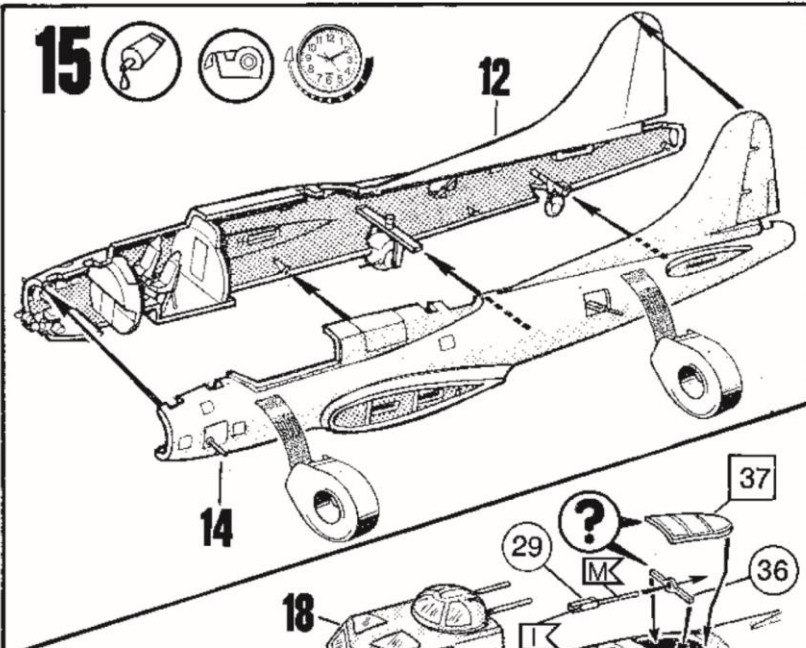

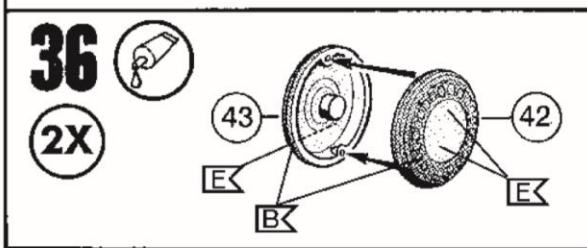
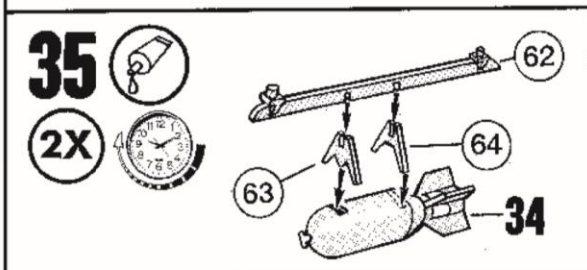
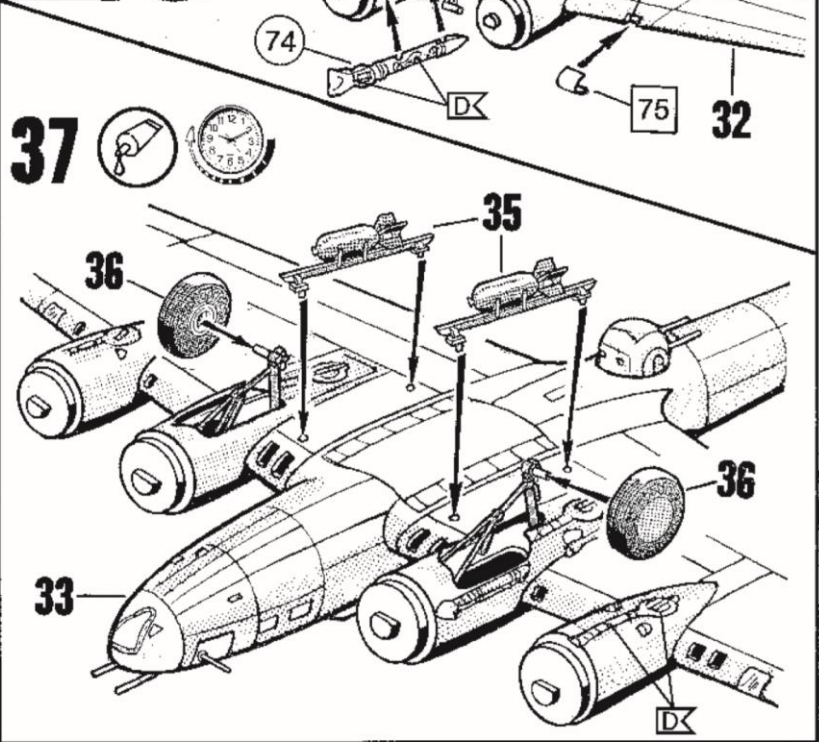
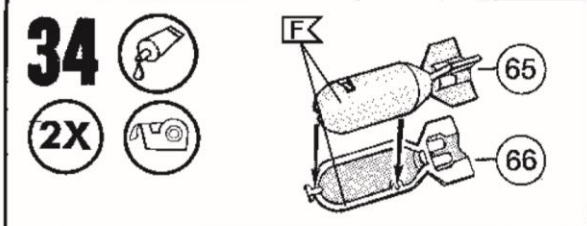
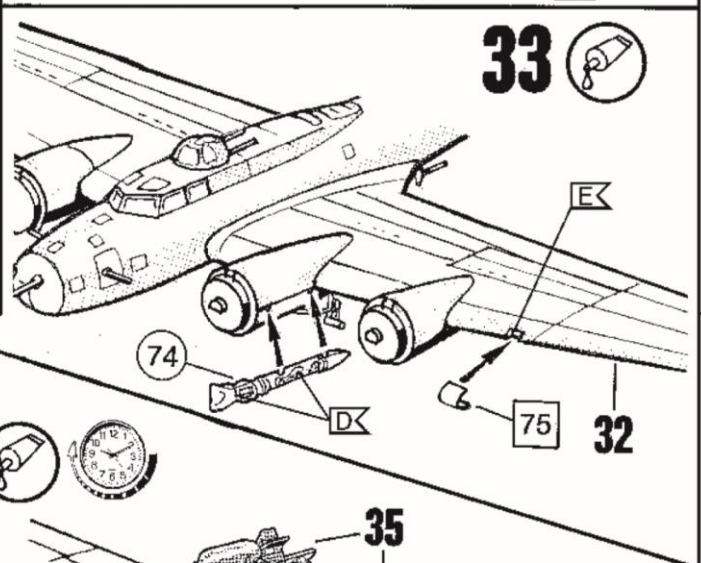
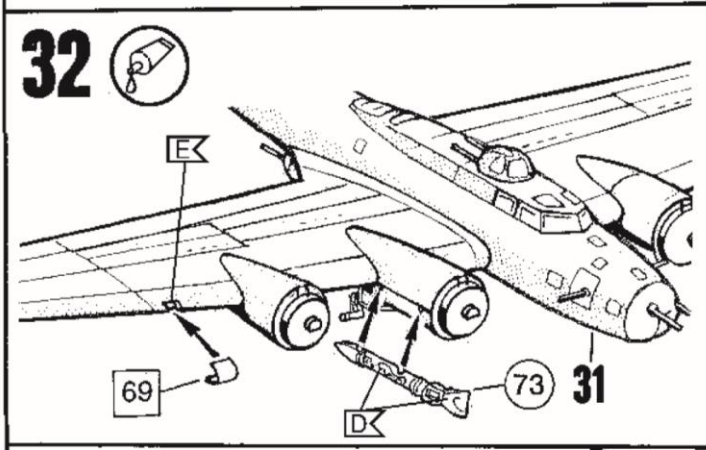
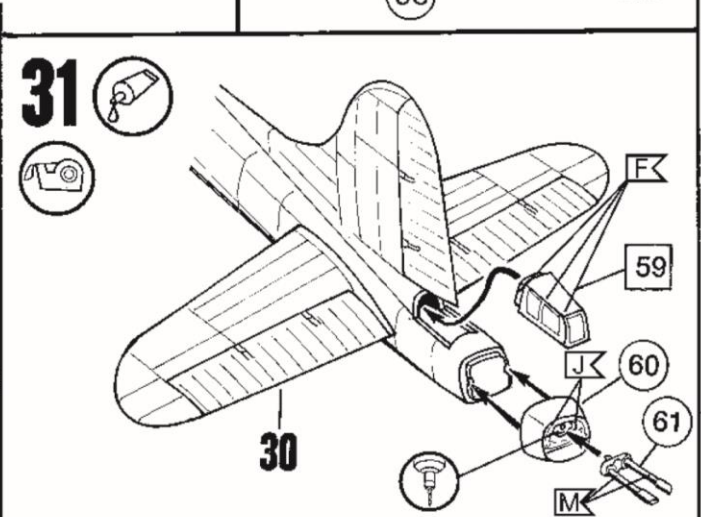
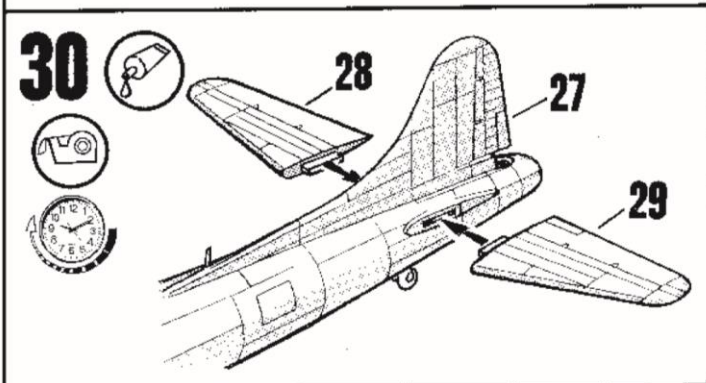
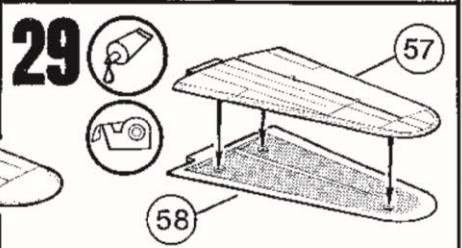
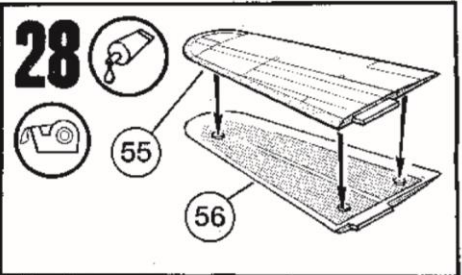
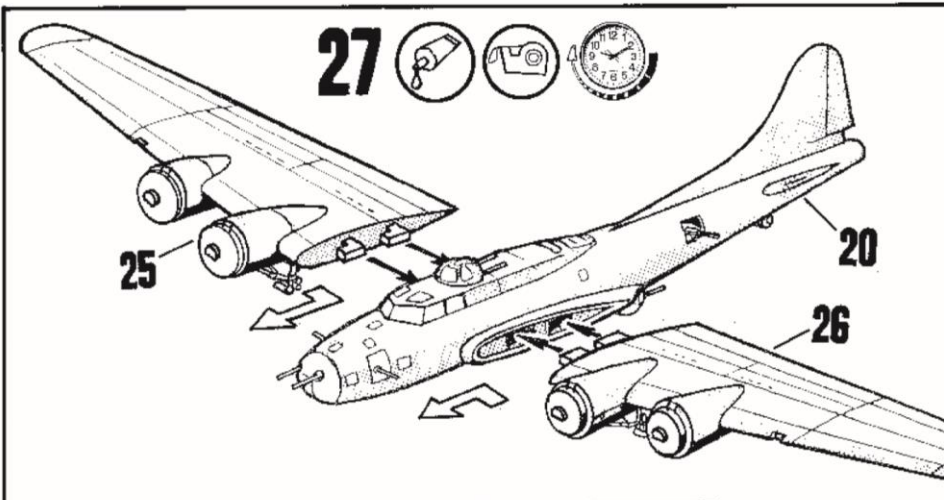

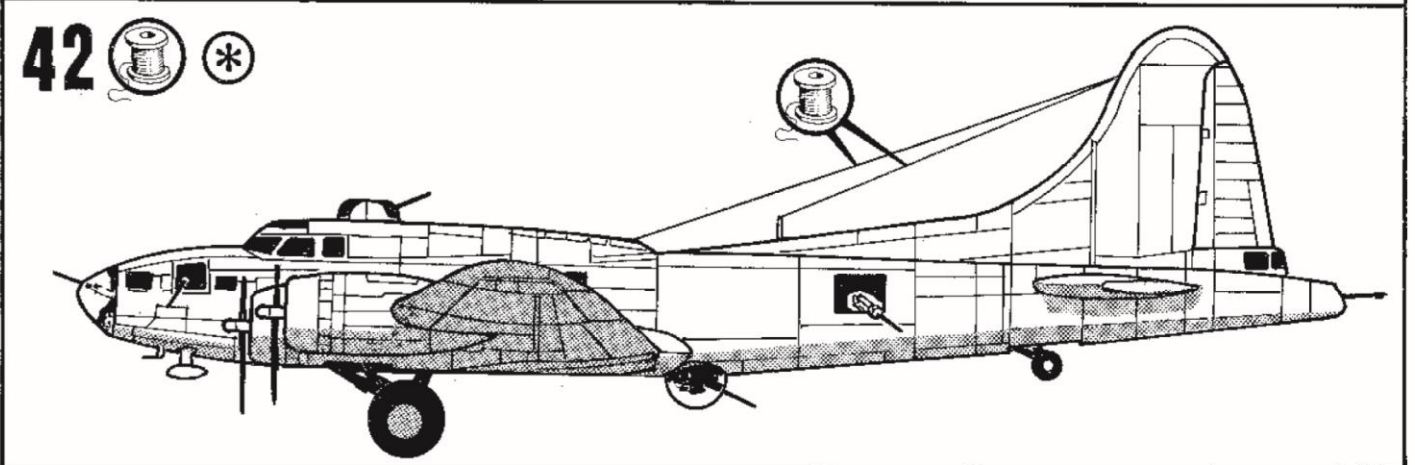
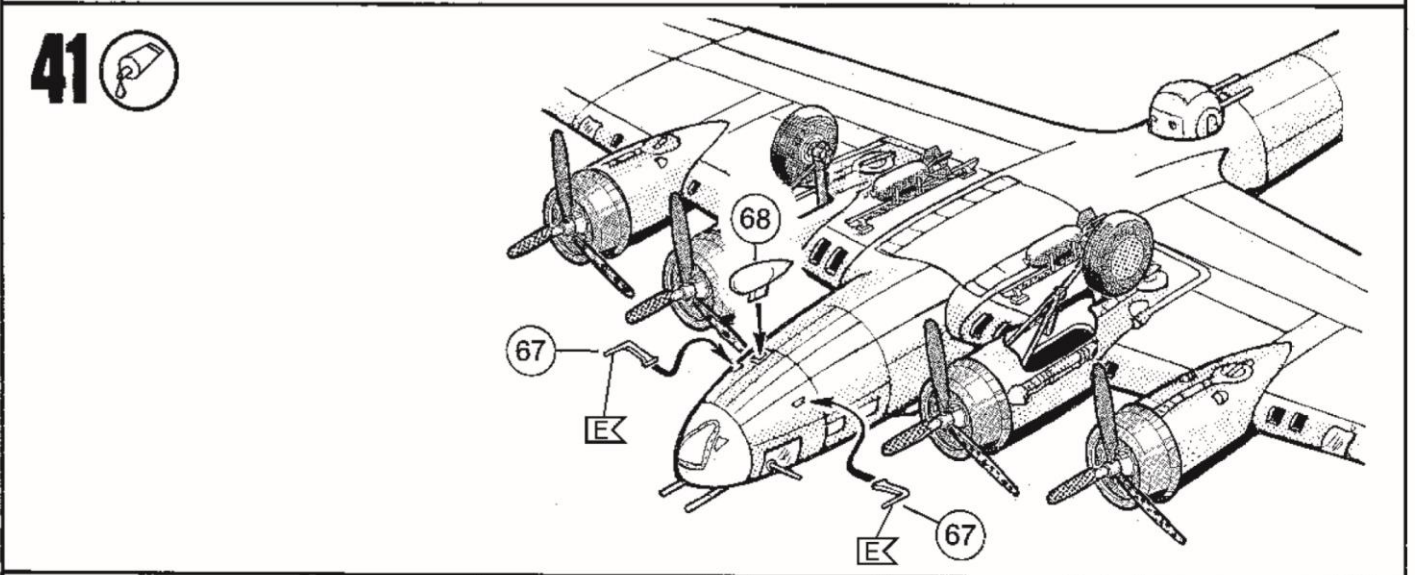
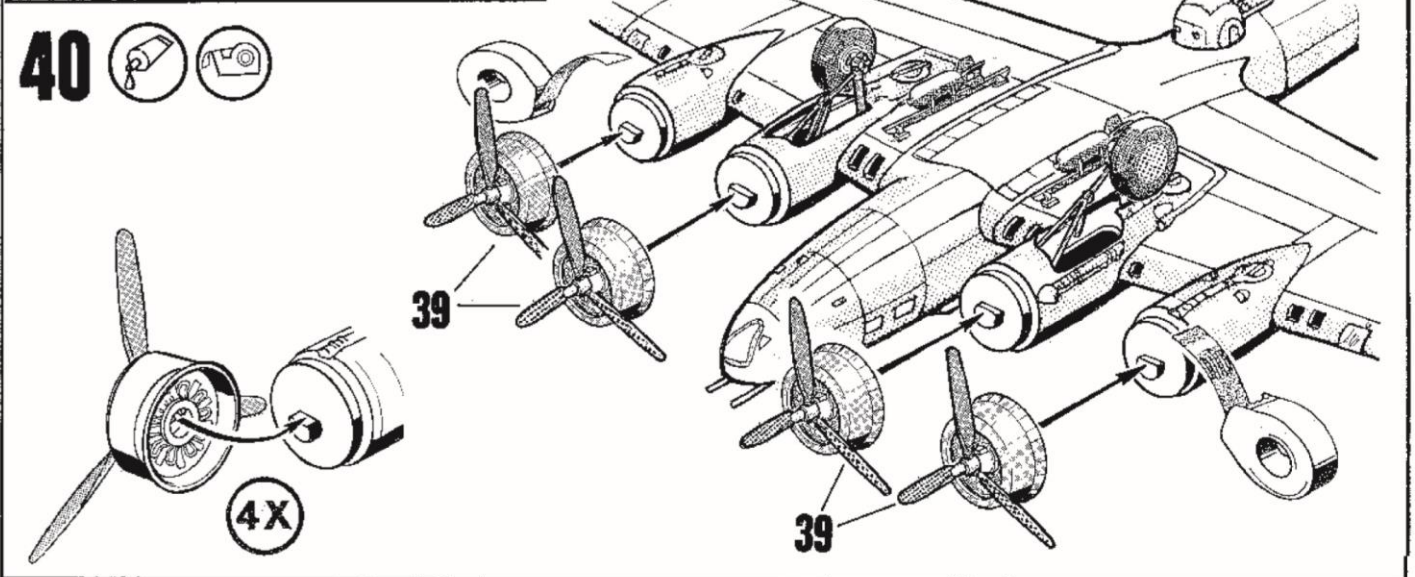
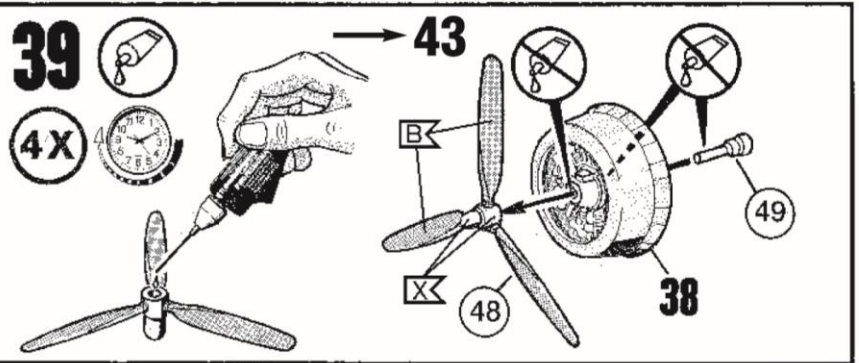
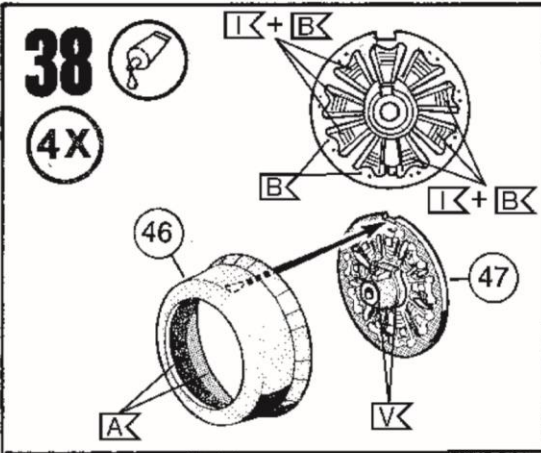

43

Boeing B17F-10-BO Flying Fortress „Memphis Belle“; of 324th Bomb Squadron, 91st Bomb Group; Basingbourn, U.K.; May 1943

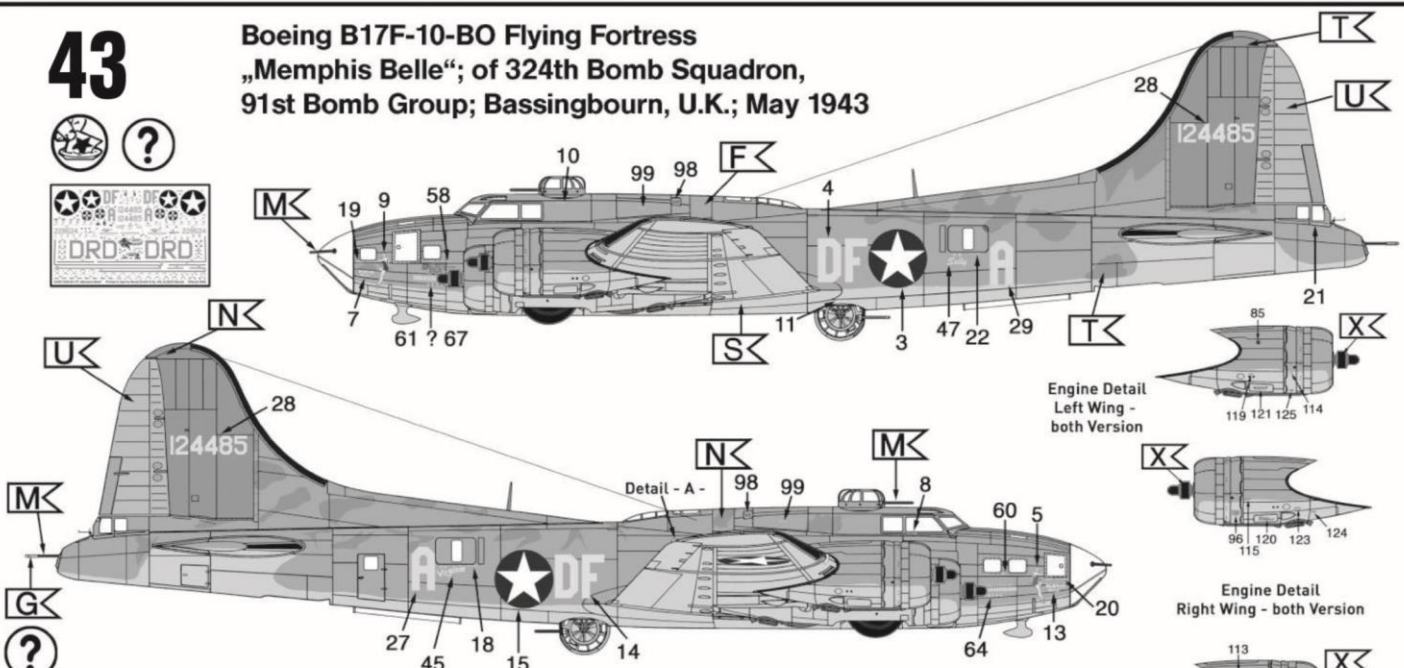

Engine Detail
Left Wing -
both Version

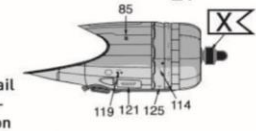

Engine Detail
Right Wing -
both Version

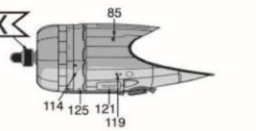
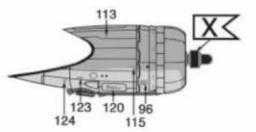
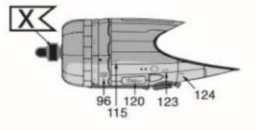

Detail - A -

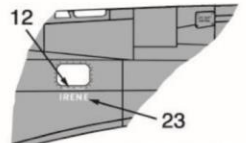

Fuselage Section
- Right Side -

B	S FS.36173	D	E	F FS.34087	H
T FS.34092	U FS.34201	X			

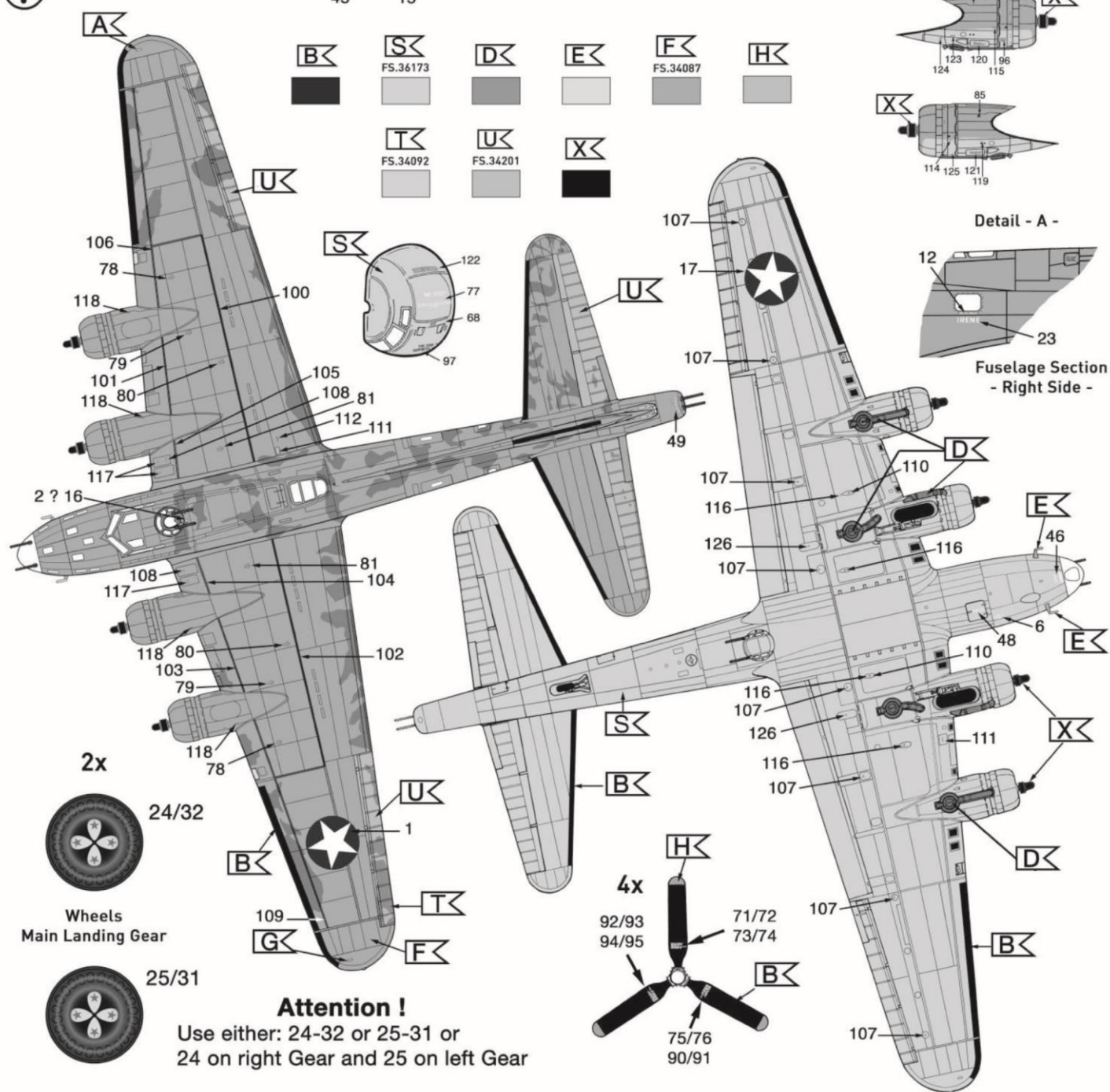

2x



24/32

Wheels
Main Landing Gear



25/31

Attention !

Use either: 24-32 or 25-31 or 24 on right Gear and 25 on left Gear

4x

