

# FIESELER FI. 156 STORCH

## /MORANE SAULNIER MS 500/502 CRIQUET

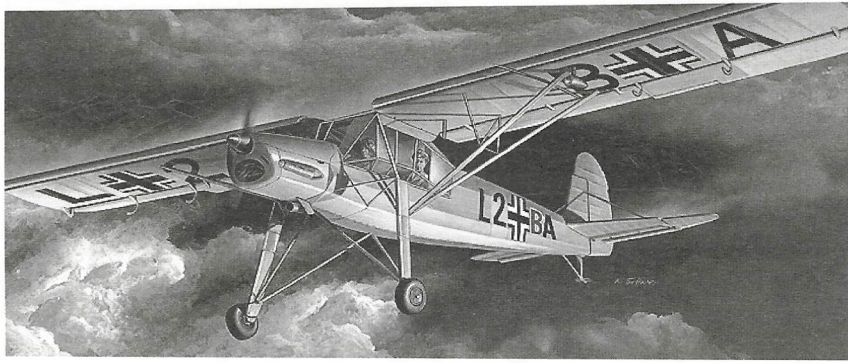

※ You can download the latest version of an instruction manual for this model by visiting [www.academyhobby.com](http://www.academyhobby.com), clicking the link for 'INSTRUCTION & DOWNLOAD' and entering the item number.  
 ※ 본 제품의 조립 중 궁금한 점은 [www.academy.co.kr](http://www.academy.co.kr) 접속 후 메뉴 '자료실' -> '프리모델' 포 이동하여 해당 제품명을 입력하면 최신의 설명서를 확인 할 수 있습니다.

1/72nd

### FIESELER FI. 156 STORCH

#### MS 500/502 CRIQUET

The Fieseler Fi156 Storch was the most successful short take-off and landing (STOL) plane used during World War II. First used in 1937. Its ability to take off from a 200 runway and land on an even shorter strip of ground made it perfect for military transport and reconnaissance missions. Its only armament was a small rear-mounted machine gun and it could only fly up to 109 mph, but this versatile plane was widely produced and used by the Luftwaffe during the war. The "Stork", as its name means in German is most famous for its daring rescue of Italian dictator Mussolini from a hotel in the Apennine mountains. Morane-Saulnier in France and Mraz in Czechoslovakia also manufactured the same plane. After the end of the war, the Morane-Saulnier company continued to produce the Fi 156 under the name MS 500/502 CRIQUET for use by the French Air Force.

Der Fieseler Storch ist bestimmt eins der berühmtesten Flugzeuge im 2. Weltkrieg, obwohl er kein Kampfflugzeug ist. Das erste erfolgreiche <Stol>-Flugzeug(kurzer Abflug und kurze Landung), wohl bekannt durch die Übersetzung von seiner deutschen Bezeichnung <Stork>, ist sicherlich das beste, hochbefeügelte Monoflugzeug, das zum Zweck von Aufklärung und Transport benutzt wurde. Der Storch wurde geschaff zwischen 1934 und 1936. Im Jahre 1937 fing er mit der Operation an. Der Storch wurde dann bald weit benutzt von all den Achsenmächten und seine Herstellung begann Frankreich, bei Mraz Cap in Tschechoslowakei sowie bei Antonov in Lithuania. In Frankreich wurde der Storch als Morane Saulnier MS-502 mit Argus 410 Motor hergestellt. Als Nachfolger von dieser letzten Version waren die MS-502's mit dem Salmsoner Sternmotor besonders wohl bekannt in der Zivilversion namens <Criquet>.

Le Fi 156 Storch était le plus célèbre des avions à décollage court de la seconde guerre mondiale. D'abord utilisé en 1937, il volait à 200 pieds et se posait sur n'importe quel terrain, si court soit-il, ce que était idéal pour le transport ou les missions de reconnaissance. Son seul armement était une petite mitrailleuse et sa vitesse n'était que de 109mph, mais sa maniabilité fut éprouvée durant la guerre. Le stock, son nom allemand, fut également utilisé durant les conflits et la libération de Mussolini. Morane Saulnier, en France, et MRAZ, en Tchécoslovaquie produisirent le même avion. Après la fin de la guerre, Morane Saulnier continua de construire le Fi 156 sous le nom de MS 500/502 CREQUET pour l'aviation française.

피제러 슈토르히는 전투기가 아님에도 불구하고, 2차 대전 당시 활약했던 항공기 중 가장 잘 알려진 기종 중 하나이다. 최초로 성공을 거둔 <스톨(짧은 이착륙)기>로, 그 독일어인 <슈토크>라는 명칭으로 유명하다. 슈토크는 정찰이나 수송의 목적으로 운용되는 전형적인 고익(高翼) 단엽기이다. 슈토르히(황새)는 1934년에서 36년 사이에 개발이 이루어져, 1937년부터 운항이 시작되었다. 슈토르히는 즉시 모든 독일 동맹국에서 폭넓게 운용되었는데, 생산 또한 프랑스를 비롯하여, 체코슬로바키아의 모라즈 캡사, 라투아니아의 안토노프사 등지에서 이루어졌다. 그 중 프랑스에서는 슈토르히가 아르구스 410 엔진을 장착한 모라느 소르니에 MS-500 라는 모델명으로 생산되었다. 이 기종의 마지막 형식인 상송 래디얼 엔진을 장착한 MS-502는 <크리케(메뚜기)>라는 명칭의 민간형으로 특히 유명하다.

12459

**<READ THIS BEFORE YOU BEGIN>**

- Study the instructions before assembling.
- Check the fit of each piece before cementing into place.
- Do not use too much cement to join parts.
- Never use cement or paint near open flame.
- Open a window or make area well ventilated when cement or paint is in use.
- Tear up and throw away the empty plastic bags to avoid danger of suffocation for little children.

**<ALLGEMEINE HINWEISE>**

- Die Anordnung der Bauteile ist aus den Zeichnungen der Anleitung ersichtlich.
- Die Teile vor dem Verkleben ungeleimt zusammenhalten, um ihren paßsitz zu prüfen.
- Klebstoff nicht zu dick auftragen.
- Klebstoff und Farben niemals in der Nähe einer Flamme verwenden.
- Während der Bemalung mit Spritzpistole oder Pinsel für frische Luftzufuhr, z.B. öffnen des Fensters, sorgen.
- Bausatz von kleinen Kindern fernhalten. Verhüten Sie, daß Kinder irgendwelche Bauteile in den Mund nehmen oder Plastiktüten über den Kopf ziehen.

**<LISEZ CE QUI SUIT AVANT DE COMMENCER LE MONTAGE>**

- Etudier les schémas d'assemblage.
- Contrôler que chaque pièce soit bien conforme avant de la coller à sa place.
- N'utilisez pas trop de colle pour réunir les pièces.
- Ne faites jamais manipuler la colle ou peinture à proximité d'une flamme.
- Aérer soigneusement la pièce où vous peignez (ouvrir la fenêtre).
- Après avoir sorti les pièces du sac en plastique, déchirer le sac afin d'éviter que les enfants ne le mettent sur la tête et ne s'étouffent.

**■ 조립하기 전에**

- 부품을 조립하기 전에 설명서를 잘 읽어본 후 조립한다.
- 부품을 자를 때에는 칼이나 나이프로 깨끗이 잘라준다.
- 접착제를 사용할 곳과 사용하지 않는 곳에 주의하고 너무 많이 바르지 않도록 한다.
- 접착하기 전에 부품을 맞추어 확인한 후 조립한다.
- 에나멜 페인트나 접착제를 사용할 때는 창문을 열어 환기를 시키고 화기를 멀리한다.
- 사용 후 남은 부품은 어린 아이들의 손에 닿지 않도록 잘 처리한다.

1

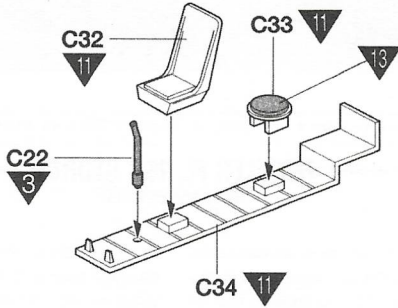

2

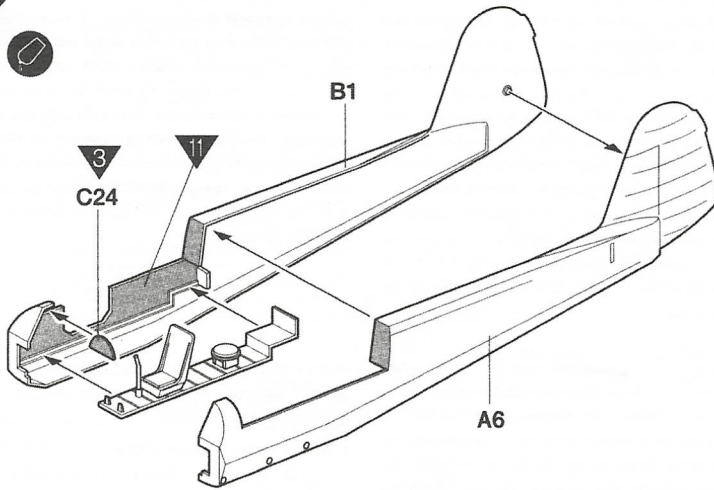

정확한다.  
Cement parts  
Coller  
Kleben



점착하지 않는다.  
Do not cement  
Ne pas coller  
Nicht kleben



3  
수만큼 조립한다.  
Repeat operation  
Répéter l'opération  
Vorgang wiederholen



잘라낸다.  
Cut away  
Couper  
Schneiden



선택한다.  
Optional parts  
Choix  
Auswahlmöglichkeit



반대측도 조립한다.  
Repeat for opposite side  
Répétition de la page  
Wiederholung für gegenüberliegende Seite

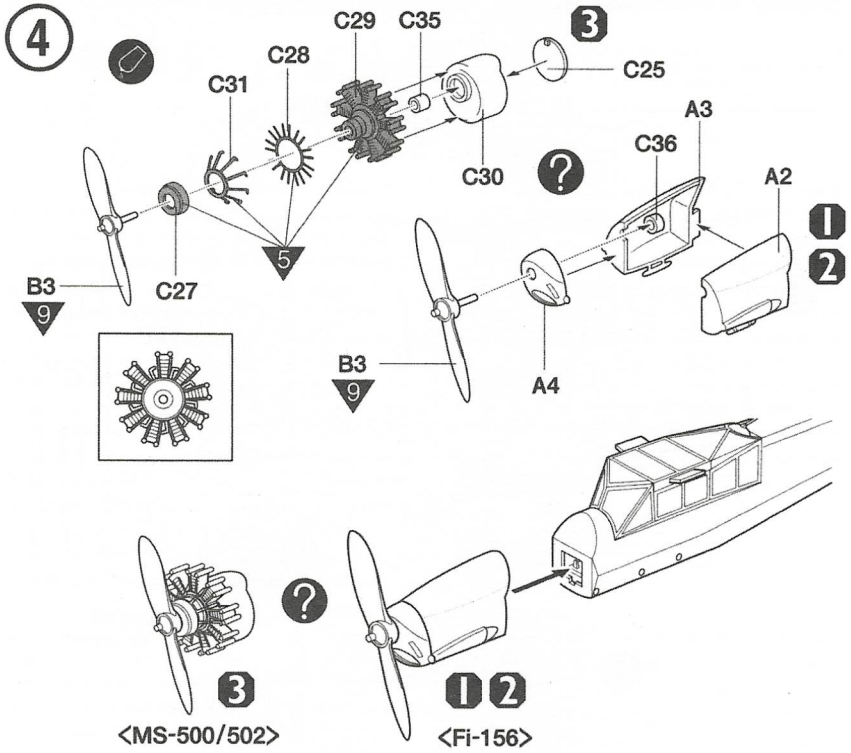
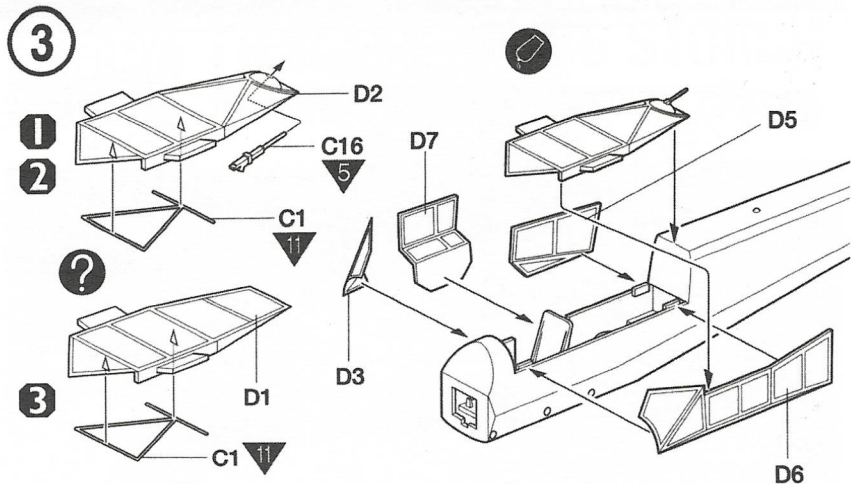

 전사지를 붙인다.  
Decals  
Décalcomanies  
Abziehbild

 무게추를 넣는다.  
Add weight  
Lester  
Gewicht

 구멍이나 홈을 메워준다.  
Use filler  
Mastiquer  
Schleifen

 구멍을 뚫어준다.  
Make hole  
Faire un trou  
Öffnen

 주의한다.  
Be careful  
Faire attention  
Hier Vorsicht

 색칠 및 전사지 붙이기 번호  
Painting scheme number  
Numeros de la liste de peintures  
Lackierschemanummer

5

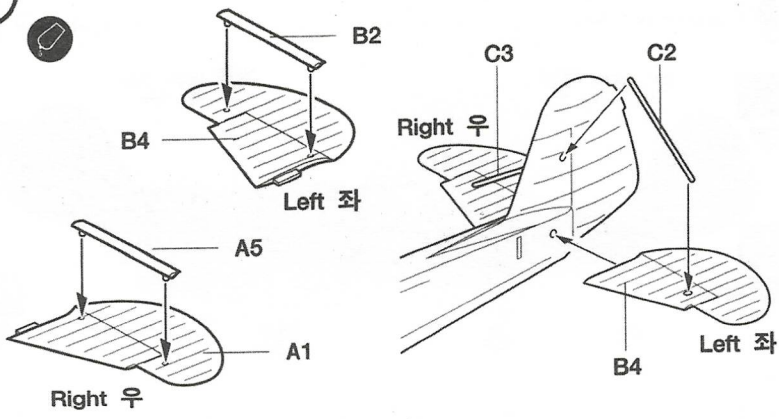

6

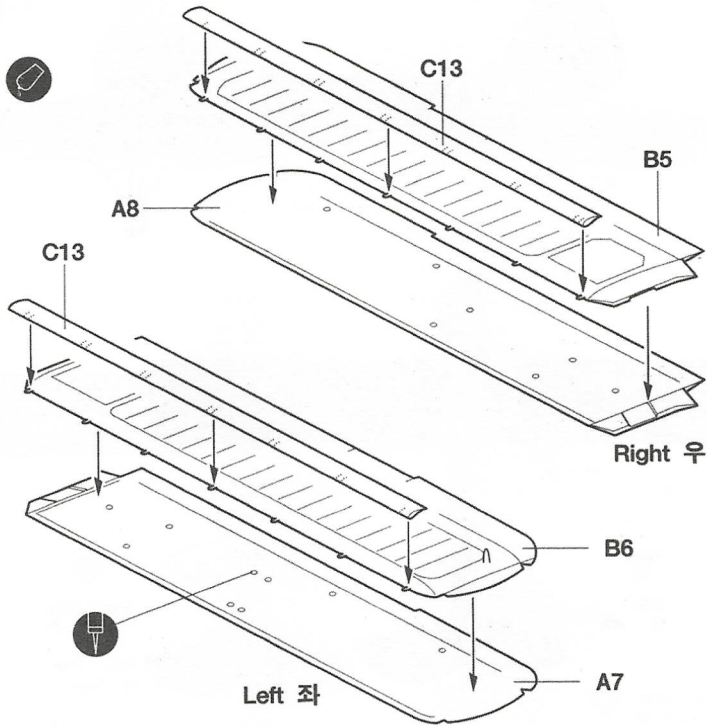

1	FLAT WHITE	MATTWEIß	BLANC MAT	무광흰색	5	METALLIC GRAY	EISENFARBIG	GRIS MÉTALLIQUE	흑철색
2	FLAT YELLOW	MATTGELB	JAUNE MAT	무광노랑색	6	CLEAR RED	ROT, REIN	ROUGE CLAIR	클리어레드
3	FLAT BLACK	MATTSCHWARZ	NOIR MAT	무광검정색	7	CLEAR BLUE	BLAU, REIN	BLEU CLAIR	클리어블루
4	SILVER	SILBER	ARGENT	은색	8	DARK GREEN (FLM 83)	DUNKELGRÜN	VERT FONCÉ	다크그린

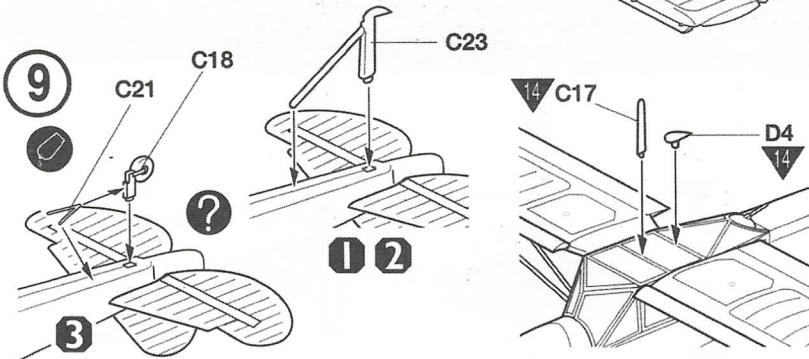
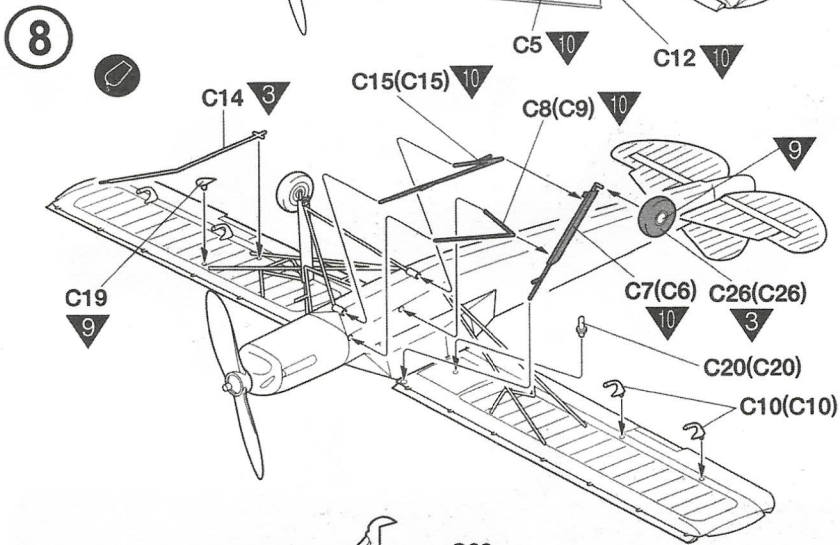
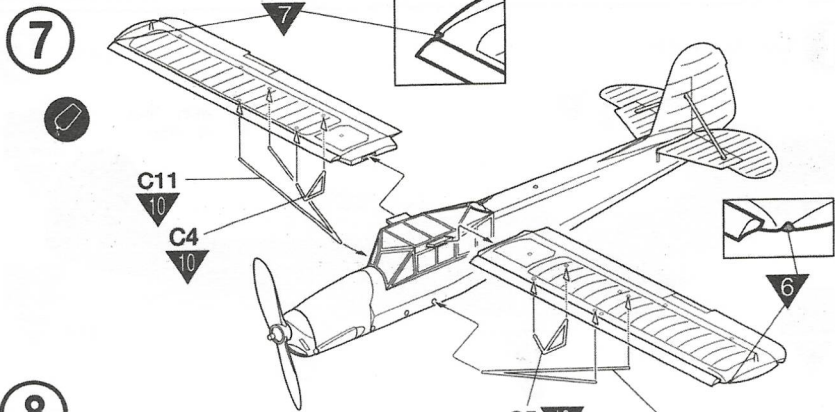

9	BLACK GREEN (RLM 70)	SCHWARZGRÜN	VERT NOIR	블랙그린	13	RED BROWN	ROTBRAUN	ROUGE BRUN	레드브라운
10	LIGHT BLUE (RLM 76)	LICHTBLAU	BLEU CLAIR	라이트블루	14	OLIVE GREEN	OLIVGRÜN	VERT OLIVE	올리브그린
11	GRAY GREEN (RLM 02)	GRAUGRÜN	VERT GRIS	그레이그린					
12	SAND BROWN	SANDBRAUN	SABLE BRUN	샌드브라운					

**I** Nort Africa 1941



11 RLM 02



12



10 RLM 76

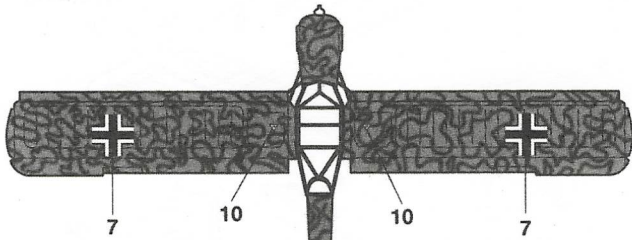
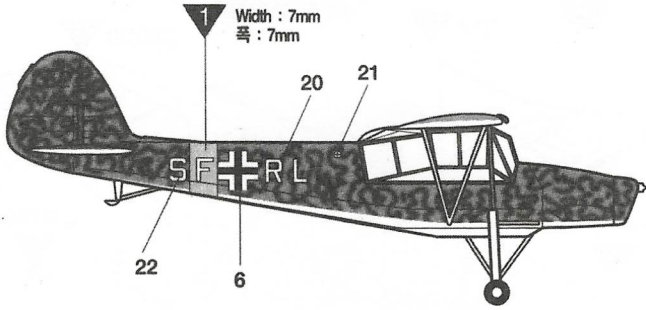
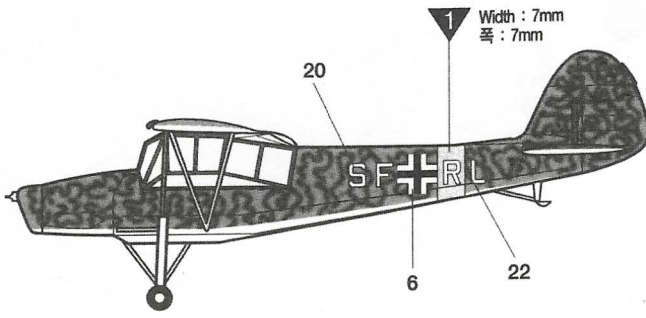

1  
Width : 7mm  
높 : 7mm

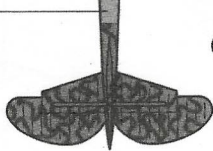

1  
Width : 7mm  
높 : 7mm

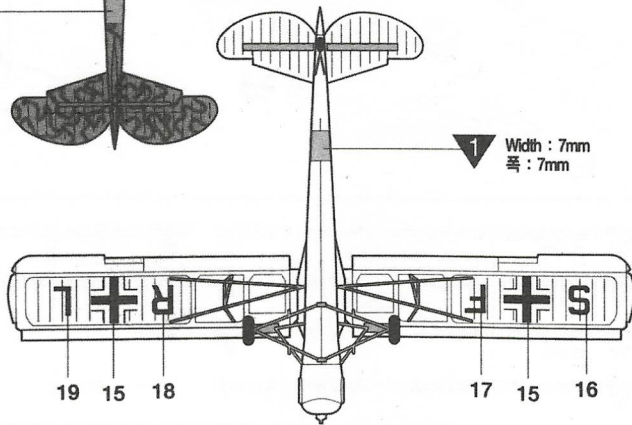

2 Eastern Front 1942



9 RLM 70



8 RLM 83



10 RLM 76

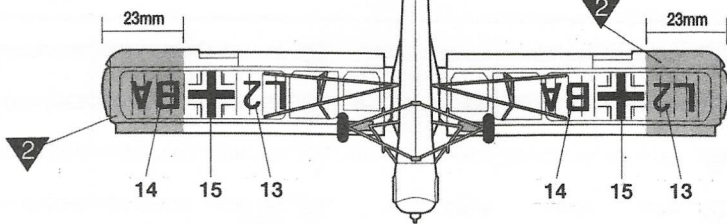
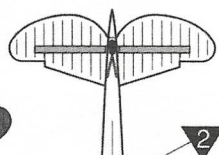
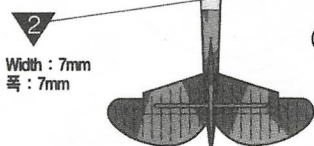
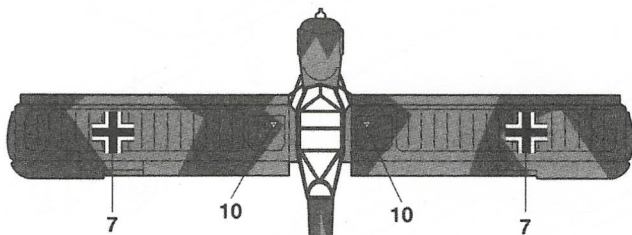
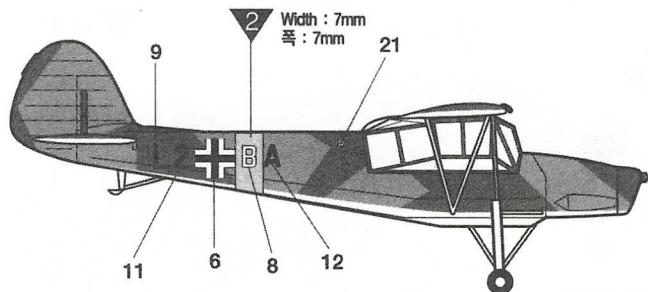
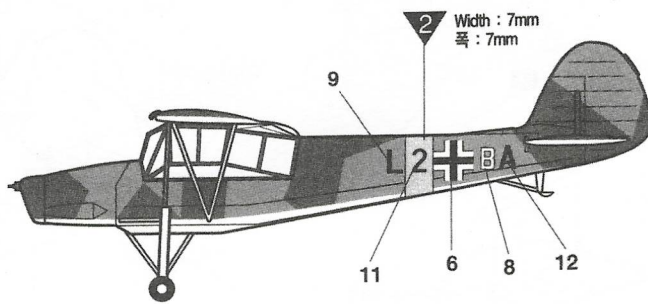

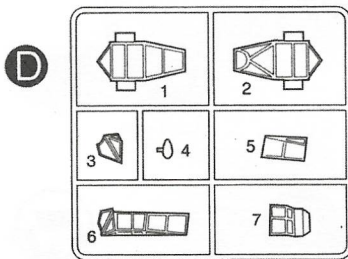
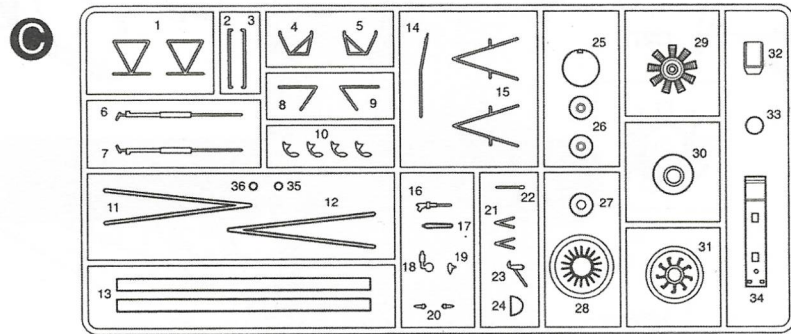
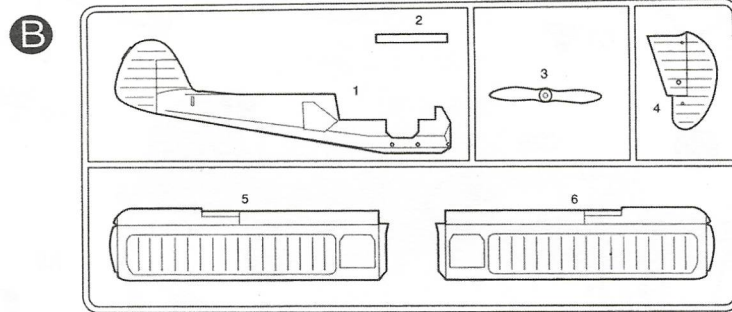
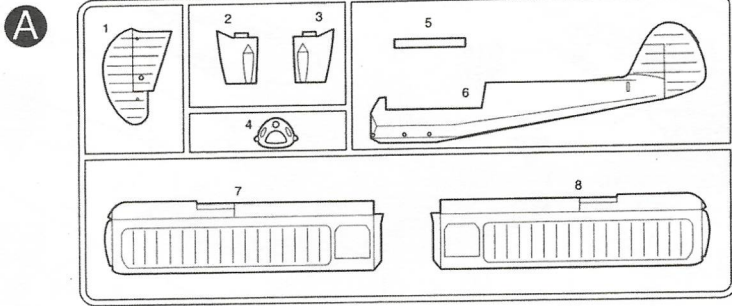

■ Unused Parts 불필요부품  
: C1×1, C21×1

**ACADEMY** **ACADEMY**  
HOBBY MODEL KITS ACADEMY PLASTIC MODEL CO., LTD.  
고객상담전화: 031-850-8555



**3** France 1947



RLM 76

