

Curtiss P-6E "Hawk"

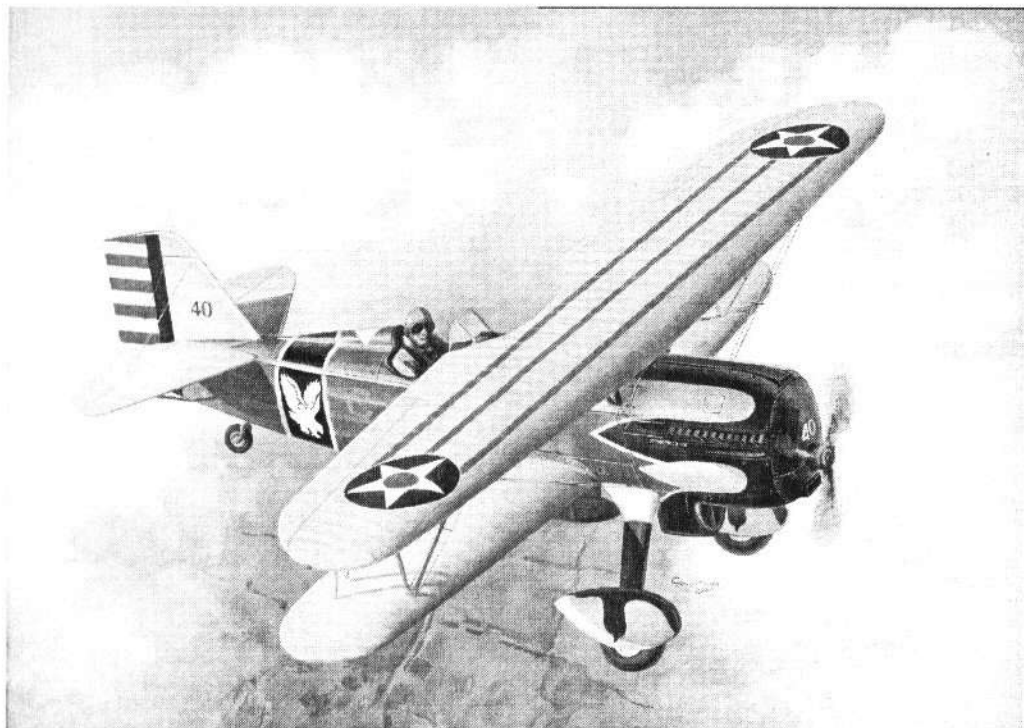

The Curtiss P-6E, a first-line pursuit aircraft of the early 1930s, was the last of the fighter biplanes built in quantity for the Army Air Corps. Originally designated the Y1P-22, it was later redesignated the P-6E because of the similarity to the other P-6 series airplanes. Although it was never used in combat, it is remembered as one of the most beautiful biplanes ever built. Despite its excellent performance, only 46 P-6Es were ordered because of the shortage of funds for the Air Corps during the austere days of the Great depression.

Das Curtiss P-6E ist amerikanisch Hauptjagdflugzeug von Anfang 30-er Jahres. Es ist Letzte Jagdflugzeug-Doppeldecker, das von Army Air Corps bestellt hat. Man hat es als Army Air Corps zuerst ausgearbeitet. Dann, wegen der Ähnlichkeit mit anderen Flugzeuge der P-6 Familie, hat man als Army Air Corps neu benennt. Dieses Flugzeugbaumuster ist als ein aus eleganter Jäger-Doppeldecker, die jemals gebaut sind, obwohl es niemals gekämpft ist. Trotz der ausgezeichneten technische Daten, wegen der Great depression, hat man nur 46 Exemplaren dieser Jäger bestellt und gebaut.

SPECIFICATION





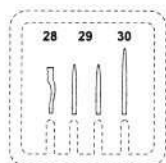
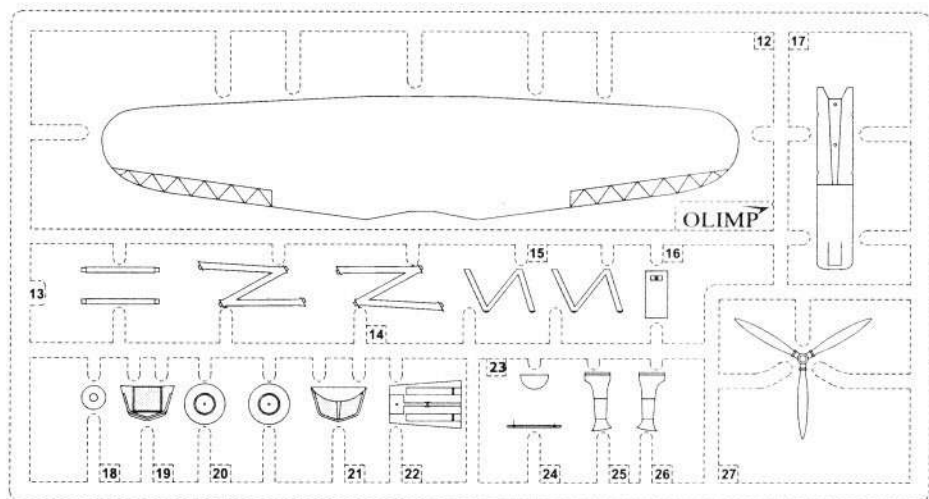
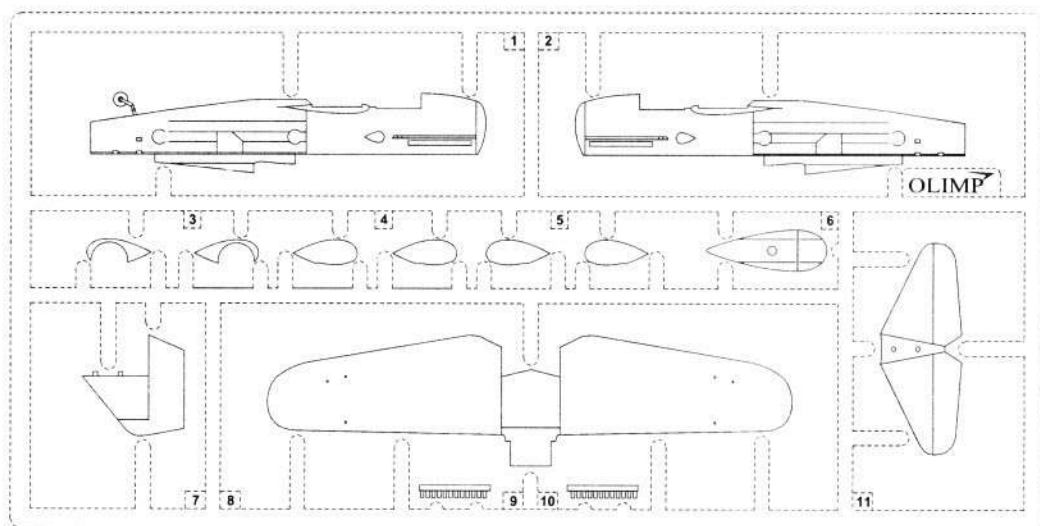

Wing Span	31 ft 6 in
Length	23 ft 2 in
Height	8 ft 11 in
Engine rating	600 h.p.
Gross weight	3 432 lbs.
Maximum Speed	204 mph
Range	480 miles
Armament	Two .30 mach. guns

Technische Daten

Spannweite	31 ft 6 in
Länge	23 ft 2 in
Höhe	8 ft 11 in
Triebwerk Leistung	600 PS
Gewichte	3 432 lbs.
Hochgeschwindigkeit	204 mph
Reichweite	480 miles
Bewaffnung	MG 7.62 mm



CONDITIONAL MARKINGS / УСЛОВНЫЕ ОБОЗНАЧЕНИЯ

- | | | | |
|---|---|---|--|
|  | Stages of the assembly
Этапы сборки |  | Possible variants
Возможны варианты |
|  | Do not glue
Не клеить |  | Symmetrical assembly
Симметричная сборка |
|  | Unused parts
Неиспользуемые детали |  | Cut knife
Разрезать ножом |
|  | Paints
Краски |  | Warm and curly
Нагреть и изогнуть |
|  | Variant of the assembly
Вариант сборки |  | Drill or pierce
Просверлить или проколоть |
|  | Use decal
Использовать декаль |  | Repeat operation
Повторить операцию |

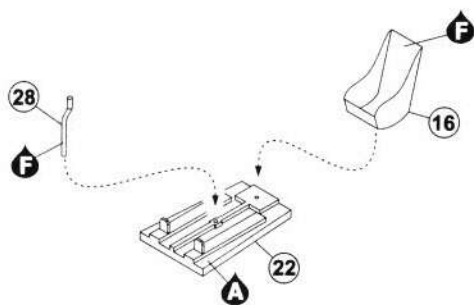
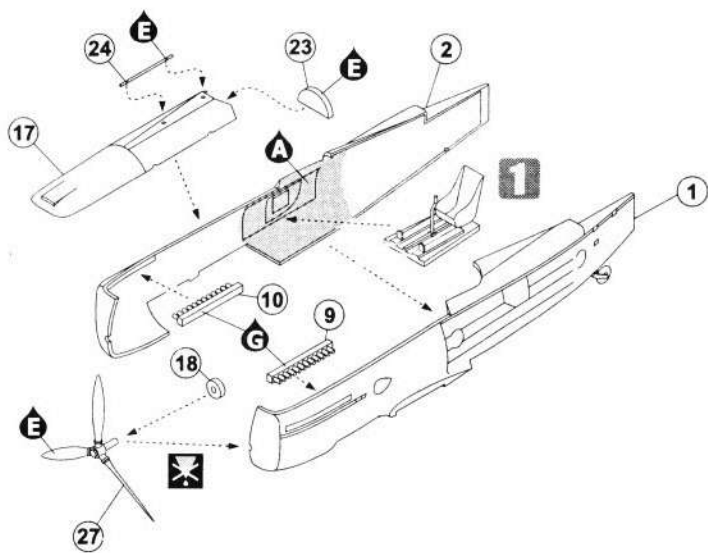
1**2**

3

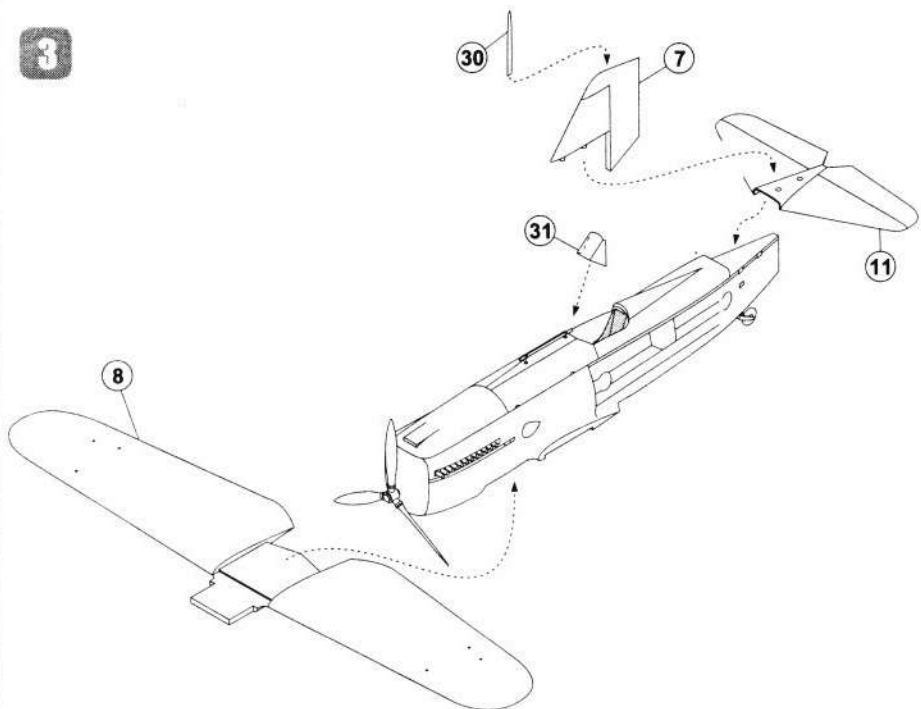

4

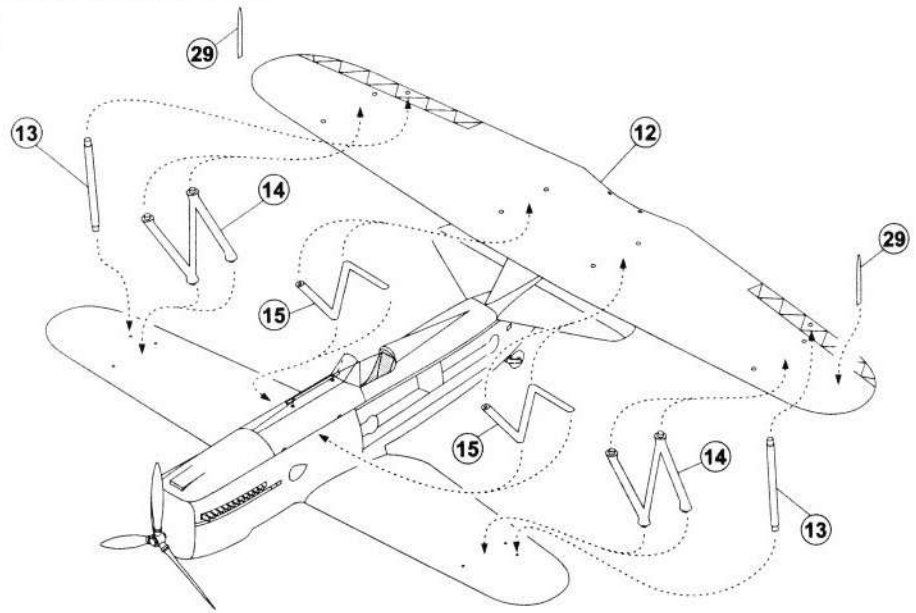

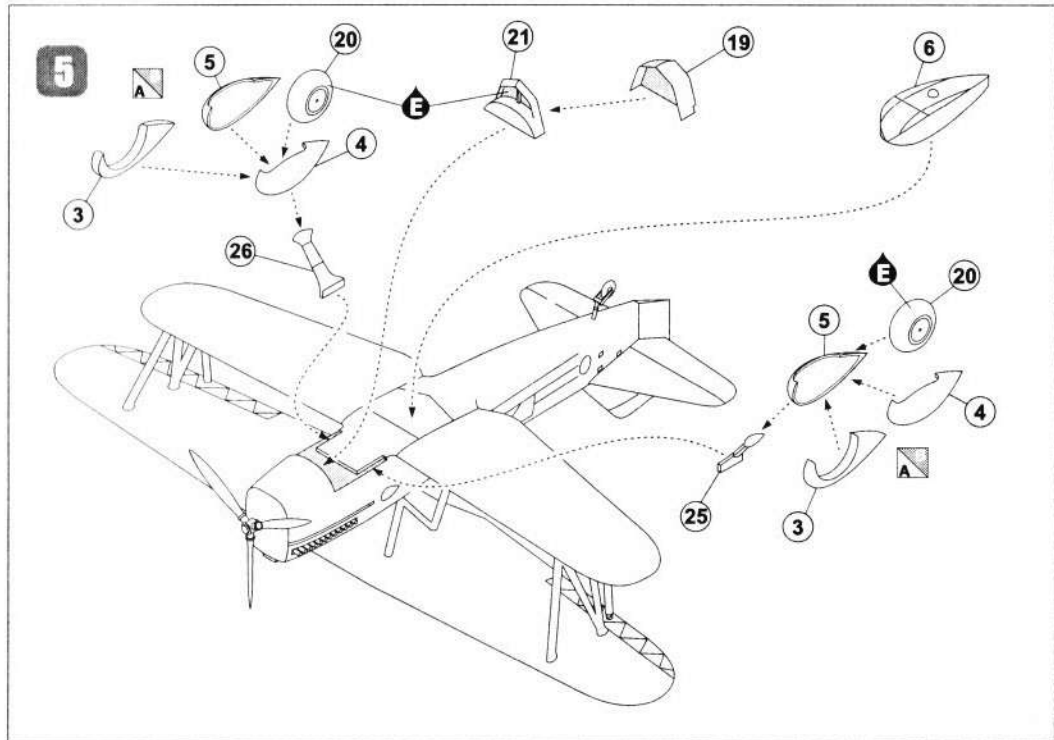

Rigging scheme

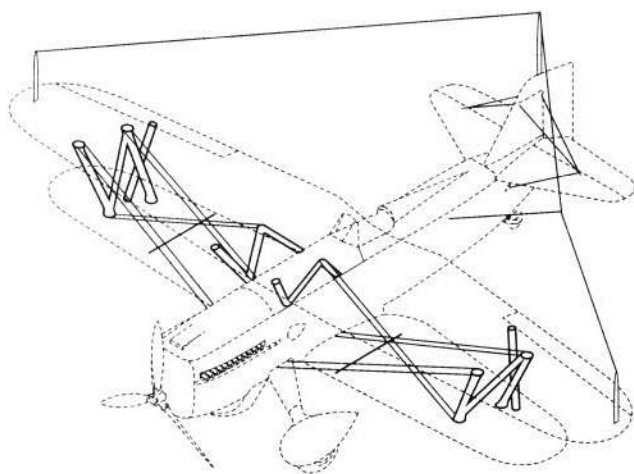

A Curtiss P-6E "Hawk"
Wright Field, Ohio, 1937

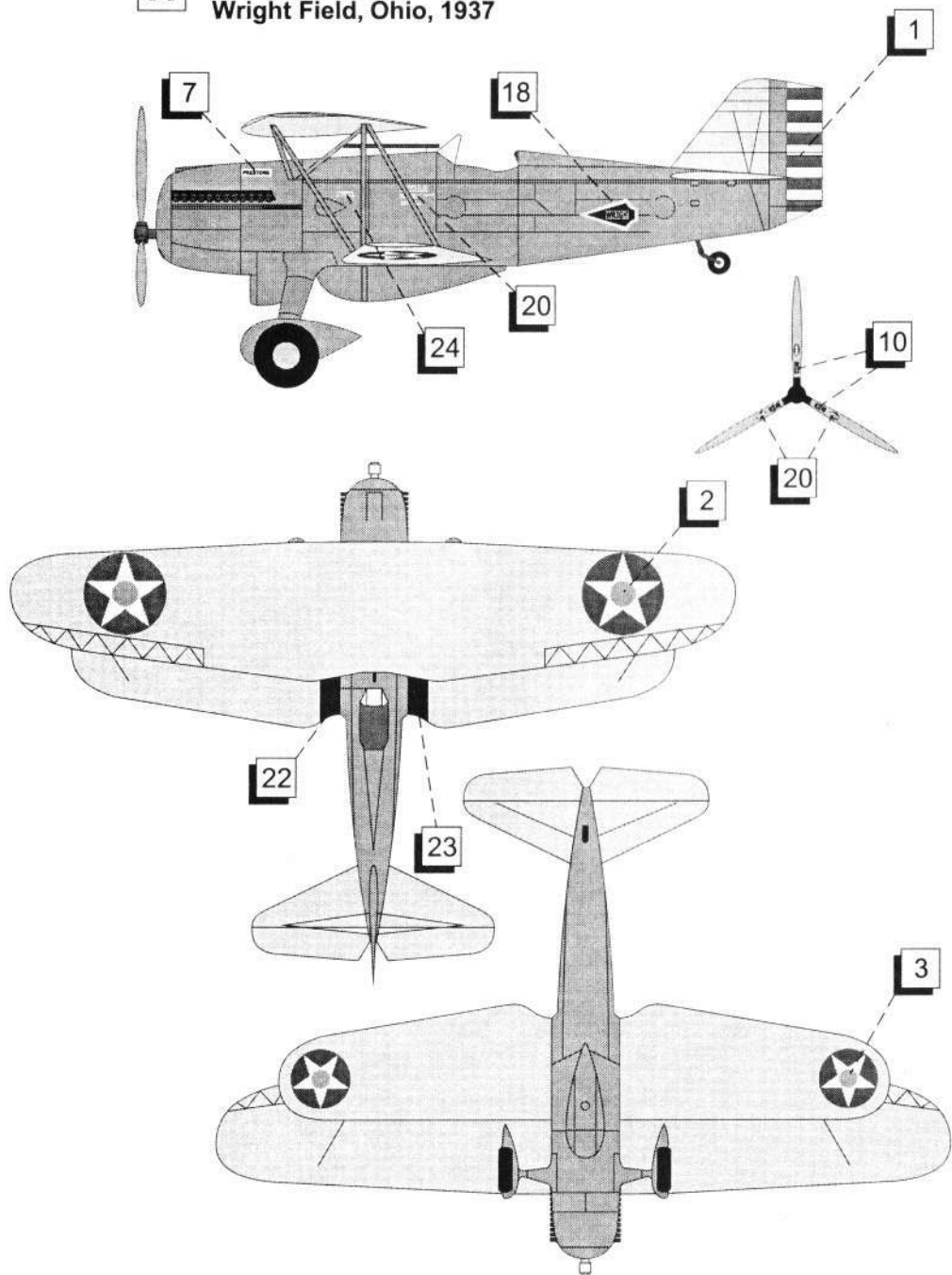

B Curtiss P-6E "Hawk"

17 Pursuit Squadron, Selfridge Field, Michigan, 1933

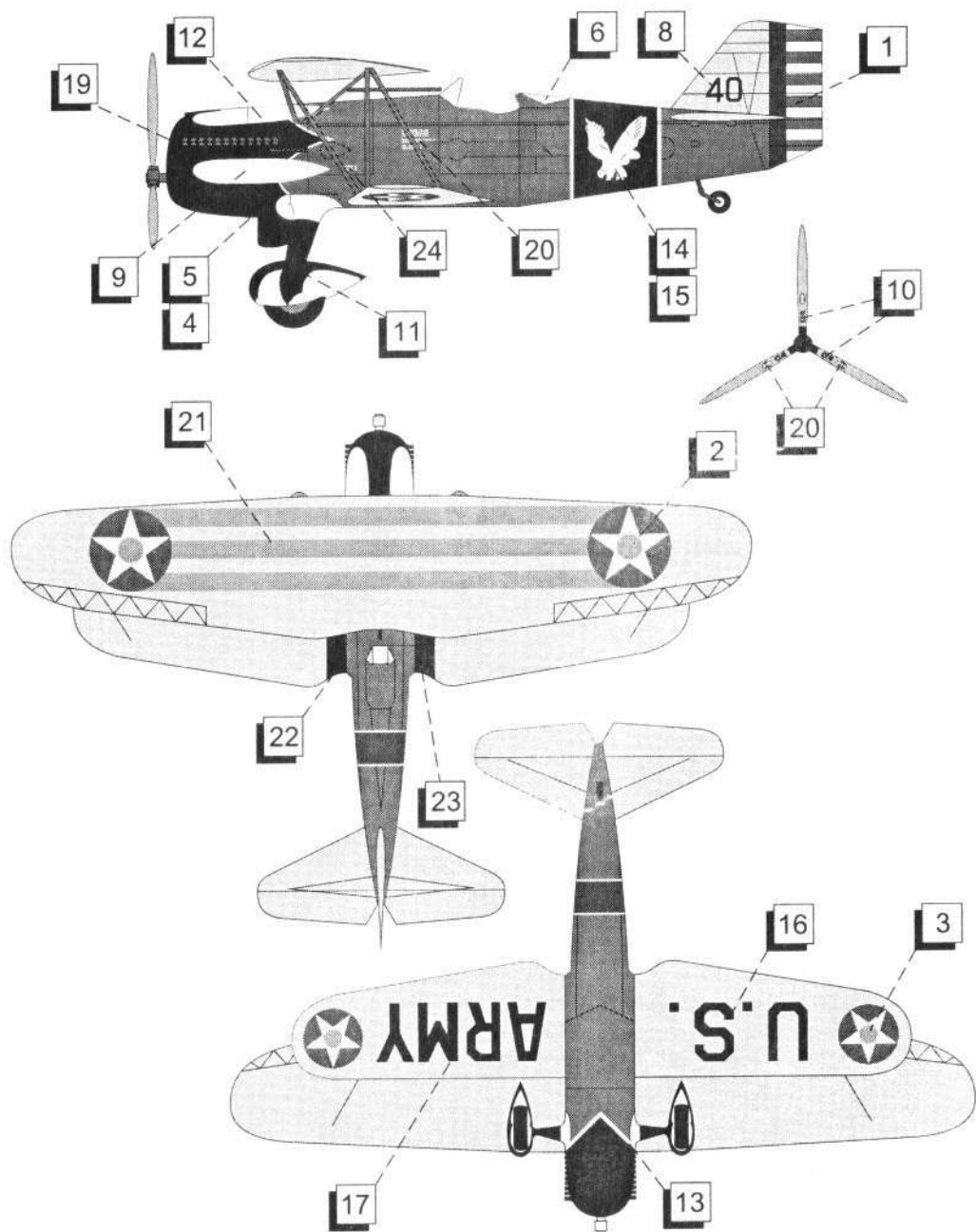

GB Contains one unassembled model kit and easy to follow pictorial instructions. Paint and cement are not included. Kit suitable for ages 10 to adult.

FR Il contient un complexe non recueilli avec une simple instruction illustrée. Les peintures et la colle ne sont pas insérés. Le complexe est destiné pour les modelists âgé plus que 10 ans.

D Die Verpackung enthält einen nicht zusammengebauten Set und eine einfache Bedienungsanleitung mit Abbildungen. Kleber und Farben sind nicht beigelegt. Dieser Set ist für alle Modellbauer ab 10 Jahren geeignet.

RUS Содержит один несобраный комплект с простой иллюстрированной инструкцией. Краски и клей не включены. Комплект предназначен для моделлистов старше 10 лет.

RECOMMENDED SOURCES / ПОЛЕЗНЫЕ ИСТОЧНИКИ

[Http://www.curtisshawkp6e.com](http://www.curtisshawkp6e.com) [Http://www.wpaafb.af.mil/museum/early_years/ey13.htm](http://www.wpaafb.af.mil/museum/early_years/ey13.htm)

1. Paul Matt Scale Aircraft Drawings, Volume 1
2. "AirWars" The Aircraft and Air Warfare of the Middle Years, No.2 June 1985
3. "Model Airplane News" Aug. 1968
4. "The Best Of Wyllam" Model Airplane News, book 2
5. "Curtiss Army Hawks" in action, No. 128, Squadron/Signal Publications, 1992

USED PAINTS

Symbol	Name	Humbrol	Model Master	Revell
A	Light Aircraft Grey	166	--	--
B	Olive Drab	155	1711	--
C	Service Brown	10	1540	81
D	Trainer Yellow	24	169	311
E	Black (matt)	33	1749	8
F	Aluminium	56	1781	99
G	Polished Steel	27003	1402	--
H	Bright Red	19	1503	31

