

Shenyang F-8II "Finback"-B

沈阳F-8II“长须鲸”-B

1:72 SCALE

READ BEFORE ASSEMBLY

- Study and understand these instructions thoroughly before beginning assembly. Make sure all parts are included by comparing them to those shown on pages 2 to 4 of these instructions.
- Remove parts from sprues as needed, and trim excess with a hobby knife. Be careful not to lose small parts.
- Remove photo-etch parts from sprue as needed using a hobby knife or photo etch cutter.
- Apply cement to photo etch parts as shown on instructions. Applying too much cement will restrict the operation of these

movable parts. Apply cement carefully! Removed photo etch parts can have sharp edges. Take care when handling these to avoid injury.

- Apply decals to necessary parts prior to assembly.
- Additional tools recommended(not included):Sprue cutter, Long nose pliers, hobby knife, file, tweezers, pin vise, scissors, cement, sandpaper, soft cloth, glue and paint.
- Keep all parts out of reach of children, as they pose a choking hazard.
- Discard all unnecessary bags and sprues when model is completed to avoid accidental injury.

装配之前仔细阅读

- 小心用模型锉刀锉平所有零件表面的注射浇口。
- 小心用刀片切下蚀刻片零件，不要遗失小零件。
- 用强力快干胶水粘合蚀刻片零件和金属轴。过量的快干胶水使用可能导致可动零件会粘住，小心涂胶。
- 取蚀刻片时应特别注意安全，防止利边划伤手指。
- 某些零件表面需贴水上贴纸，请选择在装配的同时进行。
- 推荐模型工具(自备)：胶水，水口剪刀，长咀钳，刀片，锉刀，镊子钳，钻，剪刀，瞬间快干胶。
- 软布同砂纸同时也应该是必备工具。
- 请使用塑料胶水和油漆，模型内不含。
- 谨防小孩吸吮塑料零件，或者将塑料袋套在头上，制作时应将套材远离小孩接触。

水贴纸的使用:

1. 从水贴纸上剪下印花;
2. 将印花放入温水中浸10秒, 然后放在干净布上。
3. 拿着印花纸板将印花移到模型上;
4. 手指蘸水将印花移到适当的位置;
5. 用软布轻压印花直至水干, 气泡消失。

DECAL APPLICATION

1. Cut off decal from sheet.
2. Dip the decal in tepid water 40°C for about 10 sec. and place on a clean cloth.
3. Hold the backing sheet edge and slide decal onto the model.
4. Move decal into position by wetting decal with finger.
5. Press decal gently down with a soft cloth until excess water and air bubbles are gone.



cyanoacrylate glue
使用强力胶



weight
配重



make hole
钻孔



cut / remove
切除



option
选择



no cement
不涂胶水



decal
贴纸



bend
弯曲



file / sand
锉平

部品图
Parts

A

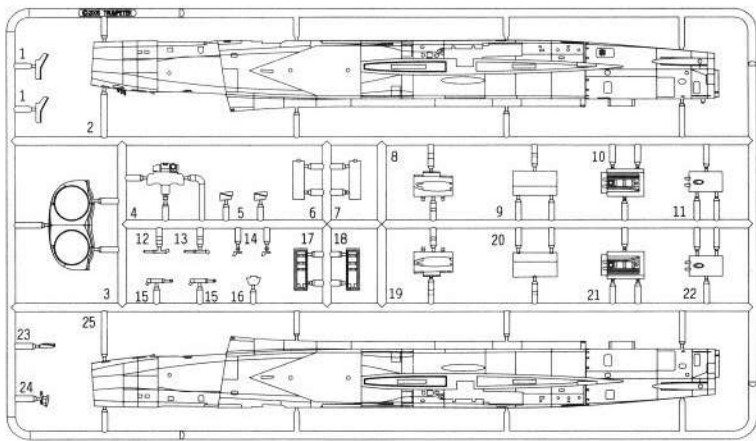

B

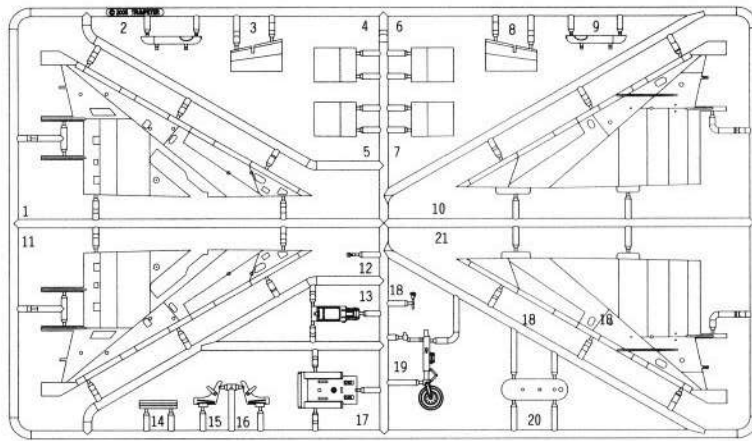

E

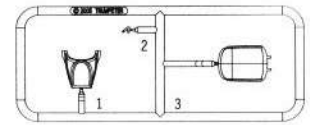

C

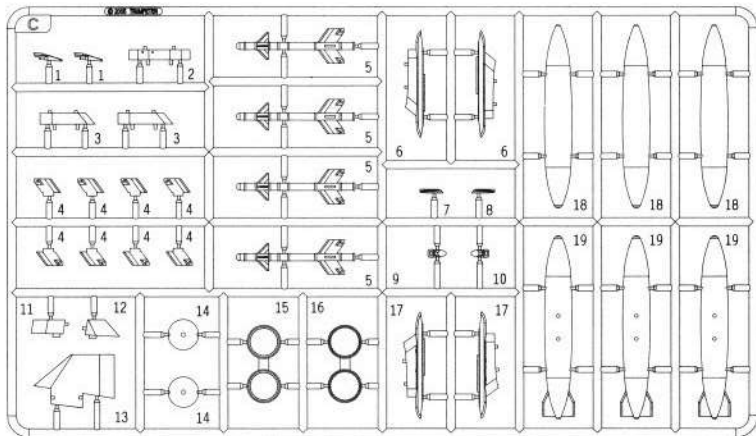

D

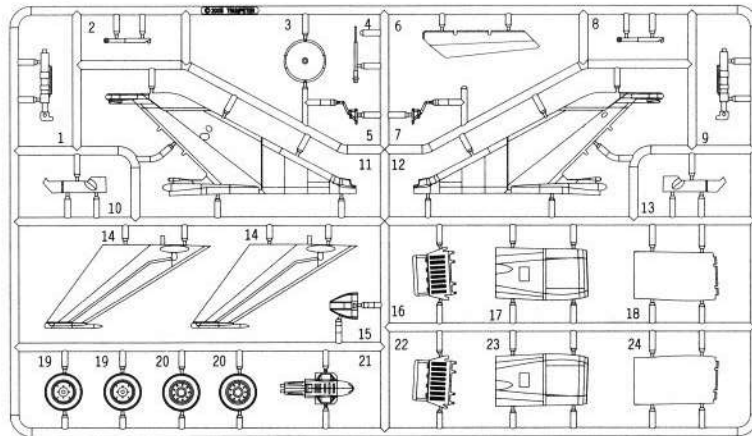

水贴纸
Decal

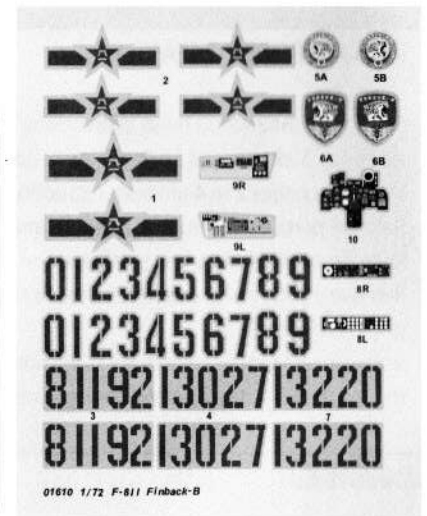

1 座舱的组装
Cockpit assembly

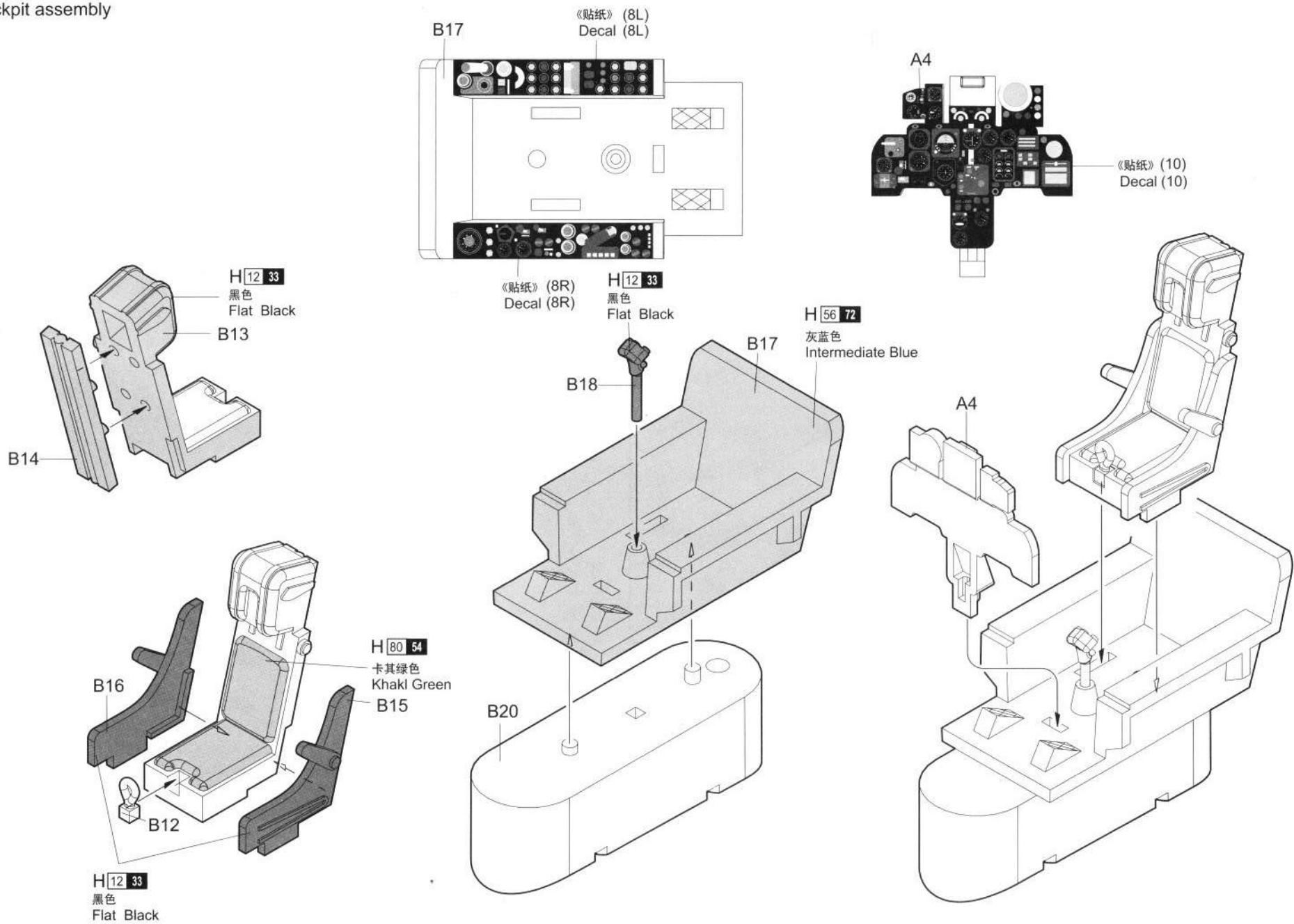

2 左侧机身的组装
Left fuselage assembly

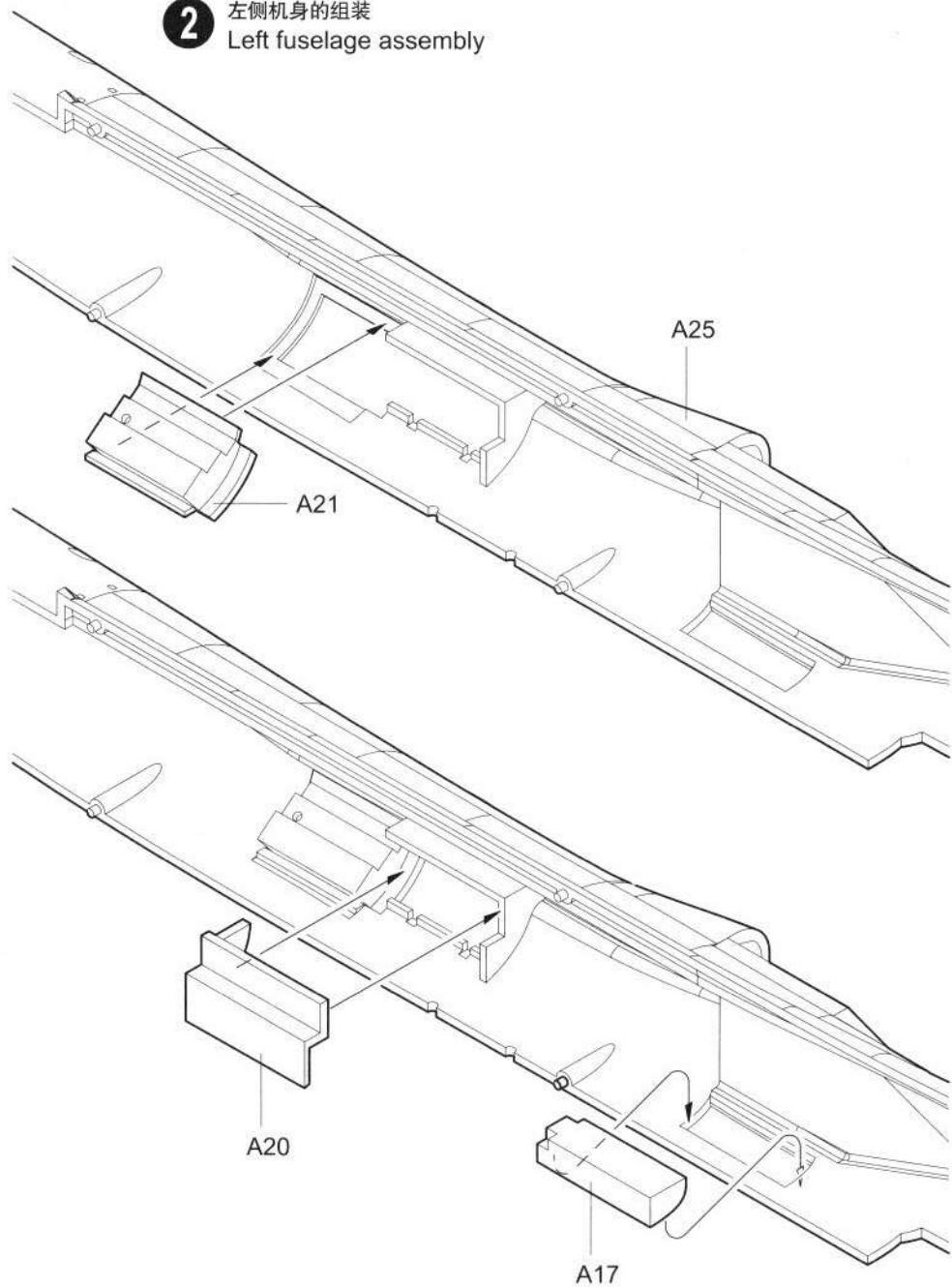

3 右侧机身的组装
Right fuselage assembly

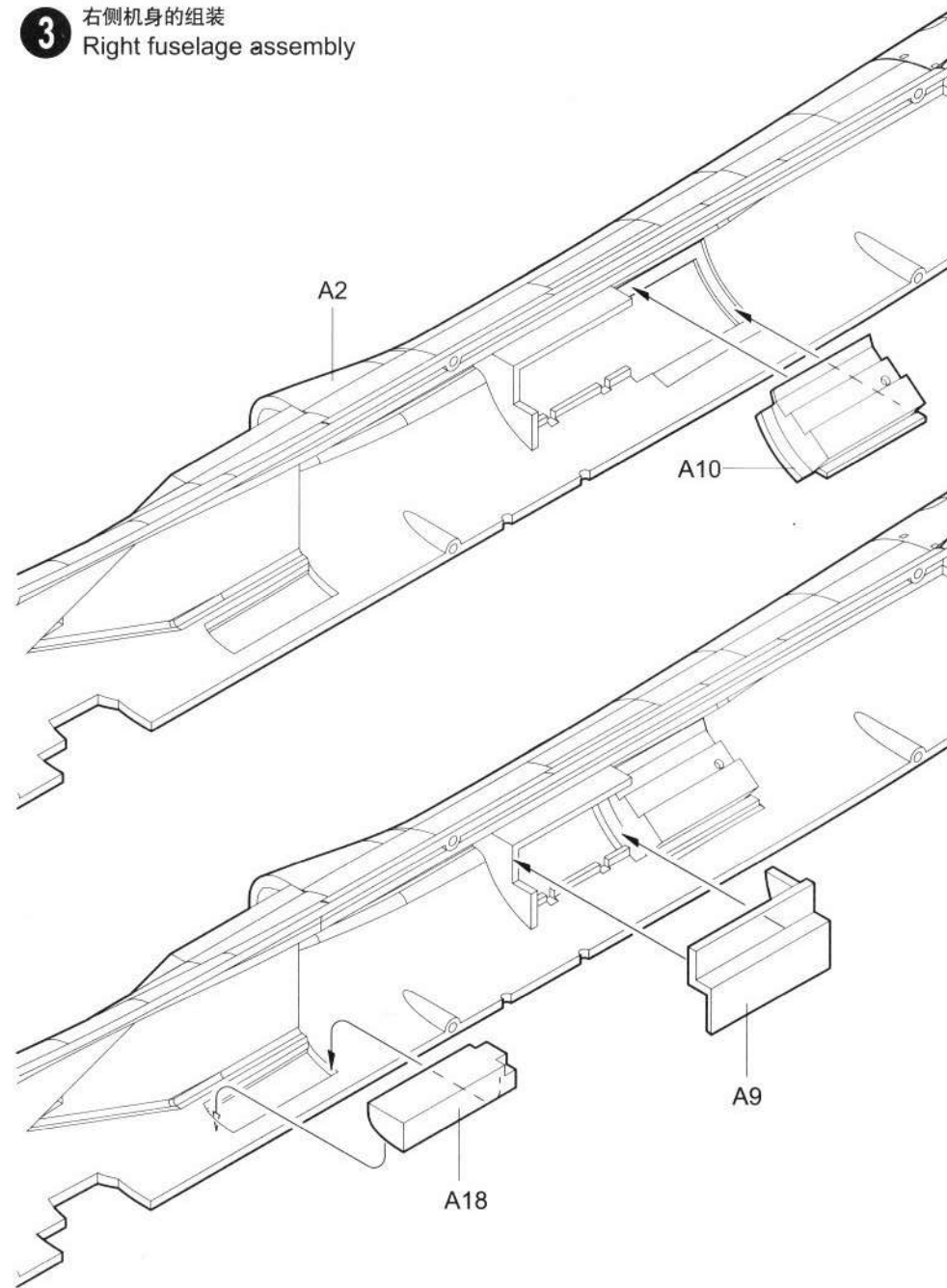

4 机身的组装
Fuselage assembly

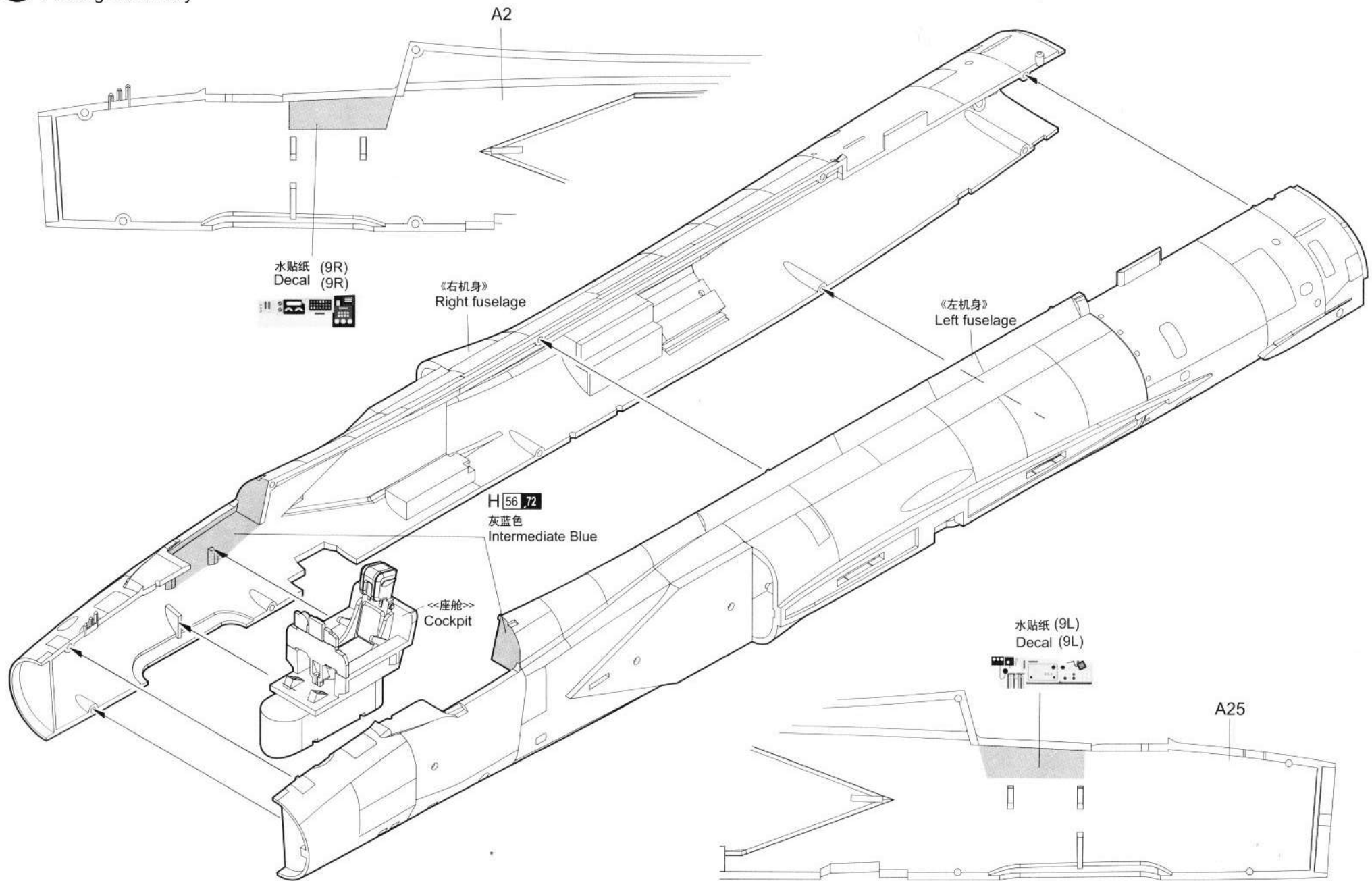

5 尾喷管的安装
Tail spout installation

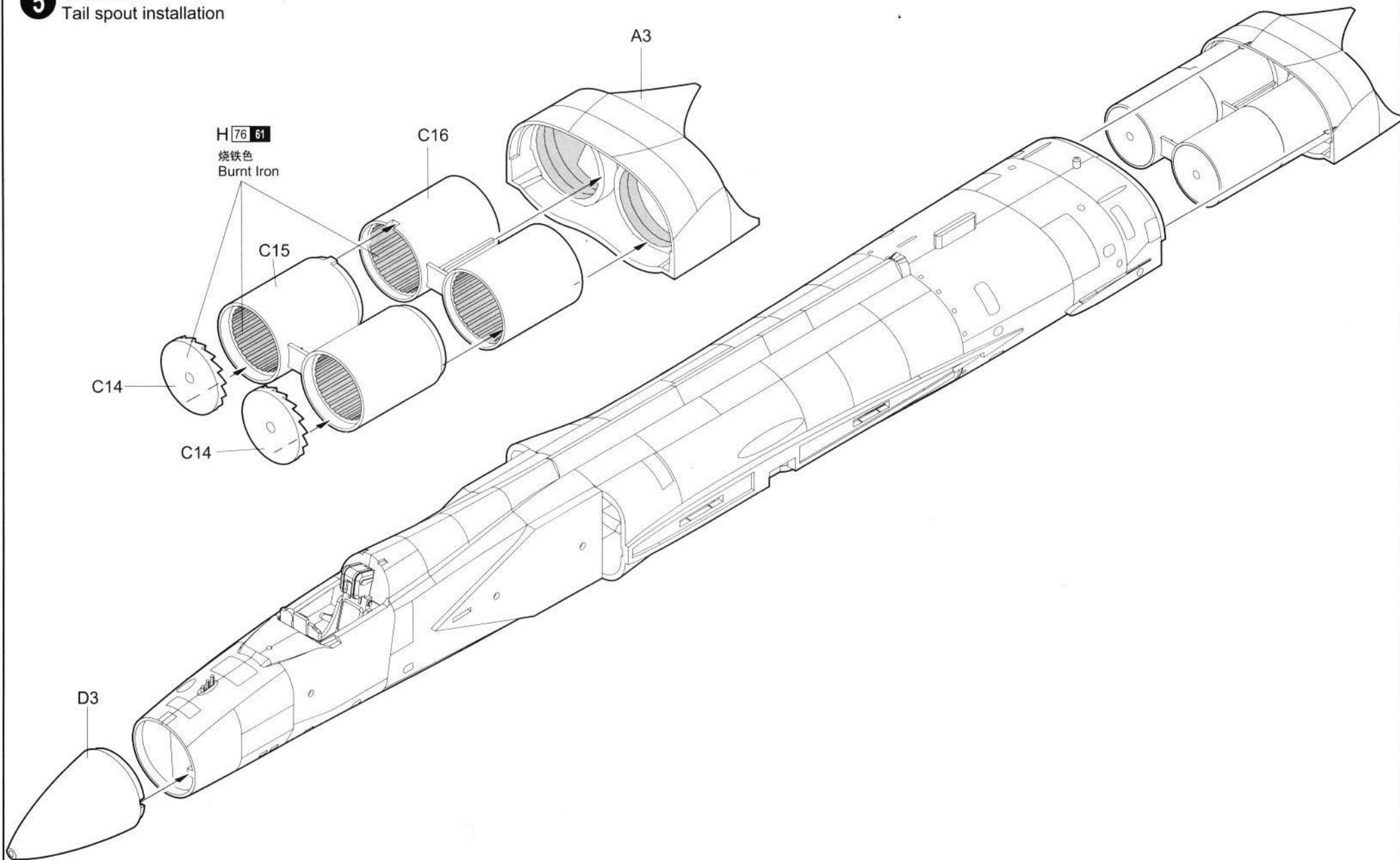

6 左侧主起落架的组装
Left main undercarriage assembly

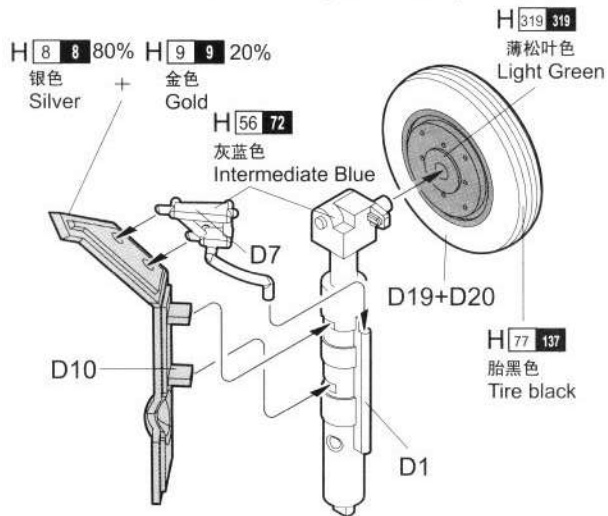

7 右侧主起落架的组装
Right main undercarriage assembly

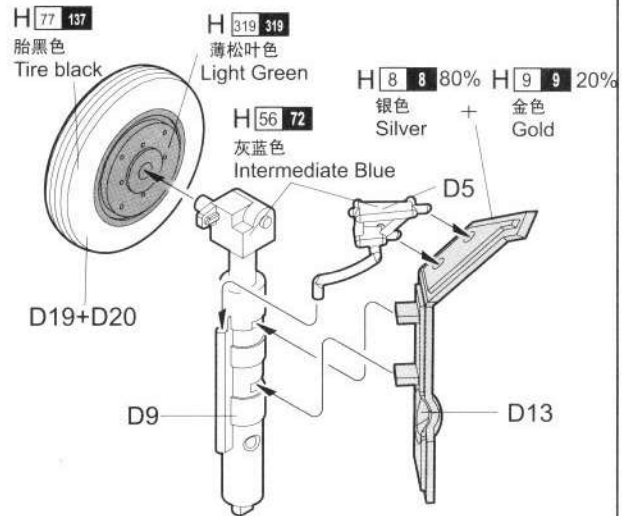

8 前起落架的安装
Nose undercarriage installation

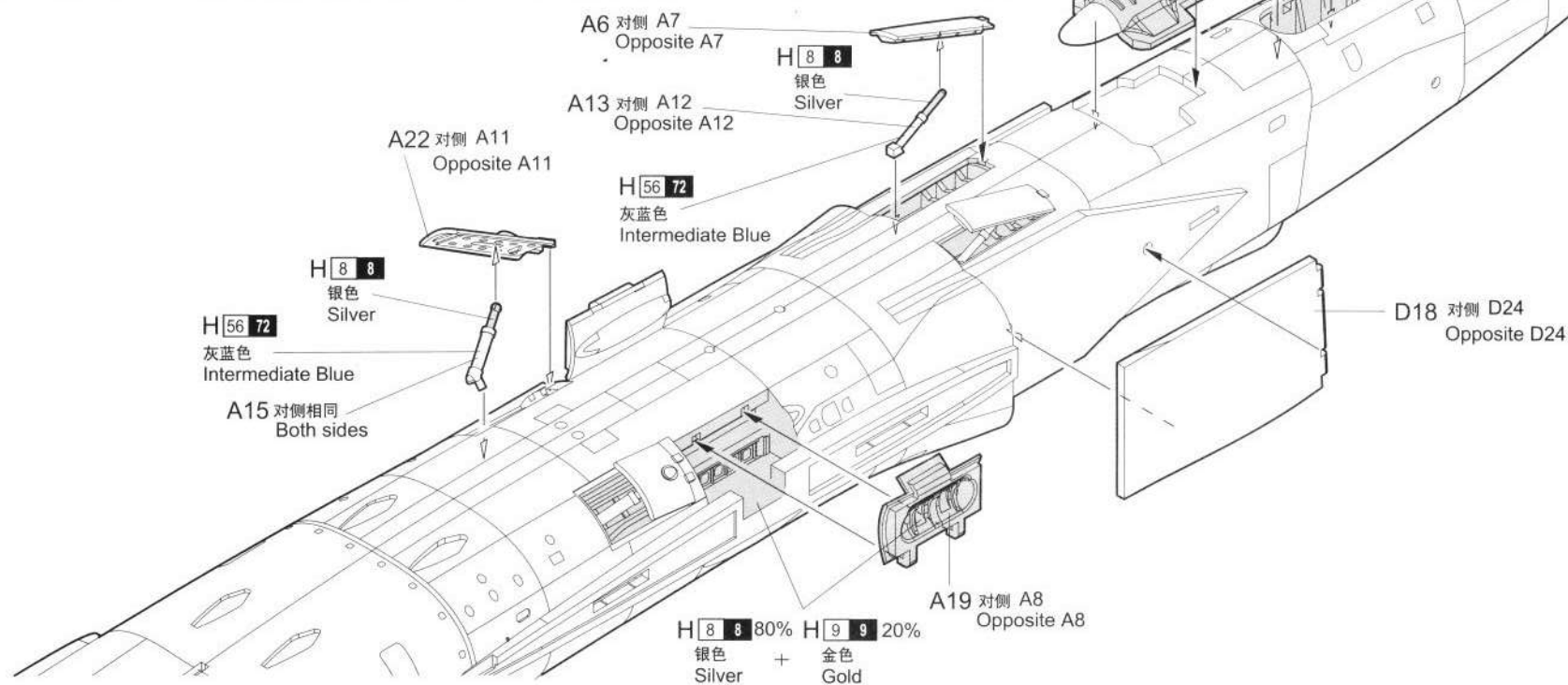
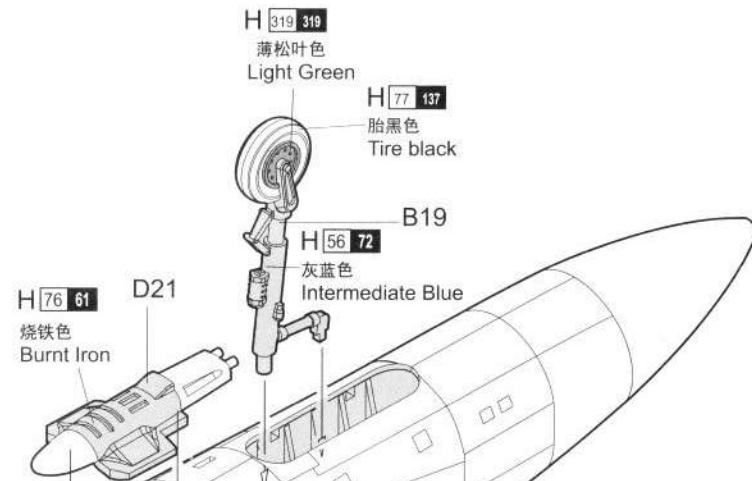

10 PL-8空对空导弹的组装
PL-8AAM assembly

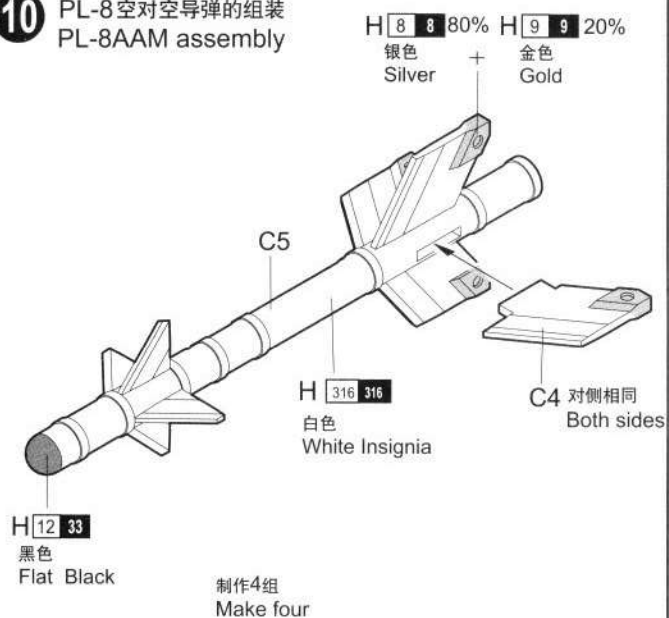

11 内侧PL-8空对空导弹的组装
Inner PL-8AAM assembly

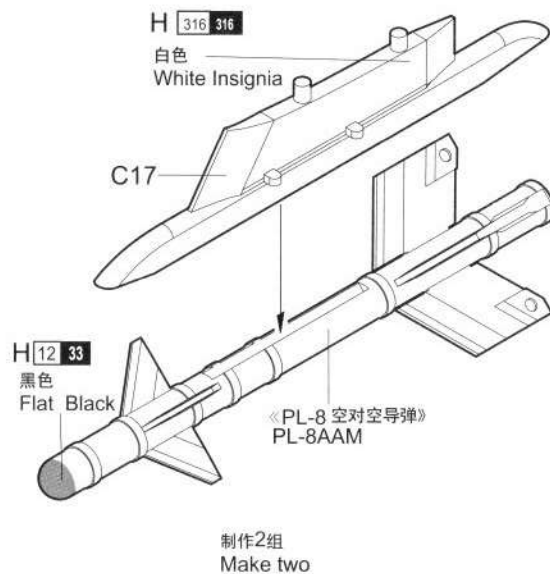

12 外侧PL-8空对空导弹的组装
Outer PL-8AAM assembly

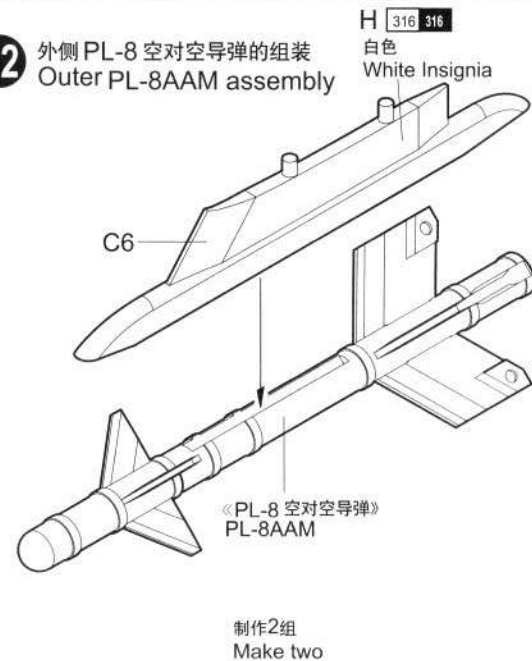

13 油箱的组装
Fuel tank assembly

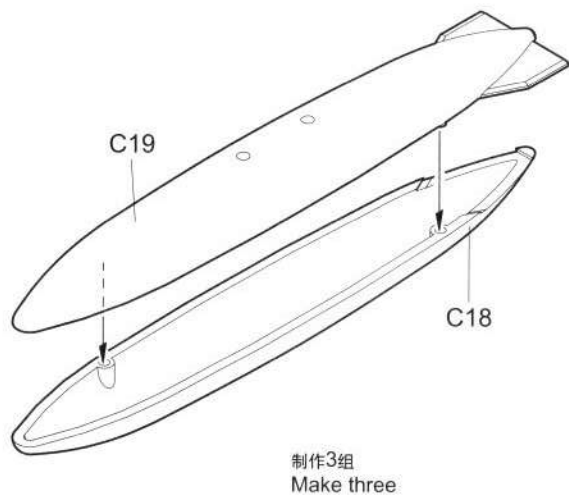

14 中心油箱的组装
Centerline fuel tank assembly

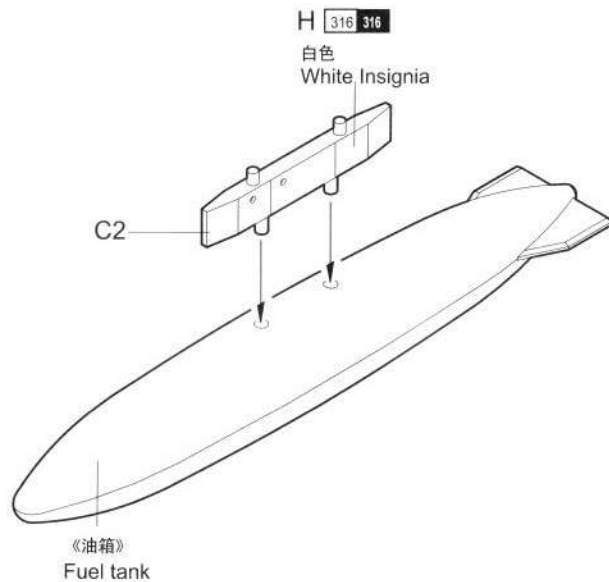

15 外侧油箱的组装
Outer fuel tank assembly

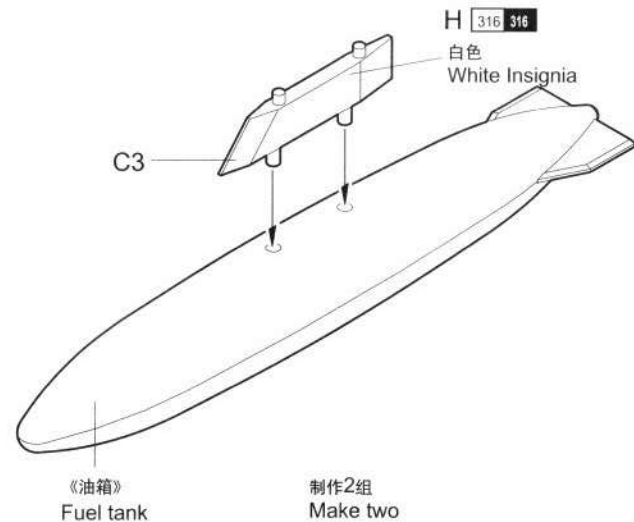

9 机腹油箱的安装
Centerline fuel tank installation

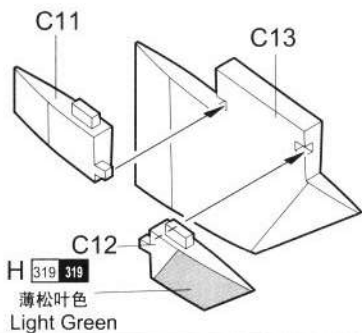
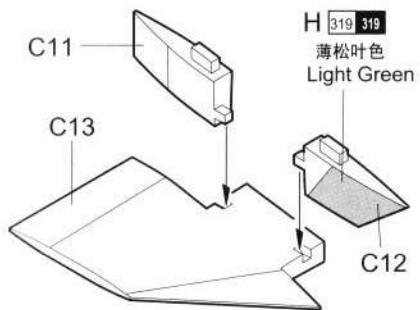

<<中心油箱>>
Centerline fuel tank

H 8 8 80% H 9 9 20%
银色 + 金色
Silver + Gold

B2 对侧 B9
Opposite B9

A16

D22 对侧 D16
Opposite D16

C10 对侧 C9
Opposite C9

C1 对侧相同
Both sides

A5 对侧相同
Both sides

A1 对侧相同
Both sides

②
可选择安装
option

D4

H 8 8
银色
Silver

E2

D17 对侧 D23
Opposite D23

H 12 33
黑色
Flat Black

D15

16 左侧机翼的组装
Left wing assembly

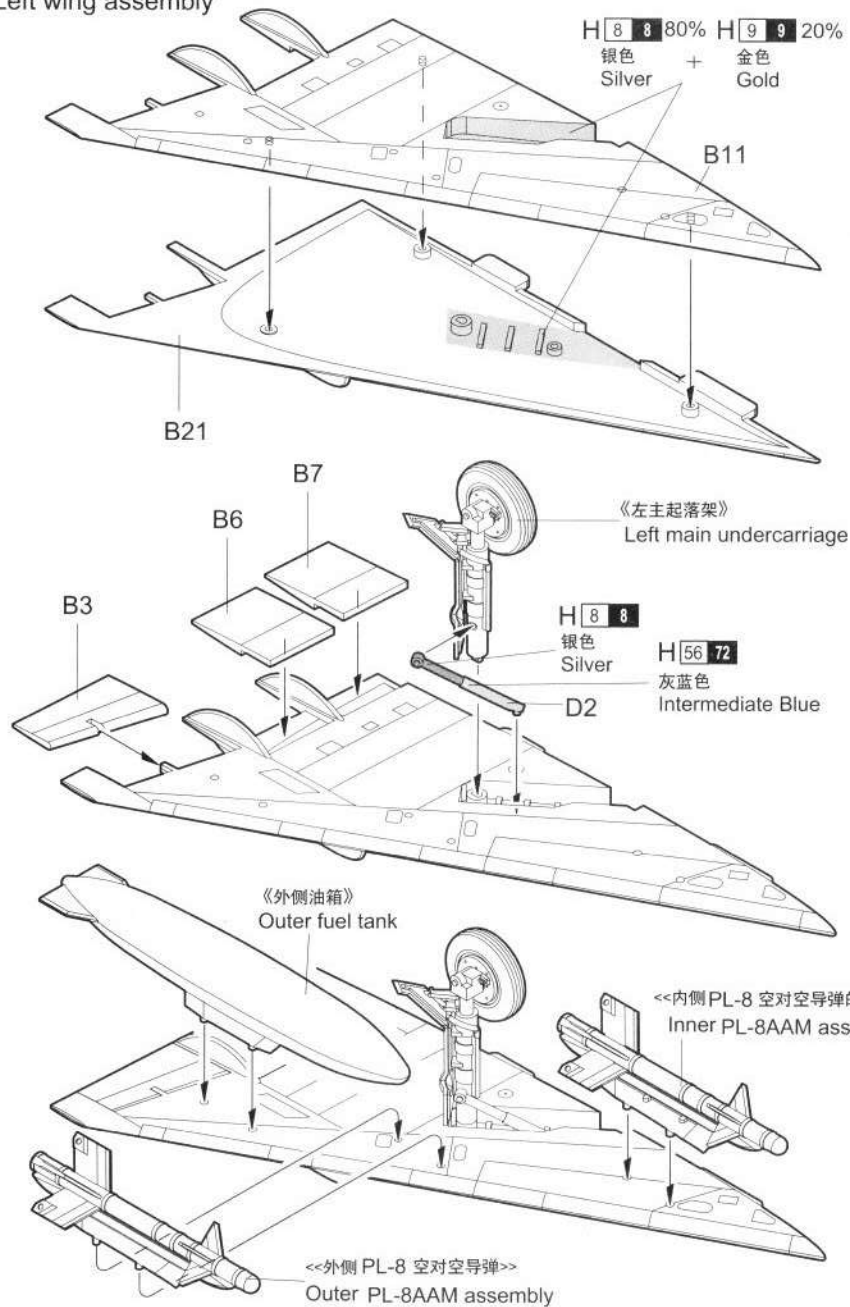

17 右侧机翼的组装
Right wing assembly

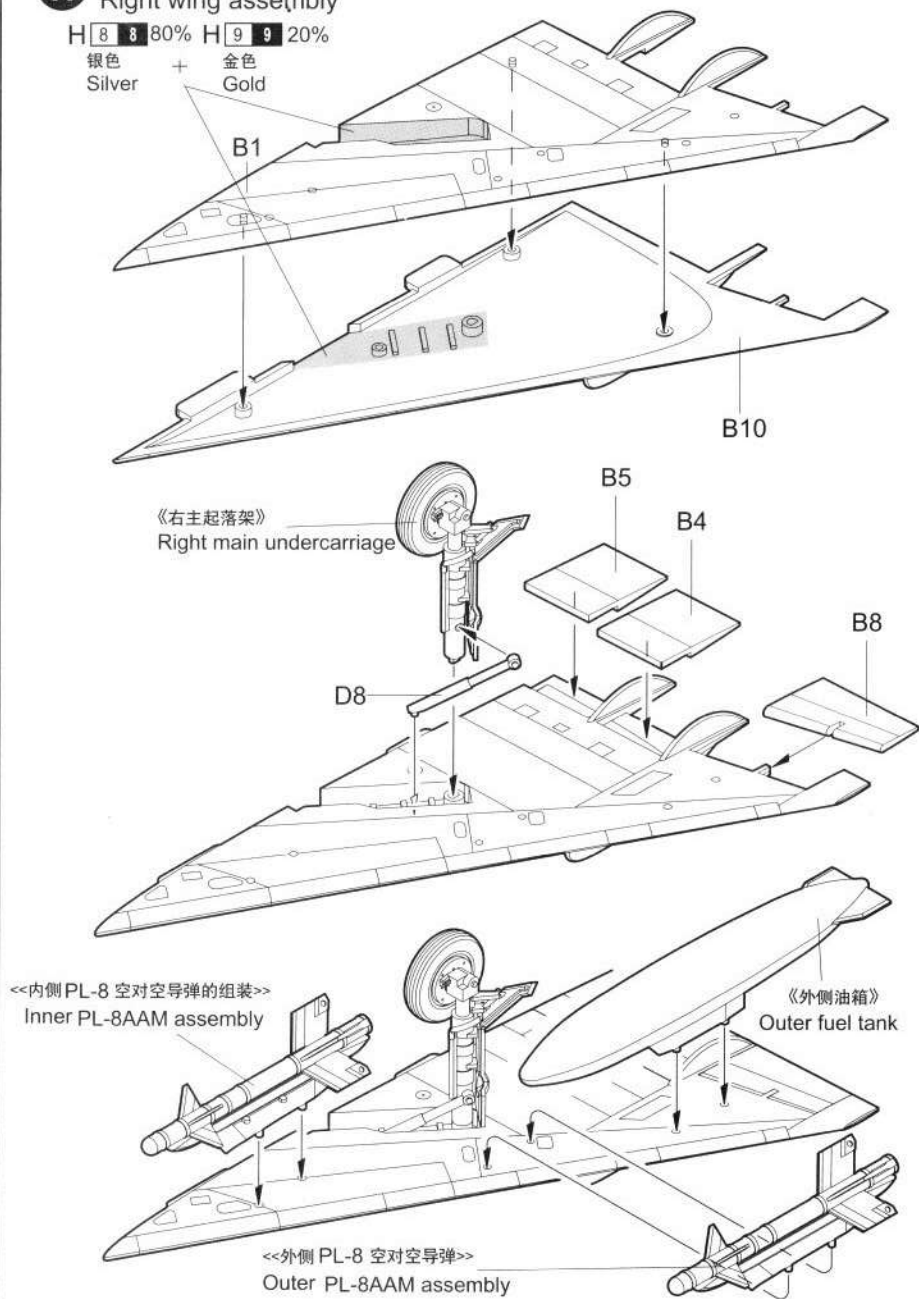

18 垂尾的组装
Vertical stabilizer assembly

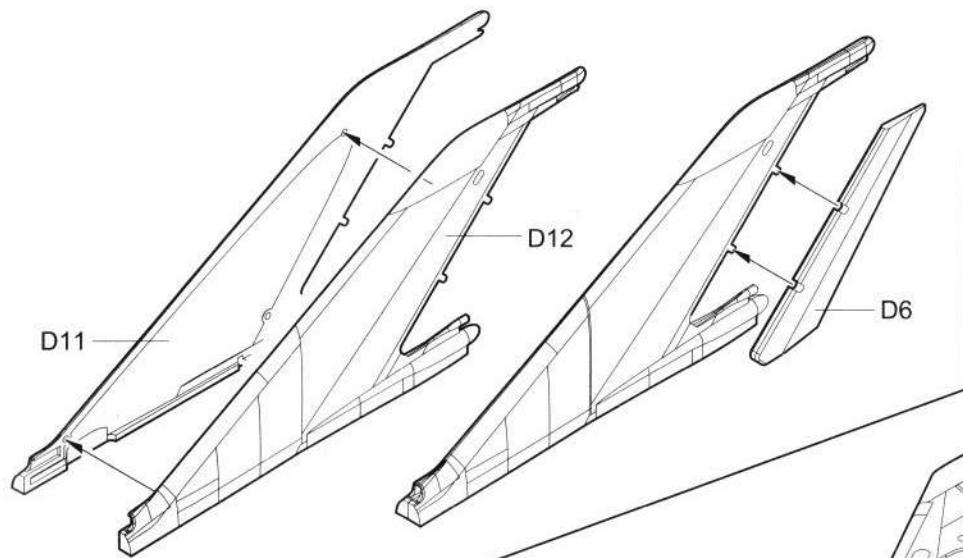

19 垂尾的安装
Vertical stabilizer installation

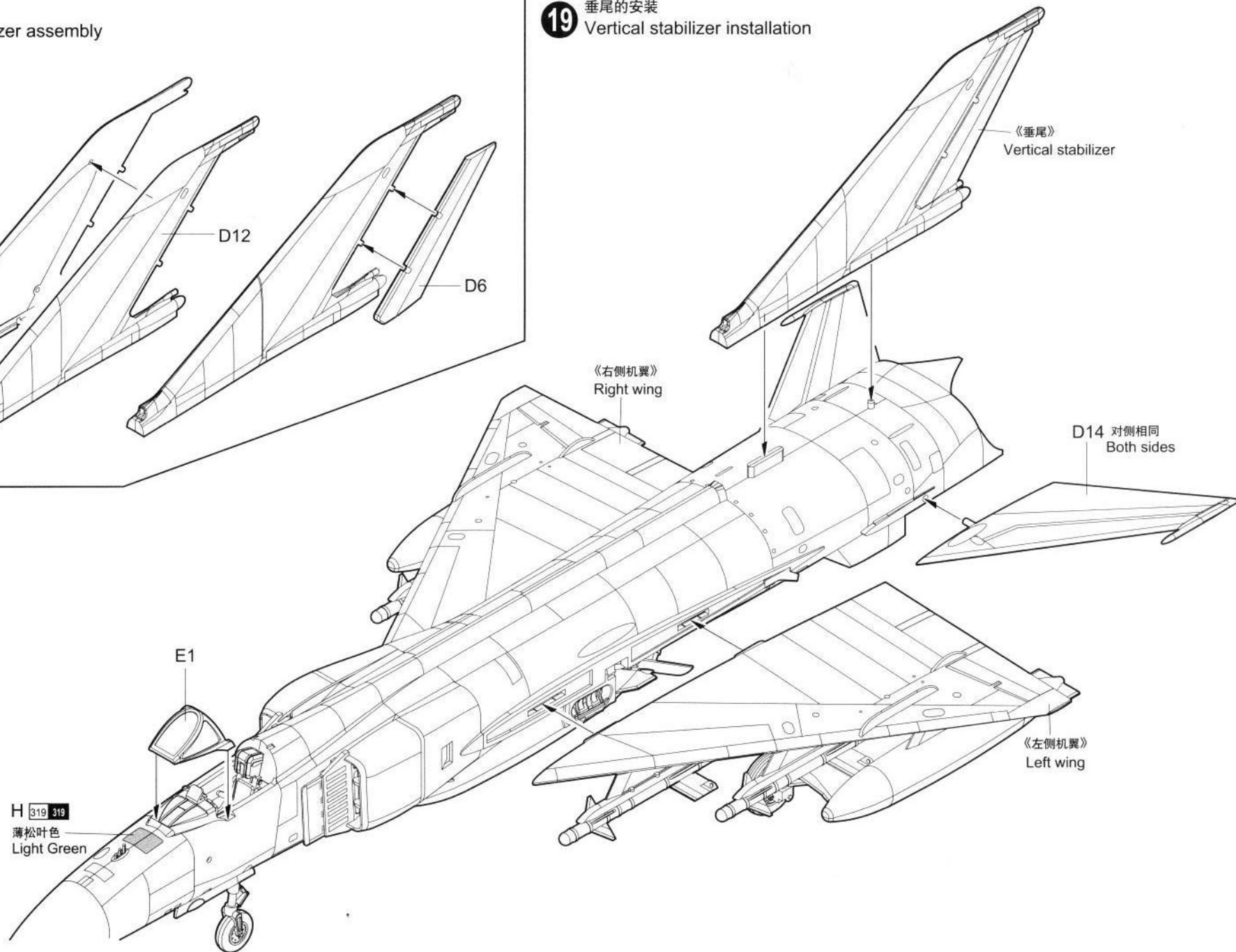

20 座舱盖的安装
Canopy installation

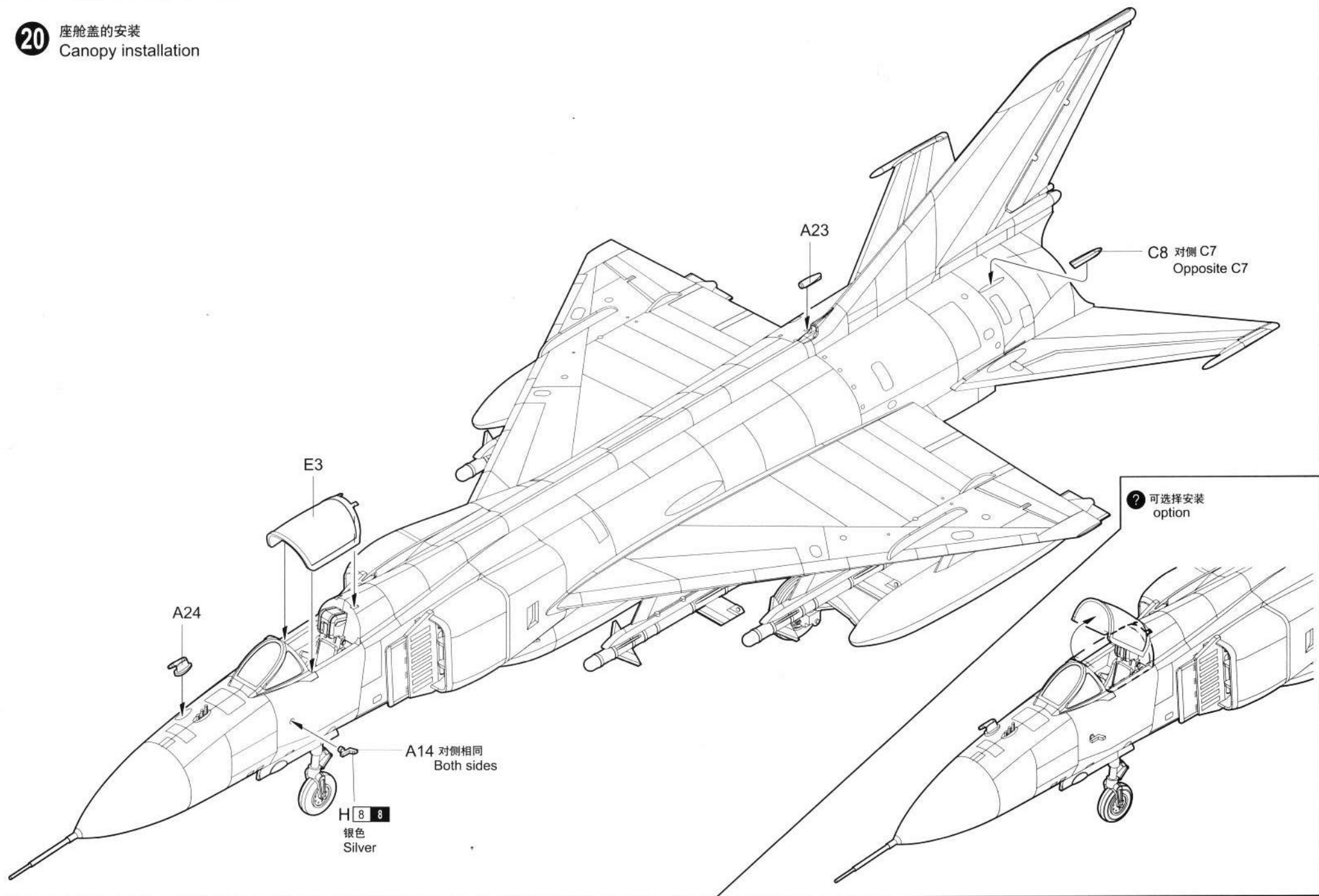

涂装同标贴指示 Painting & Marking guide

使用郡仕公司涂料
GUNZE SANGYO Mr.Color used

Gunze		
H 8 8	银色	Silver
H 76 61	烧铁色	Burnt Iron
H 18 28	黑铁色	Steel
H 74	浅灰蓝	
H 316 316	白色	White Insignia
H 319 319	薄松叶色	Light Green



H 8 GUNZE SANGYO AQUEOUS HOBBY COLOUR

8 GUNZE SANGYO MR.COLOUR



2



1



9R



9L



5A



5B



6A



6B



10

0123456789



8R

0123456789



8L

811921302713220

3

4

7

811921302713220