

Supermarine Spitfire MK IX C

Plastic model

scale :1/72

The Supermarine Spitfire was a British single-seat fighter aircraft that was used by the Royal Air Force and many other Allied countries throughout the Second World War. The Spitfire continued to be used as a front line fighter and in secondary roles into the 1950s. It was produced in greater numbers than any other British aircraft and was the only British fighter in production throughout the war. Mk IXs of all types used the standard "c" wing, which could carry four 20mm cannon or two 20mm cannon and four .303in machine guns. From 1944 some were built with the "e" wing, which replaced the four .303in machine guns with two .50in heavy machine guns. There were three main versions of the Mk IX. The standard F.IX used the Merlin 61, and was the only version produced until early 1943 1,255 F.Mk IXs were produced. It was then joined by a version powered by the Merlin 66. This engine produced its best performance at slightly lower altitudes than the Merlin 61. Spitfires equipped with this engine were designated LF Mk IX. This was the most numerous version of the Mk IX, with 4,010 produced. Finally, 410 high altitude HF.Mk IXs were produced using the Merlin 70 engine, with an improved performance at high altitude.

We would like to express our thanks to Mr. Edgar Brooks for his help with the kit.

Plastic part

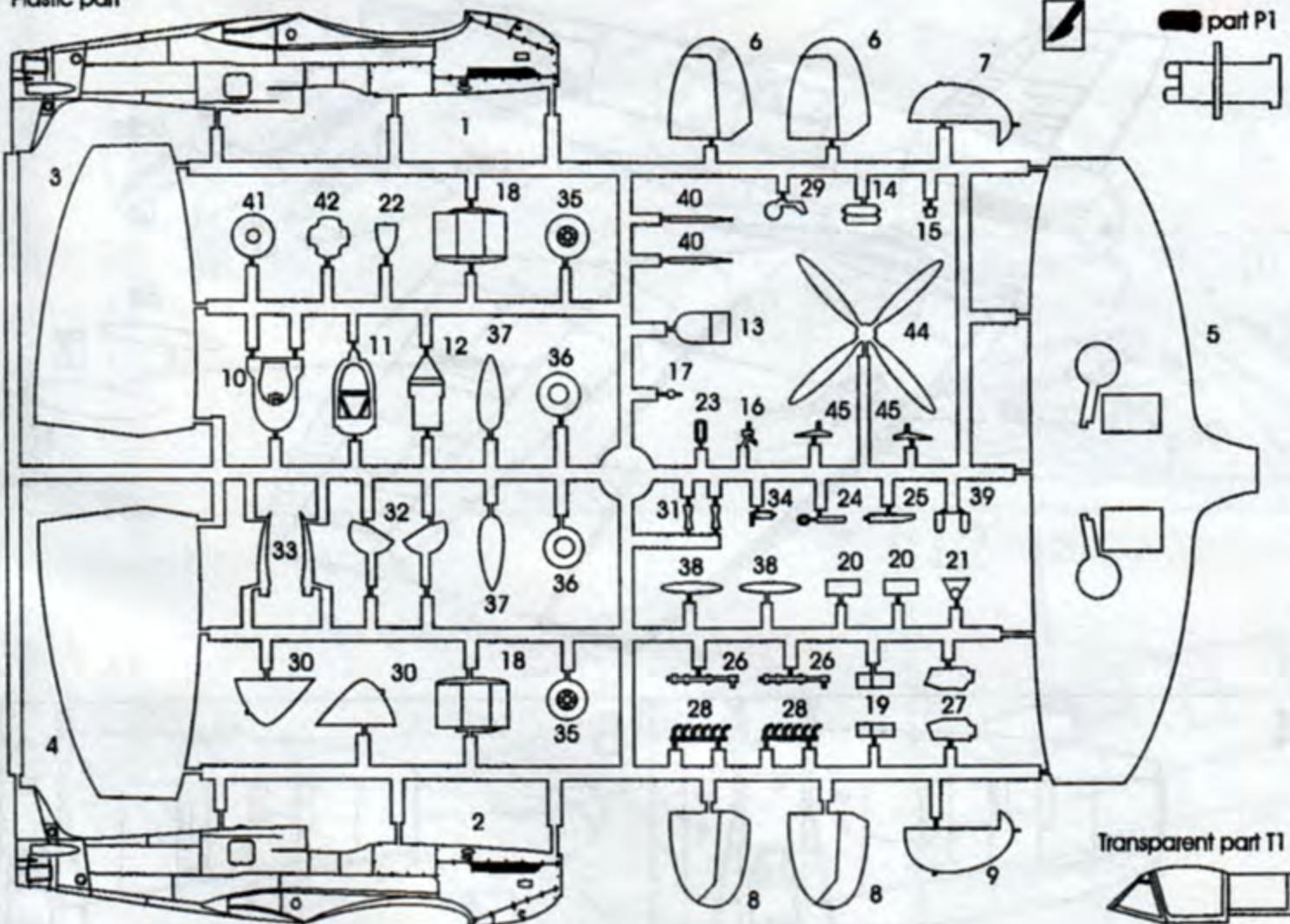

HUMBROL

	Colour name			Colour name	
A	Black	H 33	F	Desert Yellow	H 94
B	White	H34	G	Aluminium	H 56
C	Interior Green	H76	H	Brown	H 29
D	Light Grey	H64			
E	Dark Grey	H27			

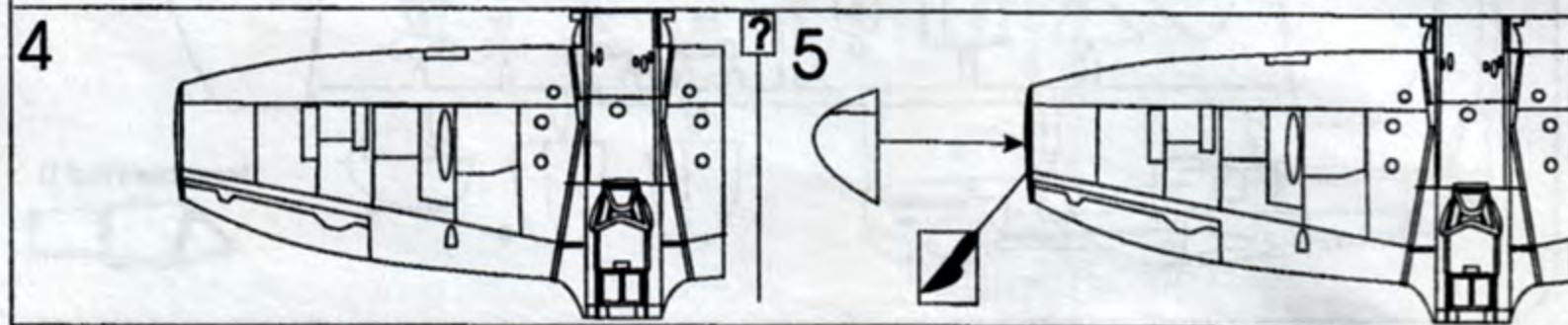
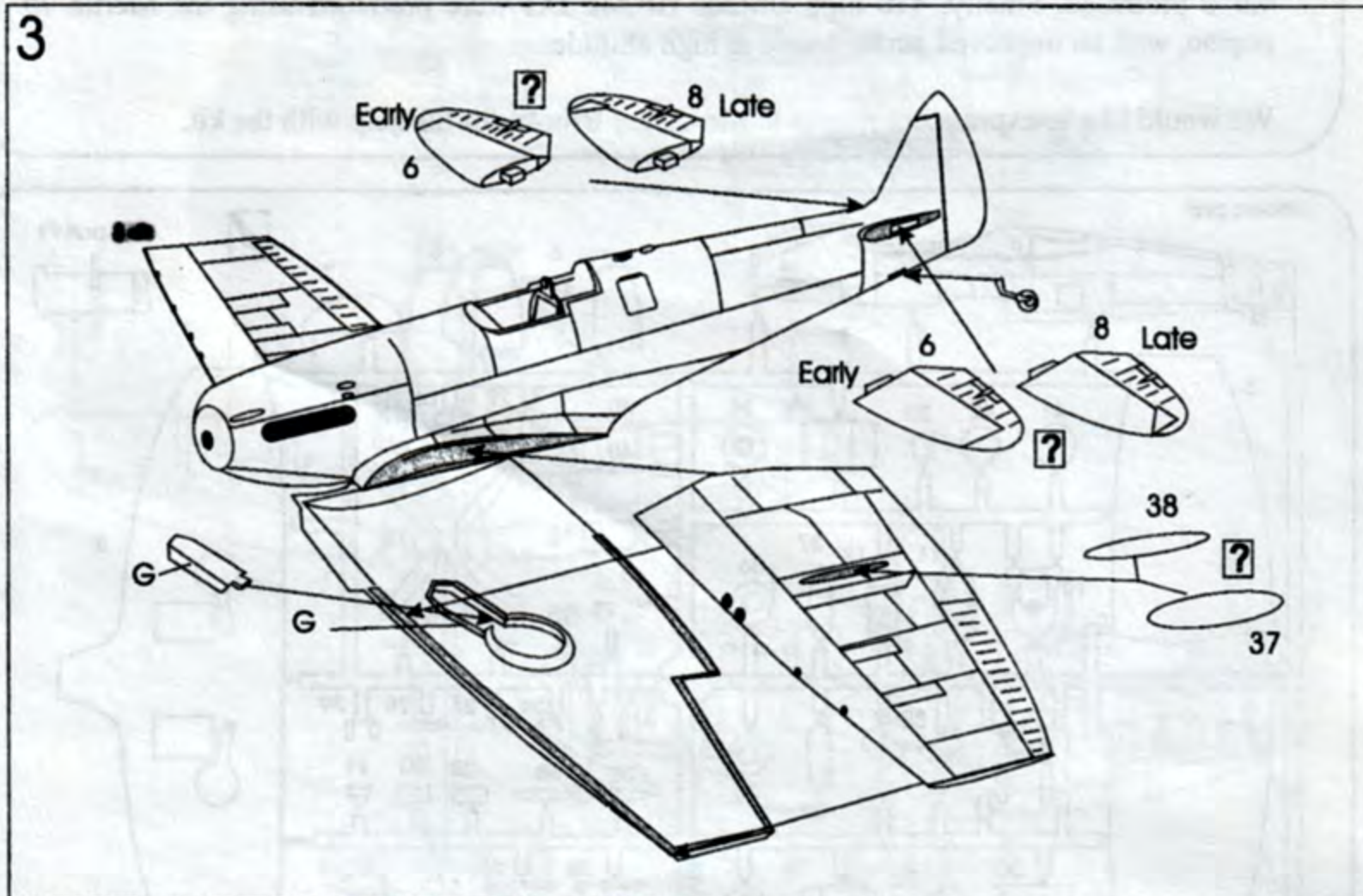
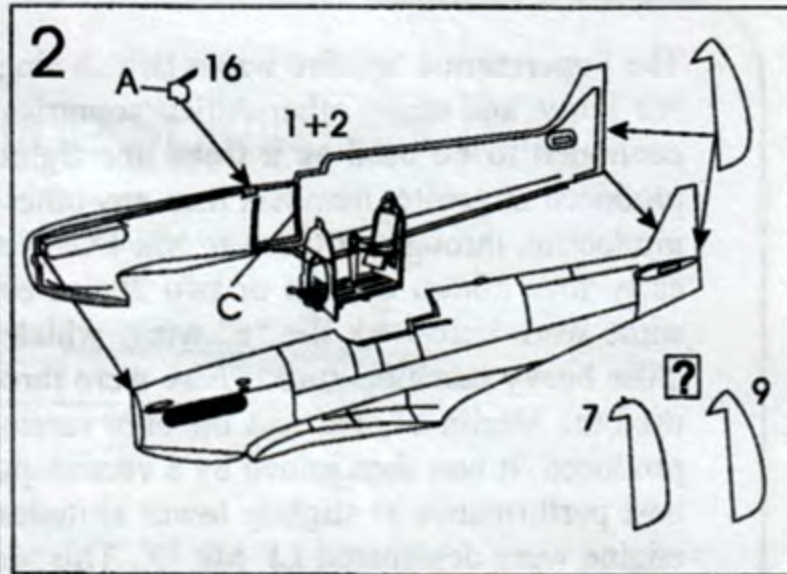
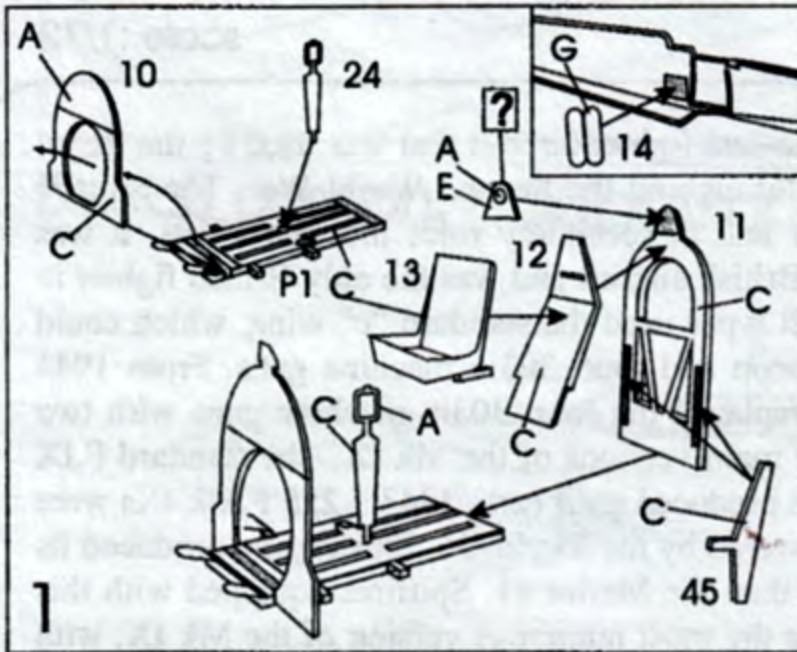
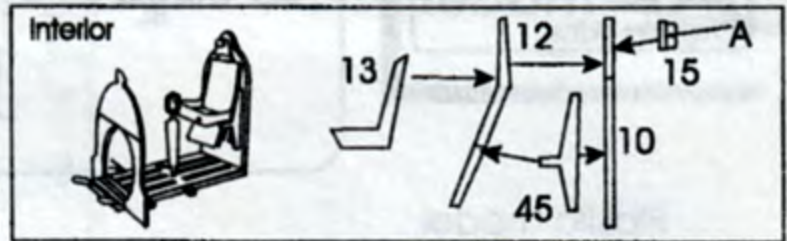

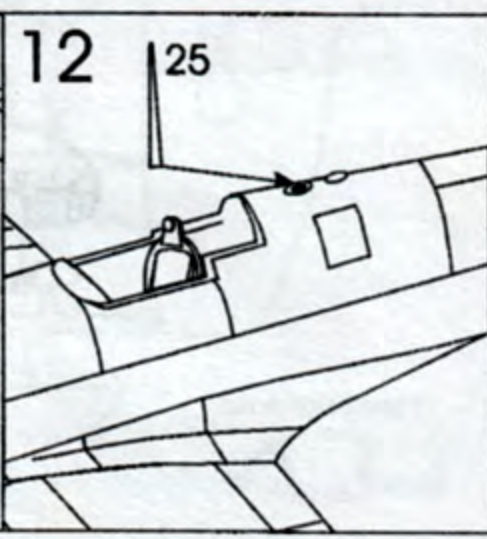
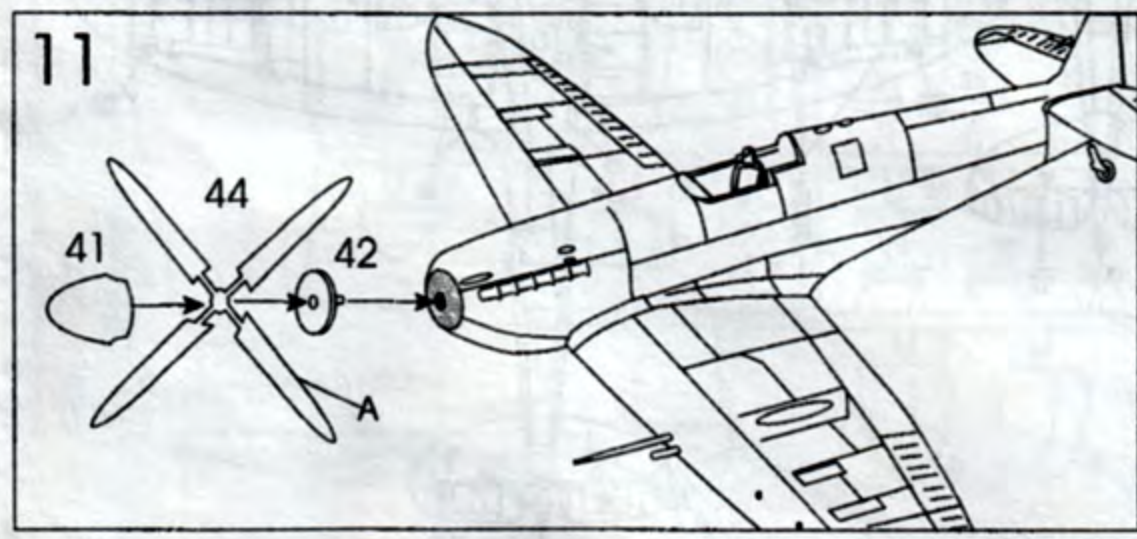
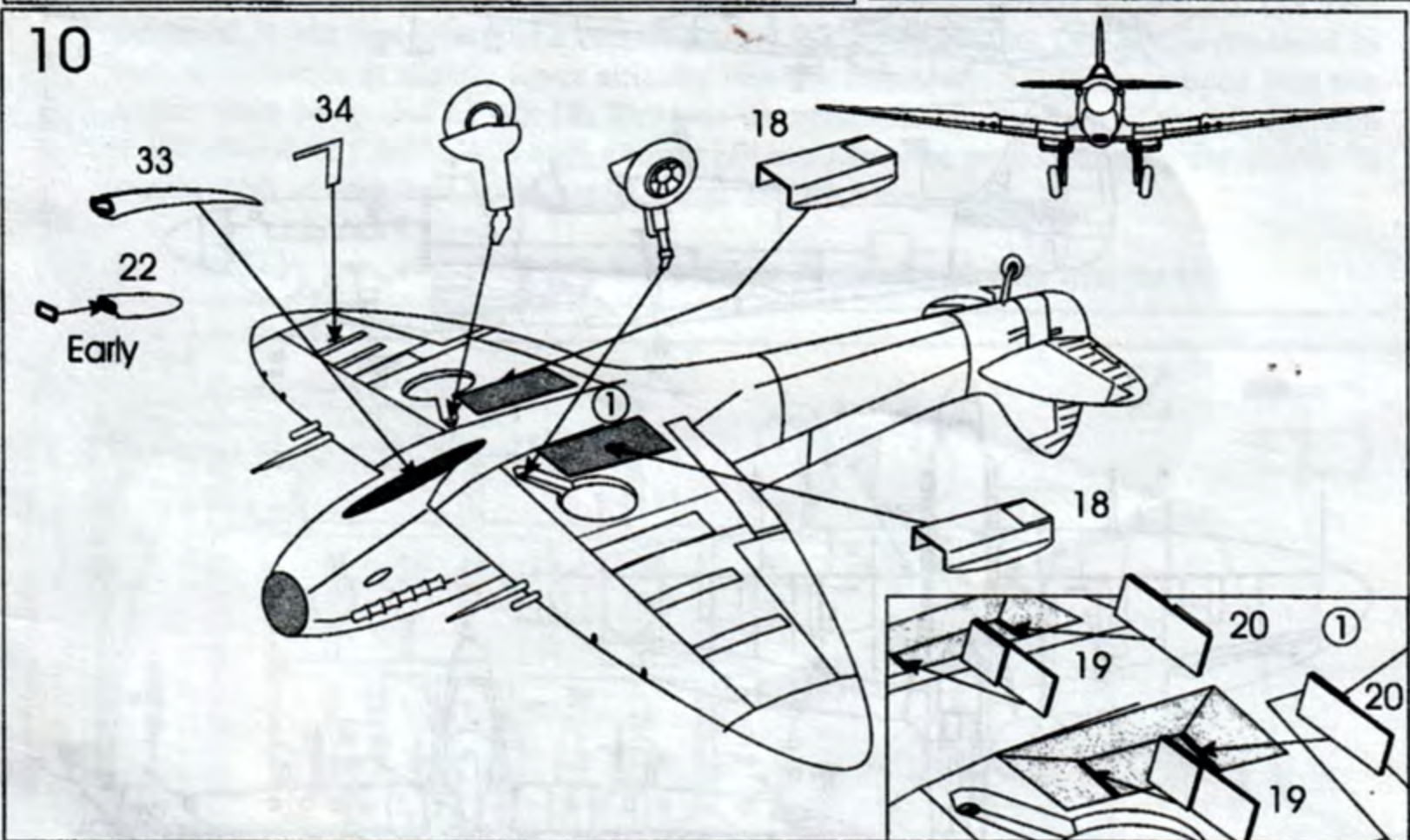
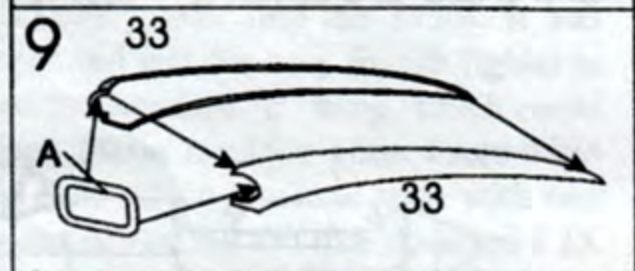
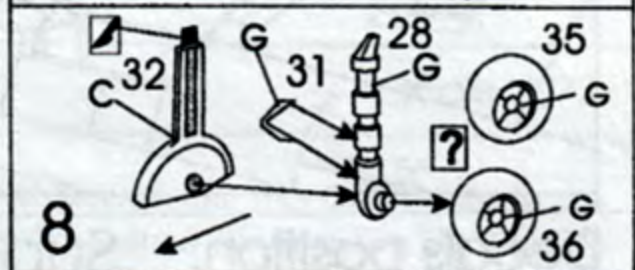
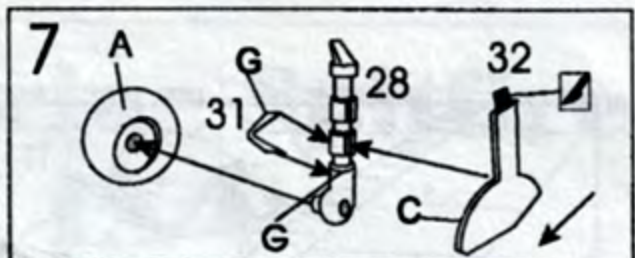
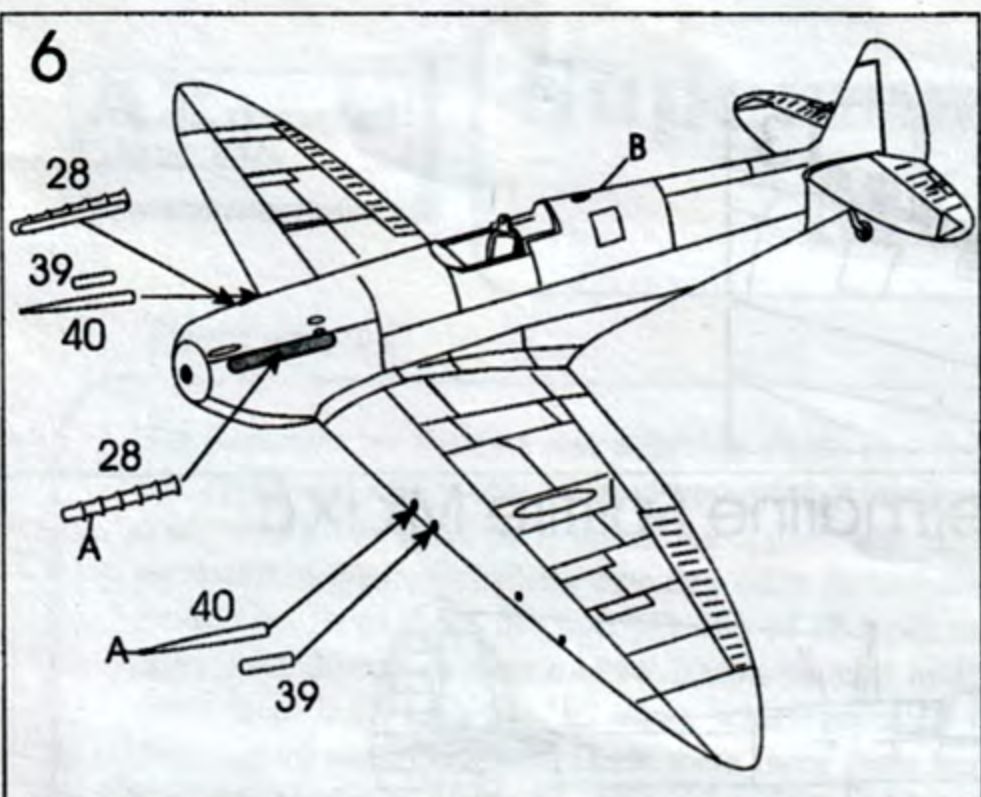

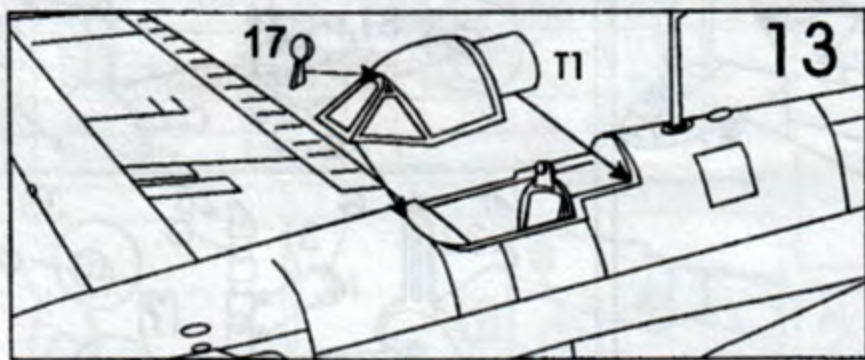

Decals position: Supermarine Spitfire Mk IXc

