

LOCKHEED P-2H(P2V-7) NEPTUNE

1/72 Scale Series

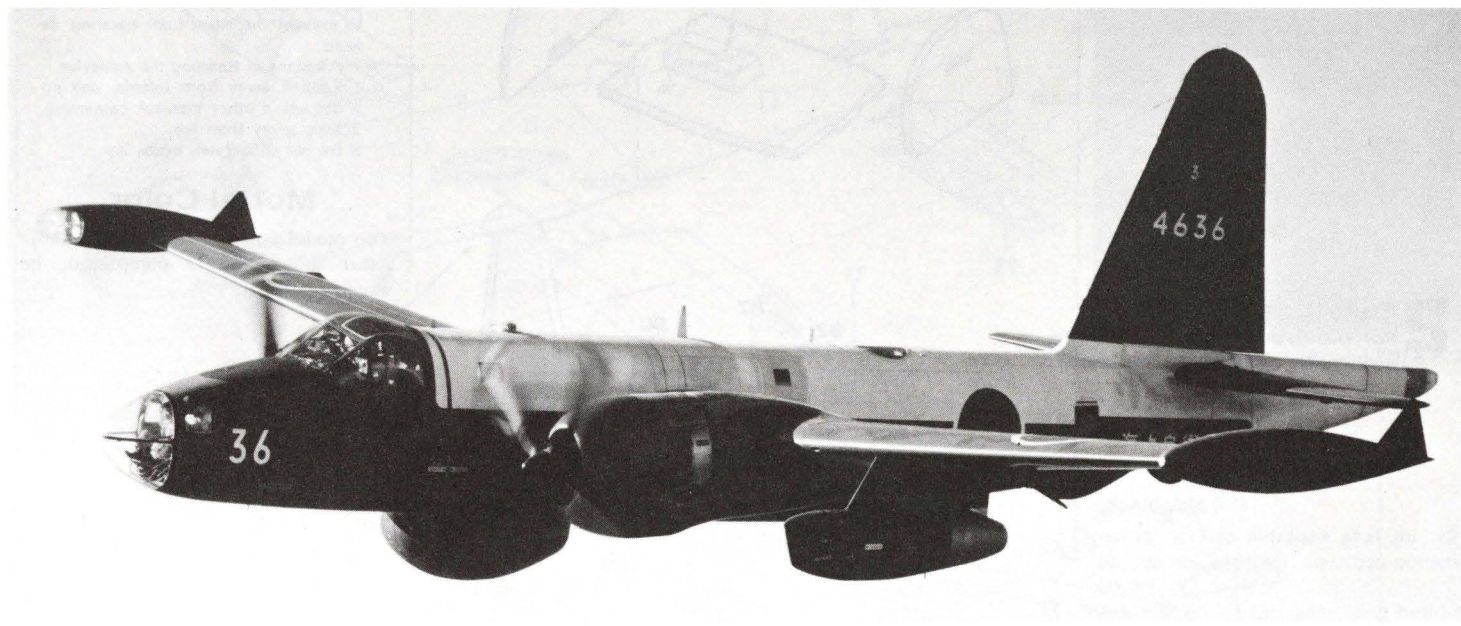

<P-2J>

History

The original model of this anti-submarine patrol plane for a long range was first designed in 1944, with its successful maiden flight on May 17, 1945. Until now it has been the front line patrol plane, and through the numerous and major improvements it was very active in many countries.

The P-2H (P2V-7) was the last model, appearing in 1954. In 1946, the original XP2V-1 patrol plane set a world record on long distance rectilinear flight and was considered as one of the masterpieces of that time. Because of the advancement on the submarines and anti-submarine warfare, this plane was mainly used for submarine patrol. The long magnetic detector (MAD) is extended to the back of the fuselage, mammoth radar dome below the fuselage, ECM, wing tip with 70 thousand candle power searchlight, sonar buoy, the bomb bay loaded with torpedo, bombs, rockets for submarine attack. This plane is able to patrol for many hours, from 12 to 18 hours, without refueling. The 20% wing thickness manifests satisfactory aerodynamical efficiency, and by the device on the horizontal stabilizer, the half of which is movable, it maintains proper maneuverability during the speed and gravity change of a wide range.

After the Model 5, two J34 jet engines (fuel identical to the main engine) were installed, to improve the take-off and landing perform-



<P-2J>

ance and to elevate the speed during the fight action and furthermore to increase its stability. Because of its special type of duty, the demand for greater cruising range and all weather performance, these equipments and crew facilities were well established. But on the other hand the high altitude performance was not up to expectation. This plane was the main force for the Japanese Maritime Self Defense Force for anti-submarine patrol. With the P2V-7 as the nuclear, it was remodeled to equip with the latest anti-submarine armaments. The remodeled plane became the domestic made Kawasaki P-2J. It is 1.3m longer than the P2V-7, the interior space



<P-2J>

enlarged and the engine replaced with the turbo-prop. The 4 blades propeller was changed to 3 blades one, and the auxiliary engine was changed to the domestic J3-8. In the landing gear the single wheel was changed to dual wheels (smaller size). The shape of the vertical tail and the space area on the rudder became larger. The radar dome became very compact.

However, rather than the outer appearance the more important point was the change on the anti-submarine armaments, the P-2J was equipped with the modern ones. The engine output became smaller than the P2V, but with its remodeling the entire weight became 4.5 tons lighter and performance increased considerably. Until the next jet anti-submarine plane PX-L is completed, this P2V-7 will still be the major force for the Japanese Maritime Self Defence Force.

Data

Engine: Right R-3350-32WA, 3,750Hp x 2 + Westinghouse J34WE, 1,542kg. x 2 / Overall Width: 30.89m / Overall Length: 27.94m / Overall Height: 8.94m / Wing Area: 92.9m² / Dead Weight: 30,618kg. / Rate of Climb from Sea Level: 770m/min. Maximum Speed: Mach 0.47 / Service Ceiling: 7,620m / Cruising Range: 7,400km / Armament: Torpedo x 4, or 150kg. Bomb x 16, 127mm Rocket x 8

Turbo-Prop Engine

10% of the effective power remains in the injected gas and by the remaining 90% the propeller is powered, which is the principle of the gas turbine engine. The 10% of the effective power, in the injected gas, is utilized in the form of driving force. This engine satisfactory for take-off, because of its great driving force at low speed, but because of the propeller drive it can not deliver the maximum flight speed. Recently this engine has made inroad upon the engine for light planes, because of its low price and economy that solves one of the various problems.

1 Cockpit Assembly

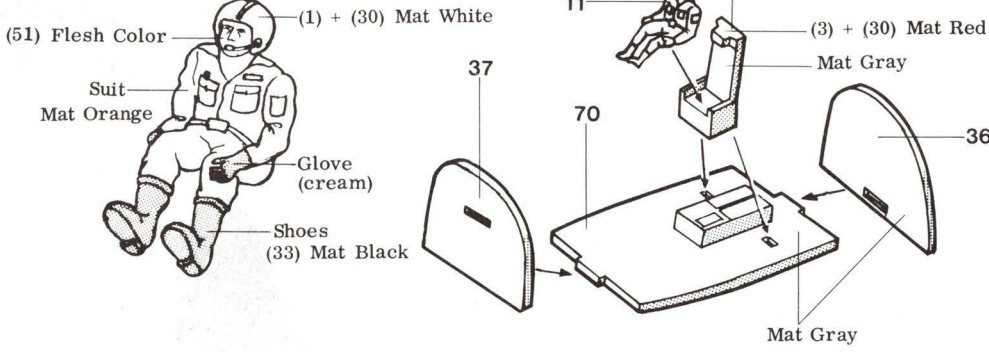

Read This Before Assembling

- * Carefully read the instructions before assembling your model and follow them.
- * Carefully cut off the parts from the stem with a knife or a clipper.
- After removing the parts from the bag, cut it in pieces and throw it away ... to prevent the infant from covering its head.
- Precautions in Handling the Adhesive
 1. Keep it away from infants, and do not use it other than for cementing.
 2. Keep away from fire.
 3. Do not deliberately inhale it.

Model Color

The model colors are from (1) - (60). After the model is completed, be sure to paint it.

2 Fuselage Assembly

For U.S. Navy Model, fit on the automatic cannon 72, 59 and 87.

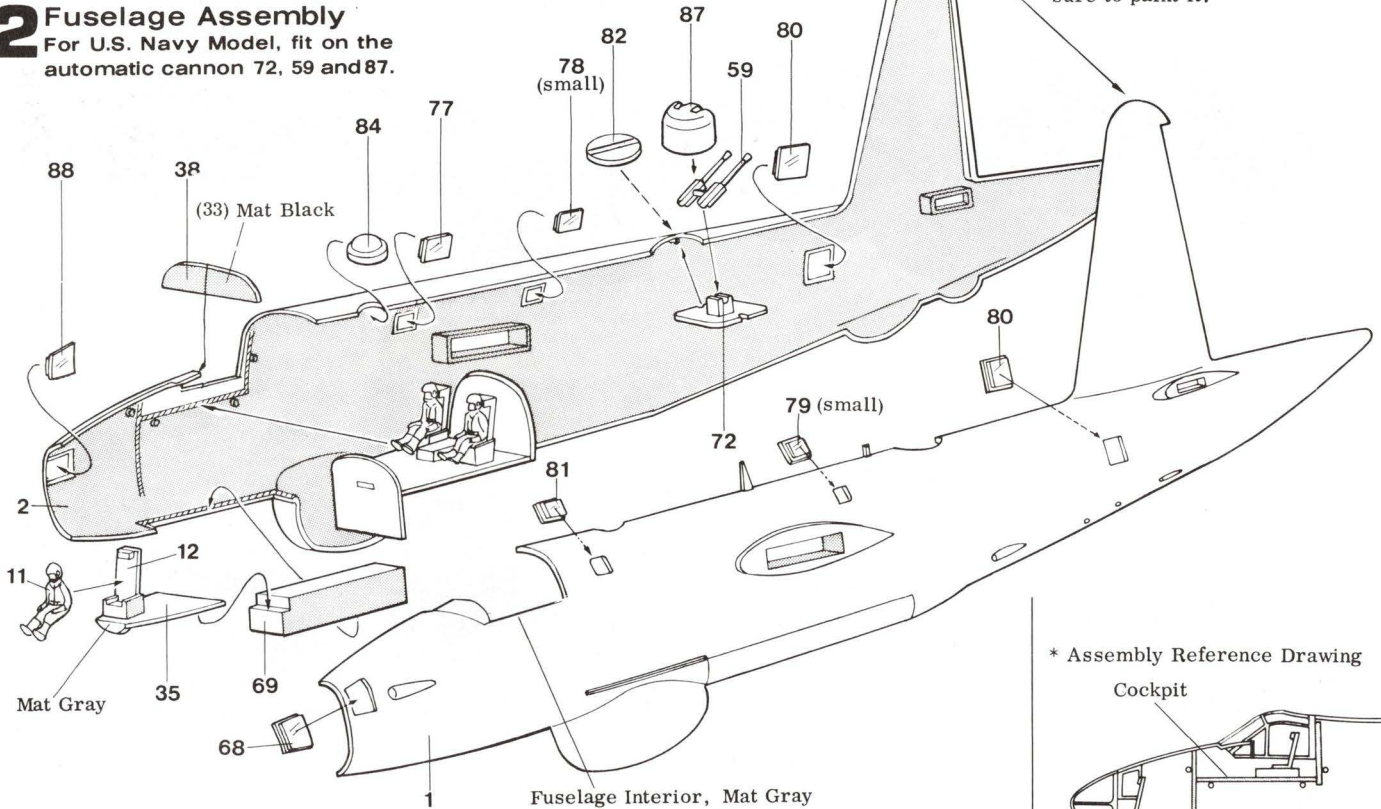

Place a weight, about 30 grams, in front of the fuselage.

* Assembly Reference Drawing

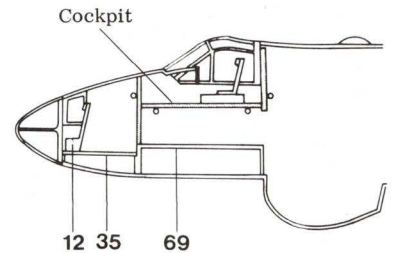

3 Engine Assembly

Make 2 sets.

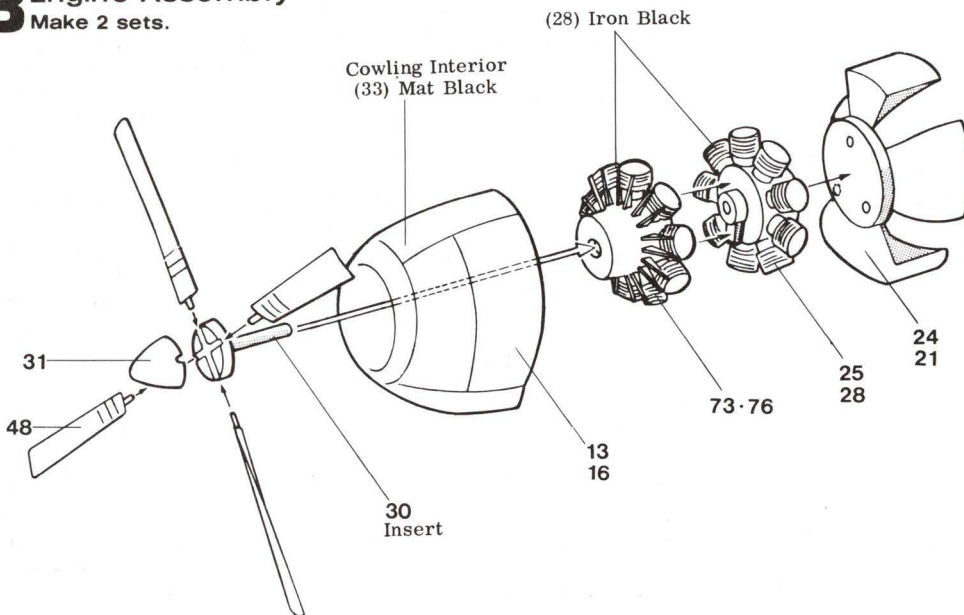

* Reference Drawing on Painting the Propeller

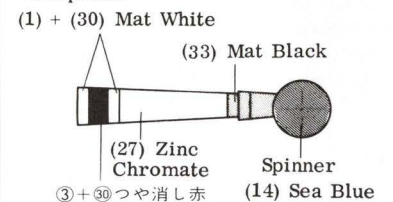

4 Main Wing, Tail Wing Assembly

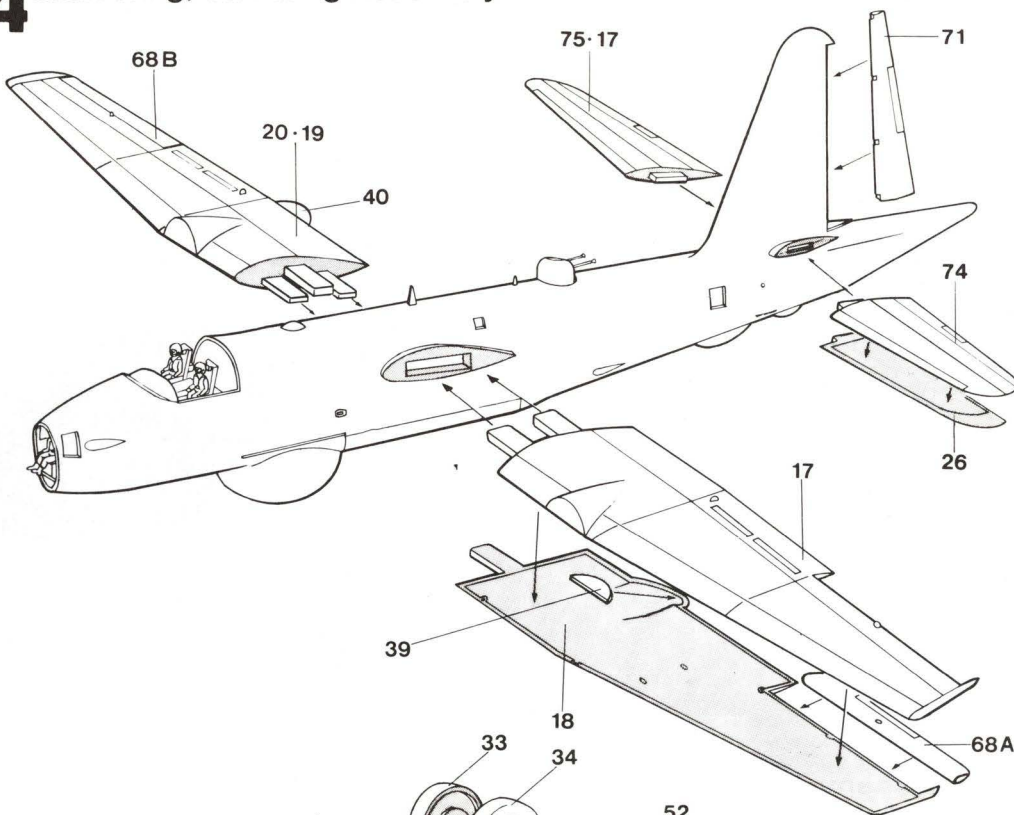

5 Main Landing Gear Assembly (left side)

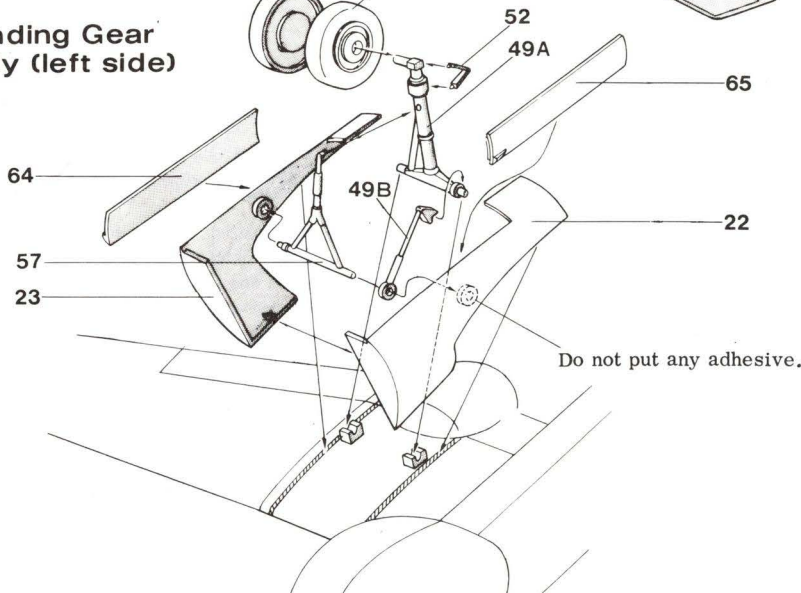

6 Main Landing Gear Assembly (right side)

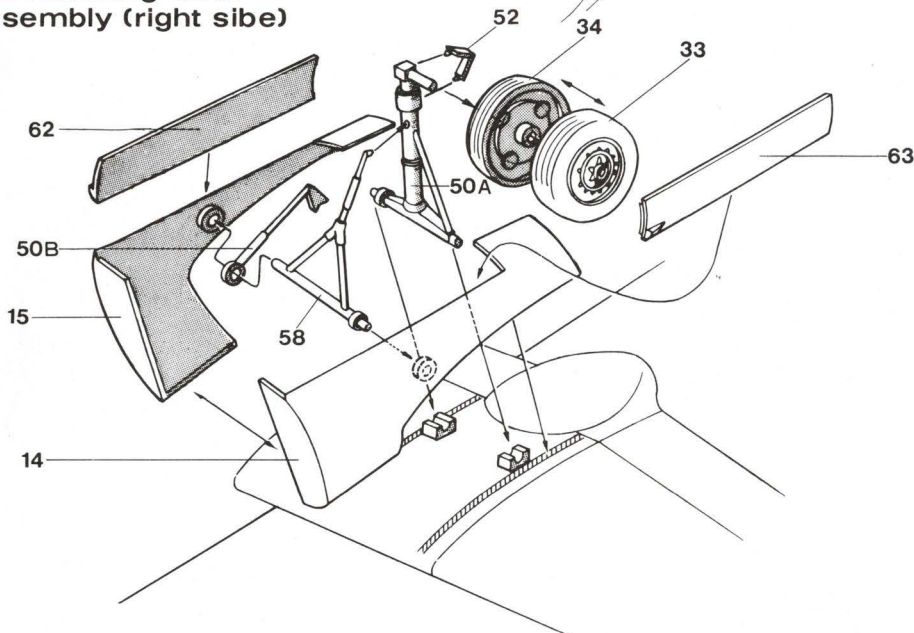

Actual Plane P-2V

Drawing-5

Insert 57 to retainer part on 22 23 (do not cement), and then cement 22, 23.

Cement 49 to the main wing bottom and at the same time cement the assembled engine nacelle 22, 23 to the main wing bottom.

Painting Reference

- Tire (33) Mat Black
- Wheel (8) Silver
- Landing Gear, Torque Link (8) Silver
- Landing Gear Cover, Interior (1) + (30) Mat White

Drawing-6

Insert 58 to retainer on 14, 15. (do not cement), and then cement 14, 15.

Cement 50 to the main wing bottom and at the same time cement the assembled engine nacelle 14, 15 to the main wing bottom.

Reference Picture of Propeller



7 Nose Wheel Assembly

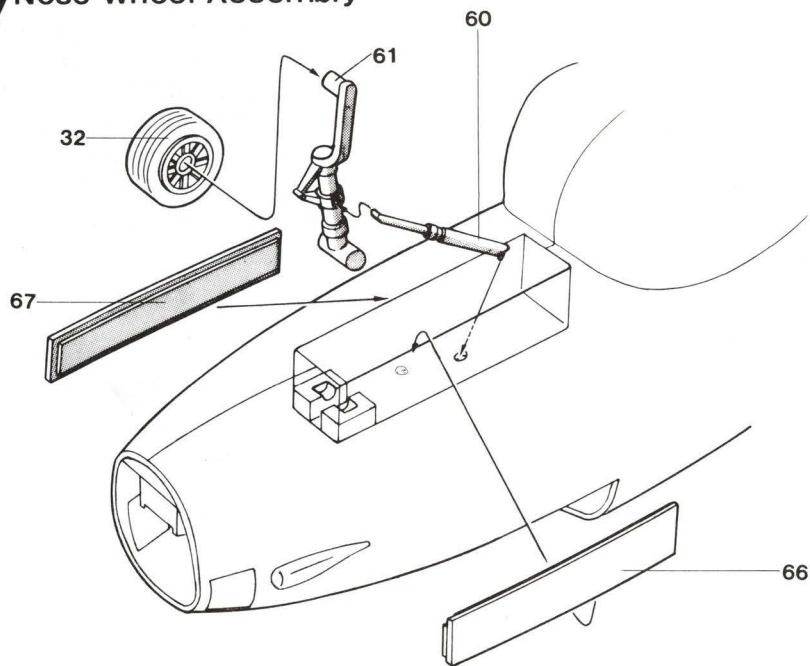

* Reference on Painting
 Tire (33) Mat Black
 Landing Gear (8) Silver

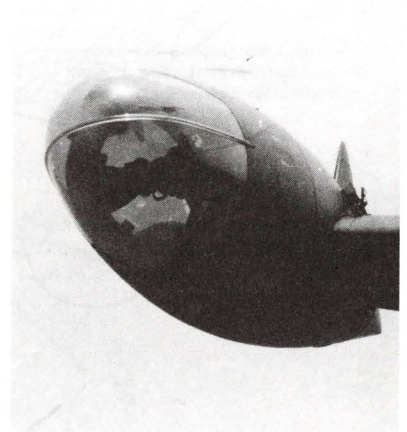

Reference Picture of Searchlight

8 Exhaust Pipe, Cowling Flap Assembly

(right side, the same)

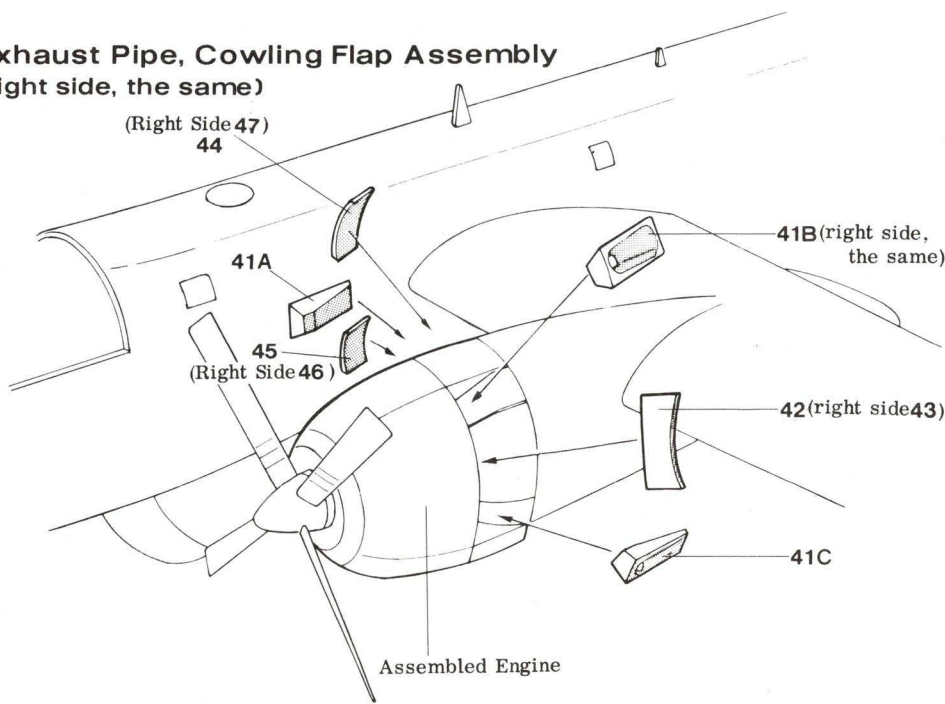

* Reference Drawing on Exhaust Pipe Fitting

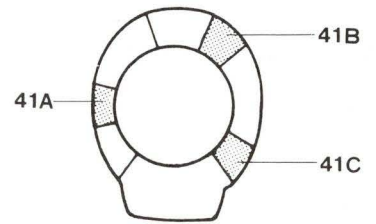

* Reference Drawing on Cowling Flap Fitting

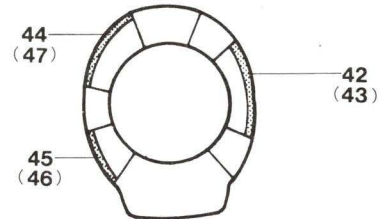

Reference Picture

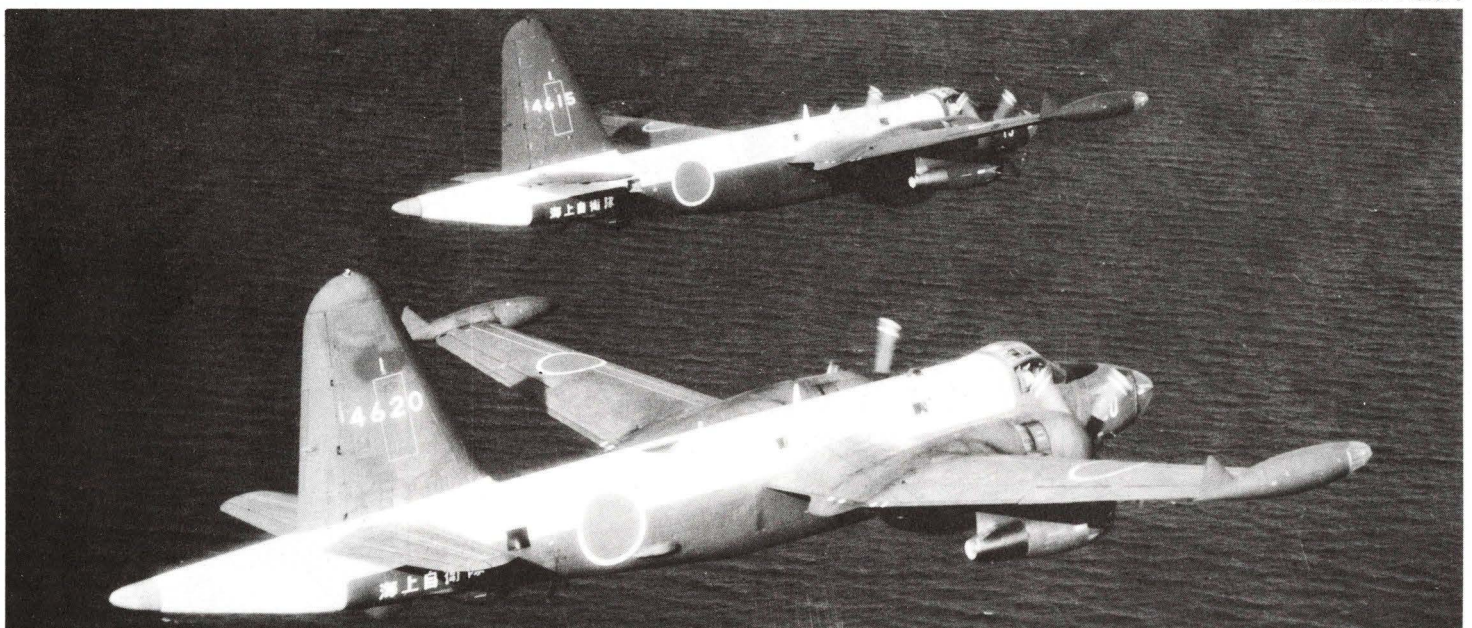

9 Engine, Auxiliary Fuel Tank Assembly

Assemble 2 sets.

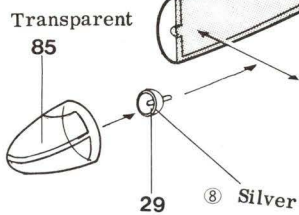
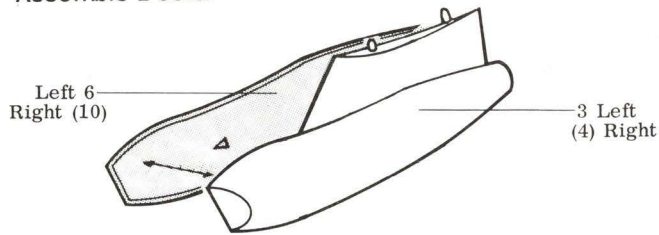

Engine (P-2J) Reference Picture



Radar Dome (P-2J) Reference Picture



Nose (P-2J) Reference Picture

10 Parts Fitting

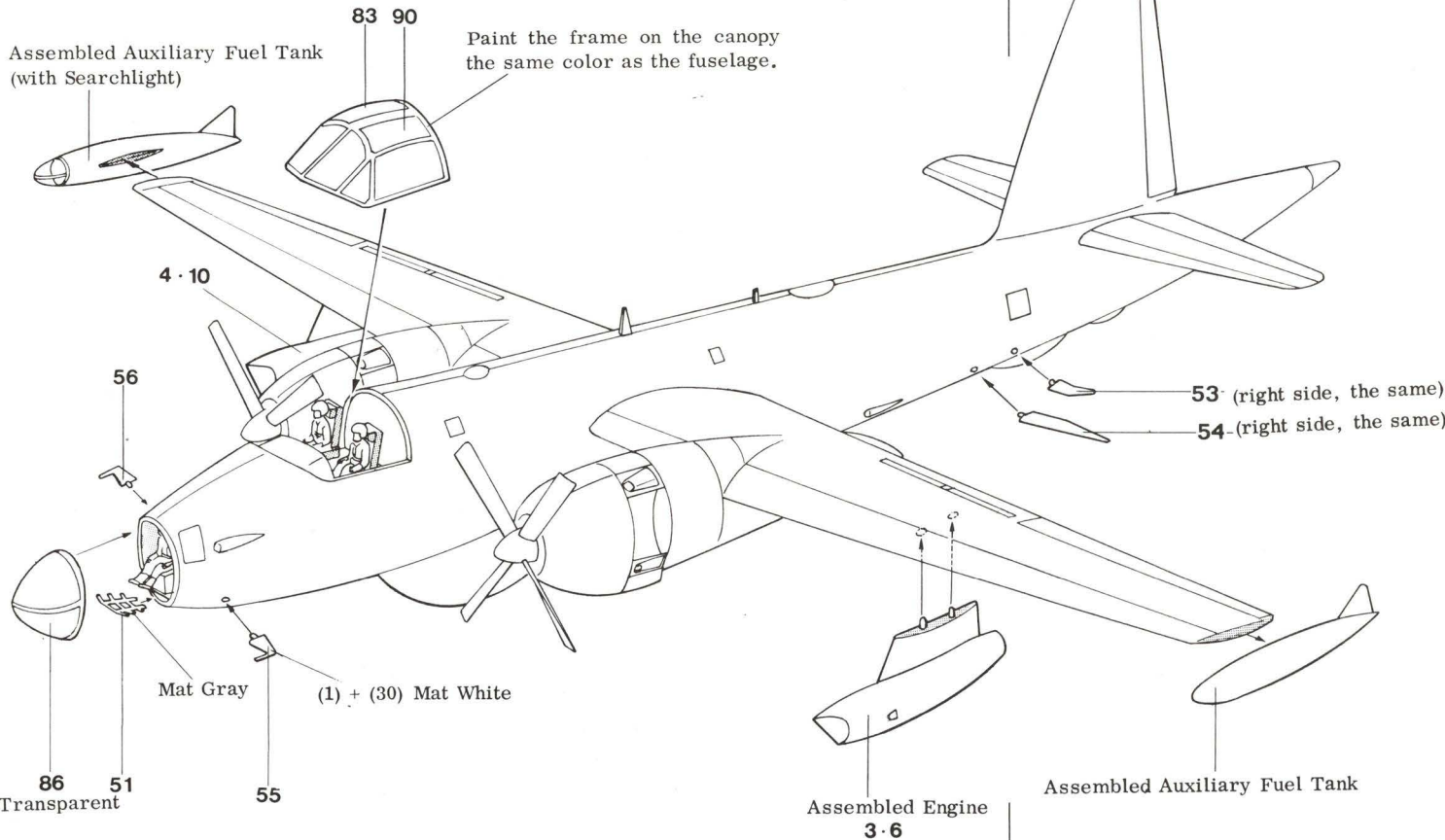

Marking & Color Painting Guide

Applying Decals

1. Wipe and clean the area, where the decal is to be positioned, from dust or oiliness with a wet rag.
2. Cut out the decal and remove the film covering.
3. Place in lukewarm water, transfer the decal when the paper becomes flat.
4. Slide off the decal from the paper and position it at the proper place.
5. Press the transferred decal with a soft cloth, to adhere to the model and to remove the excess moisture.
6. Do not touch the decal until it is well dried.

Model Color

The number for the model colors is from (1) - (60). After the kit is assembled, paint the necessary colors.

Main Colors to be used

- (14) Sea Blue (Navy Blue) Entire Fuselage
- (1) White Mat white for fuselage top, interior of landing gear cover.
- (33) Mat Black Tire, Engine
- (30) Flat Base Adaptive for mat color, use for mat finish on original color.
- (8) Silver Landing Gear, Wheel, etc.

Other Colors for Accentuation

- (3) Red Mat finish for headrest, propeller, etc.
- (27) Zinc Chromate Propeller
- (28) Iron Black Engine, Automatic Cannon, etc.
- (51) Flesh Color Pilot

To paint a wide area, use a flat brush; for pilots and other small parts use a thin brush. After the painting, be sure to wash the paint brush in paint thinner.

U.S. Navy 1st Patrol Squadron

-  ① White (FS No. 17875)
-  ② Gull gray (FS No. 36440)

CANOPY FRAME

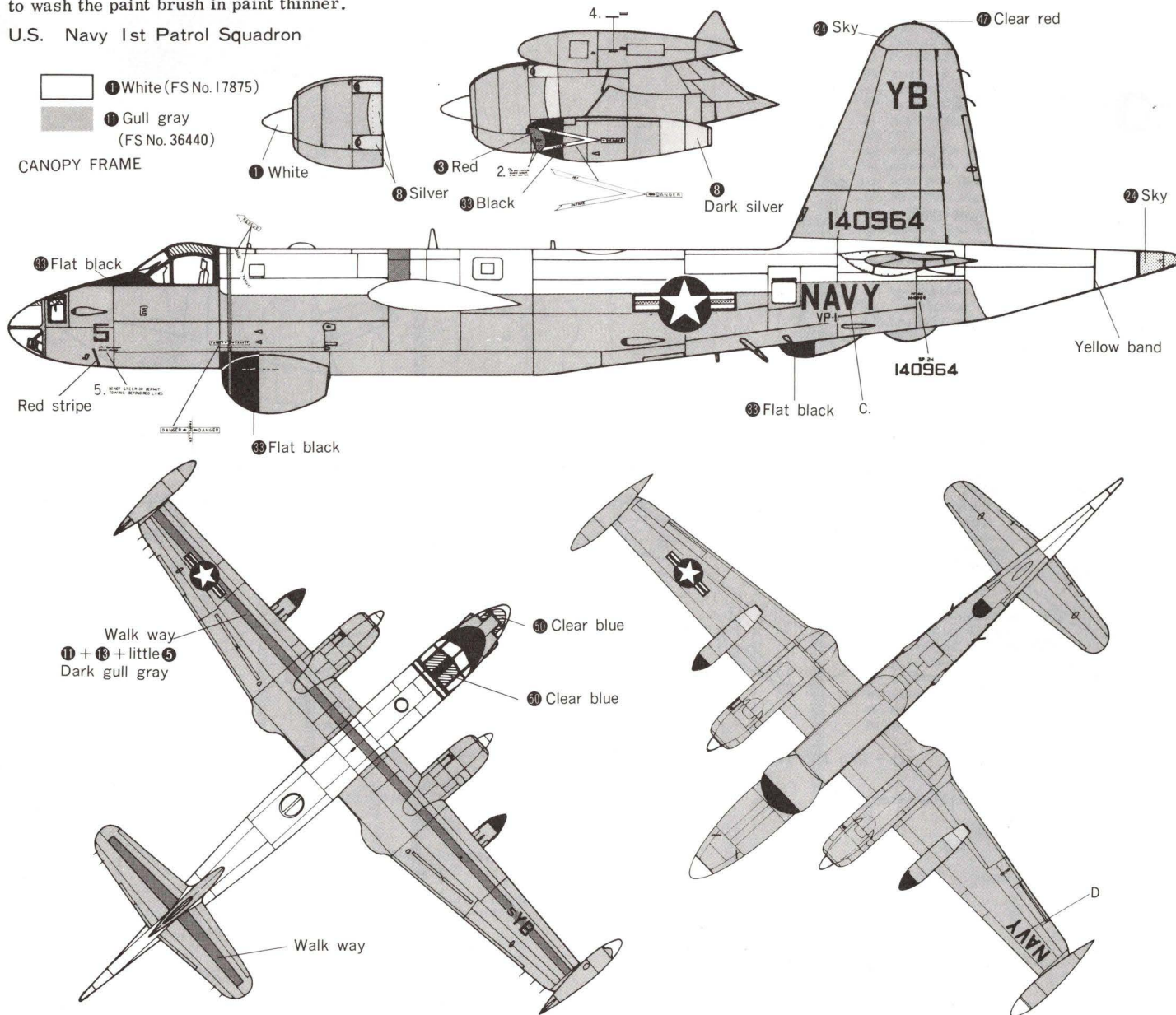

Wheel Painting

After the left and right wheel are cemented, and the burrs and rough adhesive are corrected, paint it. Insert a toothpick into the shaft hole, rotate it and paint.

Stick the toothpick into a lump of putty for drying.

Engine Painting

Since it is difficult to paint the engine correctly while it is still on the stem, remove it from the stem and insert a toothpick and paint.

Paint it completely with black; then slightly splash a silver tint.

Landing Gear Chassis Painting

On small parts without a hole, grip the piece with a clip or a laundry clip and paint. Paint the parts lightly and go over it about 2 times.

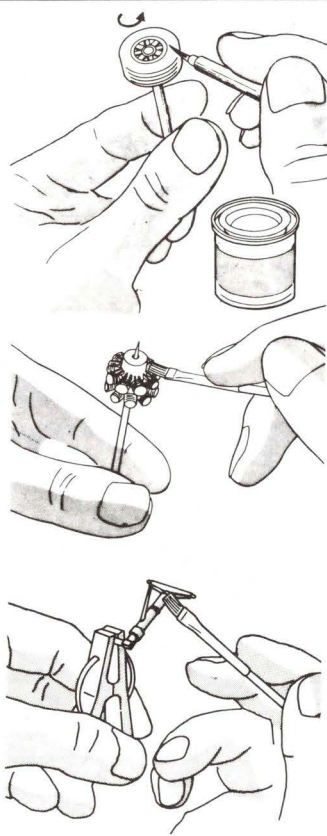

JMSDF 4th Wing 3rd Squadron

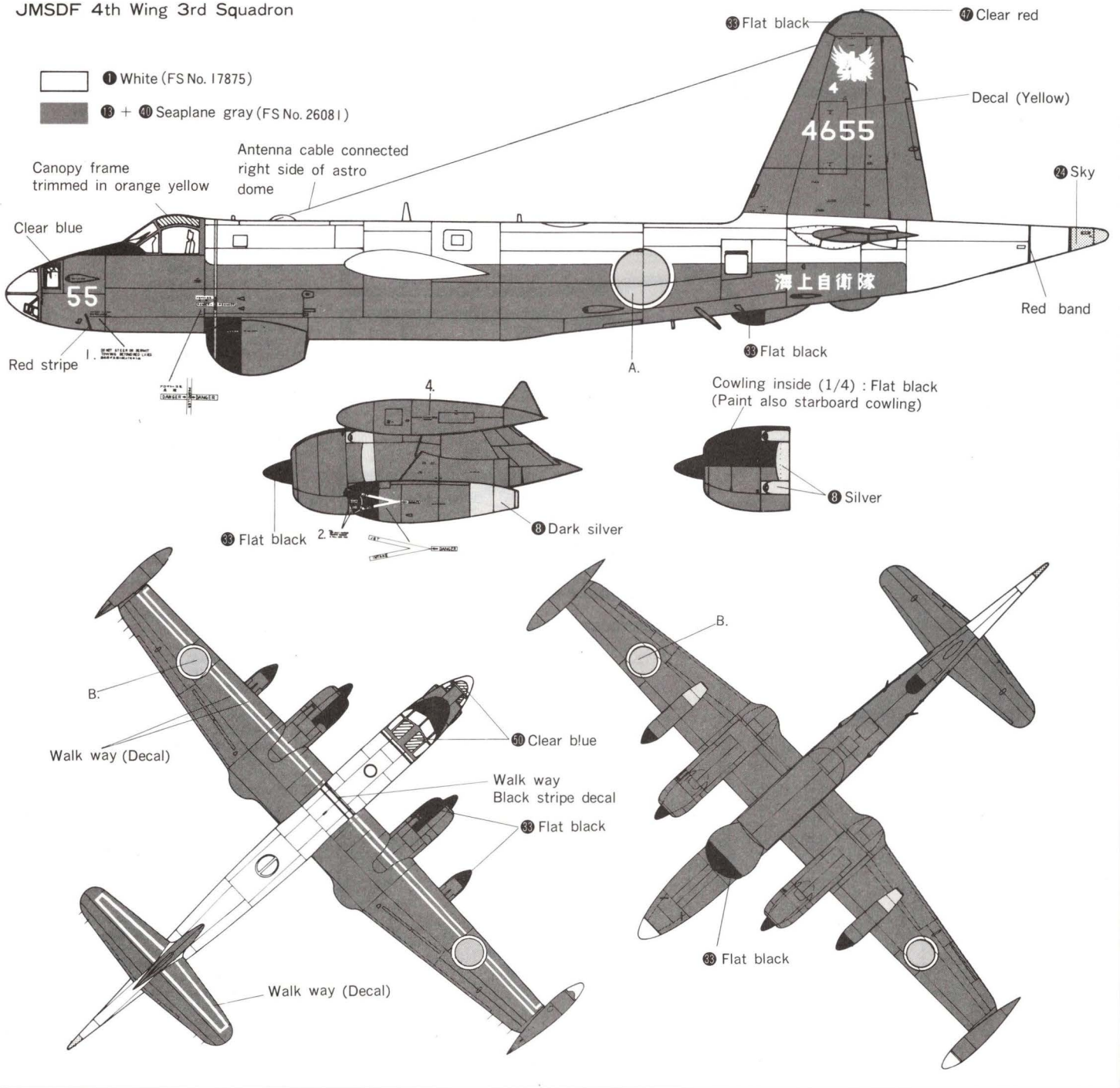

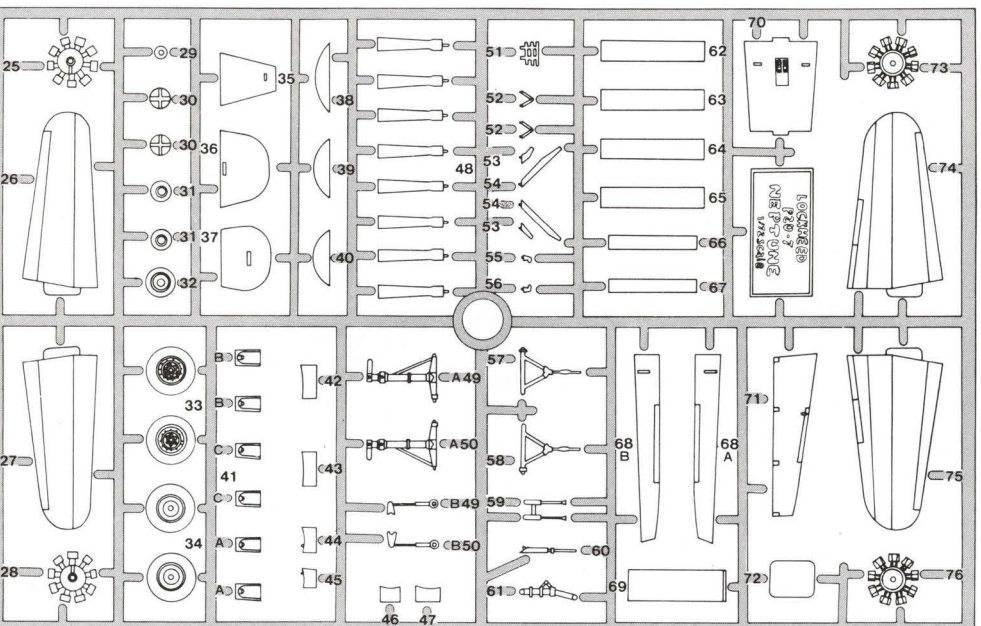
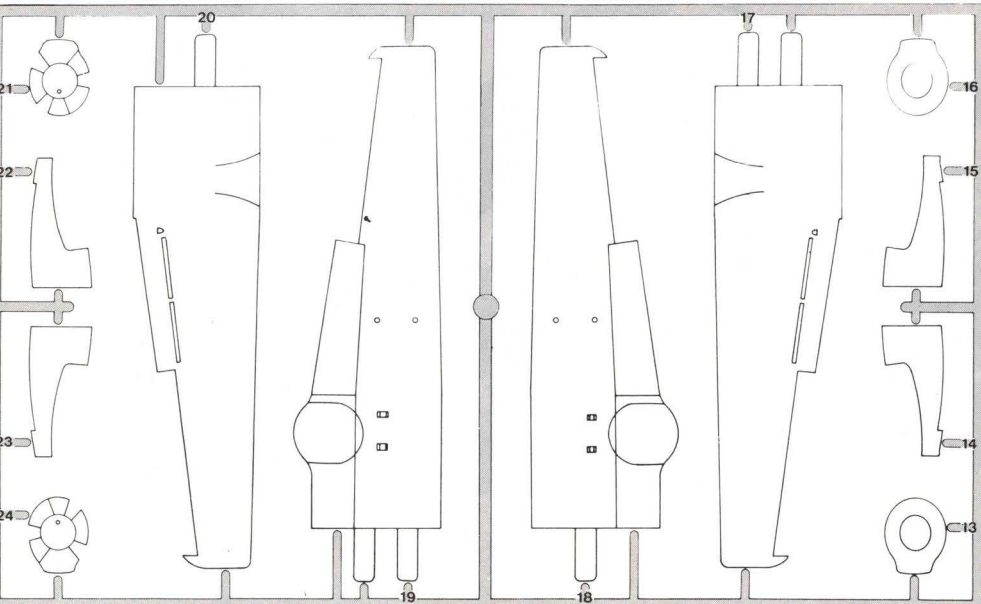
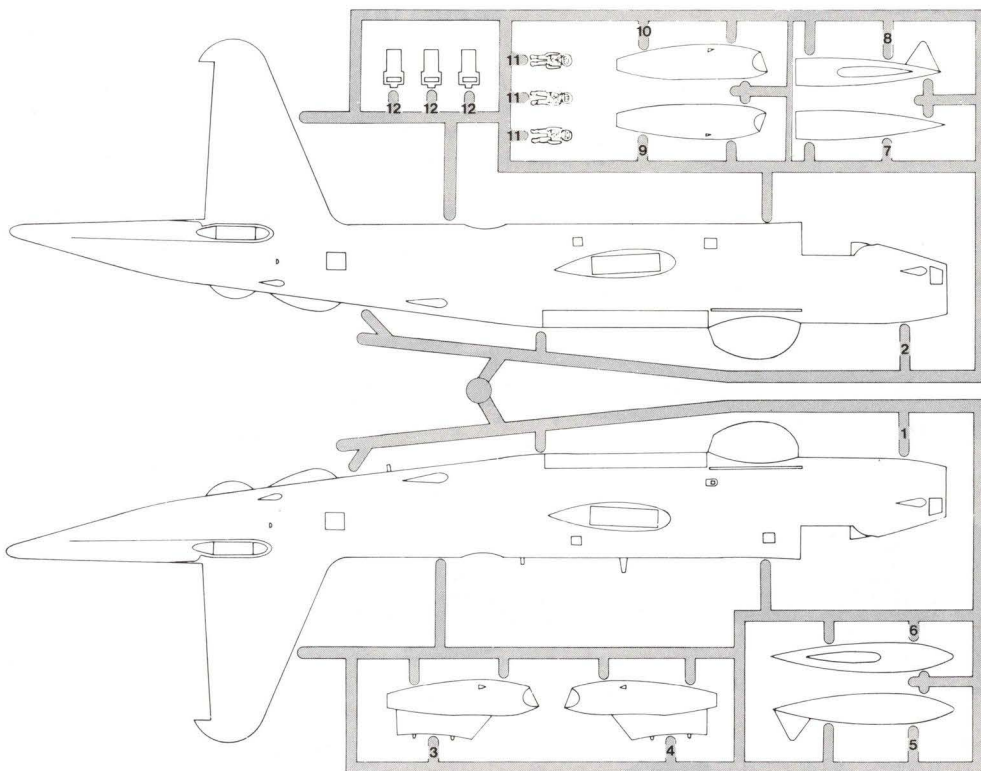

Parts

1. Fuselage (left)
2. Fuselage (right)
3. Jet Engine (left) (outer side)
4. Jet Engine (right) (outer side)
5. Wing Tip Auxiliary Fuel Tank (left)
6. Wing Tip Auxiliary Fuel Tank (right)
7. Searchlight (right)
8. Searchlight (left)
9. Jet Engine (left) (inner side)
10. Jet Engine (right) (inner side)
11. Pilot
12. Seat
13. Cowling
14. Engine Nacelle (right)
15. Engine Nacelle (left)
16. Cowling
17. Main Wing Top (left)
18. Main Wing Bottom (left)
19. Main Wing Bottom (right)
20. Main Wing Top (right)
21. Engine Bracket
22. Engine Nacelle (right)
23. Engine Nacelle (left)
24. Engine Bracket
25. Engine (back)
26. Horizontal Tail Wing Bottom (left)
27. Horizontal Tail Wing Bottom (right)
28. Engine (back)
29. Searchlight Reflector
30. Spinner (back)
31. Spinner (front)
32. Nose Wheel
33. Landing Wheel (outer side)
34. Landing Wheel (inner side)
35. Nose Floor
36. Bulkhead (back)
37. Bulkhead (front)
38. Instrument Panel
39. Main Wing Top Parts
40. Main Wing Top Parts
41. Exhaust Pipe (A) (B) (C)
42. Cowling Flap (C)
43. Cowling Flap (C)
44. Cowling Flap (A)
45. Cowling Flap (B)
46. Cowling Flap (B)
47. Cowling Flap (A)
48. Propeller
49. Landing Gear Parts (A) (B)
50. Landing Gear Parts (A) (B)
51. Nose Parts
52. Oleo
53. Antenna (B) (left, right)
54. Antenna (A) (left, right)
55. Pitot Tube (left)
56. Pitot Tube (right)
57. Landing Gear Parts (A) (left)
58. Landing Gear Parts (A) (right)
59. Automatic Cannon
60. Nose Wheel Strut
61. Nose Wheel Chassis
62. Landing Gear Hatch Door (right, inner side)
63. Landing Gear Hatch Door (right, outer side)
64. Landing Gear Hatch Door (left, outer side)
65. Landing Gear Hatch Door (left, inner side)
66. Nose Wheel Hatch Door (left)
67. Nose Wheel Hatch Door (right)
68. Aileron (A) (left), (B) (right)
69. Front Wheel Case
70. Cockpit Floor
71. Rudder
72. Cannon Mount
73. Engine (front)
74. Horizontal Tail Wing Top (left)
75. Horizontal Tail Wing Top (right)
76. Engine (front)
77. Canopy (B) (left)
78. Canopy (C) (left)
79. Canopy (C) (right)
80. Canopy (D) (right) (left)
81. Canopy (B) (right)
82. Canopy (E)
83. Cockpit Canopy (right)
84. Observation Window
85. Searchlight Front Parts
86. Nose Canopy
87. Automatic Cannon Cover
88. Canopy (A) (right)
89. Canopy (A) (left)
90. Cockpit Canopy (left)

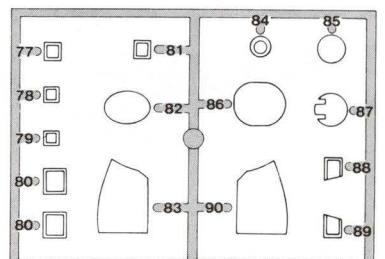

P2V-7 NEPTUNE `U.S.NAVY`

008971:72 P2V-7 ネプチューン “U.S.ネイビー”

LOCKHEED MARTIN, P-2 Neptune, [associated emblems and logos, and body designs of vehicles] are either registered trademarks or trademarks of Lockheed Martin Corporation in the USA and/ or other countries, used under license by Hasegawa Corporation.

Marking & Painting

マーキング及び塗装図
Markierungen und Bemalung
Décoration et Peinture
Marchio & Pittura
Decoración y Pintura
標貼及着色指示

1 アメリカ海軍 第19哨戒飛行隊
VP-19 U.S.NAVY
P2V-7S

2 アメリカ海軍 第21哨戒飛行隊
VP-21 U.S.NAVY
SP-2H

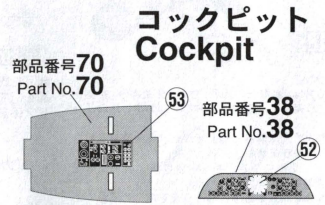
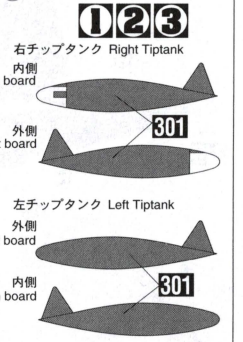
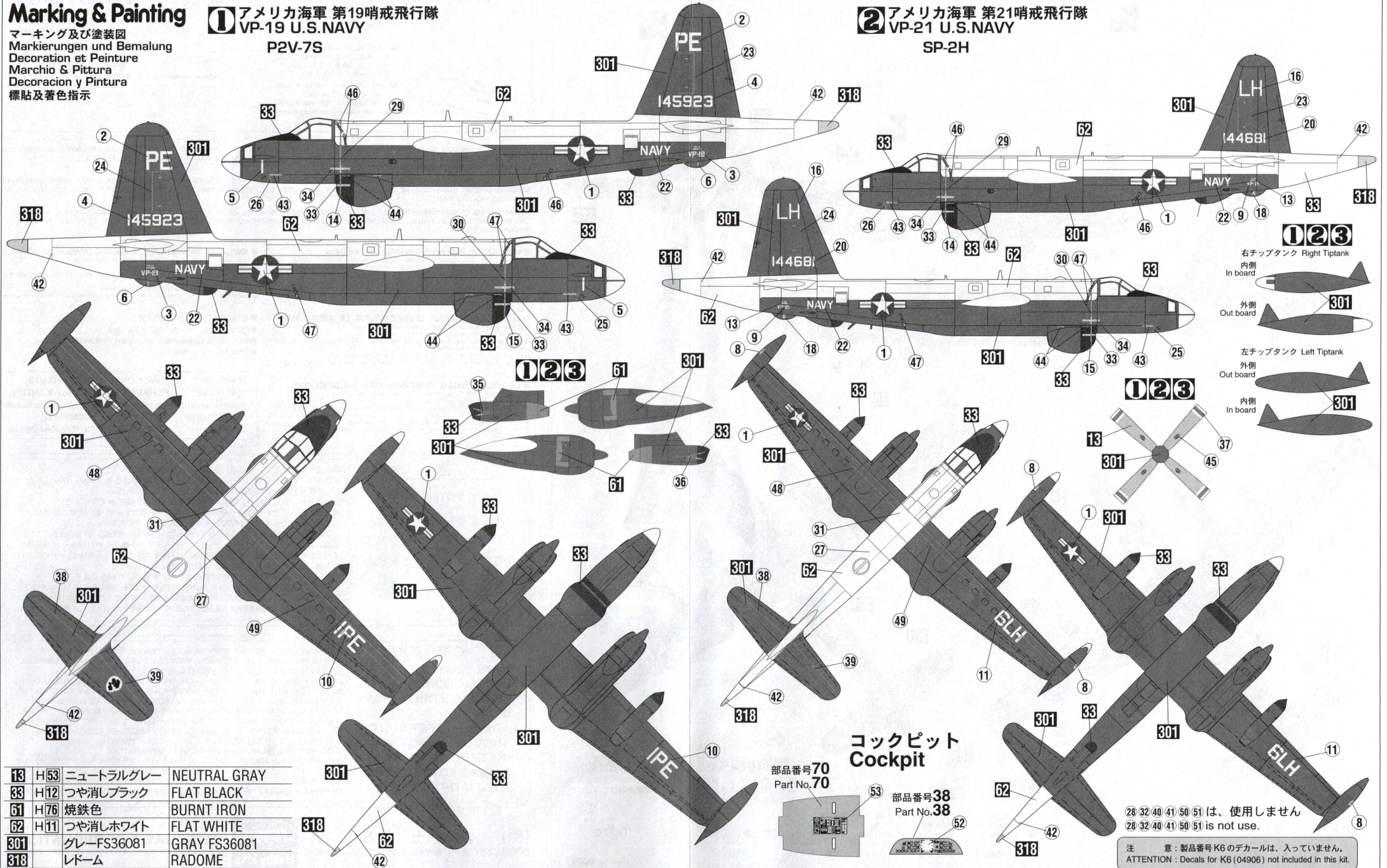

13	H53	ニュートラルグレー	NEUTRAL GRAY
33	H12	つや消しブラック	FLAT BLACK
61	H76	焼鉄色	BURNT IRON
62	H11	つや消しホワイト	FLAT WHITE
301		グレー-FS36081	GRAY FS36081
318		レドーム	RADOME

28 32 40 41 50 51 は、使用しません
28 32 40 41 50 51 is not use.
注 意：製品番号 K6 のデカールは、入っていません。
ATTENTION: Decals for K6 (04906) not included in this kit.



切り取ってください。
REMOVE
ENTFERNEN
RETIRER
SEPARARE
CORTAR
切去

3 アメリカ海軍 第21哨戒飛行隊 VP-21 U.S.NAVY

SP-2H

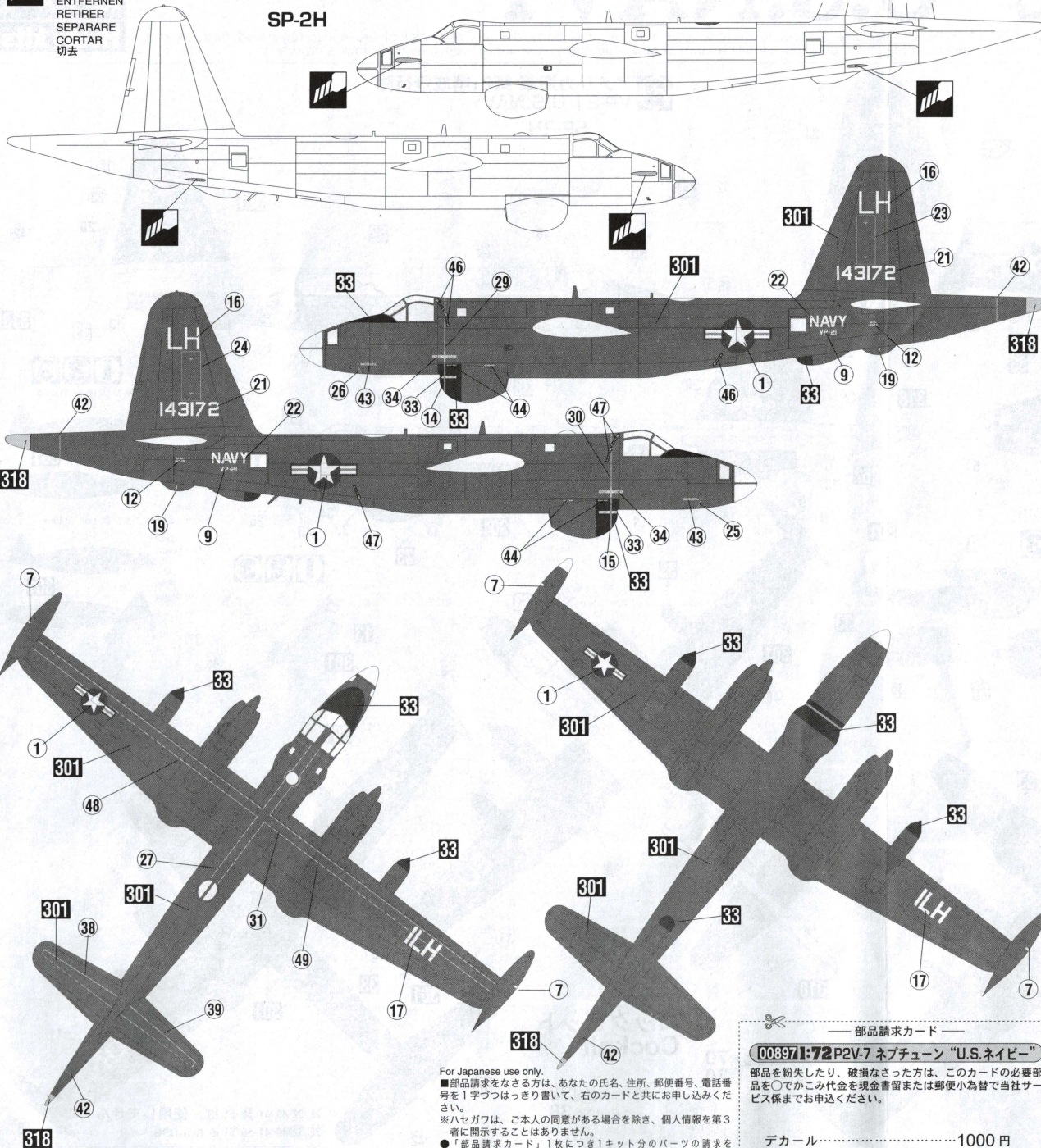

For Japanese use only.
■部品請求をなさる方は、あなたの氏名、住所、郵便番号、電話番号を1字づつはっきり書いて、右のカードと共に申し込みください。
※ハセガワは、ご本人の同意がある場合を除き、個人情報をご第三者に開示することはありません。
●「部品請求カード」1枚につき1キット分のパーツの請求を受けることができます。
●右記の価格は予告なく変更する場合がありますのでご了承ください。

部品請求カード

008971:72 P2V-7 ネブチューン "U.S.ネイビー"

部品を紛失したり、破損なされた方は、このカードの必要部品を○でかこみ代金を現金書留または郵便小為替で当社サービス係までお申してください。

デカール.....1000円

0805

ART No. 00897

■デカールのじょうずな貼り方 Correct Method for Applying Decals

- デカールを貼るころのほりや汚れを、ぬらした布できれいにふきとってください。
- Clean model surface with wet cloth.
- 貼りたいデカールを台紙ごとハサミで切りとり、1枚づつ水またはぬるま湯に台紙を下にして20秒くらい浮かべます。
- Cut each design out of decal sheet and dip them in warm water for 20 seconds.
- 水から出したらタオルの上の指先でデカールが動かかぬかめた後、貼るところにおいて静かに台紙をずらします。
- Check with finger tip if design is loose on base paper. If so, place it on proper position on model and slide off base paper leaving design on model.

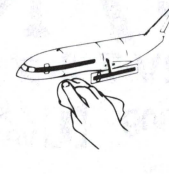
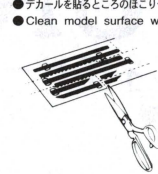

- 指先に少し水をつけて正確な位置にデカールを動かした後に、やわらかく、よく水を吸う布でデカールを押さえて内側の水分や気泡を押し出します。
- Move design to exact position with wet finger tip, and push out excess water and air bubbles under decal with soft cotton cloth.
- デカールが完全に乾いたら少し水をつけて布で、デカールのまわりのノリをふきとります。
- When decals get dry, wipe off with wet cloth excess glue left around decals.

ATTENTION: CE PRODUIT NE CONVIENT PAS A UN ENFANT DE MOINS DE 36 MOIS, EN RAISON DES PIECES DE PETITE DIMENSION. CONTIENE.

CAUTION: NOT SUITABLE FOR CHILDREN UNDER 3 YEARS. CONTAINS SMALL PARTS.

NICHT FÜR KINDER UNTER 36 MONATEN ENTHÄLT KLEINE TEILE.

ATTENZIONE: PRODOTTO NON ADATTO AI BAMBINI DI ETÀ INFERIORE AI 36 MESI. CONTIENE PICCOLE PARTI.

ATTENTIE: NIET GESCHIKT VOOR KINDEREN TOT 4 JAAR. BEBAT KLEINE ONDERDELEN.

ATENÇÃO: IMPRÓPRIO PARA CRIANÇAS COM MENOS DE 3 ANOS. CONTÉM PEÇAS PEQUENAS.

ATENCIÓN: NO ES CONVENIENTE PARA NIÑOS MENORES DE 3 AÑOS. CONTIENE PIEZAS PEQUEÑAS.

FORSIGTIG! IKKE EGNET TIL BØRN SOM ER MINDRE END 3 ÅR. INDEHOLDER SMÅ DELE.

ΠΡΟΣΧΗ : ΚΑΤΑΛΗΛΟ ΓΙΑ ΠΑΙΔΙΑ ΑΝΩ ΤΩΝ ΤΡΙΩΝ ΕΤΩΝ ΠΕΡΙΕΧΕΙ ΜΙΚΡΑ ΤΕΜΑΧΙΑ

■VOR DEM ZUSAMMENBAU ZU LESEN

- Bitte lesen Sie die Anleitung vor dem Zusammenbau sorgfältig durch.
- Verwenden Sie nur Kunststoffklebstoff und Kunststofflackfarben.
- Die gealterten Plastikteilen sollten zerrissen und weggeworfen werden, um zu verhindern, daß Kleinkinder beim Spielen darin erstickten.
- Handhaben Sie Klebstoff und Lackfarben niemals in der Nähe von offenen Flammen.
- Mit Klebemittel sparsam umgehen und während des zusammenbaus für ausreichende ventilation sorgen

■ANTES DEL ENSAMBLAJE, LEA CUIDADAMENTE LO SIGUIENTE

- Antes del ensamble, estudie cuidadosamente las instrucciones.
- Emplee solamente cemento plástico y pinturas.
- Rompa y tire las bolsas de plástico a fin de evitar que los niños pequeños puedan sofocarse jugando con ellas.
- No emplee nunca cemento ni pintura cerca de flamas.
- Usare l'adesivo moderatamente e ventilare bene l'ambiente durante la costruzione.

■LIRE CECI AVANT D'EFFECTUER LE MONTAGE

- Étudier attentivement les instructions avant le montage.
- N'utiliser que de l'adhésif plastique et du vernis.
- Déchirer et jeter les sacs en plastiques vides pour éviter tout danger d'étouffement pour les enfants.
- Ne jamais utiliser d'adhésif ou du vernis près d'une flamme.
- Utiliser le ciment avec modération et bien ventiler la pièce pendant le montage.

■組立て前務請先看清此說明。

- 請先看清說明圖，把握全體的順序之後才進入組裝。
- 強力膠和塗料請使用塑膠專用的，商品的空袋為了不讓小孩子帶在頭上，請撕掉。
- 強力膠塗料不可在火的附近使用。

■LEGGERE QUESTO PRIMA DEL MONTAGGIO

- Studiare attentamente le istruzioni prima del montaggio.
- Usare solo adesivo e vernici per plastica.
- Strappare e gettare le buste di plastica vuote per evitare il pericolo di soffocamento per bambini piccoli.
- Non usare mai l'adesivo o la vernice vicino ad una fiamma.
- Utilice suficiente adhesivo y ventile bien la habitación durante la construcción.

"WARNING" FUNCTIONAL SHARP POINTS
"WARNUNG" SCHARFE ECKEN UND KANTEN
"Avertissement" Points essentiels de fonctionnement
"ATTENZIONE" PARTI MOLTO ACUMINATE
"AVISO" PUNTOS AGUDOS EN FUNCIONAMIENTO

注意

1. 組み立てモデルです。作る前に組み立て説明書をお読みください。
2. 部品を取り出した後のビニール袋は、小さな子供が頭から被ったり、飲み込んだりすると窒息するおそれがありますので、破り捨ててください。
3. 部品はきれいに切り取り、切り取った後のクズはゴミ箱に捨ててください。
4. 部品はやむやみなくとがっている所がありますので使用目的以外は、絶対に遊ばないでください。特に小さいお子様のいる家庭では注意してください。
5. 小さな部品がありますので、誤って飲み込まないようにしてください。特に小さいお子様のいる家庭では注意してください。
6. 部品の組立の際、ニッパー、ナイフ、ヤスリ等を用意に取り扱うと、刃先等で怪我の恐れがあります。12才以下の方は、保護者の指導のもとに取り扱ってください。
7. 接着剤、塗料を使用する場合は、下記に注意してください。
* 締め切った室内では使用しないでください。中毒の恐れがあります。
* 火の近くでの使用は絶対に止めてください。引火の恐れがあります。接着剤、塗料は目や口に入れないでください。
* 誤って目や口に入ったときは、すぐに大量の水で洗い流して、医師に相談してください。
8. 工具、接着剤、塗料、電池等を使用する場合は、その説明書の注意事項をよく読んで正しく使用してください。

CAUTION

1. THIS BEING AN ASSEMBLY KIT. READ THE INSTRUCTIONS BEFORE ASSEMBLING.
2. TEAR UP AND THROW AWAY THE PLASTIC BAGS CONTAINING KIT PARTS AS CHILDREN MAY SUFFOCATE BY SWALLOWING OR WEARING OVER HEAD.
3. CUT THE PARTS OFF PROPERLY AND THROW THE WASTE PARTS INTO DUSTBOX AT ONCE.
4. DO NOT PLAY WITH THE PARTS FOR ANY OTHER PURPOSE AS SOME PARTS MAY BE TOO SHARP. MORE CAUTION AND CARE NEEDED FOR FAMILIES WITH INFANTS.
5. DO NOT SWALLOW ANY PARTS AND CUT-OFF CHIPS. KEEP AWAY FROM REACH OF CHILDREN.
6. WRONG OR CARELESS USAGE OF NIPPER, CUTTER OR FILE ETC. MAY HURT THE ASSEMBLER.
7. BE CAUTIONS AS FOLLOWS WHEN USING ADHESIVES AND/OR PAINTS:
* DO NOT USE IN CLOSED ROOM TO AVOID POISONING/TOXIC.
* DO NOT USE NEAR FIRE TO AVOID FLAMMABILITY.
* DO NOT PUT ANY ADHESIVES AND/OR PAINTS INTO MOUTH AND EYE IF MISTAKENLY PUT INTO. WASH OUT PROMPTLY WITH FULL WATER AND CONSULT A DOCTOR.
8. USE TOOLINGS, ADHESIVES, PAINTS, BATTERIES ETC. PROPERLY AFTER CAREFUL READING OF INSTRUCTIONS GIVEN IN EACH HANDLING MANUAL.

(株) ハセガワ
静岡県焼津市八橋3-1-2 〒425-8711 TEL (054) 628-8241



HASEGAWA CORPORATION
3-1-2 Yagusu, Yaizu, Shizuoka, 425-8711 Japan.

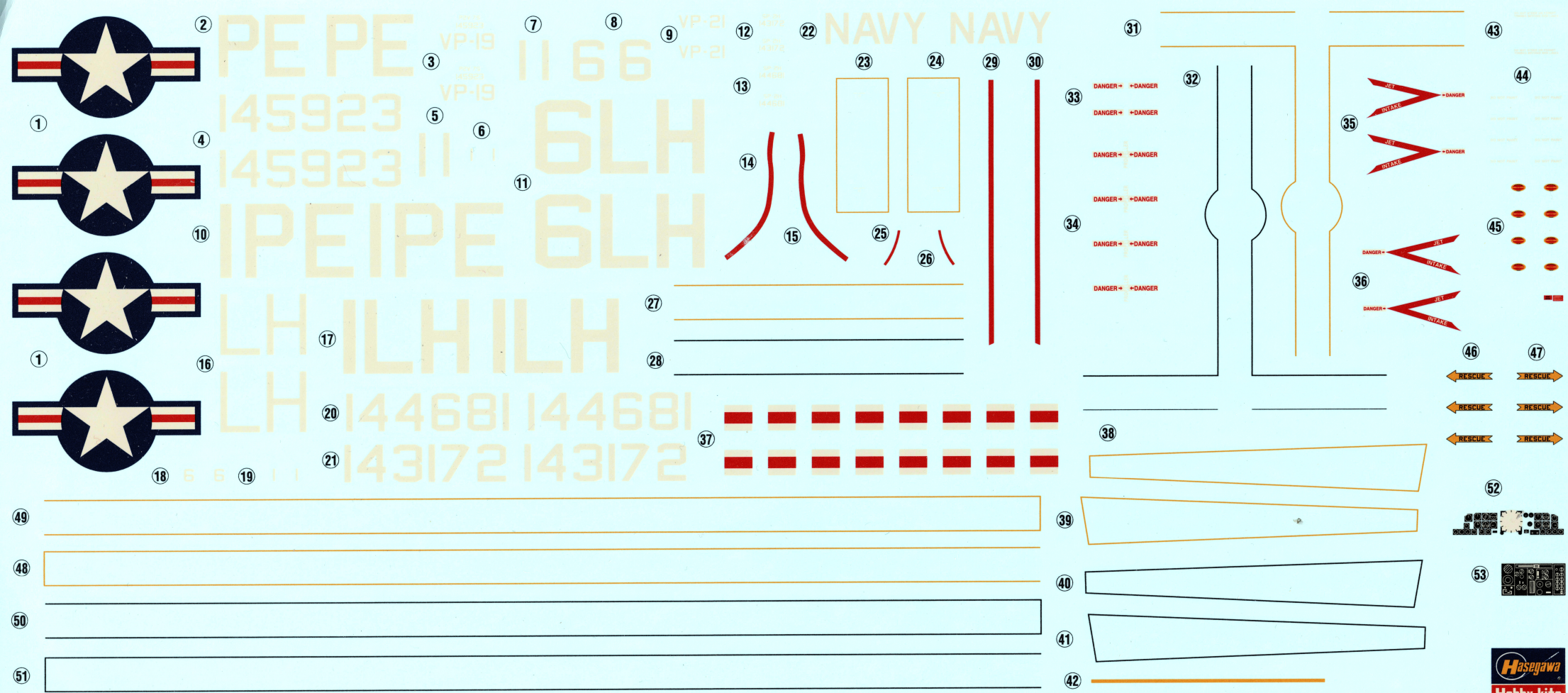

00897 1/72 P2V-7 NEPTUNE "U.S.NAVY" P2V-7 ネプチューン "U.S.ネイビー"