

SOPWITH CAMEL

AIRFIX - 72 SCALE

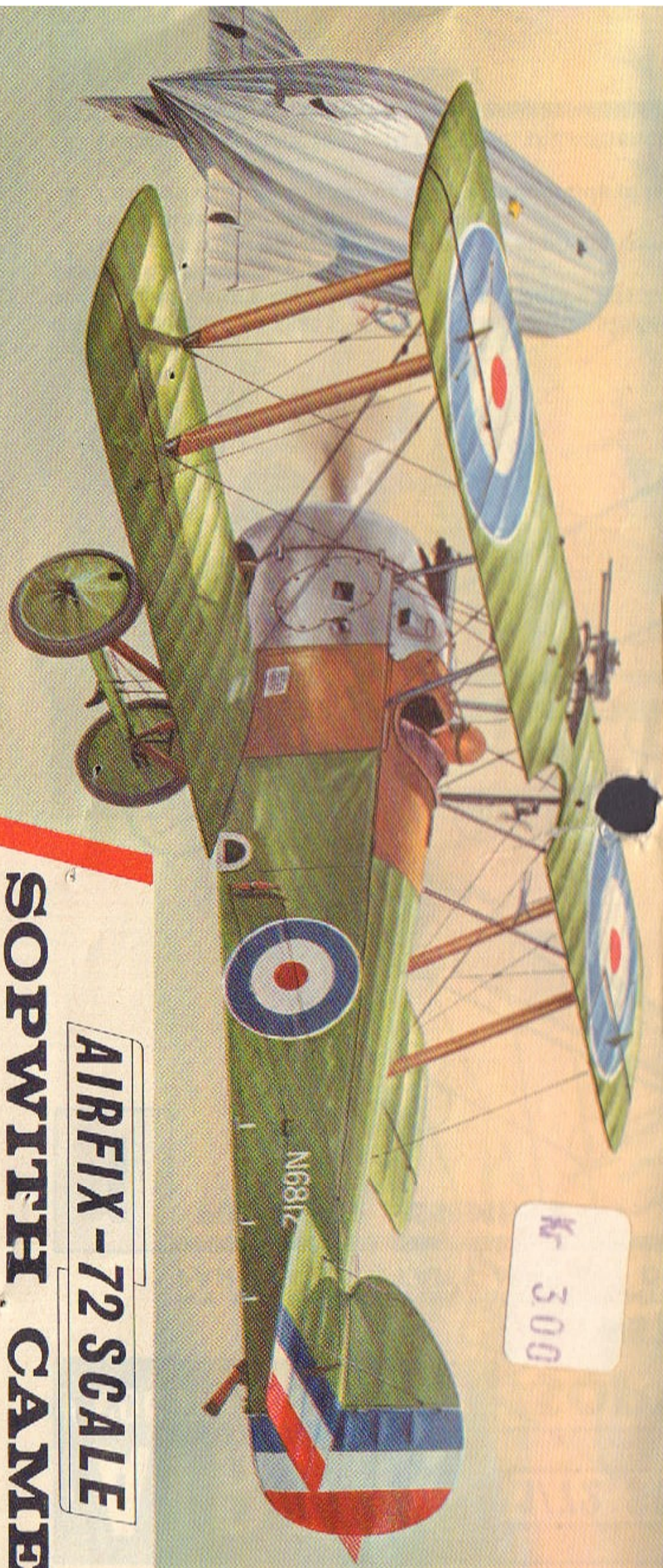

SOPWITH 2F1 CAMEL

The "Camel" was one of the most successful and most popular of all the Allied fighters of the First World War.

Originally introduced in 1916 the "Camel" saw service with both the Royal Flying Corps and the Royal Naval Air Service, and at the close of the war some 2,500 were in use.

The Sopwith 2F1 was the version used mainly by the Royal Naval Air Service, and was distinguished by its 150 h.p. Bentley rotary engine and the armament, consisting of one fixed Vickers machine gun in the fuselage and a Lewis gun on the centre section of the upper wing, instead of the twin Vickers more commonly used by the R.F.C.

An aircraft bearing the same markings as your model was one of the Naval Camels in which Lieut. S. D. Cully destroyed the Zeppelin L53 over the North Sea on 10th August, 1918.

The Camel had a wing span of 26 ft. 11 inches, an overall length of 18 ft. 9 inches, a maximum speed of 120 m.p.h. and a service ceiling of 20,000 ft.

PLEASE OPEN CAREFULLY — INSTRUCTIONS OVERLEAF

AIRFIX

CONSTRUCTION KIT

1/72 SCALE MODEL CONSTRUCTION KIT

SOPWITH 2FI CAMEL

INSTRUCTIONS

N.B. FOR PAINTING USE "AIRFIX" PAINTS, FOR FIXING USE "AIRFIX" POLYSTYRENE CEMENT
PAINT ALL DETAILS AND LET DRY BEFORE ASSEMBLING (SEE SECTION 4)

1 FUSELAGE ASSEMBLY

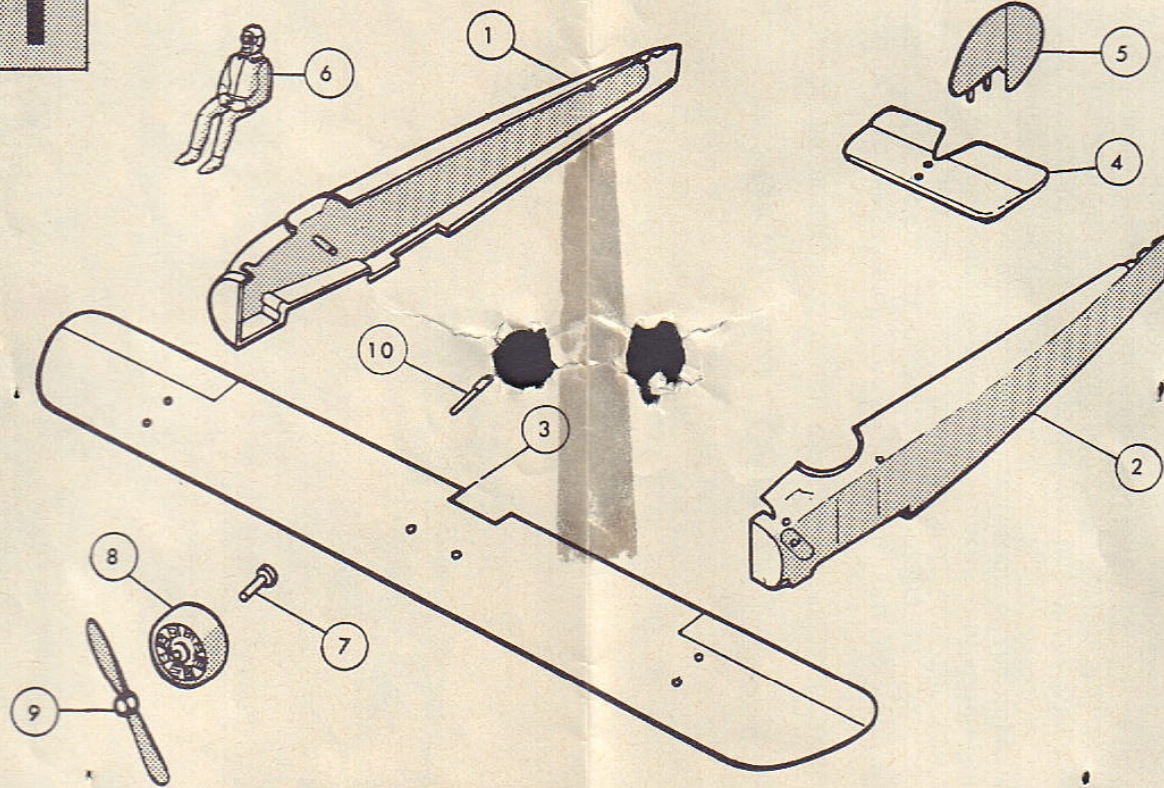

It is recommended that the instructions and exploded view are studied before assembly. Note that some parts are best painted before assembly.

1. Cement together fuselage halves by applying cement to the inside edges of fuselage (1 and 2).
2. Position and cement lower wing to underside of fuselage (3).
3. Locate and cement tailfin to tailplane, and cement assem-

- bly in position on rear fuselage (4 and 5).
4. Cement pilot in position on support provided (6).
5. Insert propeller shaft through engine unit and cement into rear of propeller, ensuring no cement comes into contact with the engine (7, 8, 9).
6. When dry cement engine onto front fuselage.
7. Cement Vickers machine-gun to front fuselage, introducing the rear of the gun into the slot in the fuselage (10).

2 WING ASSEMBLY

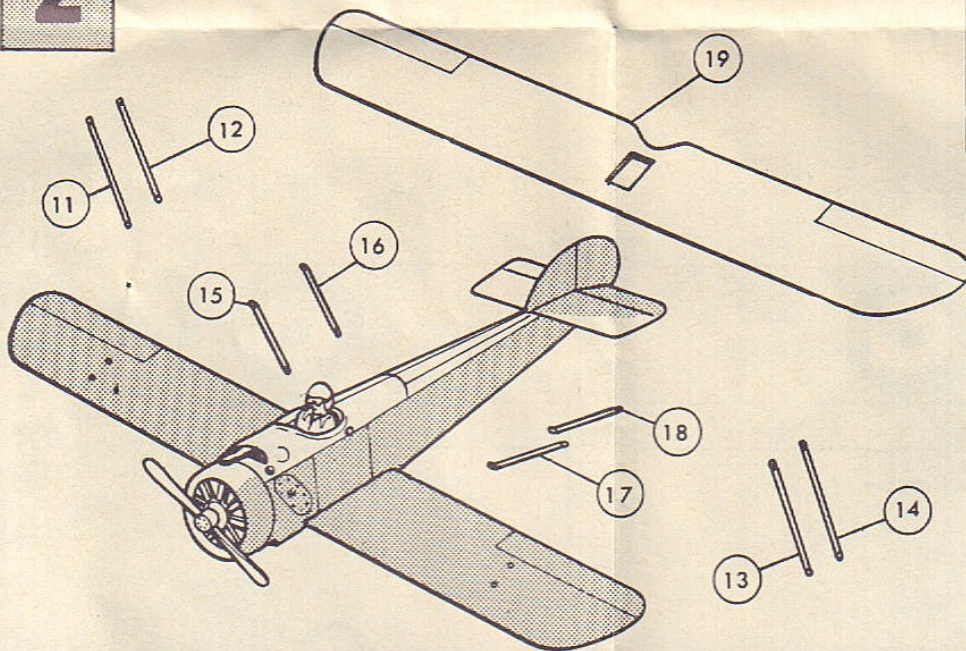

8. Cement in position interplane struts to locations in lower wing, ensuring the struts are raked forward (11, 12, 13 and 14).
9. Locate and cement centre section struts into locations on fuselage, the front struts vertical and the rear struts raked forward (15, 16, 17, 18).
10. Before the struts are firmly set, affix the top wing, by applying cement to the strut locations in the wing, ensure the wings are correctly aligned and set aside to dry (19).

3 UNDERCARRIAGE ASSEMBLY

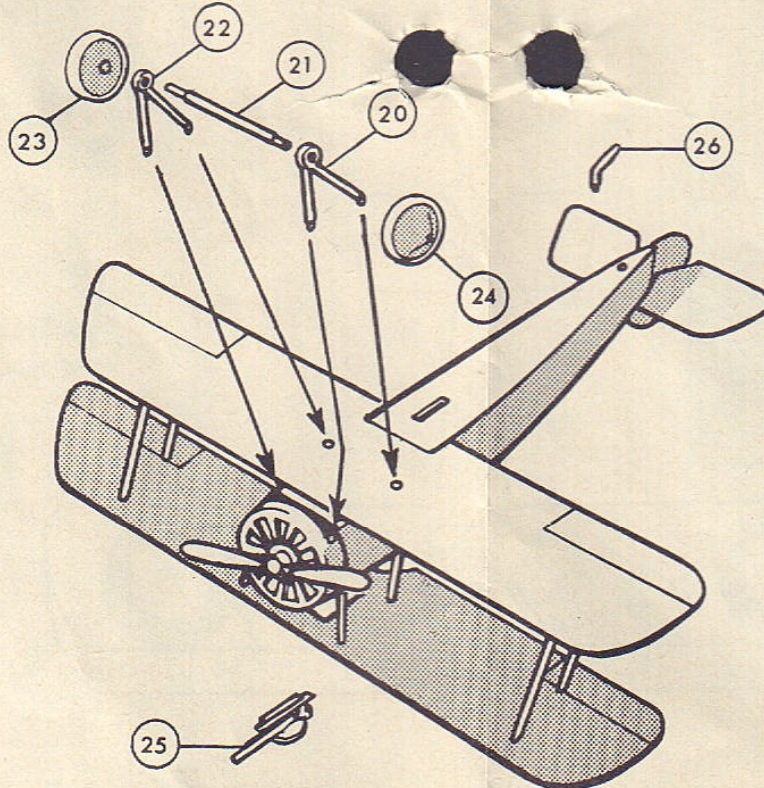

11. Cement starboard undercarriage leg in position, insert axle, then cement port undercarriage leg in position over axle (20, 21 and 22).
 12. Cement wheels in position onto protruding ends of axle (23 and 24).
 13. Cement Lewis gun and supporting strut centrally across slot in top wing (25).
 14. Locate and cement tailskid into hole in underside of fuselage (26).
- NOTE.—IF IT IS WISHED TO PAINT THE MODEL IT SHOULD BE DONE AT THIS STAGE.**
15. Cement together both parts of stand.
 16. Cement arm of stand into slot provided in fuselage.

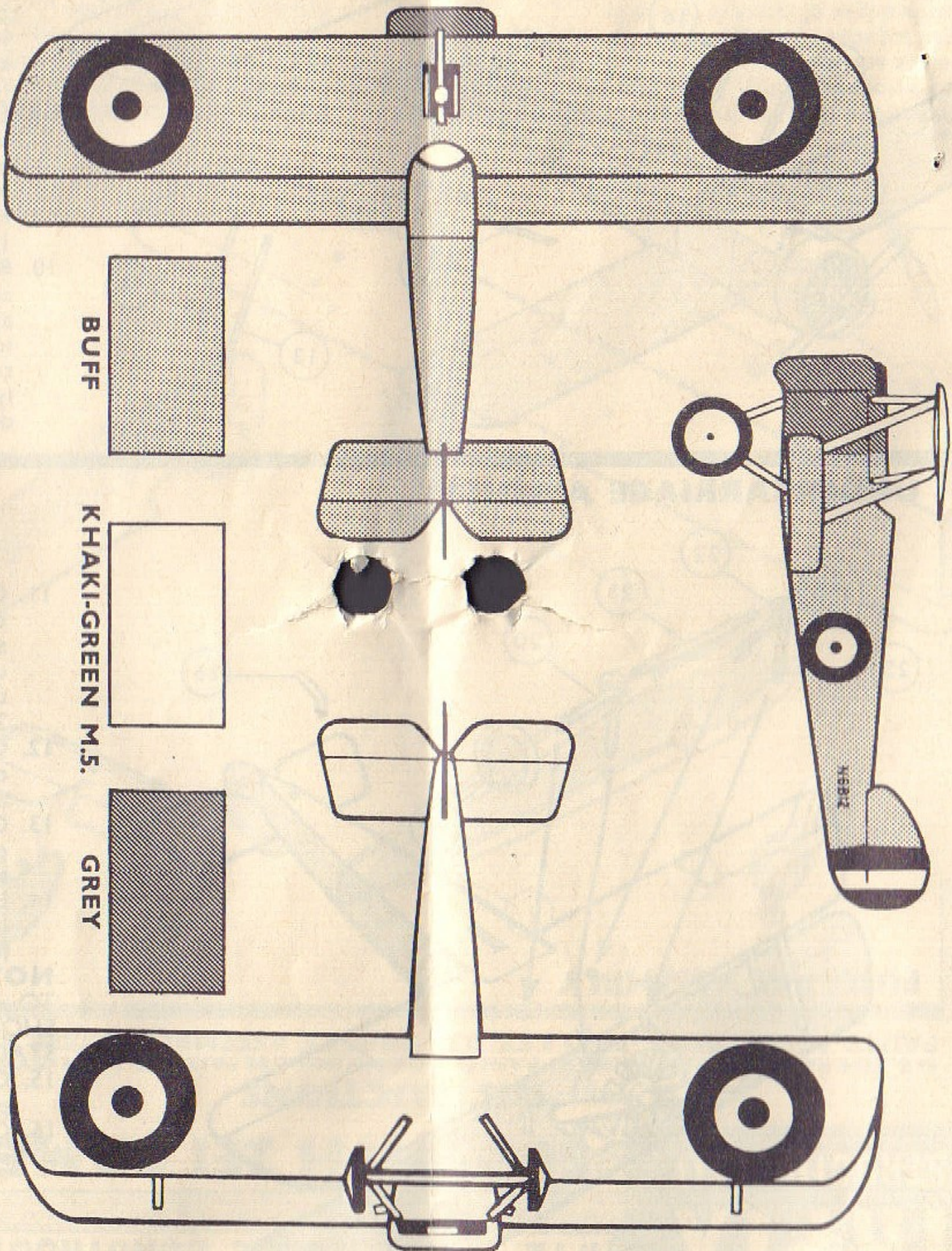

17. Apply transfers. First cut the sheet into 11 separate subjects. Then dip each in warm water for a few minutes, slide transfer into position as indicated on illustration. The large roundels are applied to the top of the upper and bottom of lower wings. The small roundels are applied to the fuselage sides, the fin flashes to the fin (blue forward) and the serial numbers to the fuselage sides. The aircraft name is applied to the transparent base.

BUFF Under surfaces of top and bottom wings and tailplane.
GREY Engine cowling and fuselage in front of leading edge of lower wing.
KHAKEI-GREEN M.5. Upper surfaces top and bottom wings and tailplane, all fuselage behind leading edge of lower wing, fin, undercarriage legs, axle, wheel discs and struts.
BLACK Tyres, engine cylinders, tailskid, machine-guns and propeller.