

# Painting and marking

1. Sikorsky S-51, ex PH-HAA  
8.sqn. of Royal Netherlands  
Navy, Valkenburg AB, 1953,  
The Netherlands

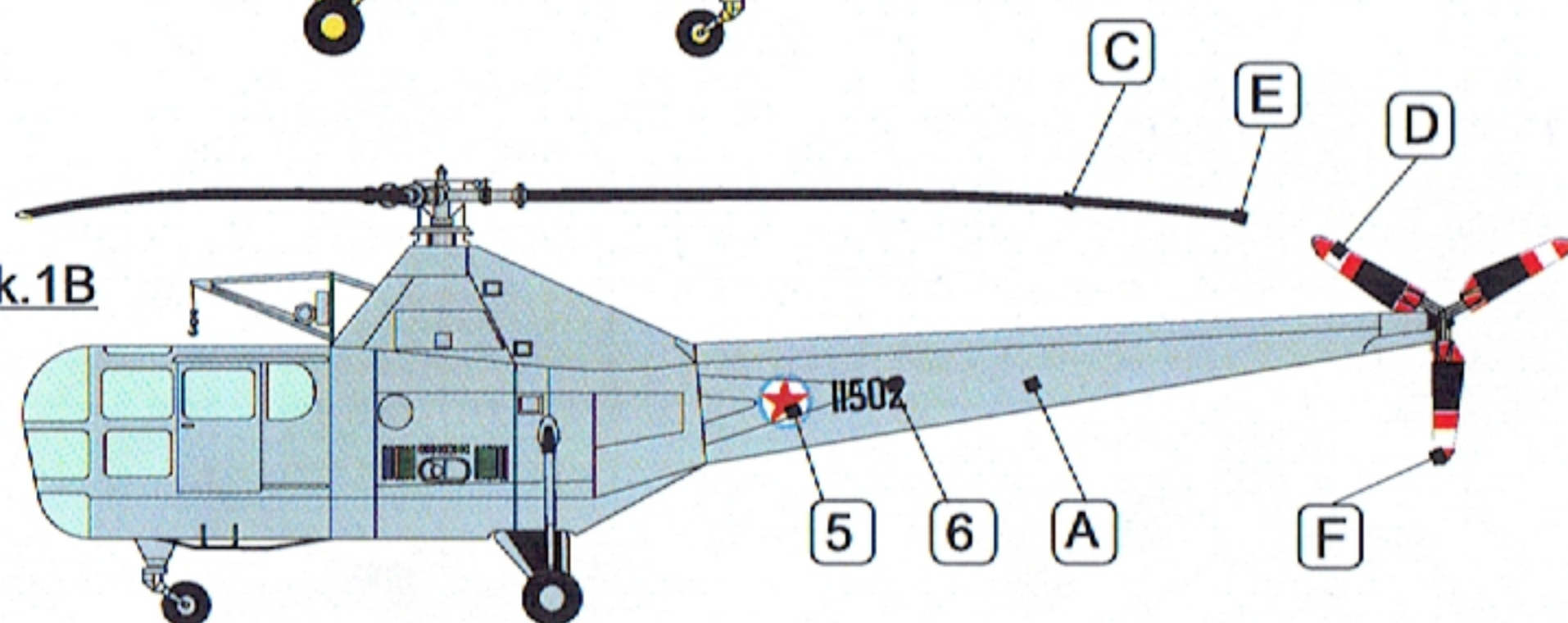

2. Westland Sikorsky S-51 Mk.1B  
5th Helicopter Escadrille of  
119th Transport Group,  
Yugoslav Air Force, 1954,  
Yugoslavia

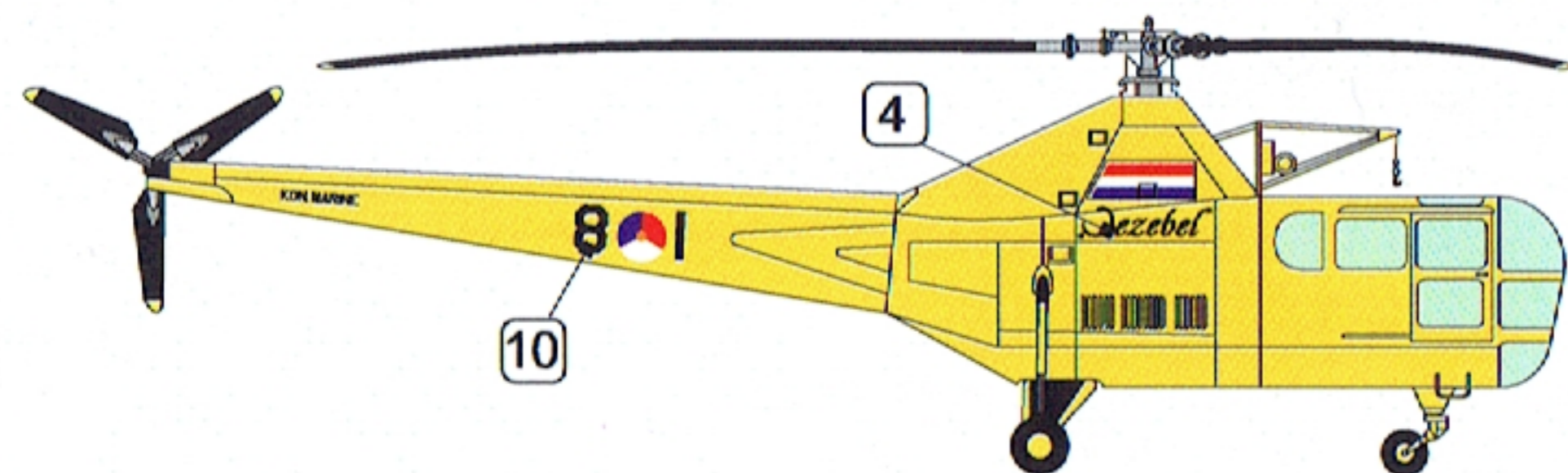
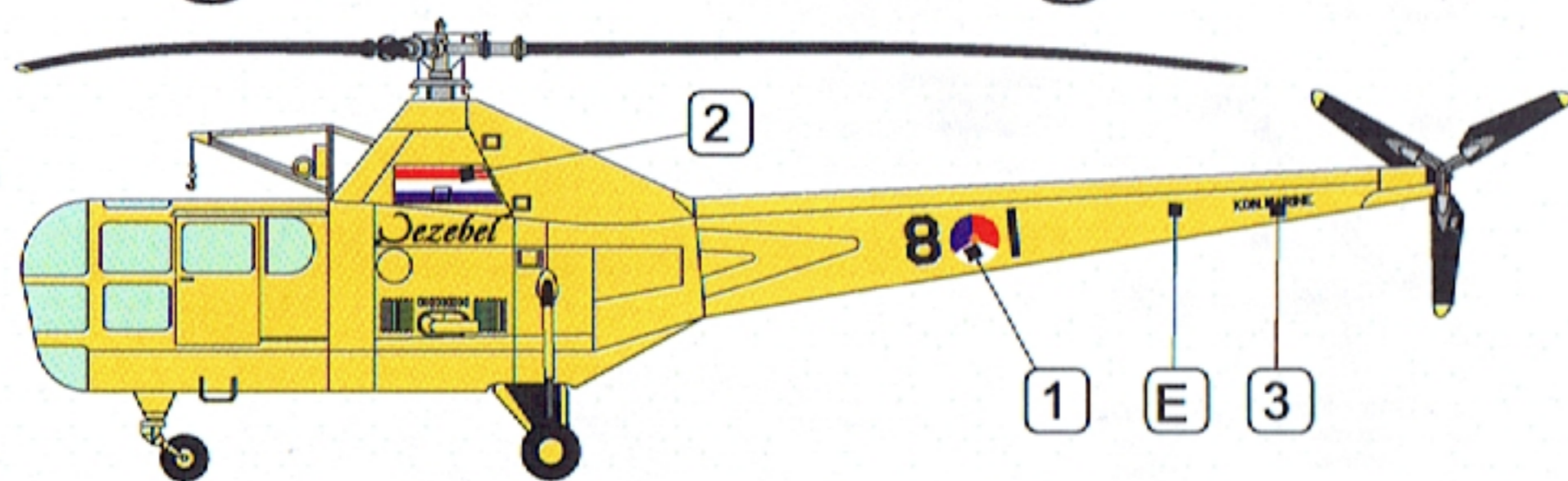
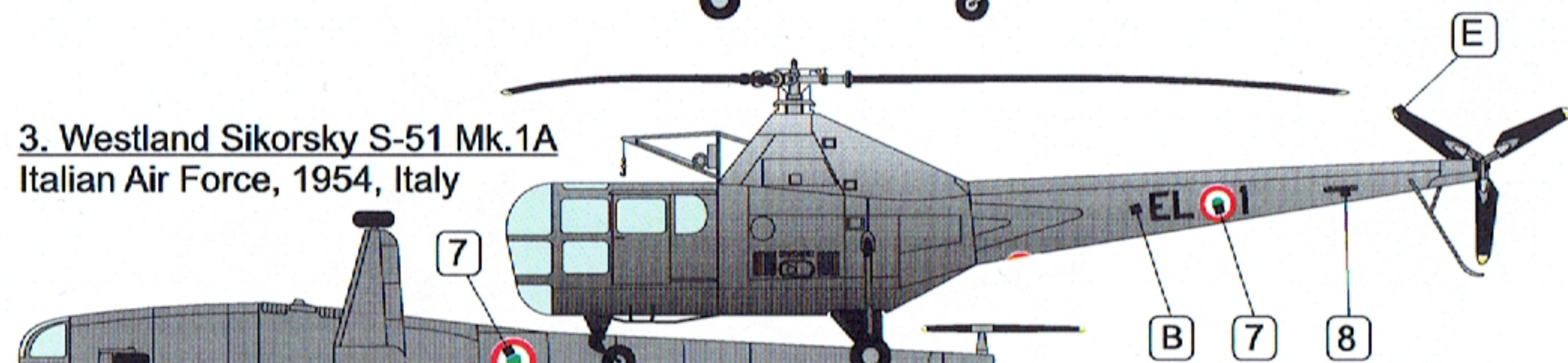
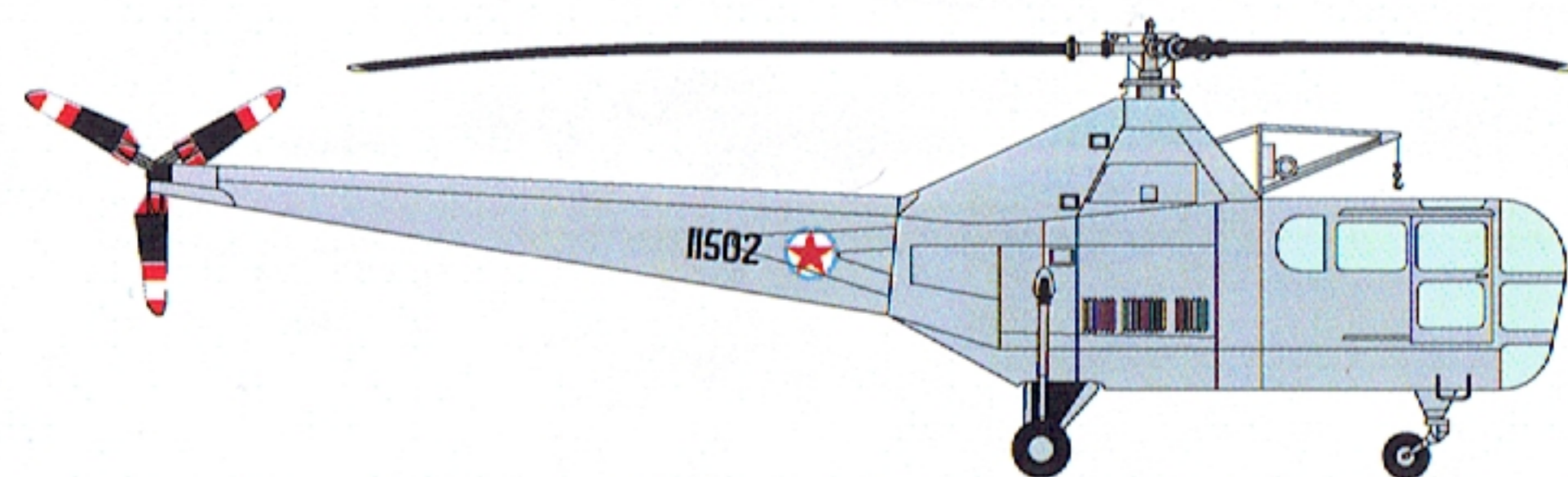

3. Westland Sikorsky S-51 Mk.1A  
Italian Air Force, 1954, Italy

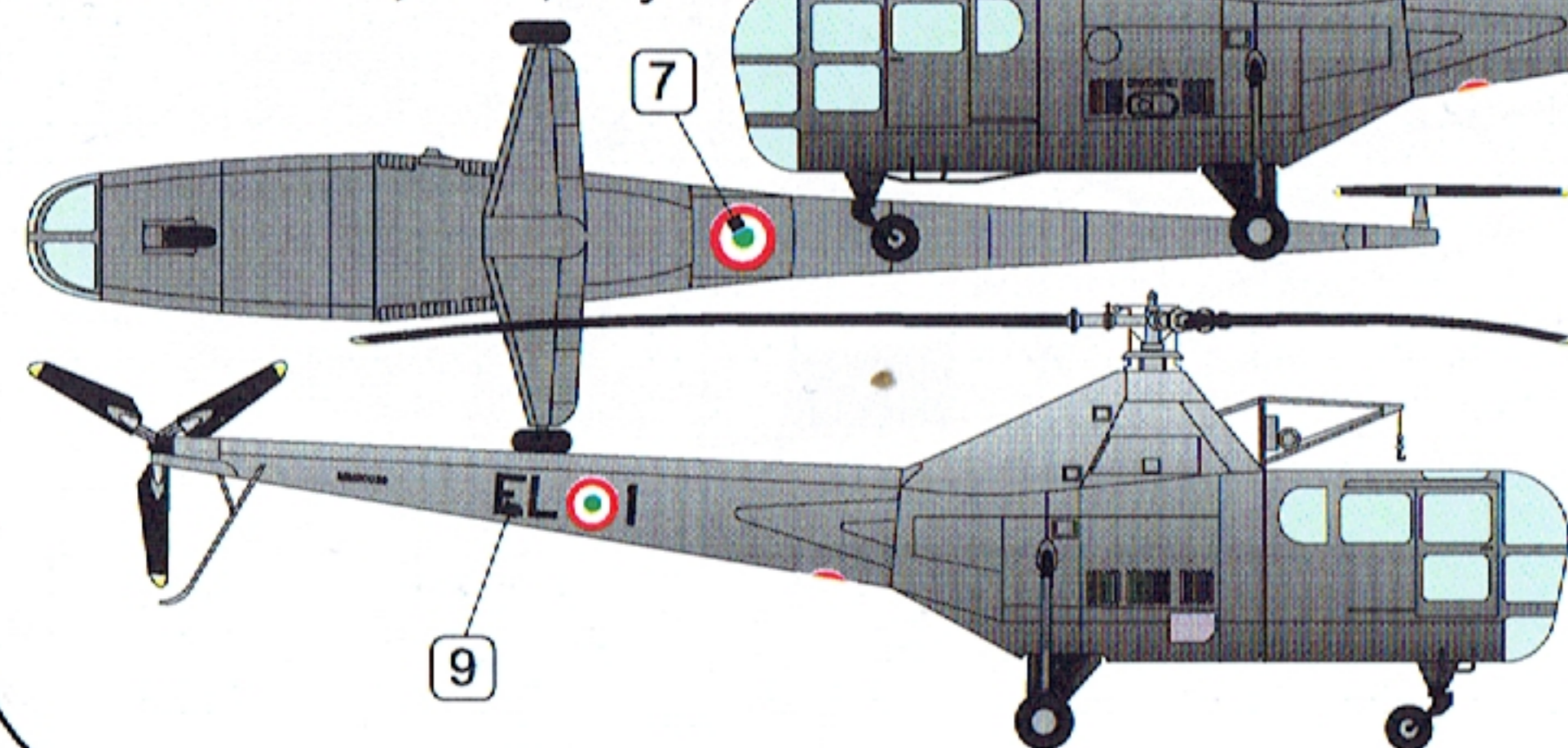

LF  
MODELS

Plastic edition

# SIKORSKY S-51 DRAGONFLY MK.IA/B

KIT NO. PE7230

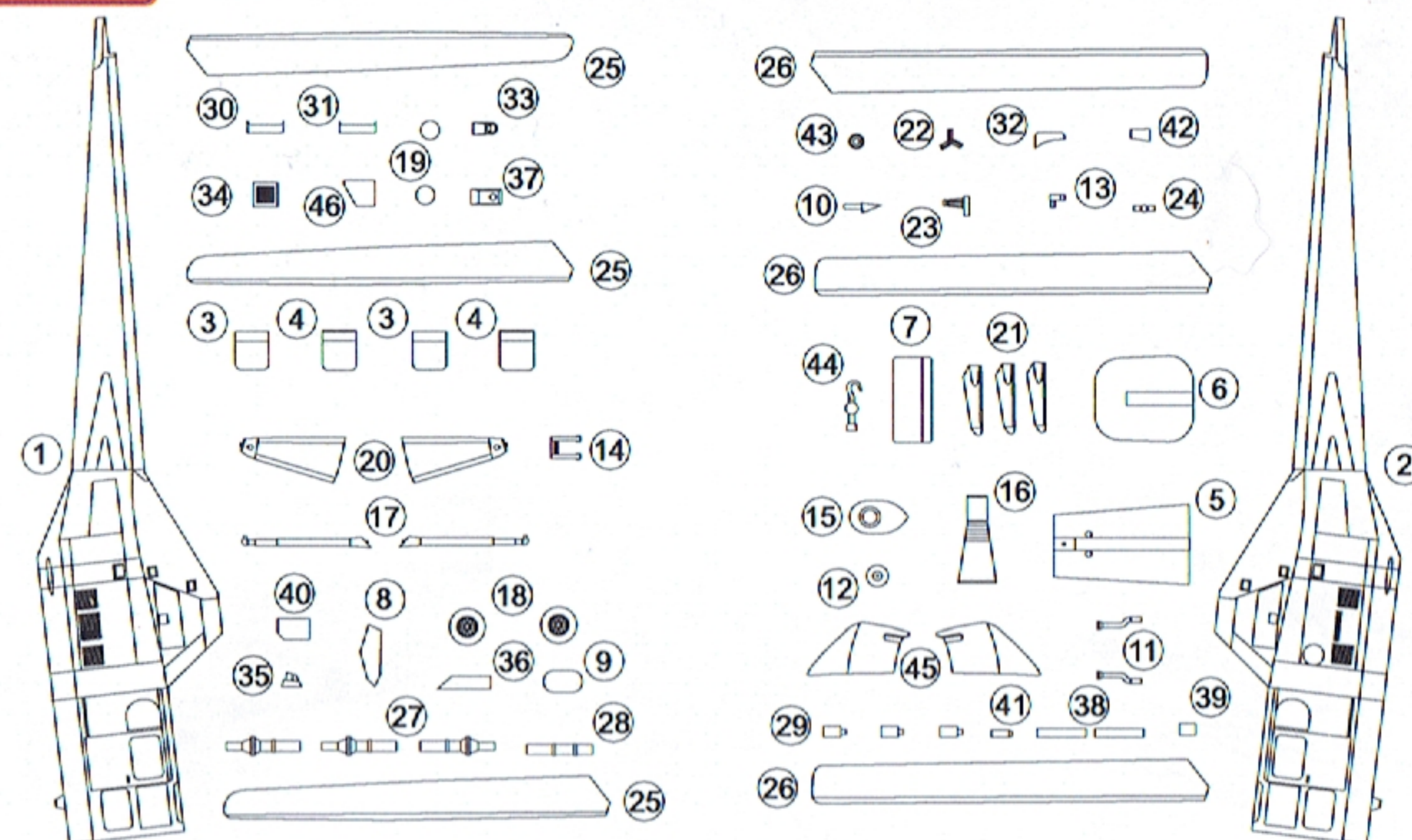

Kabina  
Canopy

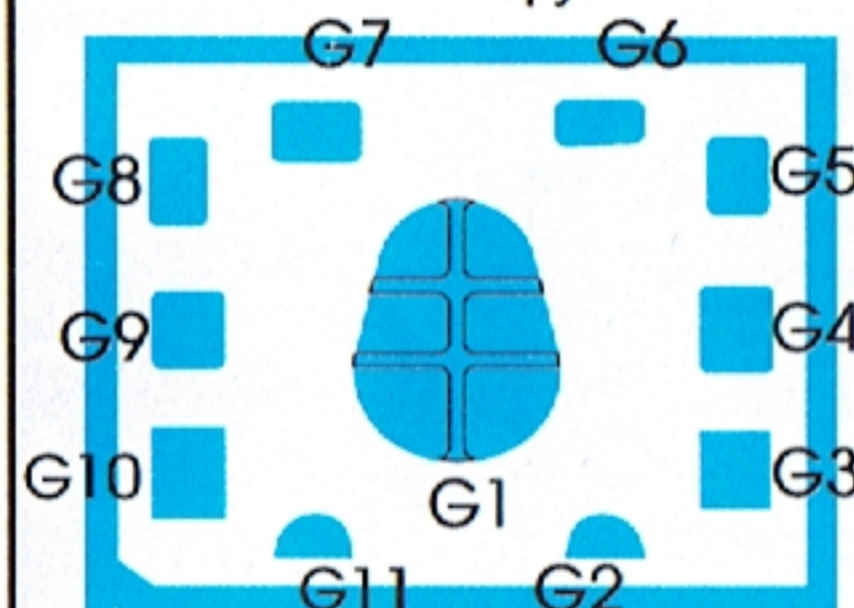

Leptané díly  
Photo-etched parts

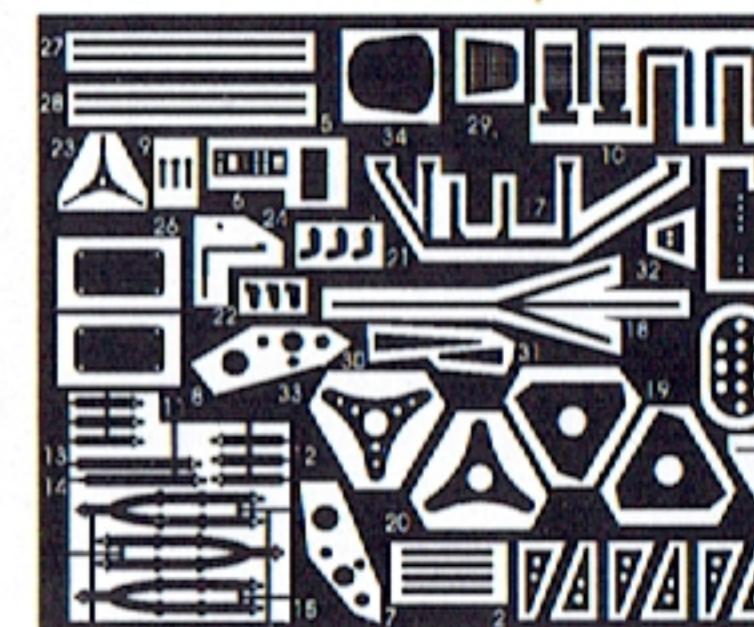

Obtisky / decals

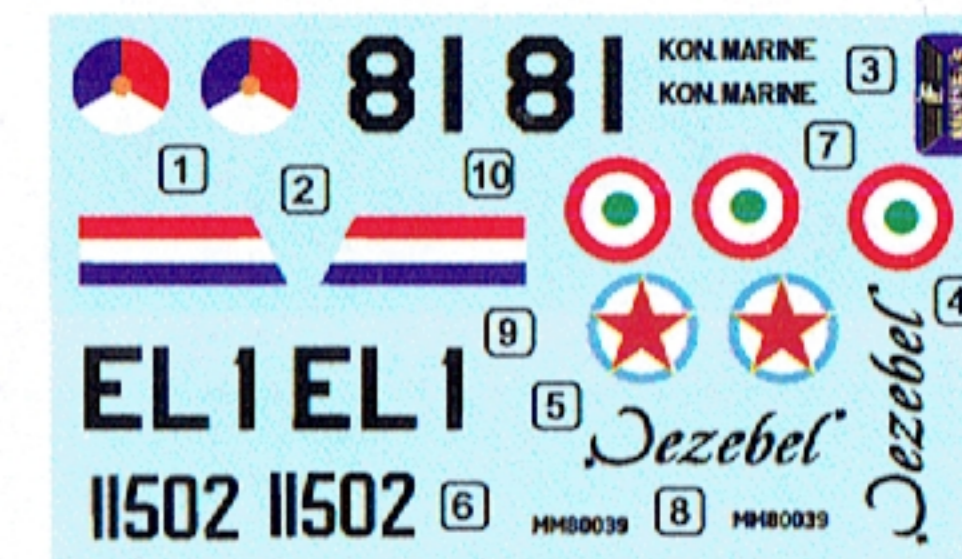

Palubní deska  
Instrument panel

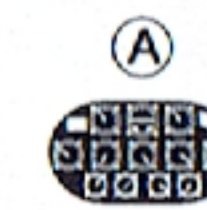

- Barvy / Colours [AK Real Colors]
- |   |                   |   |               |   |                |
|---|-------------------|---|---------------|---|----------------|
| A | Pale Blue / RC017 | C | Black / RC001 | E | Yellow / RC007 |
| B | Aluminium / RC020 | D | White / RC004 | F | Red / RC005    |

První zkušební let vrtulníku pod označením XR-5 proběhl 18.8.1943. Vrtulníky byly nasazovány na obslužné, záchranné a humanitární mise po celém světě, včetně letů na Antarktidě, především však k záchraňování spojeneckých pilotů sestřelených nad nepřátelským územím a evakuaci raněných z frontových oblastí. Nejrozšířenějším typem byla verze H-5G a HO3S-1. V roce 1951 byla výroba ukončena po vyrobení více jak 300 kusů všech modelů tohoto vrtulníku.

Specifikace:

Délka:17,4m; Průměr rotoru:14,63m; Výška :3,96m; Nejvyšší rychlost: 171km/h; Dolet: 580km; Dostup: 4390m.

The first test flight under the designation XR-5 took place on August 18, 1943. Helicopters were deployed on service, rescue and humanitarian missions around the world, including flights over Antarctica, primarily to rescue Allied pilots shot down over enemy territory and evacuate wounded from front line areas. The most widespread type was H-5G and HO3S-1. Production was discontinued after production of more than 300pcs of all models of this helicopter in 1951.

Specification:

Length:17,4m; Rotor diameter: 14,63m; Height :3,96m; Top speed: 171km/h; Range: 580km; Ceiling: 4390m.

LF Models, Ladislav Fojtl, Nový Malín 711, 788 03 Nový Malín, Czech Republic  
www.lfmodels.com, e-mail: lfmodels@lfmodels.com, mobile:+420-776326833

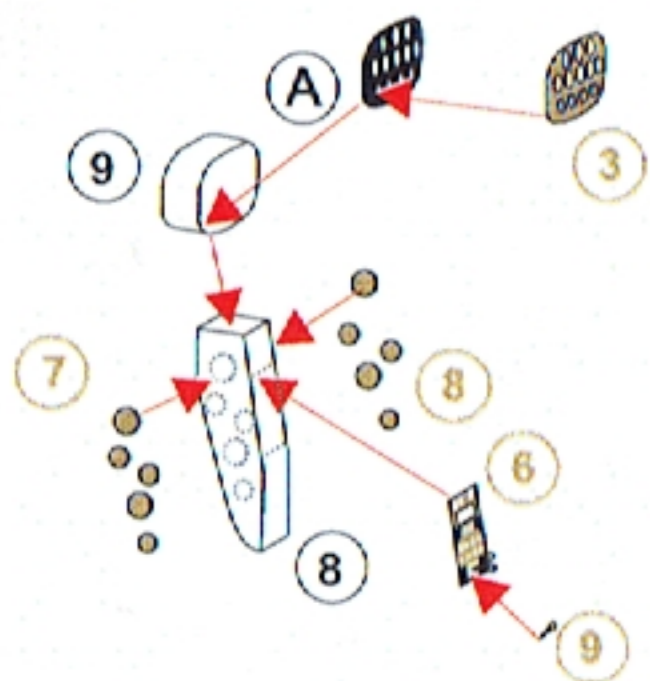
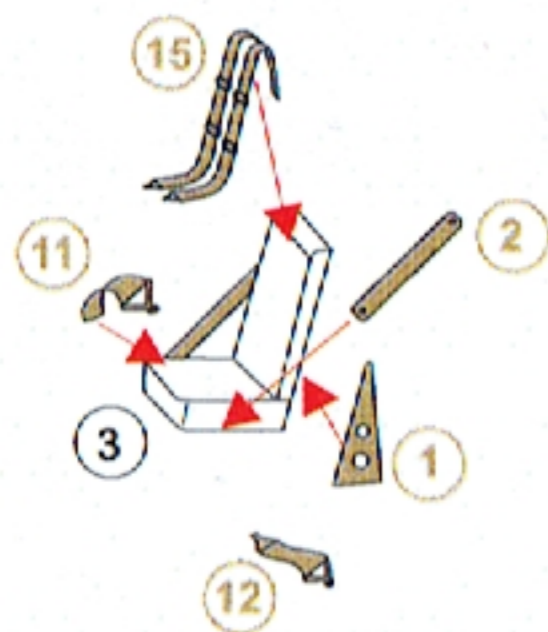
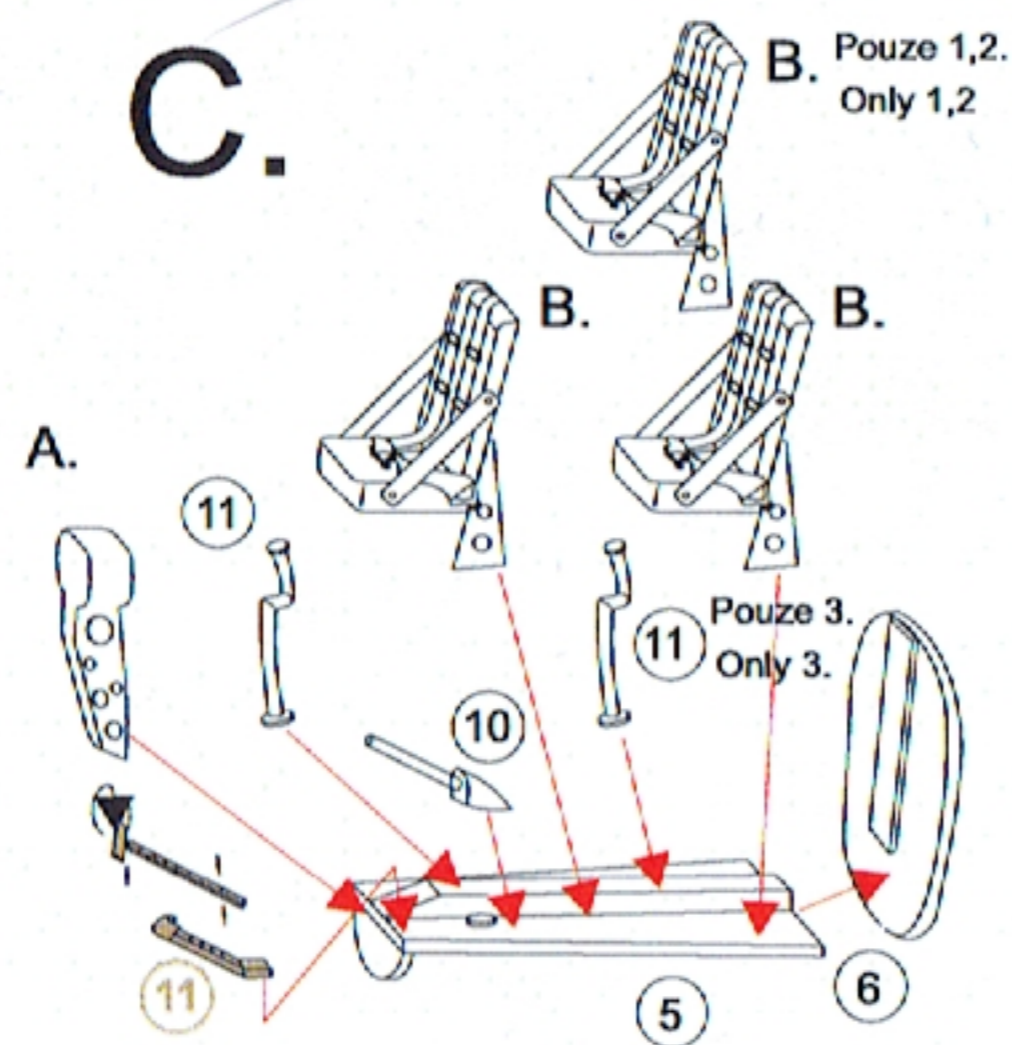
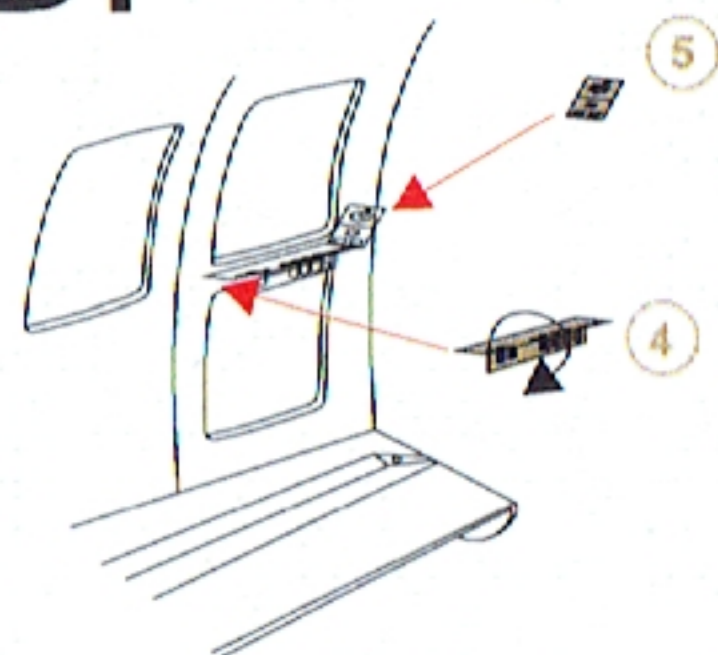
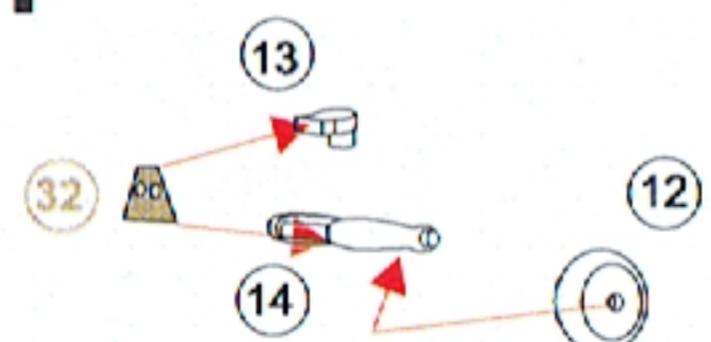
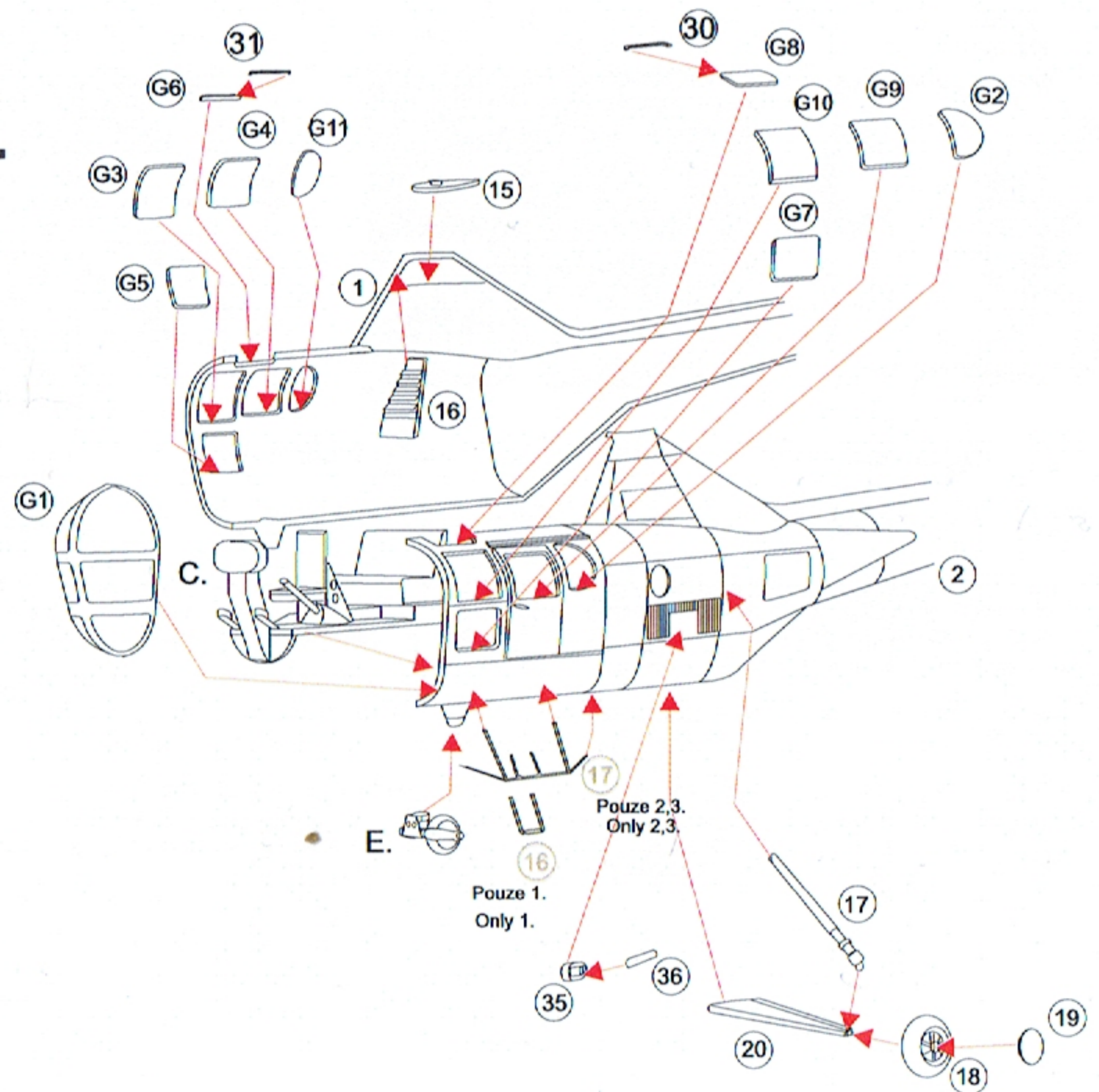
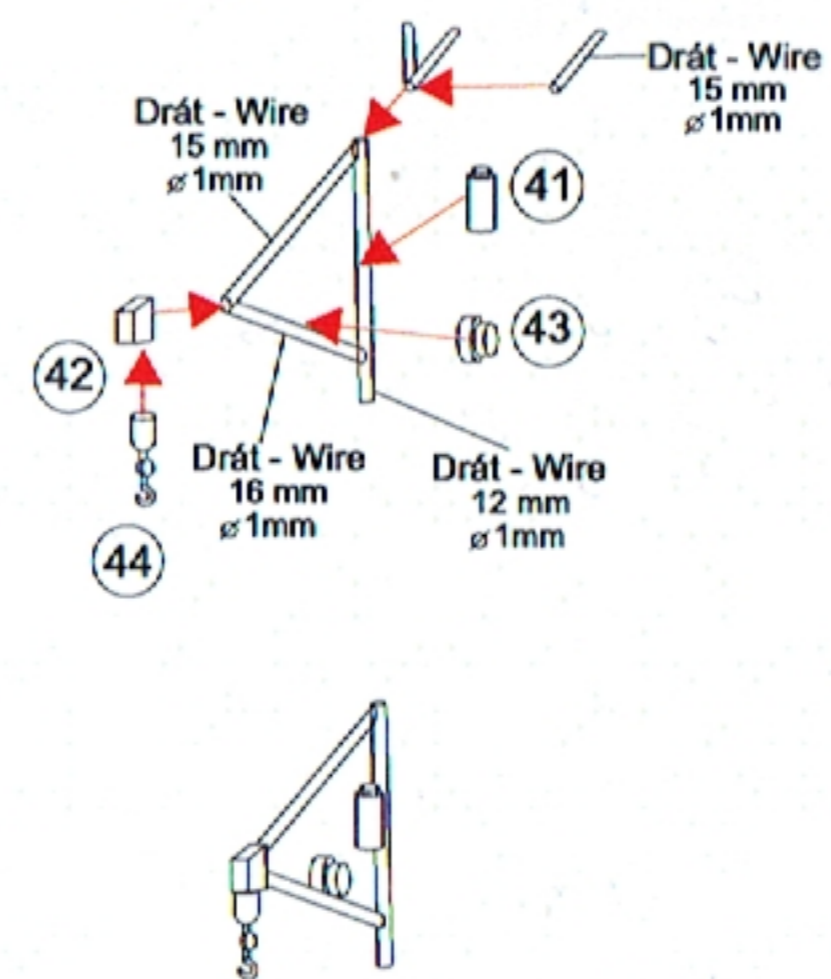
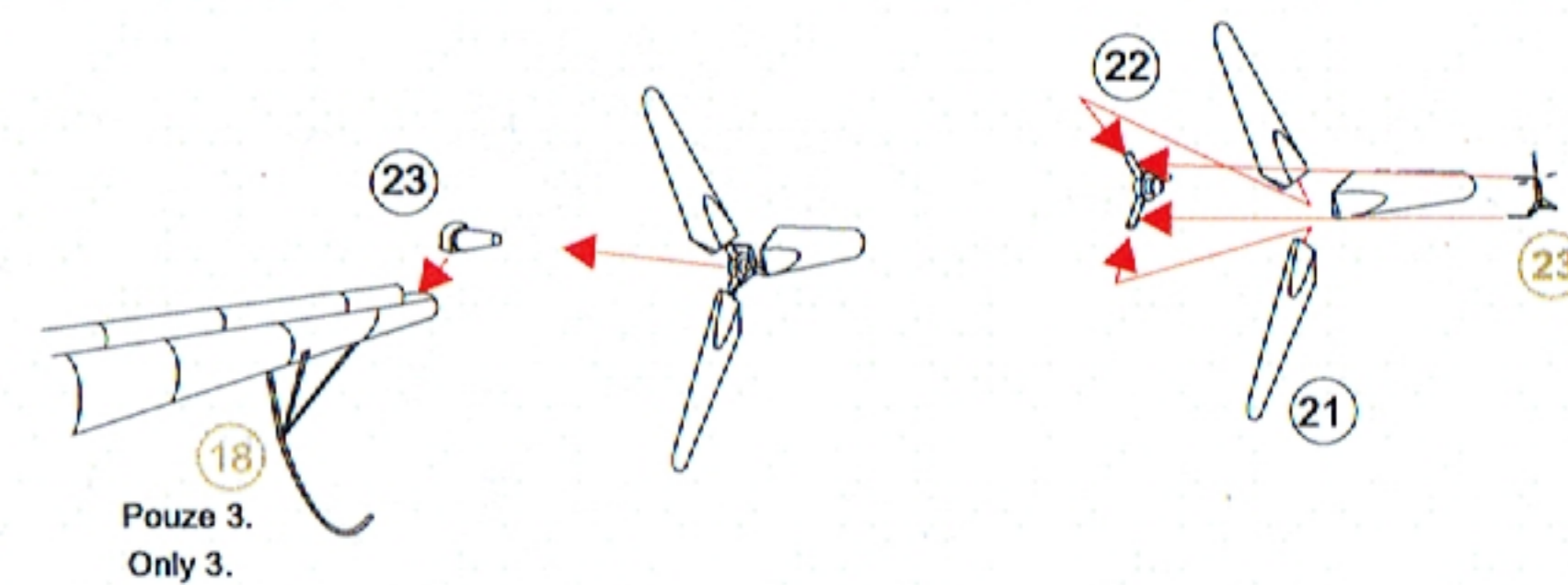
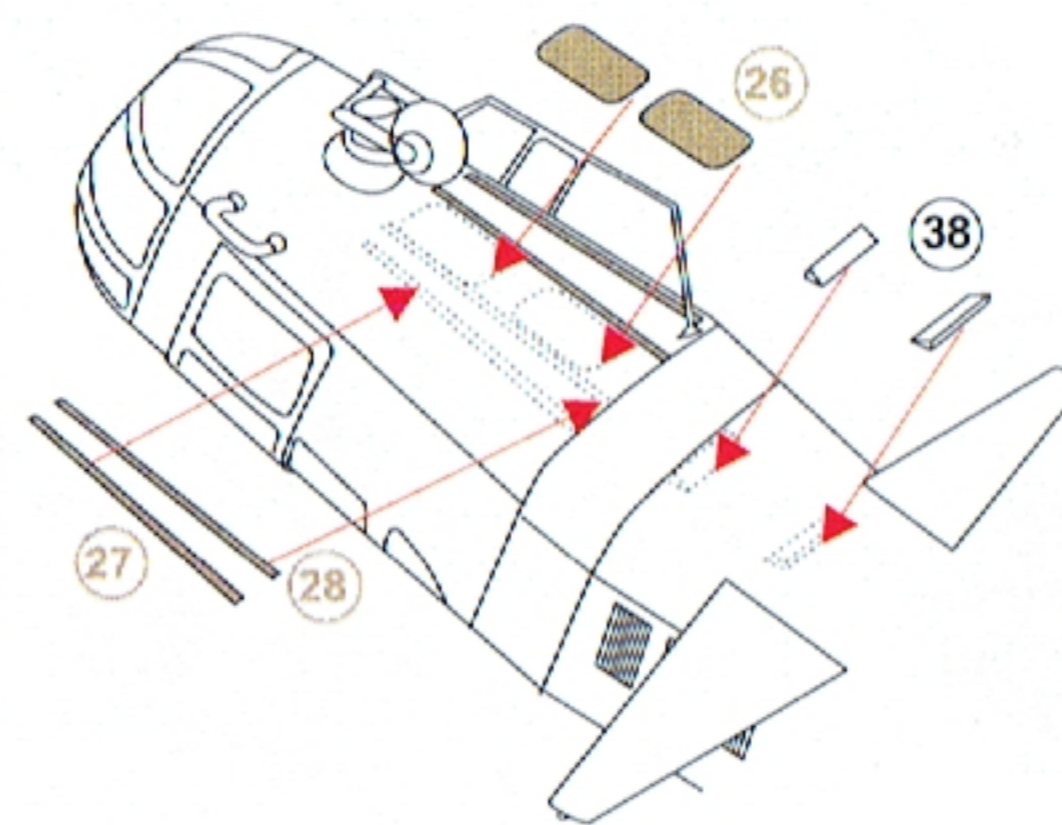

**A.****B.****C.****D.****E.****F.****G.****H.****I.****J.**