

Made in Italy

1:72 scale

No 1462

# Stirling Mk. III

EN

The Short Stirling was the first four-engined British heavy bomber of the Second World War. The design had high wing, four engines and the cabin elevated over the fuselage. The airframe was fully made in metal. Another feature that characterised the bomber was the impressive size of the landing gears. The first bombers went to equip the Royal Air Force Bomber Command Squadrons from the end of 1940. The Operational status was reached on January 1941 and the first war mission was dated February 1941 against logistic installation in Rotterdam. Stirling Mk. I was able to carry a significant offensive load of over 6,000 Kg of bombs and was armed with eight 7.7 mm machine guns for defence. The direct successor of the Mk.I version was the Mk.III, fitted with new and improved Bristol Hercules XVI engines and enhanced defensive armaments.

IT

Lo Short Stirling è stato il primo bombardiere pesante britannico ad entrare in servizio durante la seconda guerra mondiale. Il progetto dello Stirling si caratterizzava per l'ala alta, i quattro motori e la cabina sopraelevata rispetto alla fusoliera. La struttura del velivolo era interamente metallica. Altra caratteristica dello Stirling era il grande carrello di atterraggio. I primi Stirling Mk I andarono ad equipaggiare i reparti del Bomber Command della R.A.F. a partire dalla fine del 1940. La prima missione operativa, contro installazioni industriali a Rotterdam, venne realizzata nel 1941. Lo Stirling aveva la possibilità di trasportare un significativo carico offensivo di oltre 6.000 Kg di bombe ed era armato con 8 mitragliatrici da 7,7 mm per la difesa. La diretta evoluzione del Mk.I fu la versione Mk.III con nuovi motori Bristol Hercules XVI potenziati ed un migliore armamento difensivo.

DE

Der Short Stirling war der erste schwere britische Bomber, der während des zweiten Weltkriegs eingesetzt wurde. Bei dem Projekt des Stirling handelte es sich um einen viermotorigen Hoch Decker mit hinsichtlich zum Rumpf erhöhten Kabine. Die Struktur des Flugzeugs bestand vollständig aus Metall. Eine weitere Eigenschaft der Stirling war das große Fahrwerk. Die ersten Stirling Mk I rüsteten ab Ende 1940 die Abteilungen der Bomber Command der R.A.F. aus. Der erste Einsatz wurde 1941 gegen Industrieanlagen in Rotterdam geflogen. Die Stirling konnte eine große Bewaffnungslast von mehr als 6.000 kg Bomben transportieren und war zur Verteidigung mit acht 7,7-mm-MGs ausgerüstet. Die direkte Weiterentwicklung der Mk.I war die Mk.III-Version mit neuen, verbesserten Bristol Hercules XVI-Motoren und verbesserter Abwehrbewaffnung.

FR

Le Short Stirling a été le premier bombardier lourd britannique à entrer en service pendant la seconde guerre mondiale. Le projet du Stirling était caractérisé par l'aile haute, les quatre moteurs et la cabine surélevée par rapport au fuselage. La structure de l'avion était entièrement métallique. Une autre caractéristique du Stirling était son grand train d'atterrissage. Les premiers Stirling Mk I allèrent équiper les compagnies du Bomber Command de la RAF dès la fin de 1940. La première mission opérationnelle, contre les installations industrielles à Rotterdam, eut lieu en 1941. Le Stirling avait la capacité de transporter une charge offensive significative de plus de 6 000 kg de bombes et était armé de 8 mitrailleuses de 7,7 mm pour la défense. L'évolution directe du Mk.I fut la version Mk.III avec de nouveaux moteurs Bristol Hercules XVI améliorés et un armement défensif amélioré.

ES

El Short Stirling ha sido el primer bombardero de gran porte británico que se ha puesto en servicio durante la segunda guerra mundial. El proyecto del Stirling se caracterizaba por el ala alta, los cuatro motores y la cabina elevada respecto al fuselaje. La estructura de la aeronave era completamente metálica. Otra característica del Stirling era el gran tren de aterrizaje. Los primeros Stirling Mk I entraron a formar parte de las divisiones del Bomber Command de la R.A.F. a partir del final de 1940. La primera misión operativa, contra instalaciones industriales en Rotterdam, se realizó en 1941. El Stirling era capaz de transportar una carga importante ofensiva de más de 6.000 kg de bombas y estaba armado con 8 ametralladoras de 7,7 mm para la defensa. La evolución directa del Mk.I fue la versión Mk.III con nuevos motores Bristol Hercules XVI con mayor potencia y un mejor armamento defensivo.

RU

Short Stirling был первым британским тяжёлым бомбардировщиком, который вошёл в эксплуатацию во время Второй Мировой Войны. Проект Stirling отличался высоким крылом, четырьмя двигателями и кабиной, надстроеной над фюзеляжем. Самолёт был полностью сделан из металла. Другой характеристикой Stirling было большое шасси. Первые Stirling Mk I снабжали всем необходимым подразделения бомбардировочного авиационного командования R.A.F. начиная с 1940 года. Первая оперативная миссия против промышленных установок в Роттердаме была исполнена в 1941 году. Stirling мог перевозить значительный боевой груз более 6 000 кг бомб и был вооружён 8 пулемётами 7,7 мм для защиты. Усовершенствованным вариантом Mk.I стала версия Mk.III с новыми усиленными двигателями Bristol Hercules XVI и улучшенным защитным вооружением.



- EN **WARNING:** Model for adult collector age 14 and over
- IT **ATTENZIONE:** Modello per collezionisti adulti di età superiore ai 14 anni
- FR **ATTENTION:** Modèle pour modélistes de 14 ans et plus.
- DE **ACHTUNG:** Modellbausätze Für Modellbauer über 14 Jahre.
- NL **WAARSCHWING:** Geschikt voor 14 jaar en ouder.
- ES **ATENCION:** Modelo para modelistas mayores de 14 años.

**EN ATTENTION - Useful advice!**

STUDY THE INSTRUCTIONS CAREFULLY PRIOR TO ASSEMBLY. REMOVE PARTS FROM FRAME WITH A SHARP KNIFE OR A PAIR OF SCISSOR AND TRIM AWAY EXCESS PLASTIC. DO NOT PULL OIL PARTS. ASSEMBLE THE PARTS IN NUMERICAL SEQUENCE. USE PLASTIC CEMENT ONLY AND USE CEMENT SPARINGLY TO AVOID DAMAGING THE MODEL. BLACK ARROWS INDICATE PARTS TO BE GLUED TOGETHER. WHITE ARROWS INDICATE ON WHICH FRAME THE PARTS MUST BE ASSEMBLED WITHOUT USING CEMENT. THESE LETTERS (A - B - C...) INDICATE ON WHICH FRAME THE PARTS WILL BE FOUND. PAINT SMALL PARTS BEFORE DETACHING THEM FROM FRAME. REMOVE PAINT WHERE PARTS ARE TO BE CEMENTED. CROSSED OUT PARTS MUST NOT BE USED.

**IT ATTENZIONE - Consigli utili!**

PRIMA DI INIZIARE IL MONTAGGIO STUDIARE ATTENTAMENTE IL DISEGNO. STACCARE CON MOLTA CURA I PEZZI DALLE STAMPATE, USANDO UNA TAGLIA-BALSA OPPURE UN PAIO DI FORBICI E Togliere con una piccola lama o con carta vetro fine eventuali sbavature. Mai staccare i pezzi con le mani. Montarli seguendo l'ordine delle numerazioni delle tavole. Eliminare dalla stampata il numero del pezzo appena montato facendogli sopra una croce. Le frecce nere indicano i pezzi da incollare, le frecce bianche indicano i pezzi da montare senza colla. Usare solo colla per polistirolo. Le lettere (A - B - C...) ai lati dei numeri indicano la stampata ove si trova il pezzo da montare. I pezzi sbarrati da una croce non sono da utilizzare.

**DE ACHTUNG - Ein nützlicher Rat!**

VOR DER MONTAGE DIE ZEICHNUNG AUFRMERKSAM STUDIERN. DIE EINZELNEN MONTAGETEILE MIT EINEM MESSER ODER EINER SCHERE VOM SPRITZLING SORFÄHIG ENTFERNEN. EVENTUELLE GRATE WERDEN MIT EINER KLINGE ODER FEINEM SCHMIRGELPAPIER BESÄTTIGT. KEINESFALLS DIE MONTAGETEILE MIT DEN HÄNDEN ENTFERNEN. BEI DER MONTAGE DER TAFELNUMERIERUNG FOLGEN. PFEILE ZEIGEN DIE ZU KLEBENDEN TEILE WÄHREND DIE WEISSEN PFEILE DIE OHNE LEIM ZU MONTIERENDEN TEILE ANZEIGEN. BITTE NUR PLASTIKLEBSTOFF VERWENDEN. DIE BUCHSTABEN (A - B - C...) NEBEN DEN NUMMIERN ZEIGT AUF WELCHEM SPRITZLING DER ZU MONTIERENDE TEIL ZU FINDEN IST. DIE MIT EINEM KREUZ MARKIERTEN TEILE SIND NICHT ZU VERWENDEN.

**FR ATTENTION - Conseils utiles!**

AVANT DE COMMENCER LE MONTAGE, ÉTUDIER ATTENTIVEMENT LE DESSIN. DÉTACHER AVEC BEAUCOUP DE SOIN LES MORCEAUX DES MOULES EN USANT UN MASSICOT OU BIEN UN PAIR DE CISEAUX ET COUPER AVEC UNE PETITE LAME AVEC DE PAPIER DE VITRE FIN ÉBARBAGÉS ÉVENTUELS. JAMAIS DÉTACHER LES MORCEAUX AVEC LE MAINS MONTER LES EN SUIVANT L'ORDRE DE LA NUMÉRATION DES TABLES. ÉLIMINER DE LA MOULE LE NUMÉRO DE LA PIÈCE QUI VIENT D'ÊTRE MONTÉE. EN LE BIFFANT AVEC UNE CROIX. LES FLÈCHES NOIRES INDICENT LES PIÈCES À COLLER, LES FLÈCHES BLANCHES INDICENT LES PIÈCES À MONTER SANS COLLE. EMPLOYER SEULEMENT DE LA COLLE POUR POLYSTYRÈLE. LES LETTRES (A - B - C...) AUX CÔTÉS DES NUMÉROS INDICENT LA MOULE OÙ SE TROUVE LA PIÈCES À MONTER. LES PIÈCES MARQUÉES PAR UNE CROIX NE SONT PAS À UTILISER.

**ES ATENCION - Consejos útiles!**

ESTUDIAR LAS INSTRUCCIONES CUIDADOSAMENTE ANTES DE COMENZAR EL MONTAJE. SEPARAR LAS PIEZAS DE LAS BANDEJAS CON UN CUCHILLO AFILADO O UN PAR DE TIJERAS Y RETIRAR EL EXCESO DE PLÁSTICO O REBADA. NO ARRANCAR LAS PIEZAS. MONTAR LAS PIEZAS EN ORDEN NUMÉRICO. UTILIZAR SOLAMENTE PEGAMENTO PARA PLÁSTICO Y EN POCA CANTIDAD PARA EVITAR QUE SE DANIE EL MODELO. LAS FLECHAS NEGRAS INDICAN LAS PIEZAS QUE SE DEBEN PEGAR JUNTAS. LAS FLECHAS BLANCAS INDICAN LAS PIEZAS QUE DEBEN ENSAMBLARSE SIN USAR PEGAMENTO. LAS LETRAS (A - B - C...) INDICAN EN QUE BANDEJA SE ENCUENTRAN LAS PIEZAS. PINTAR LAS PIEZAS PEQUEÑAS ANTES DE SEPARARLAS DE LA BANDEJA. RETIRAR LA PINTURA DE LOS LUGARES POR DONDE SE DEBAN PEGAR LAS PIEZAS.

**RU ПРЕДУПРЕЖДЕНИЕ - советы!**

ПЕРЕД ТЕМ, КАК ПРИСТУПИТЬ К СБОРКЕ, ВНИМАТЕЛЬНО ИЗУЧИТЬ ЧЕРТЁЖ. ОЧЕНЬ ОСТОРОЖНО ОТСОЕДИНИТЬ РАСПЕЧАТАННЫЕ ЭЛЕМЕНТЫ. ИСПОЛЬЗОВАТЬ ДЛЯ ЭТОГО КАНИЦЕВЫЙ НОЖ ИЛИ ПАРУ НОЖИЦ, СНИТЬ НЕРОВНОСТИ С ПОМОЩЬЮ ТОНКОГО ЛЕЗВИЯ ИЛИ С ПОМОЩЬЮ АБРАЗИВНОЙ БУМАГИ. НЕ ОТСОЕДИНЯТЬ ЭЛЕМЕНТЫ РУКАМИ. ВЫПОЛНИТЬ СБОРКУ СОГЛАСНО ПОРЯДКУ НУМЕРАЦИИ ТАБЕЛИ, УДАЛИТЬ ИЗ СПИСКА ТОЛЬКО ЧТО СОБРАННУЮ ДЕТАЛЬ, ПЕРЕЧЕРКНУТЫЕ Б.Е. ЧЕРНЫЕ СТРЕЛКИ УКАЗЫВАЮТ ДЕТАЛИ ДЛЯ СБОРКИ, БЕЛЫЕ СТРЕЛКИ УКАЗЫВАЮТ ДЕТАЛИ, КОТОРЫЕ СБИРАЮТСЯ БЕЗ КЛЕЯ. ИСПОЛЬЗОВАТЬ ТОЛЬКО КЛЕЙ ДЛЯ ПОЛИСТАЦИ. БУКВЫ (А - В - С...) НА ПРОНУМЕРОВАННЫХ СТОРОНАХ УКАЗЫВАЮТ ЛИСТ, ГДЕ НАХОДИТСЯ ДЕТАЛЬ. ПЕРЕЧЕРКНУТЫЕ ДЕТАЛИ НЕ ИСПОЛЬЗУЮТСЯ.

**A**

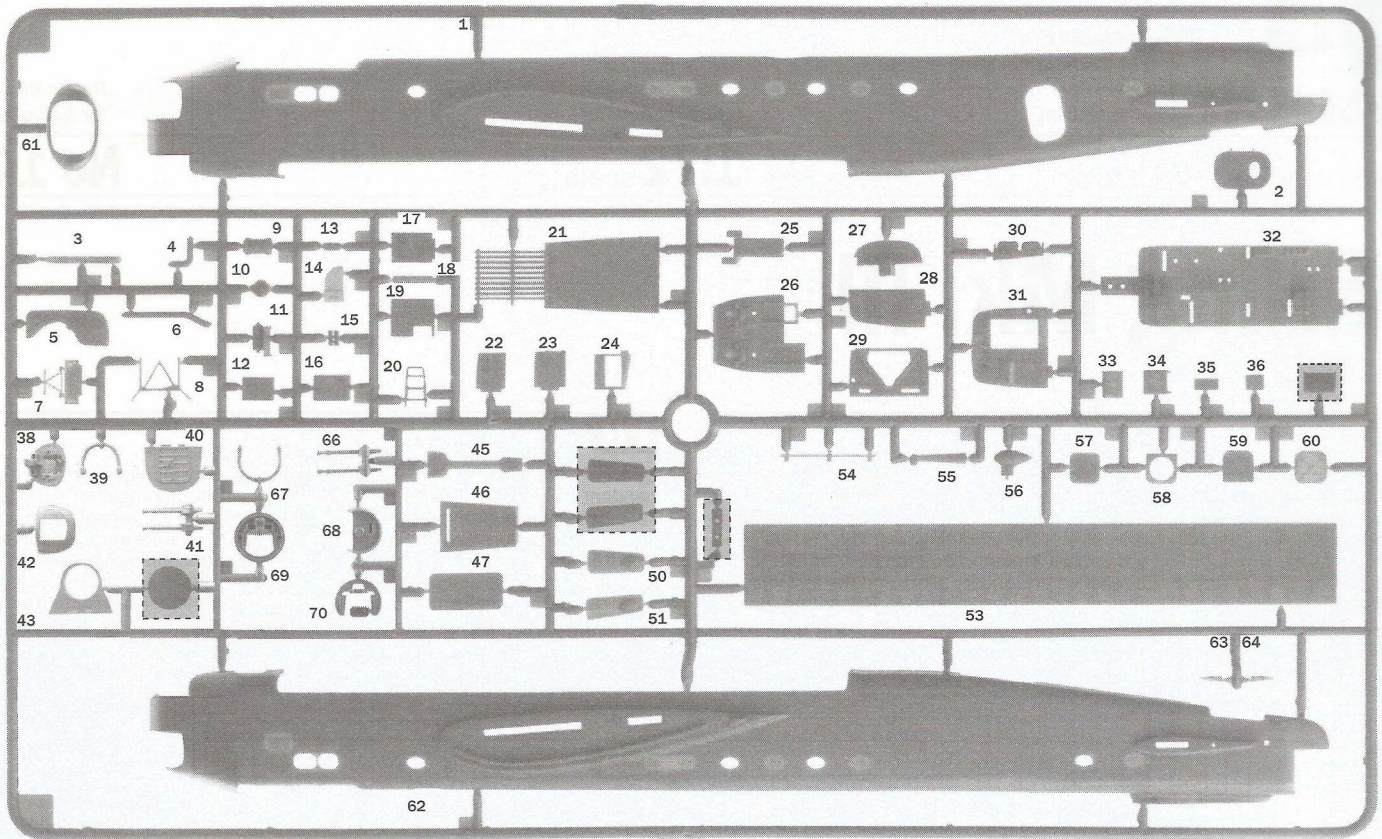

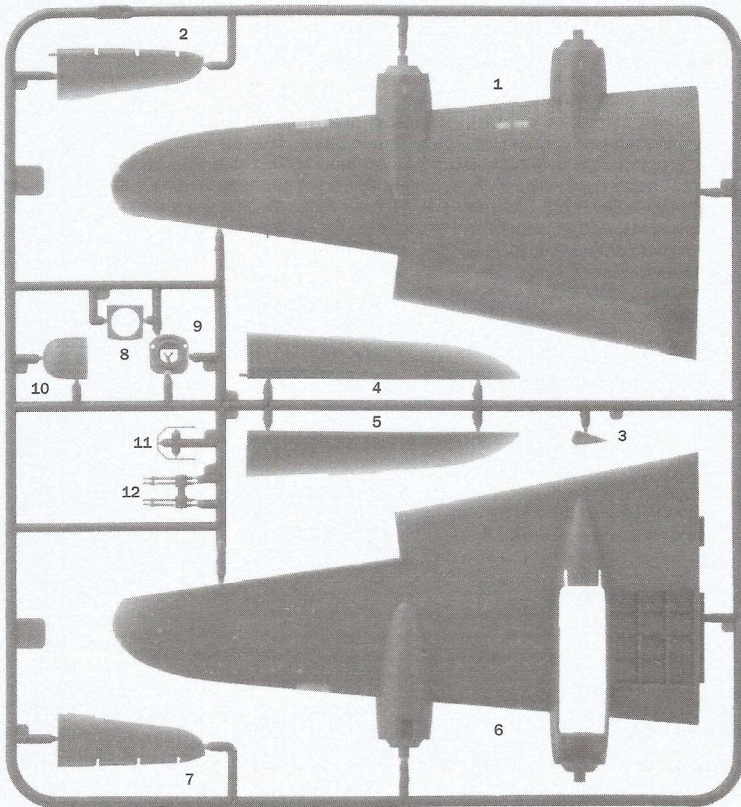

**C**

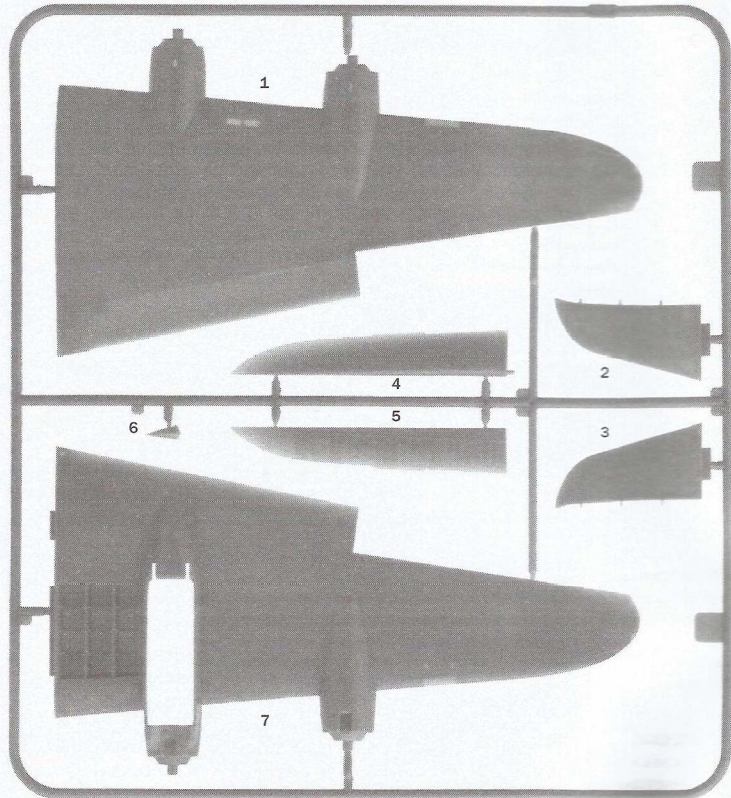

**B**





 Parti da non utilizzare  
 Parts not for use  
 Pièces à ne pas utiliser  
 Teile werden nicht verwenden

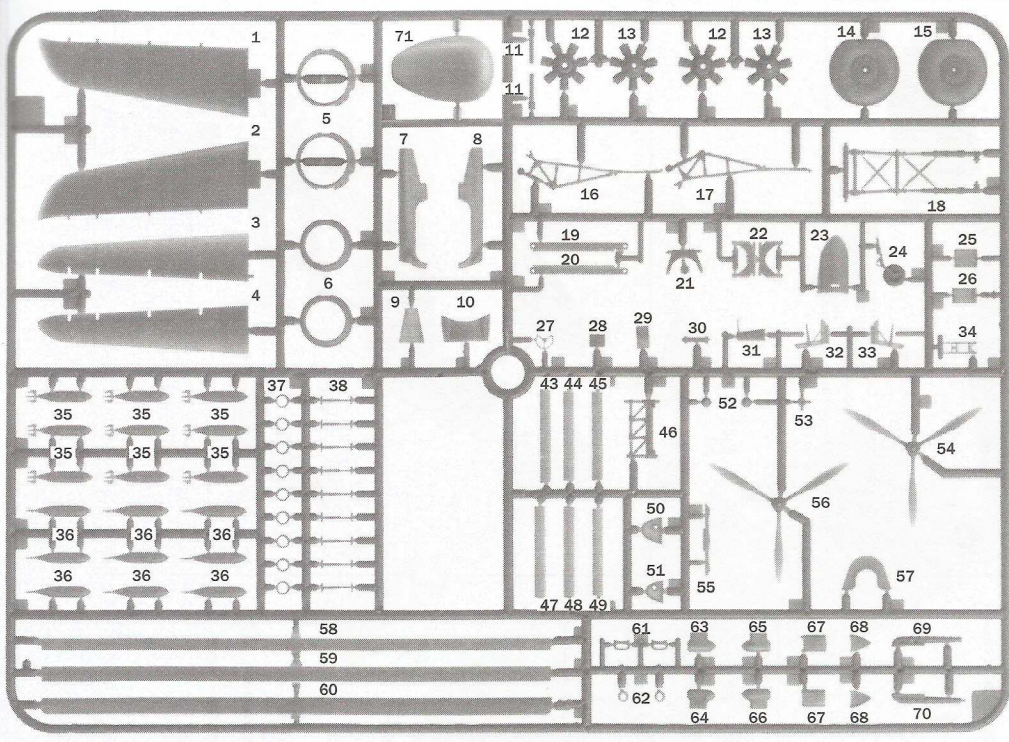

 Aprire i fori  
 Drill holes  
 Ouvrir les trous  
 Die Locher Ausböhren

 Separare  
 Cut  
 Retirer  
 Entfernen

D

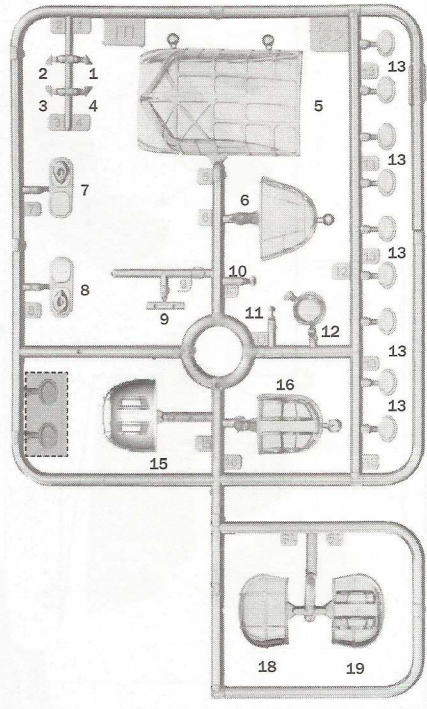

E



D

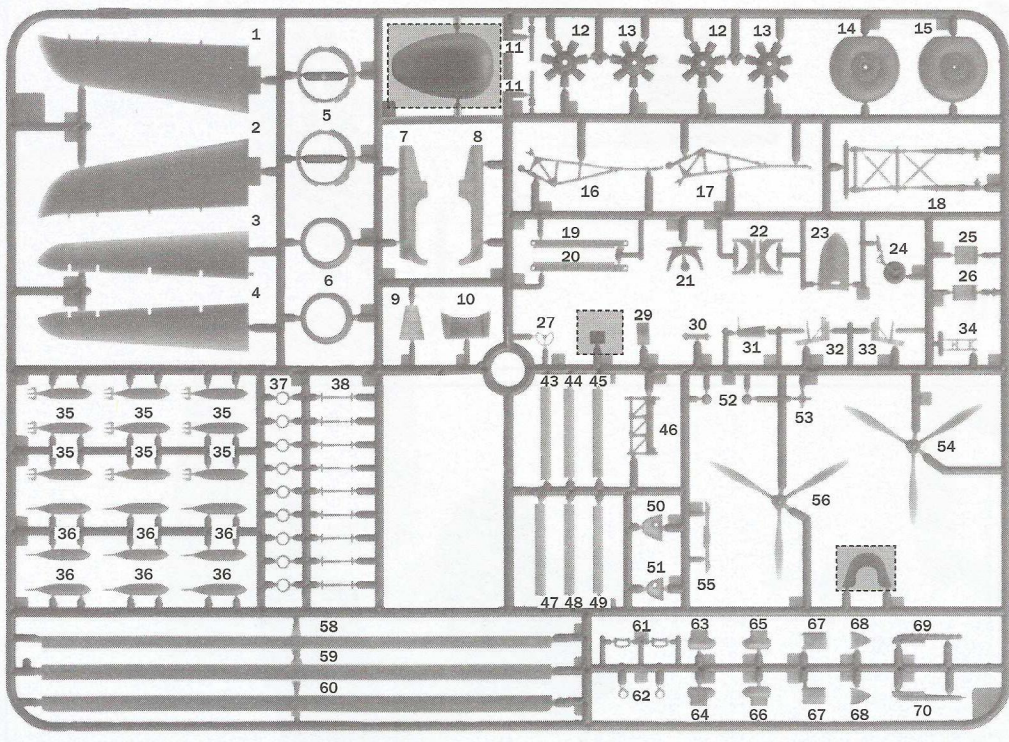

PE

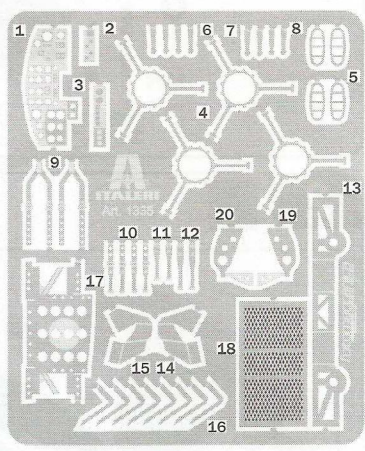

### SUGGESTED COLORS

|  |   |   |  |   |
|--|---|---|--|---|
| <p><b>A</b></p> <p><b>FLAT BLACK</b><br/>F.S. 37038<br/>Italeri AcrylicPaint - 4768AP</p>            | <p><b>B</b></p> <p><b>GLOSS WHITE</b><br/>F.S. 17875<br/>Italeri AcrylicPaint - 4696AP</p>    | <p><b>C</b></p> <p><b>FLAT LEATHER</b><br/>F.S. 30100<br/>Italeri AcrylicPaint - 4674AP</p>     | <p><b>D</b></p> <p><b>MET. GLOSS SILVER</b><br/>F.S. 17178<br/>Italeri AcrylicPaint - 4678AP</p>   | <p><b>E</b></p> <p><b>FLAT DARK TAN</b><br/>F.S. 30219<br/>Italeri AcrylicPaint - 4709AP</p>        |
| <p><b>F</b></p> <p><b>FLAT MEDIUM GRAY</b><br/>F.S. 36270<br/>Italeri AcrylicPaint - 4746AP</p>      | <p><b>G</b></p> <p><b>FLAT GUN METAL</b><br/>F.S. 37200<br/>Italeri AcrylicPaint - 4681AP</p> | <p><b>H</b></p> <p><b>GLOSS RED</b><br/>F.S. 11302<br/>Italeri AcrylicPaint - 4605AP</p>        | <p><b>J</b></p> <p><b>FLAT INTERIOR GREEN</b><br/>F.S. 34151<br/>Italeri AcrylicPaint - 4301AP</p> | <p><b>K</b></p> <p><b>FLAT DARK GREEN</b><br/>F.S. 34079<br/>Italeri AcrylicPaint - 4726AP</p>      |
| <p><b>I</b></p> <p><b>METAL FLAT ALLUMINIUM</b><br/>F.S. 37118<br/>Italeri AcrylicPaint - 4677AP</p> | <p><b>L</b></p> <p><b>FLAT RUBBER</b><br/>F.S. 26081<br/>Italeri AcrylicPaint - 4861AP</p>    | <p><b>M</b></p> <p><b>METAL FLAT STEEL</b><br/>F.S. 37178<br/>Italeri AcrylicPaint - 4679AP</p> | <p><b>N</b></p> <p><b>METAL GLOSS BRASS</b><br/>Italeri AcrylicPaint - 4672AP</p>                  | <p><b>O</b></p> <p><b>FLAT INSIGNIA YELLOW</b><br/>F.S. 33538<br/>Italeri AcrylicPaint - 4721AP</p> |

## CHOOSE VERSION BEFORE ASSEMBLY

1

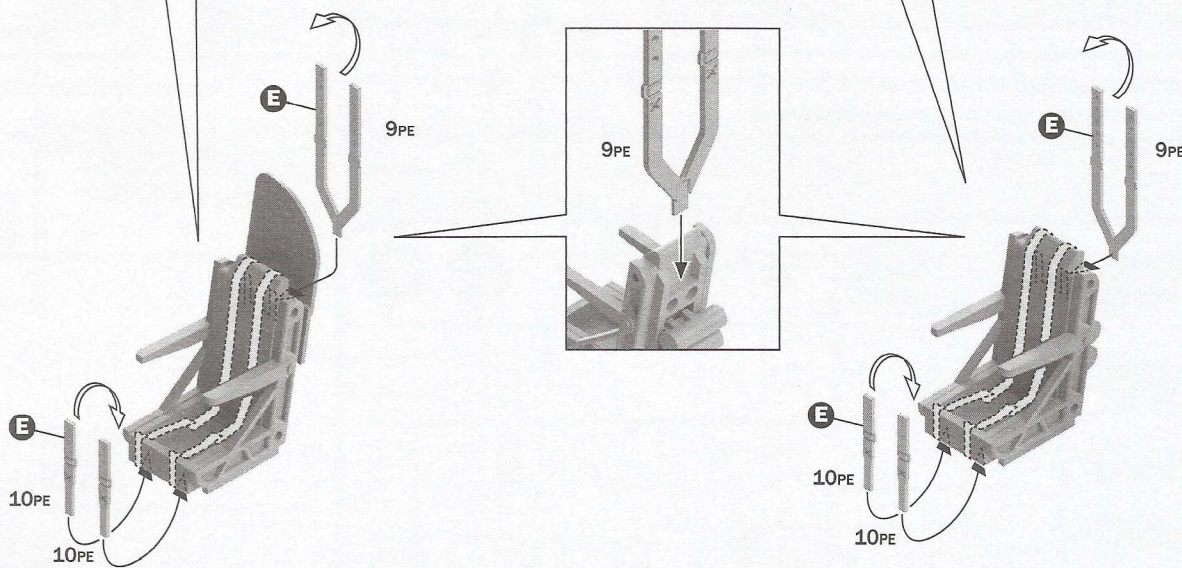
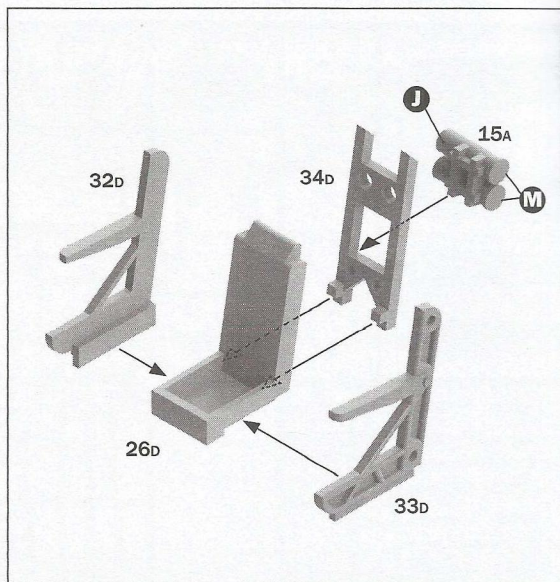
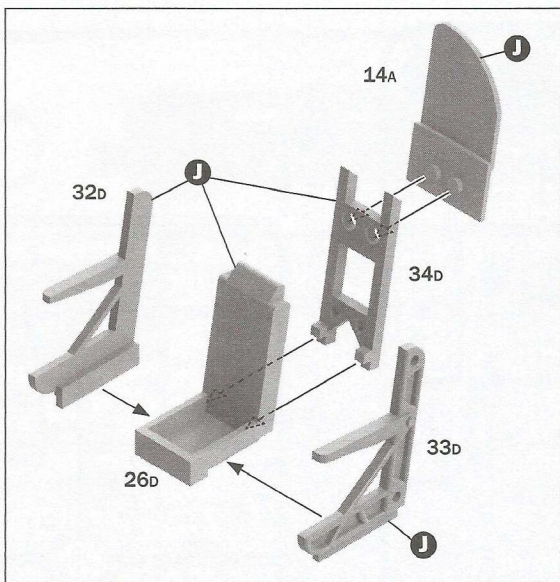

2

A

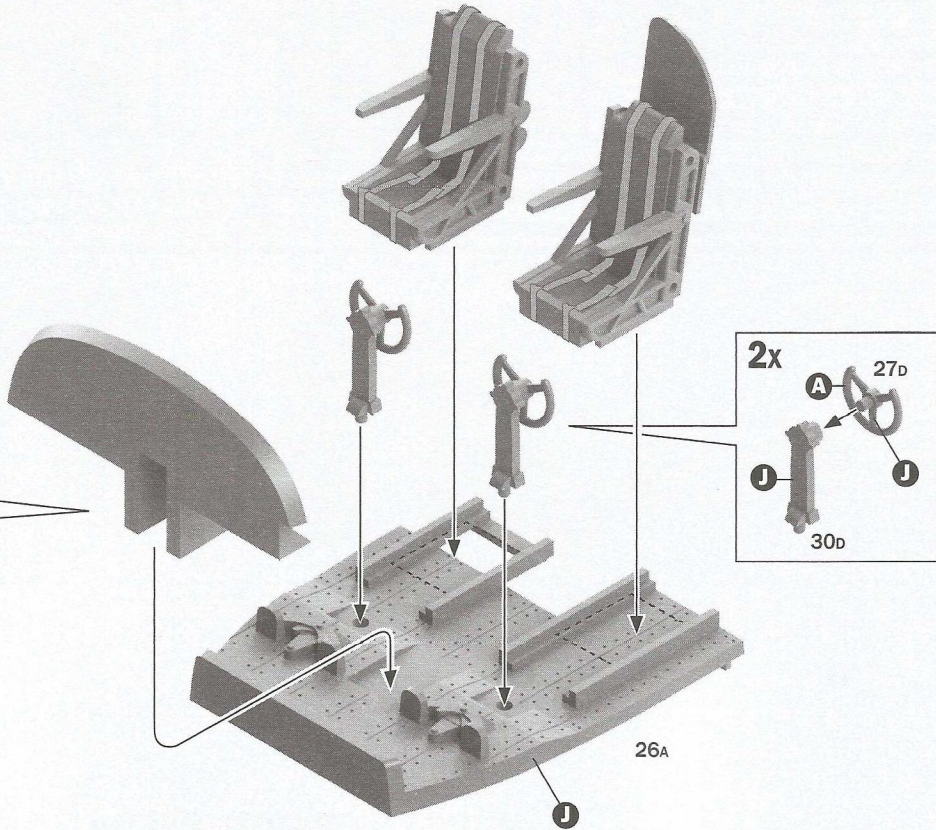
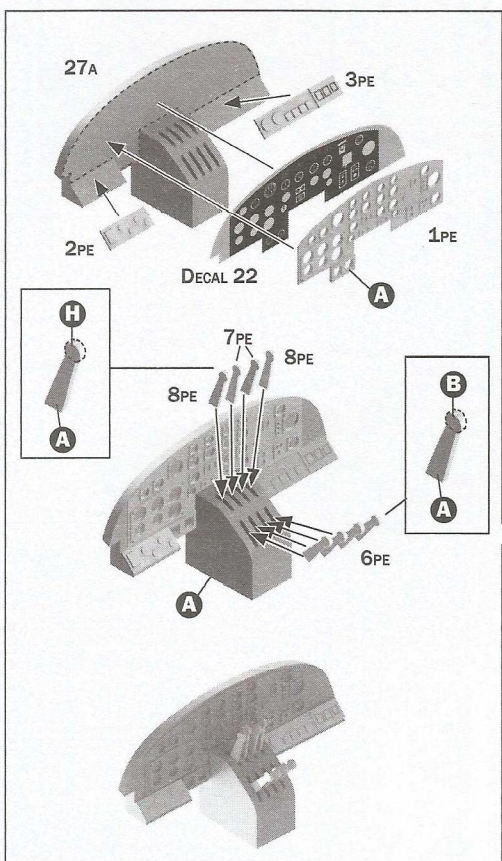

3

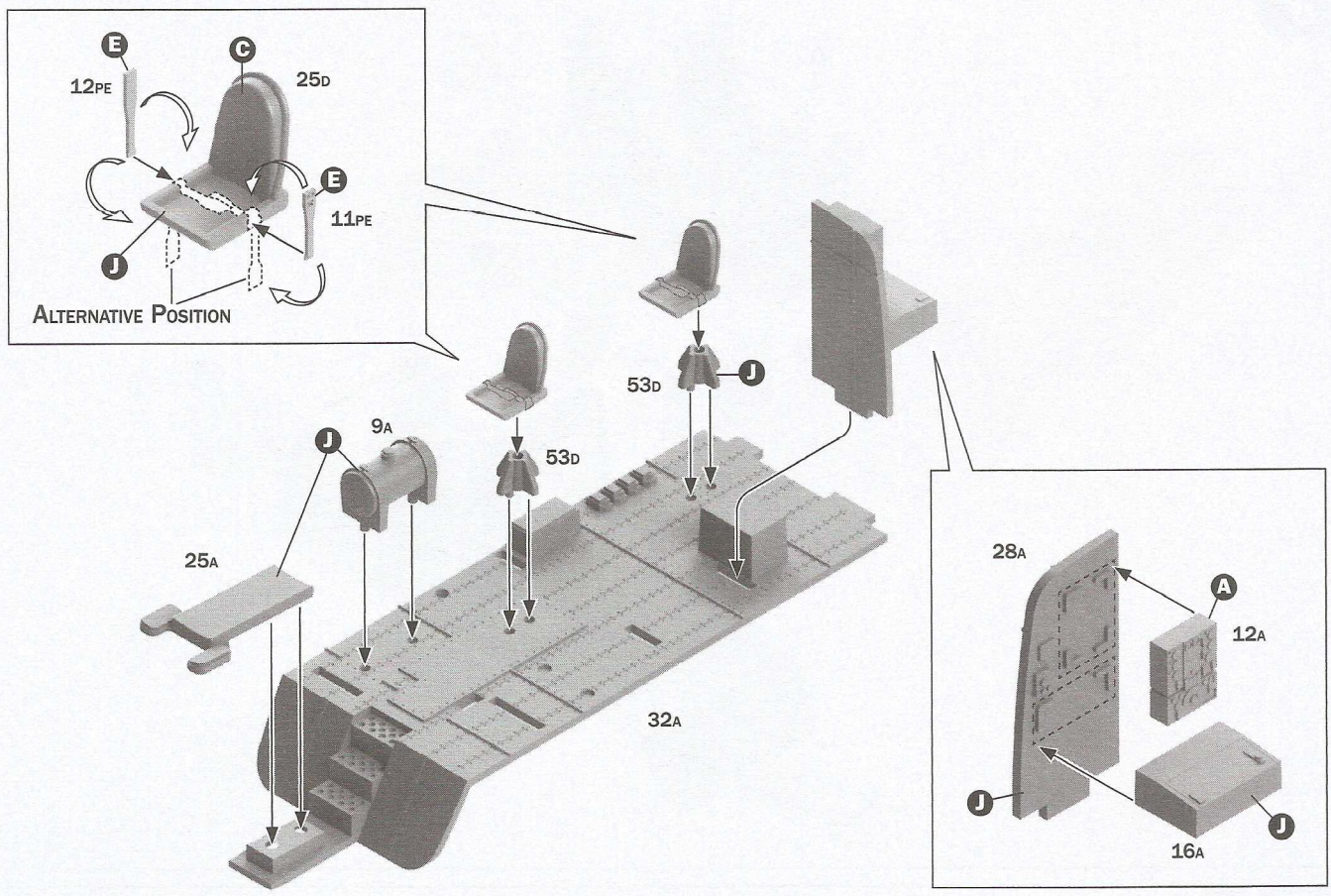

4

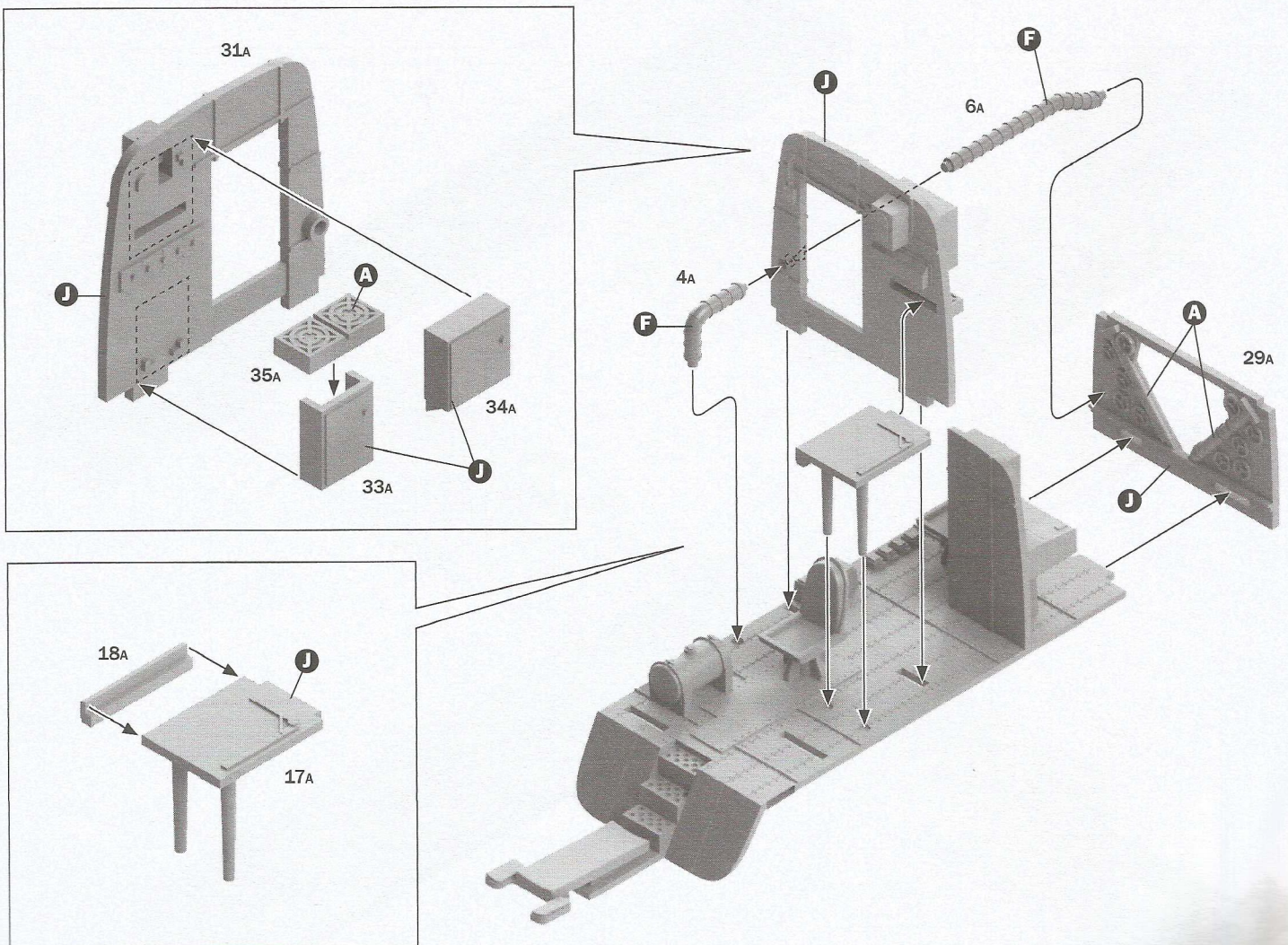

5

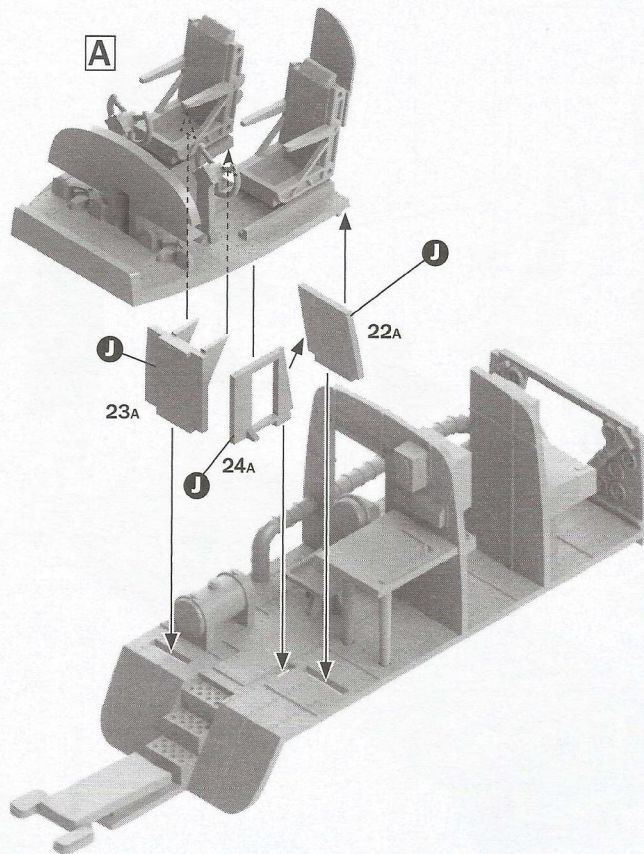

6

B

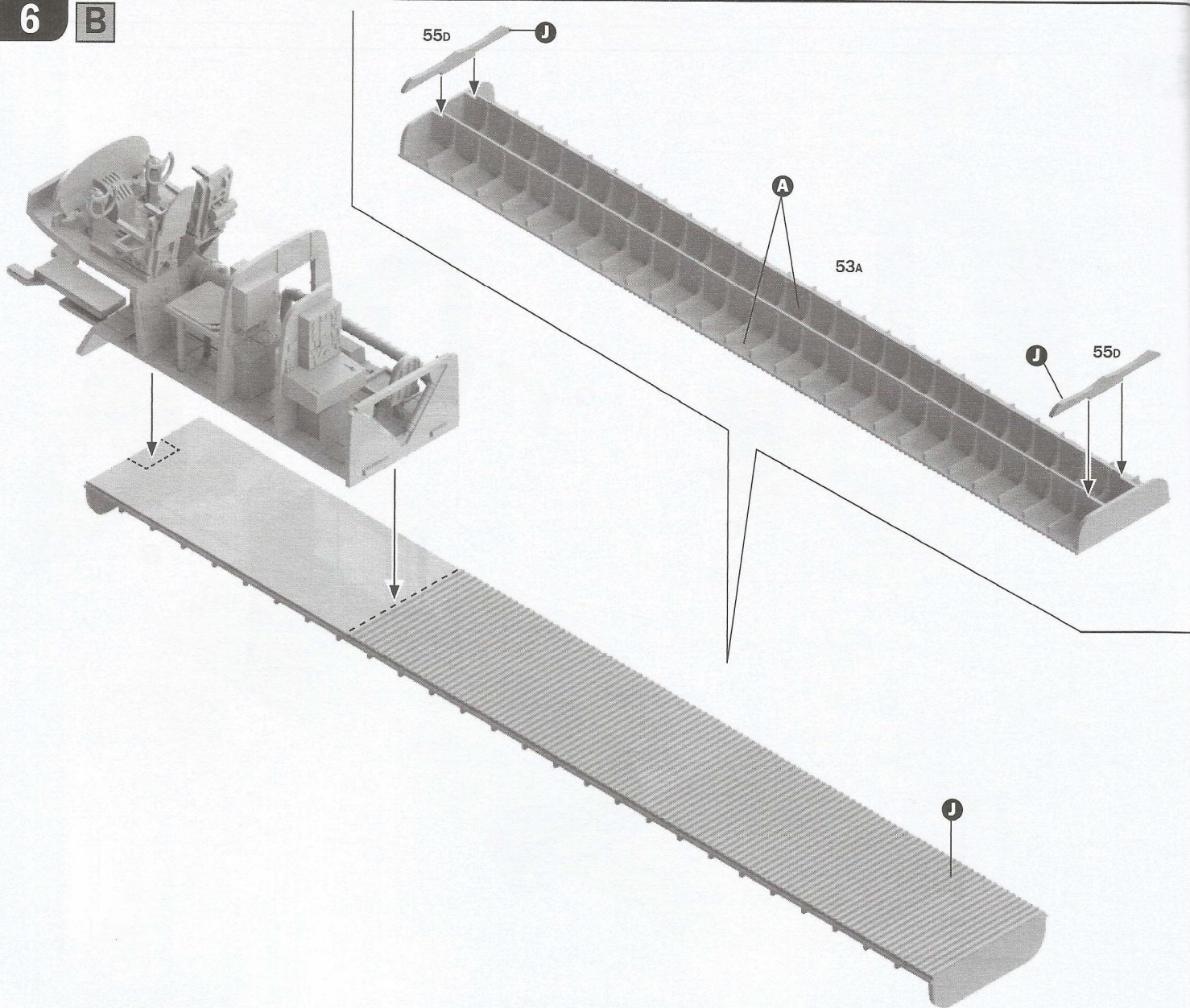

7

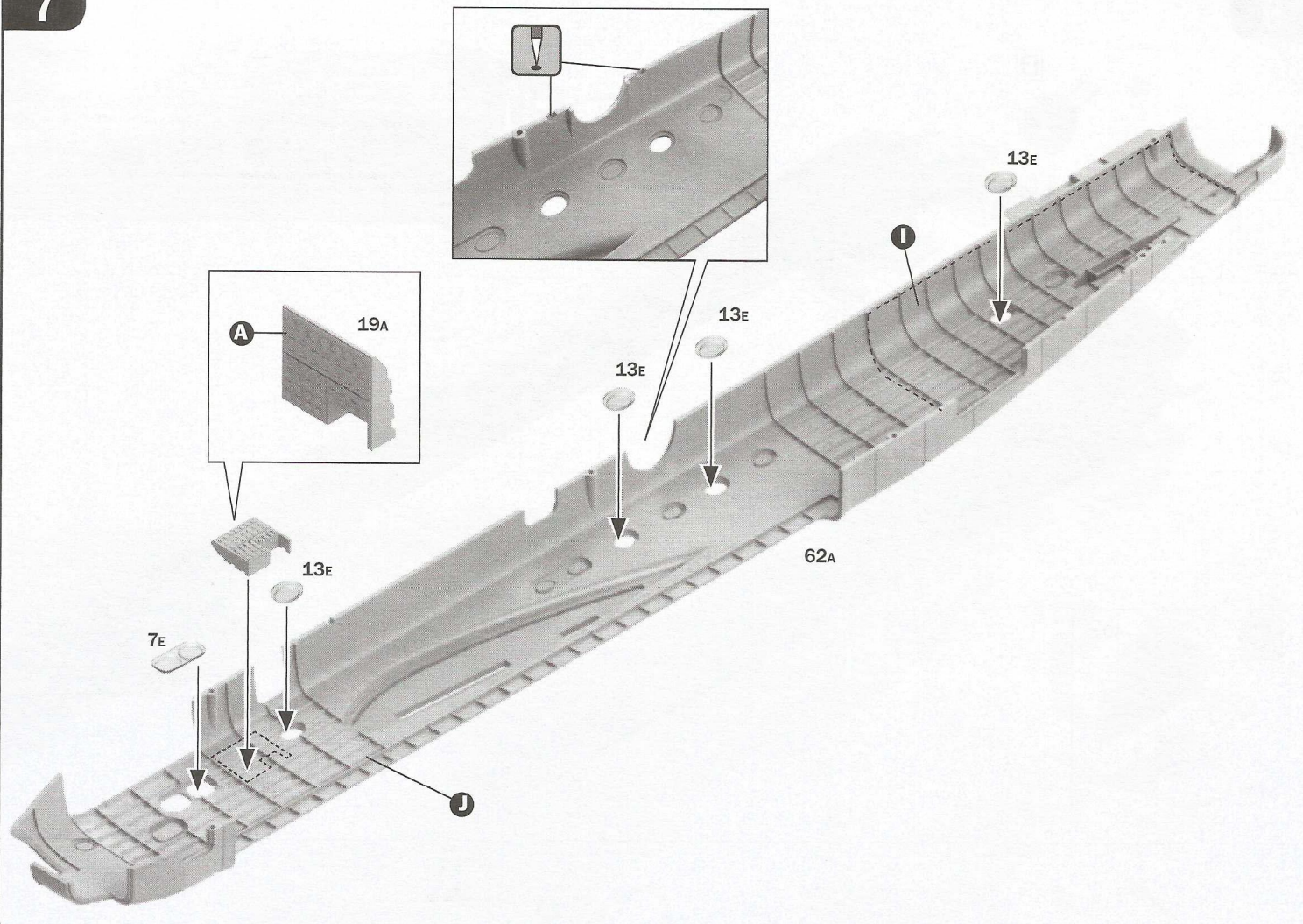

8

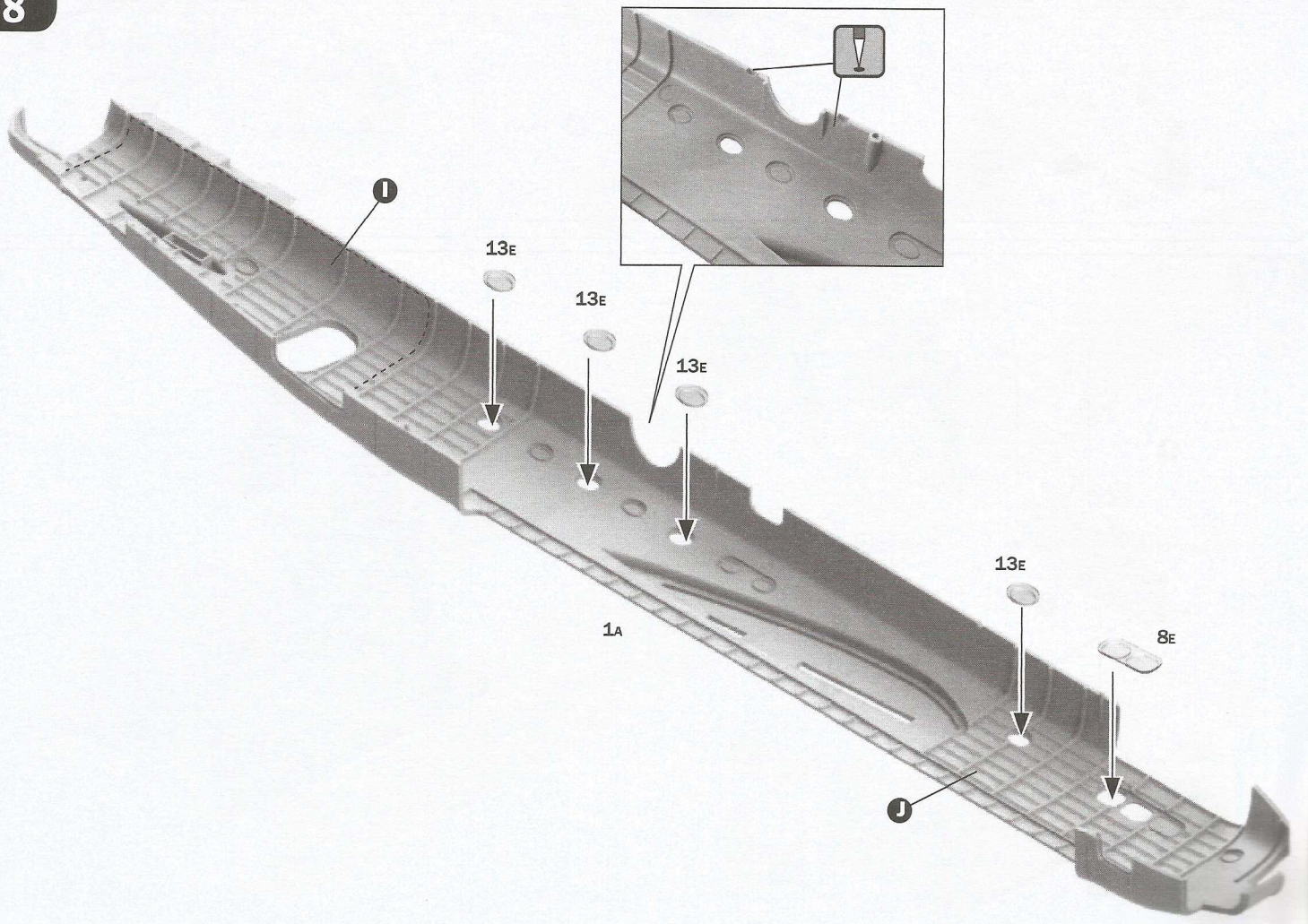

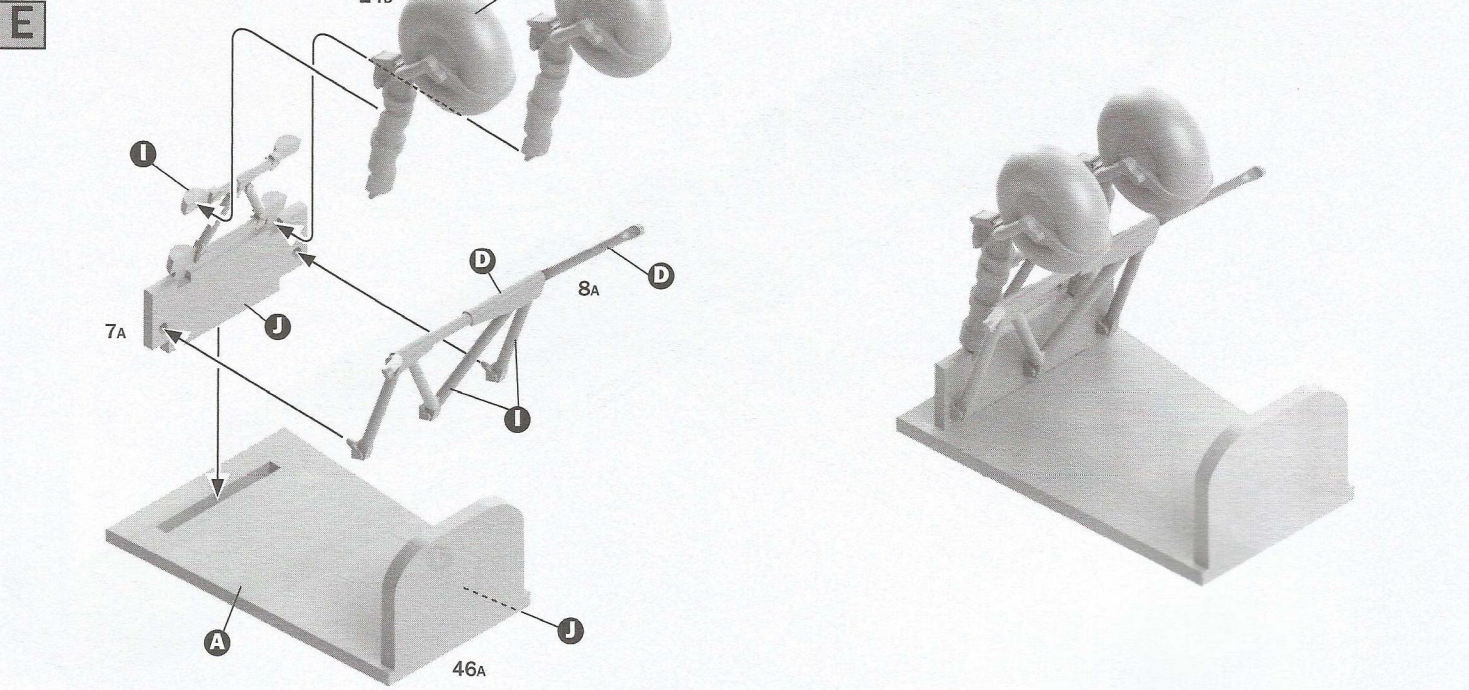
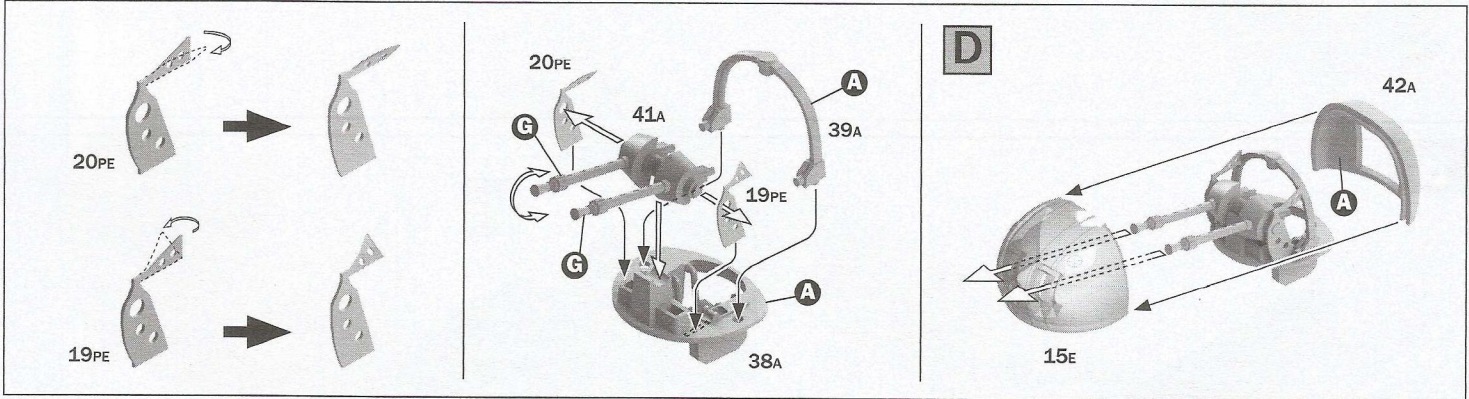
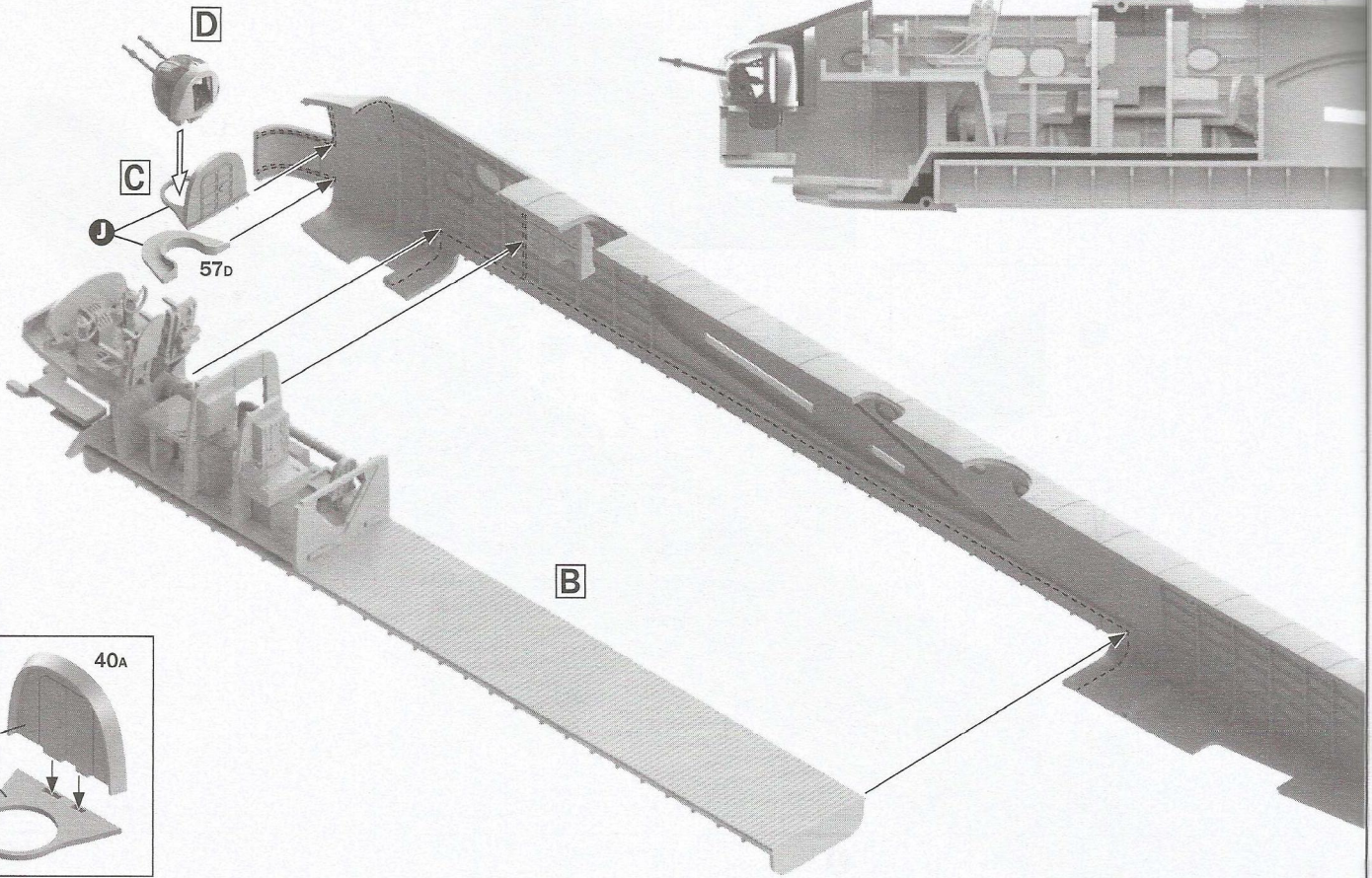



BEND

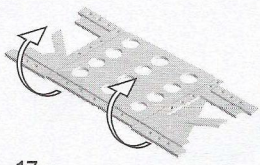

17PE

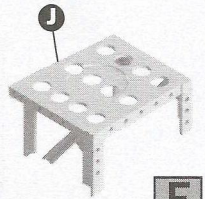
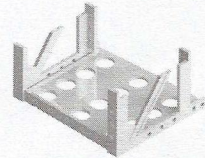
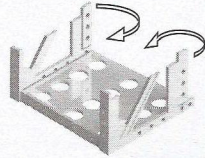
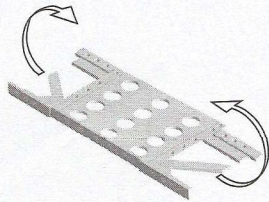

F

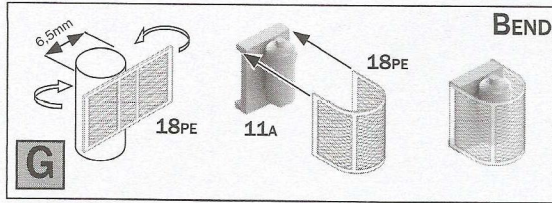

BEND

G

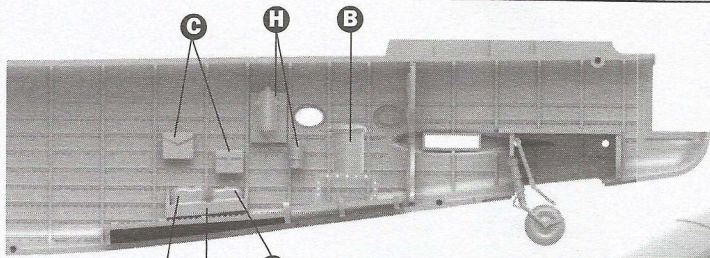

M J M

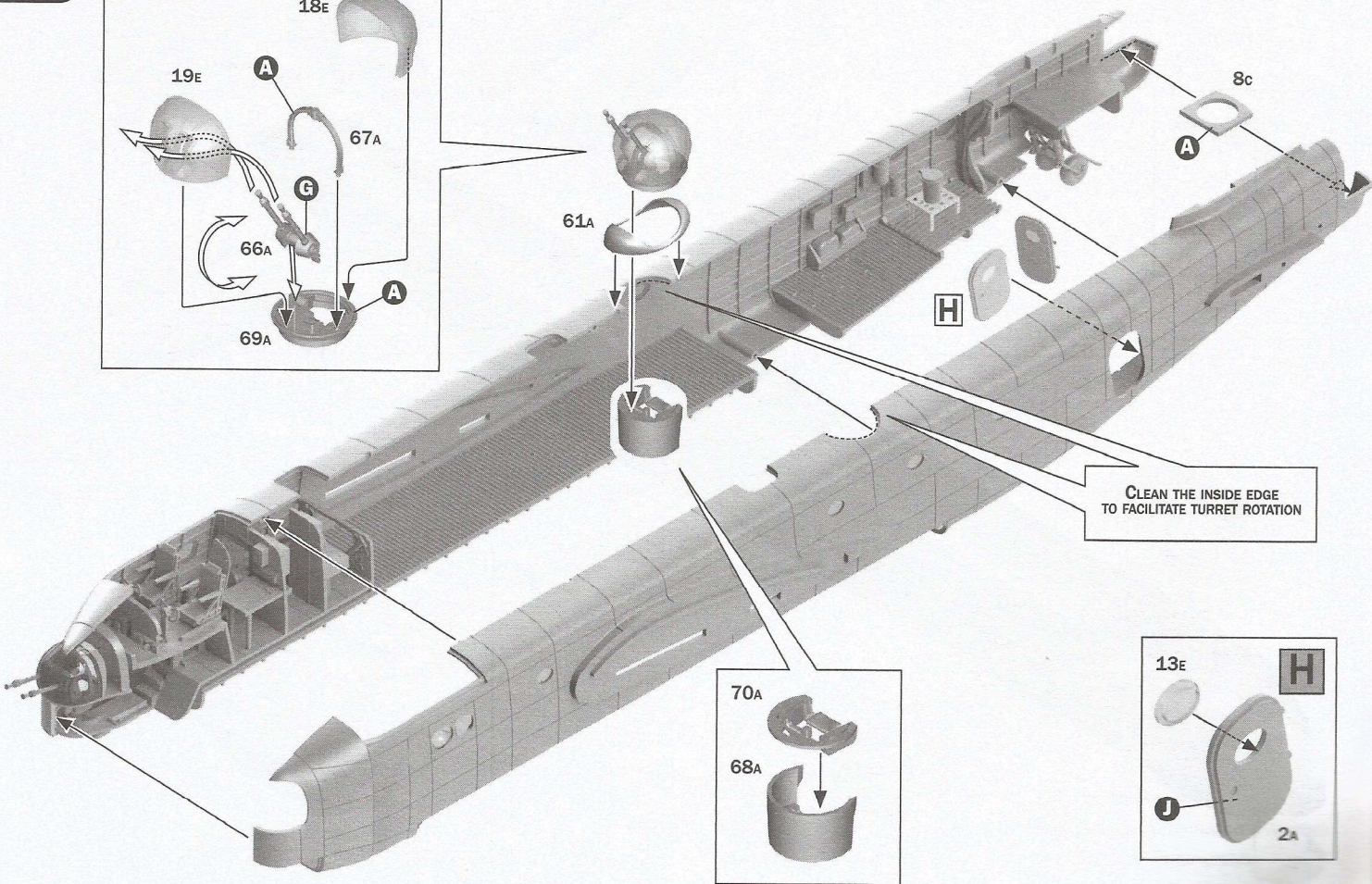
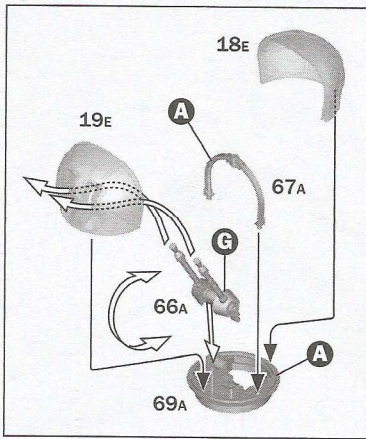
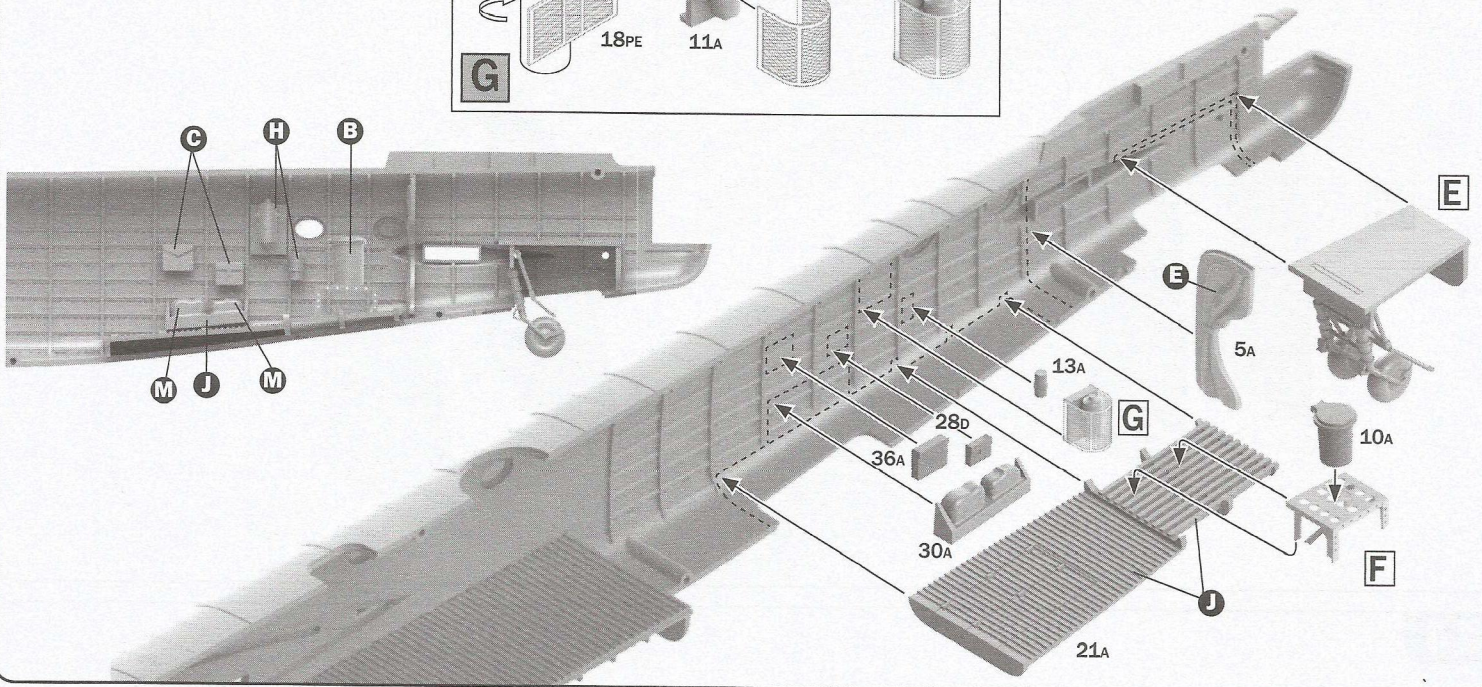

CLEAN THE INSIDE EDGE TO FACILITATE TURRET ROTATION

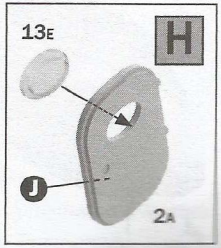
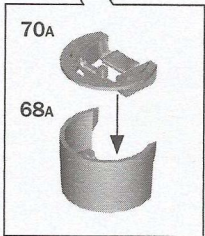

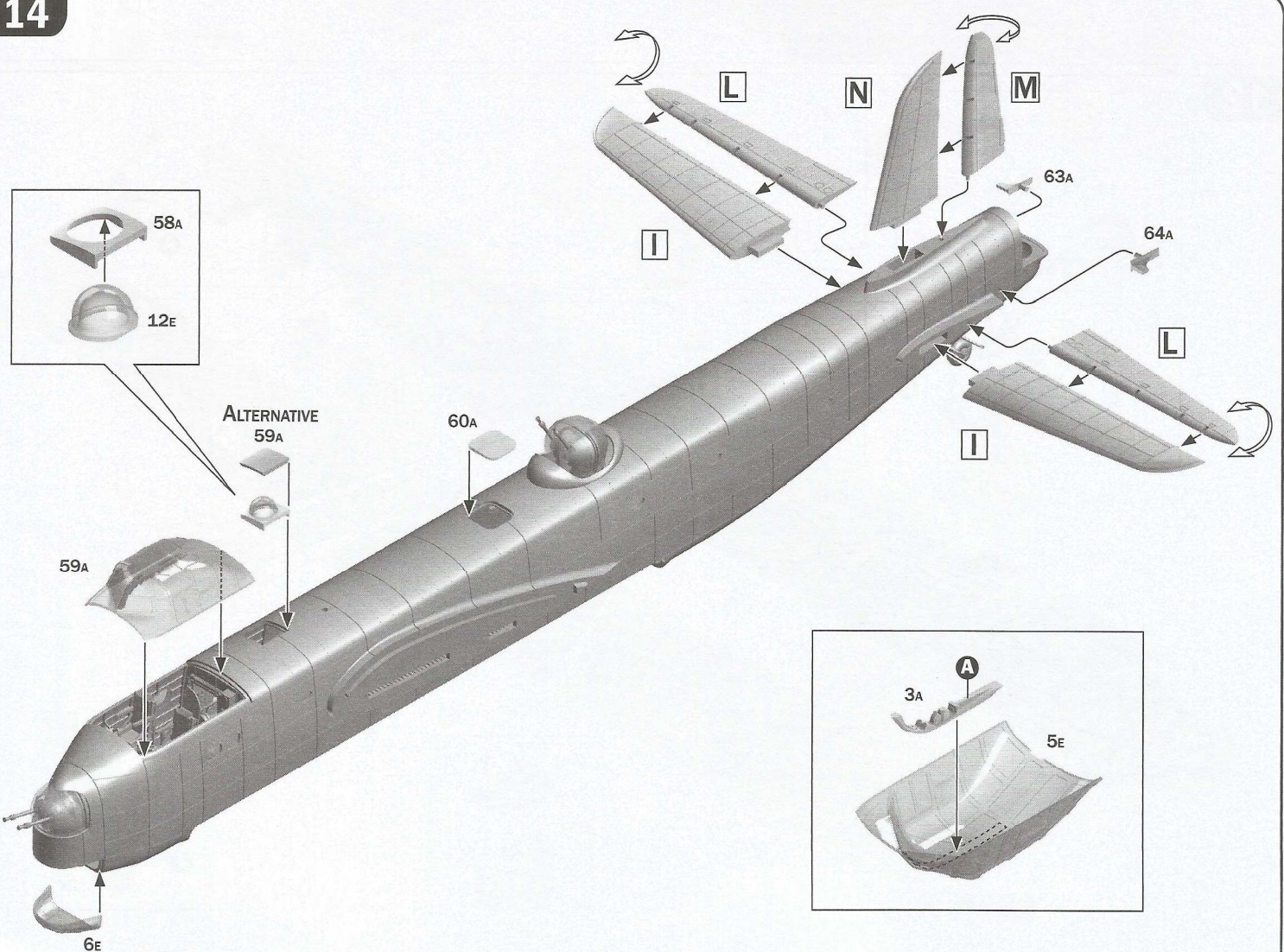
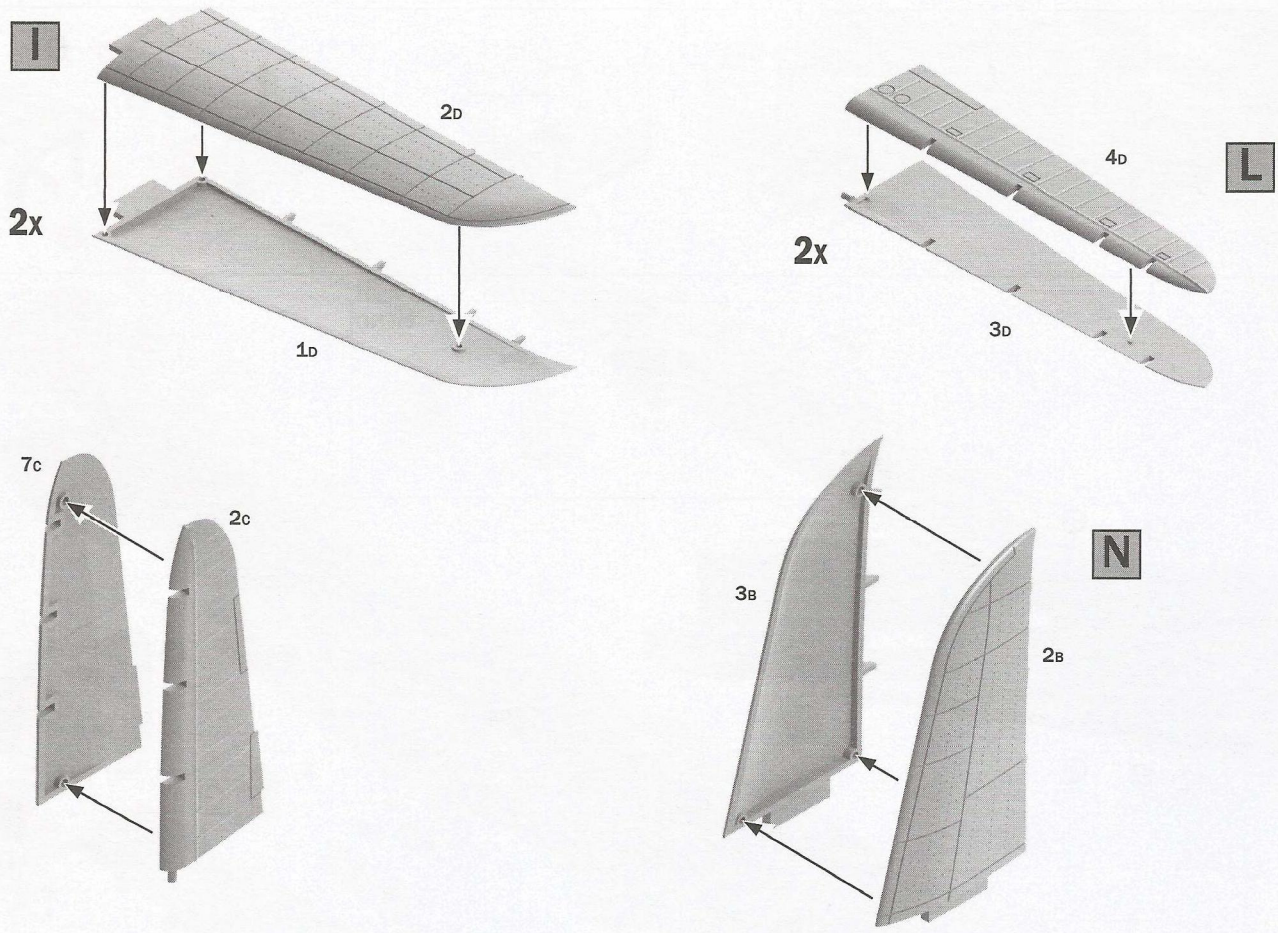

ALTERNATIVE  
CLOSED BOMBS BAY VERSION

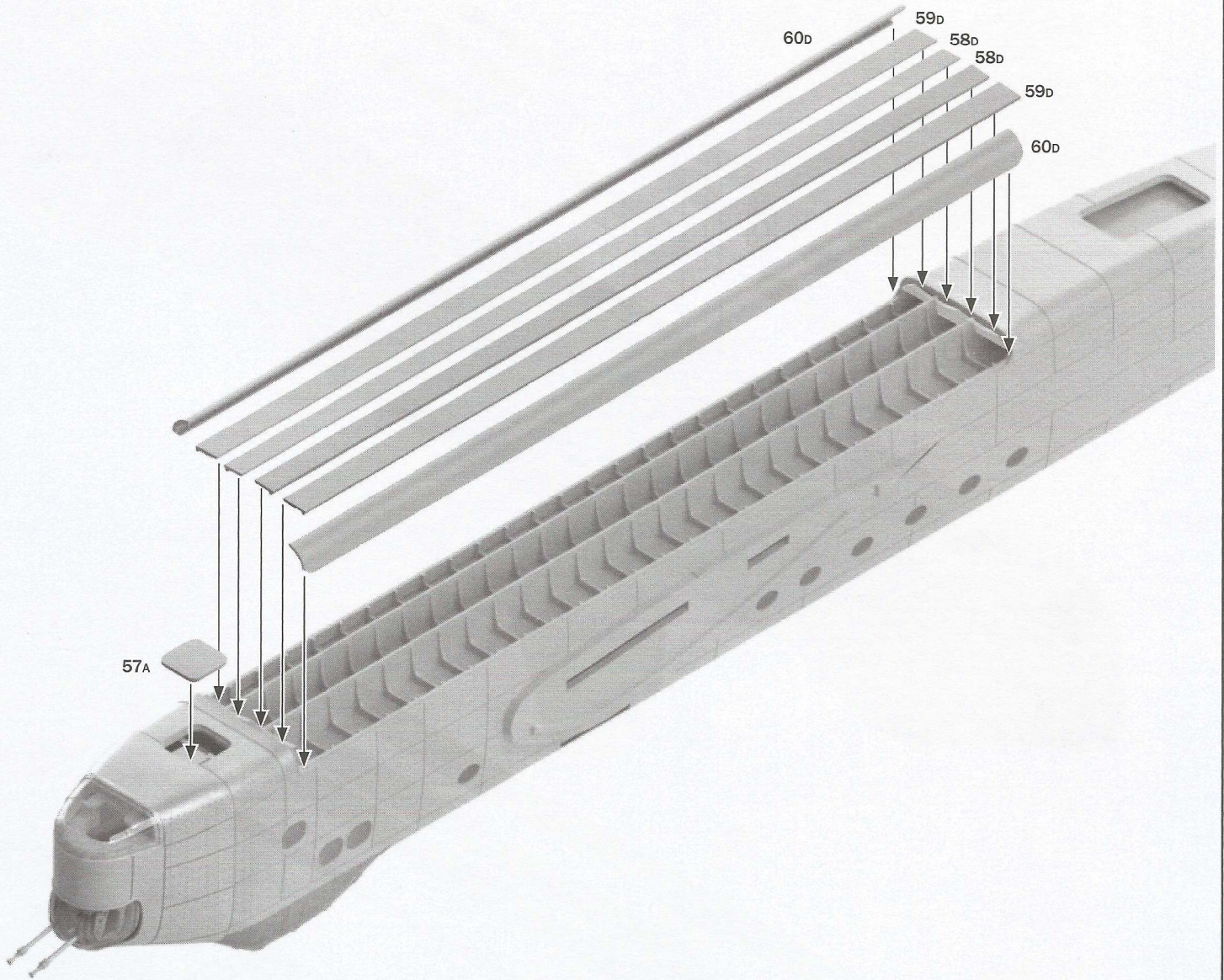

 18x

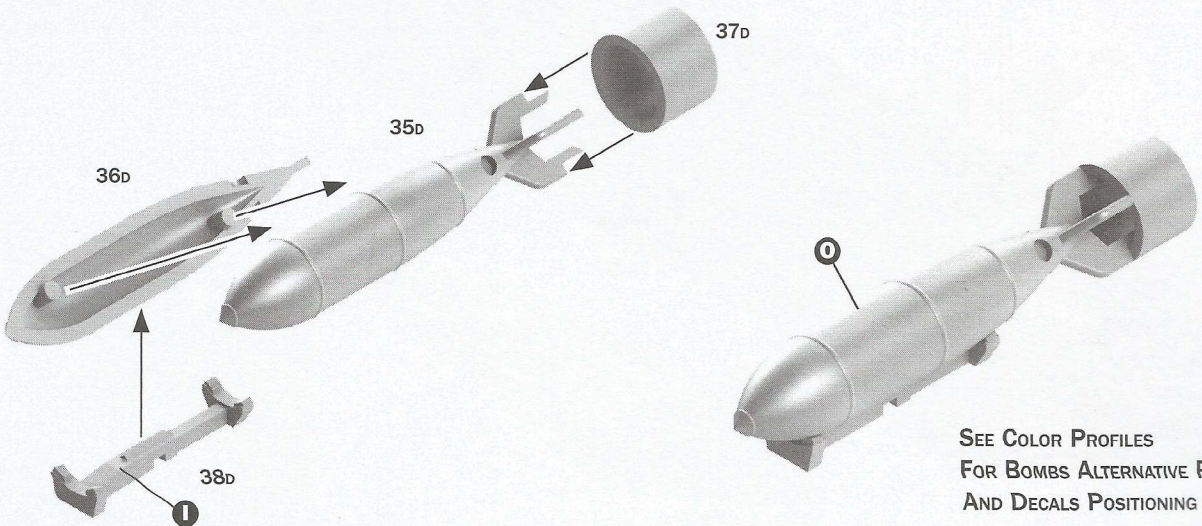

ALTERNATIVE  
OPEN BOMBS BAY VERSION

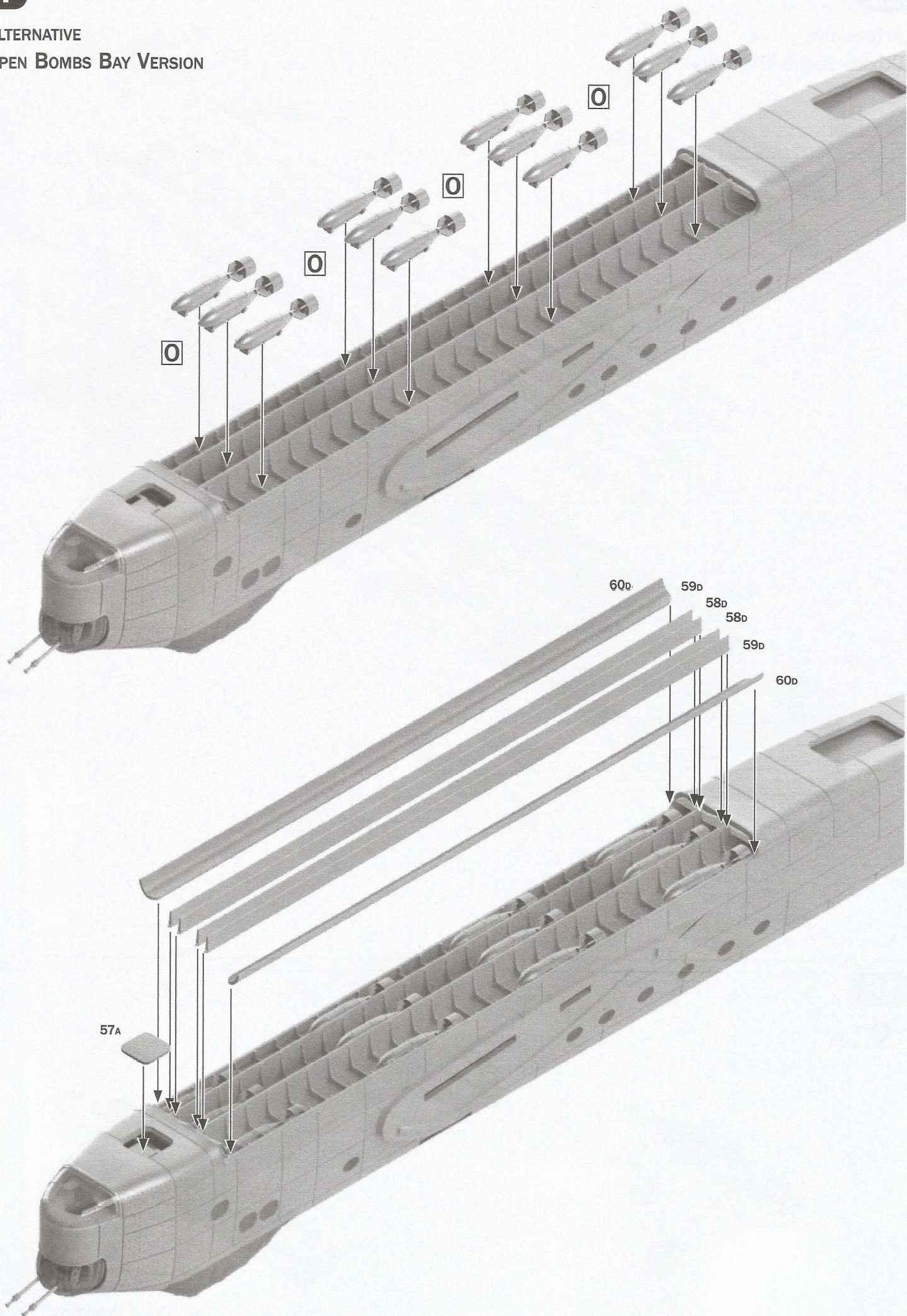

ONLY VERSION E  
37A

ALTERNATIVE - CLOSED POSITION

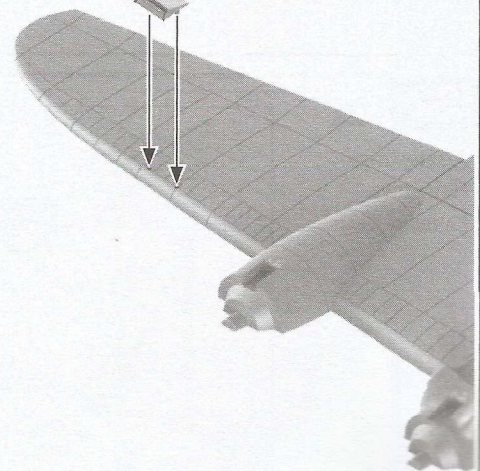
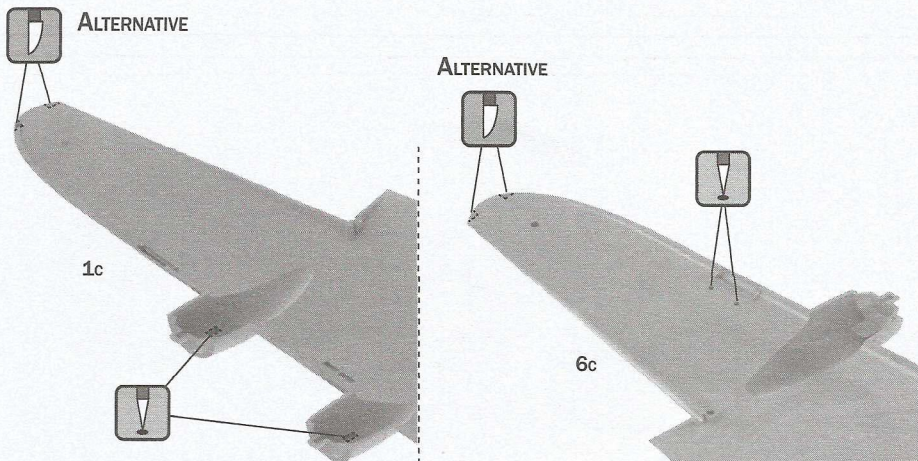
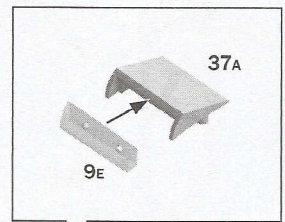
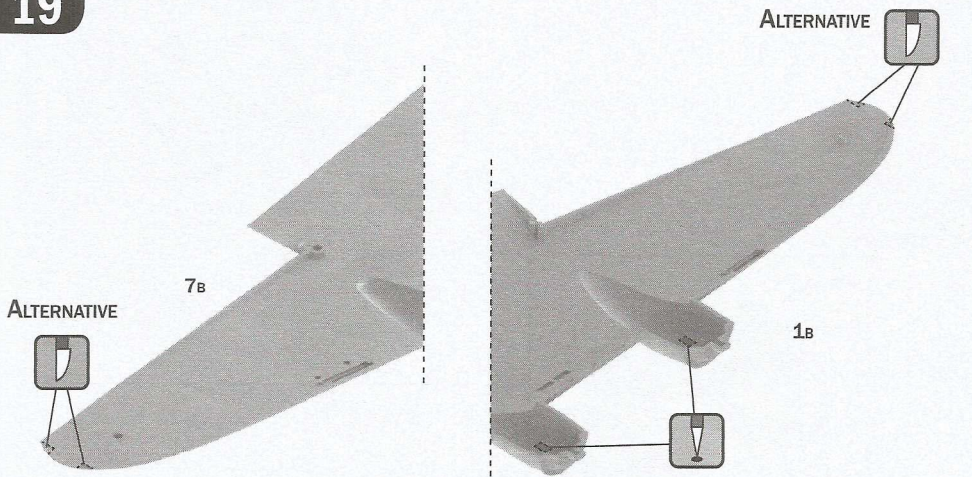
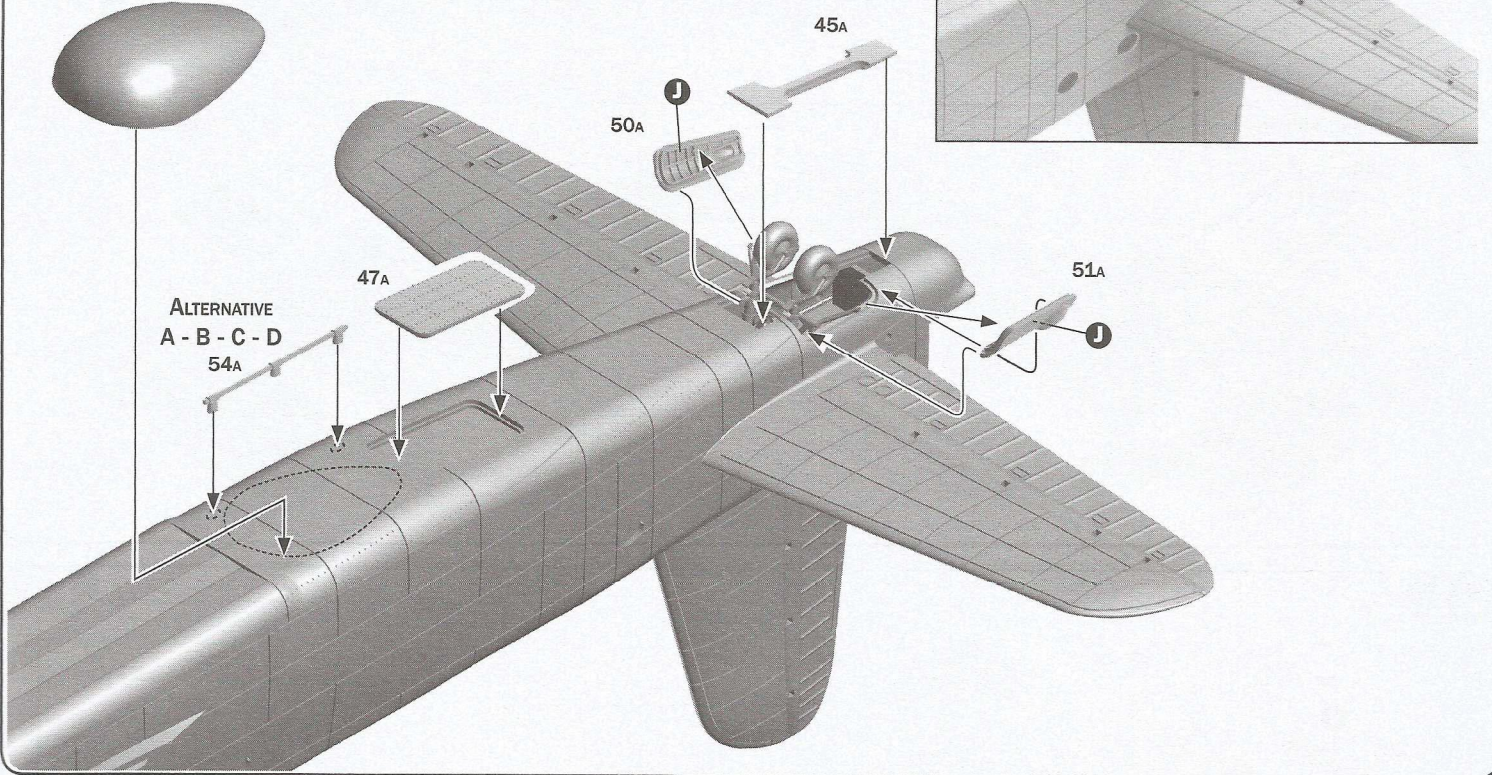

20

0

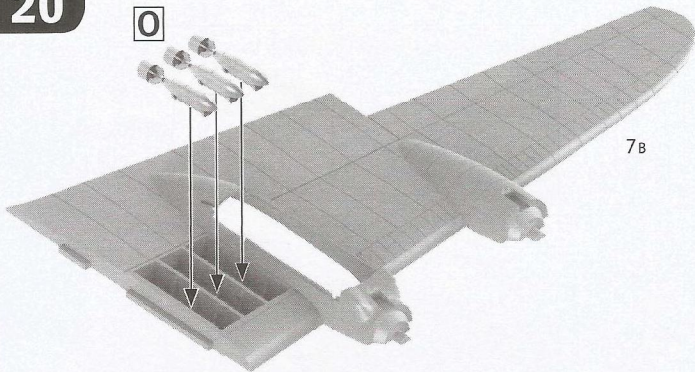

0

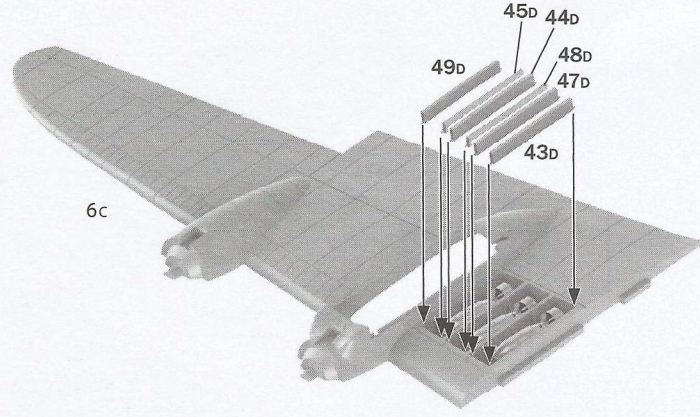
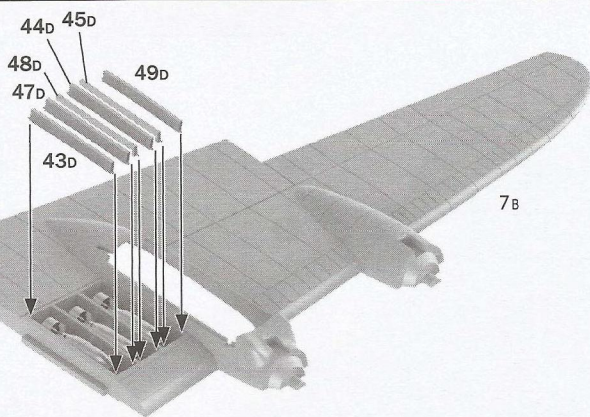
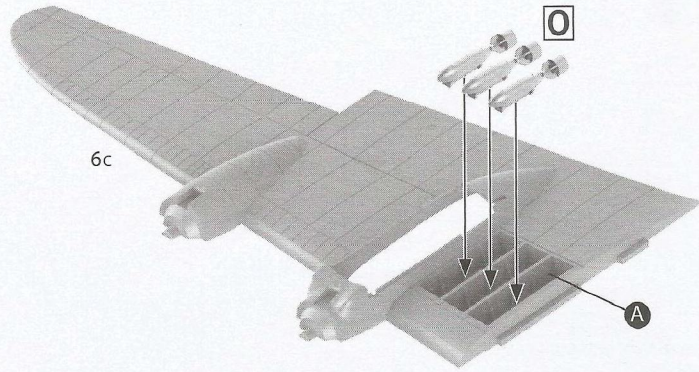

21 2x

ALTERNATIVE EXTENDED LANDING GEAR

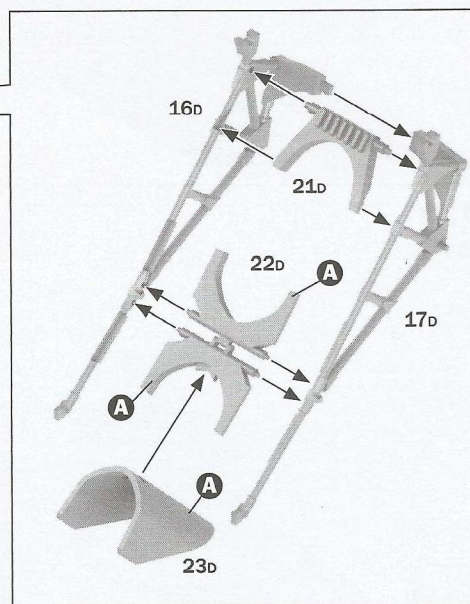
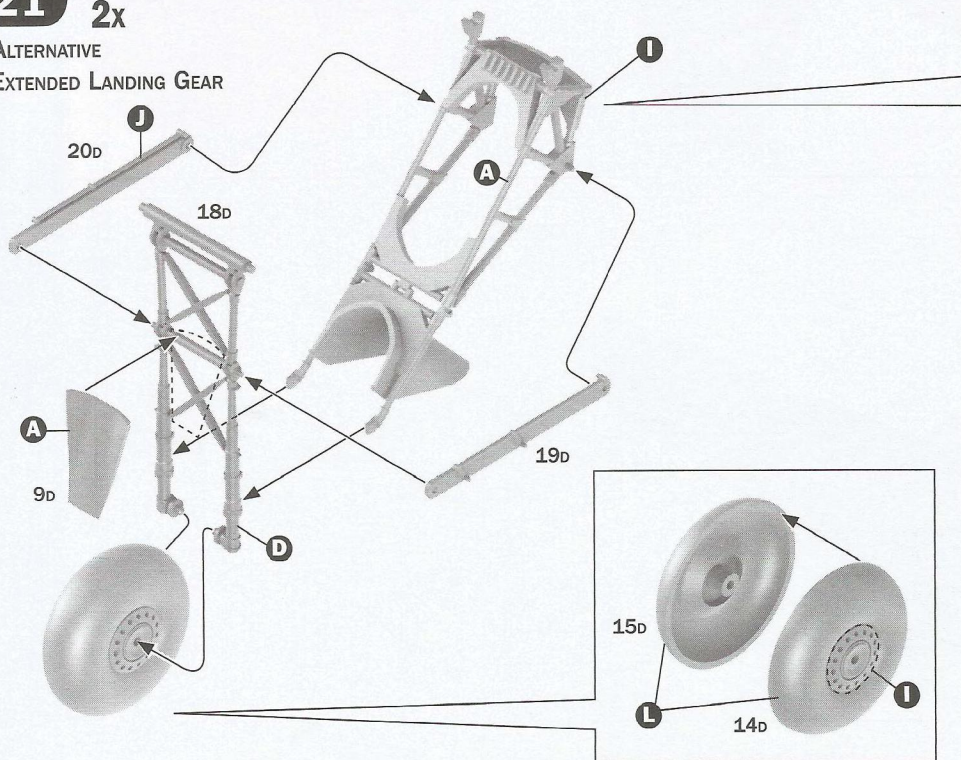

22 2x

ALTERNATIVE RETRACTED LANDING GEAR

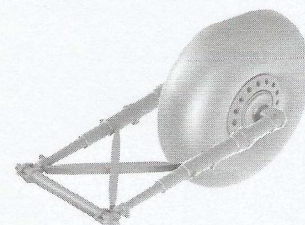
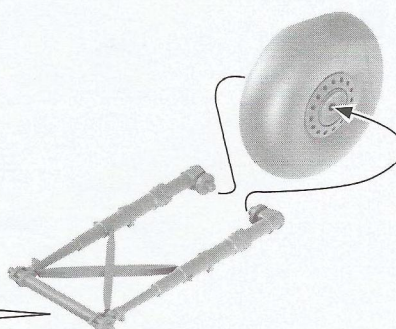
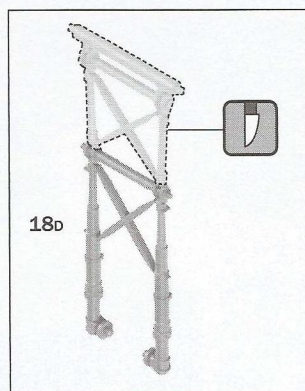

23

ALTERNATIVE  
EXTENDED LANDING GEAR

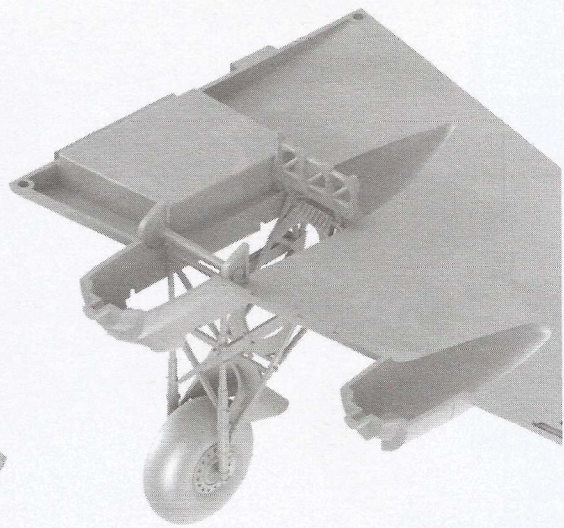
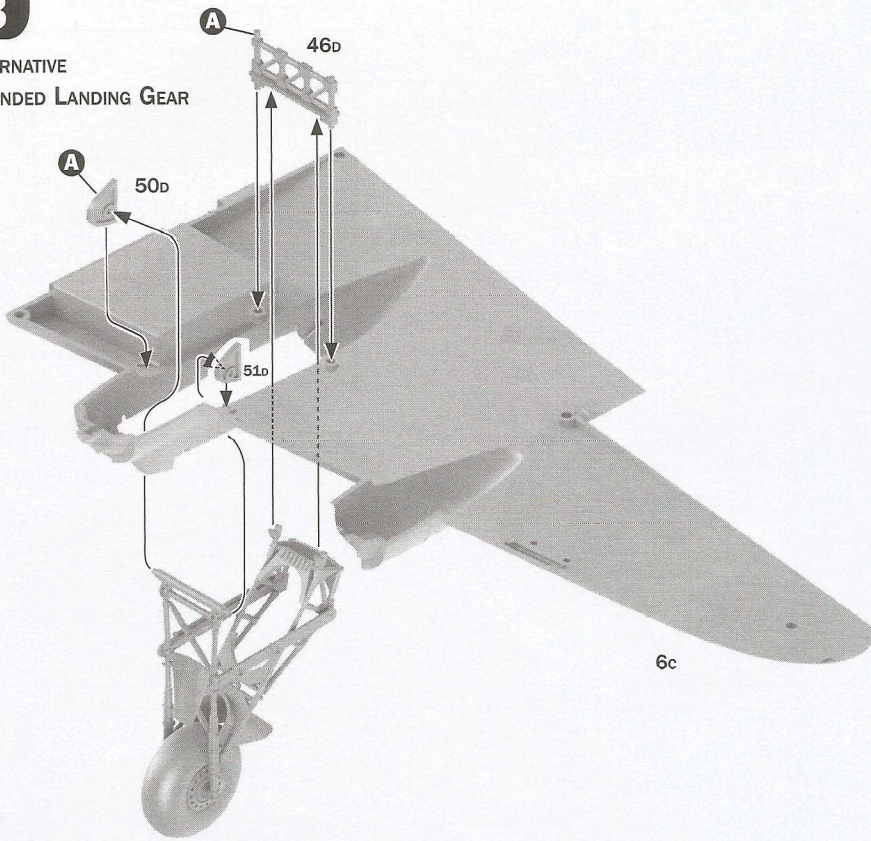

24

ALTERNATIVE  
EXTENDED LANDING GEAR

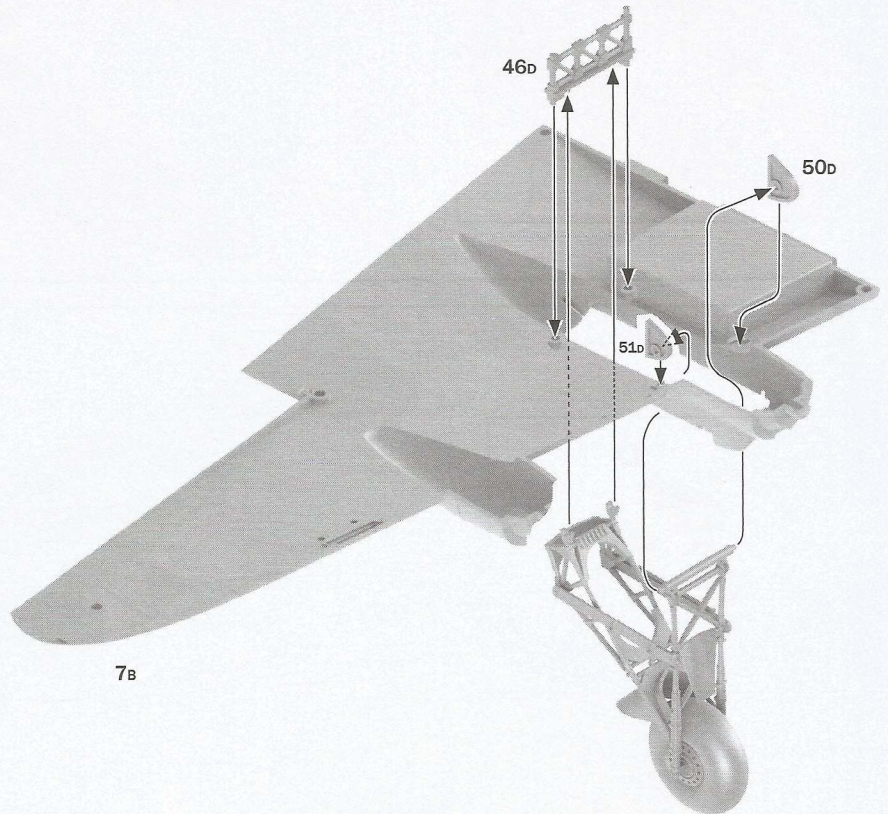
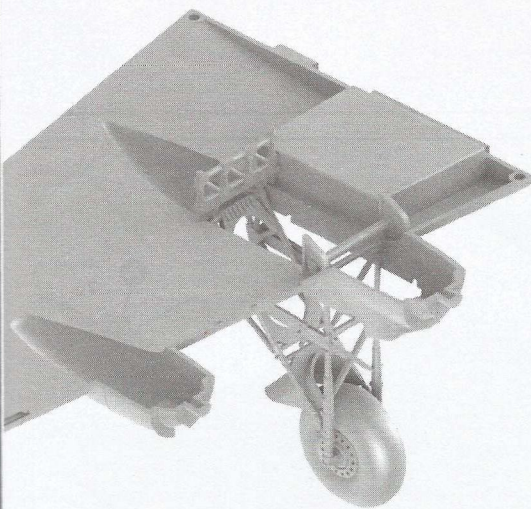

25

2x

ALTERNATIVE  
RETRACTED  
LANDING GEAR

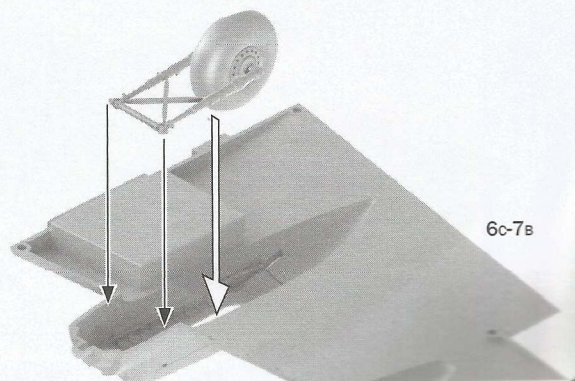
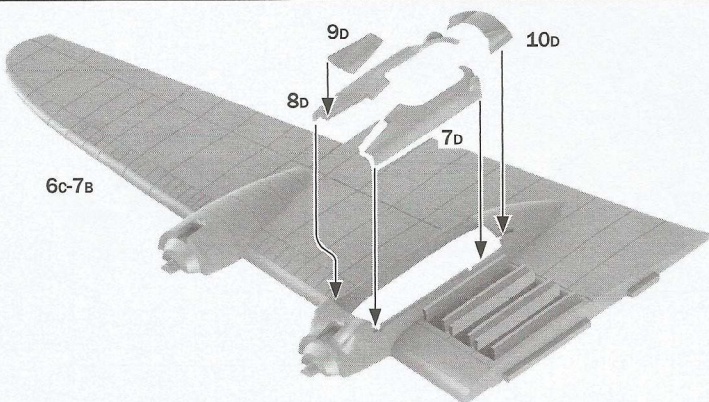

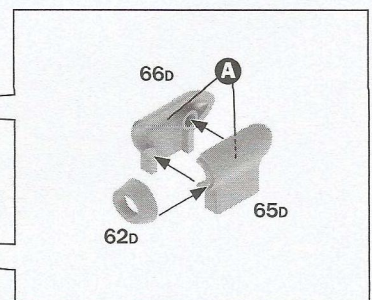
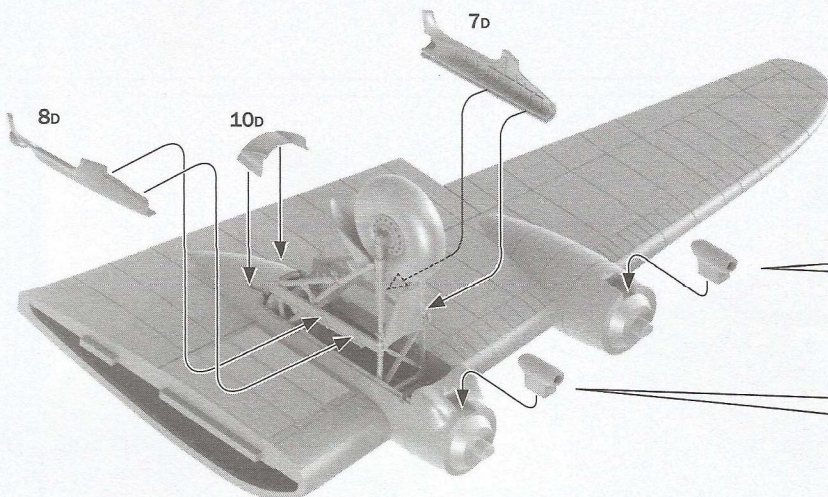
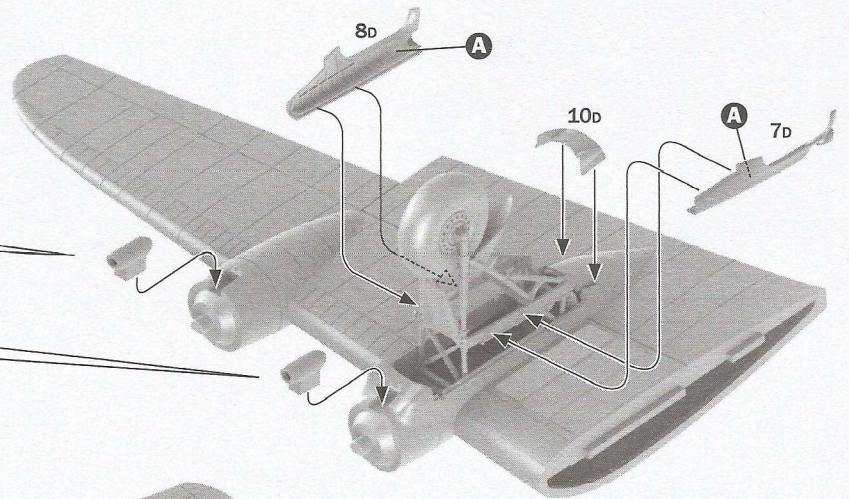
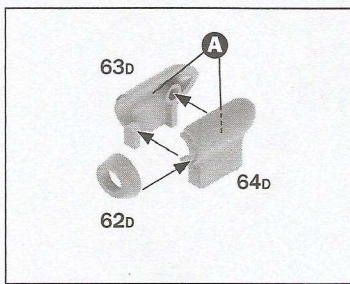
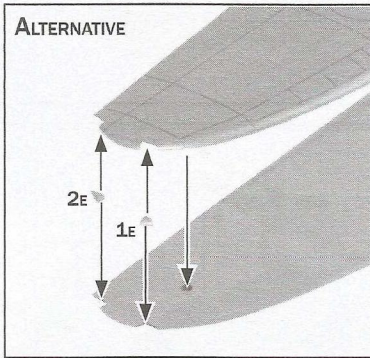
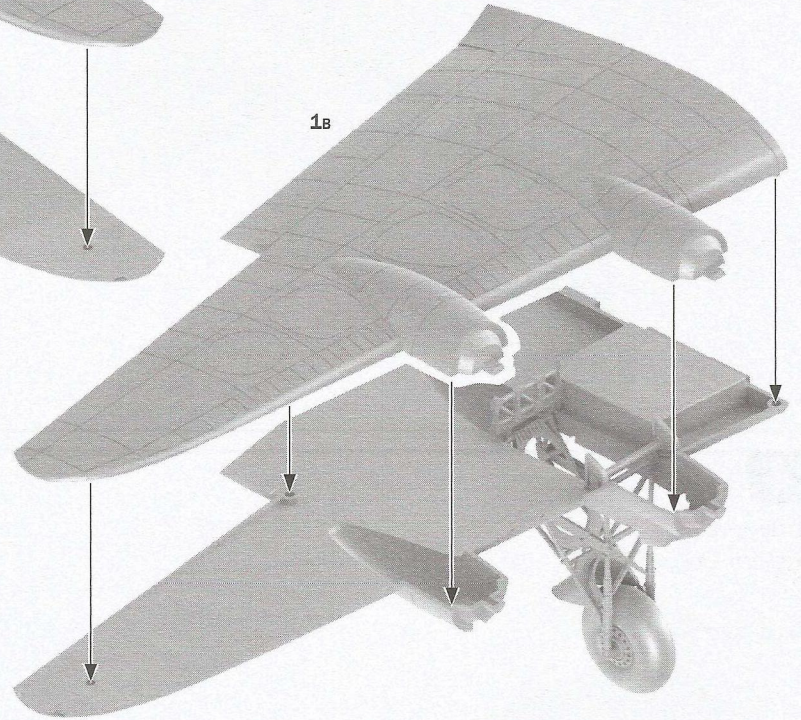
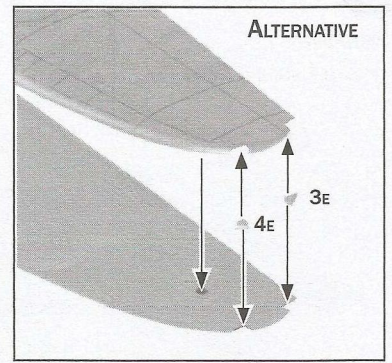
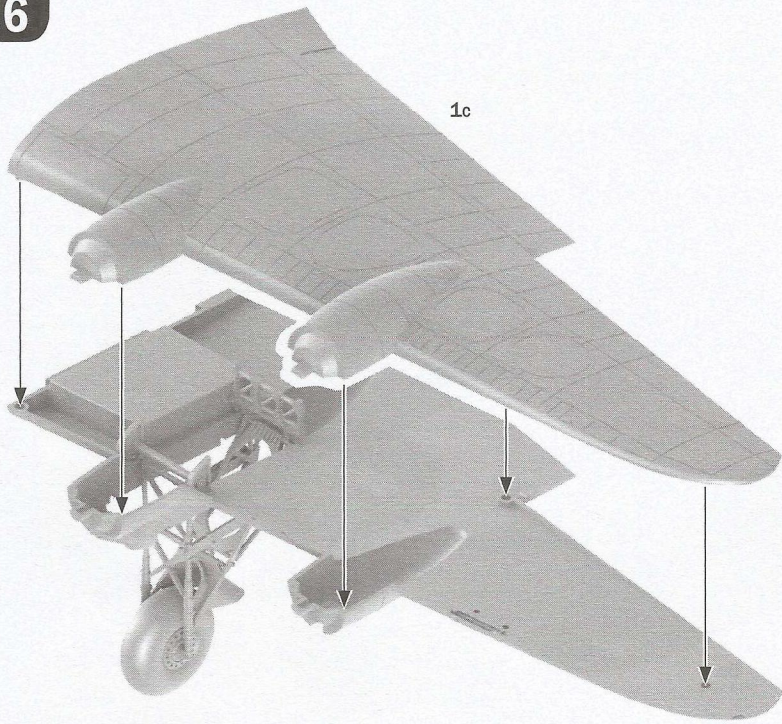



28 4x

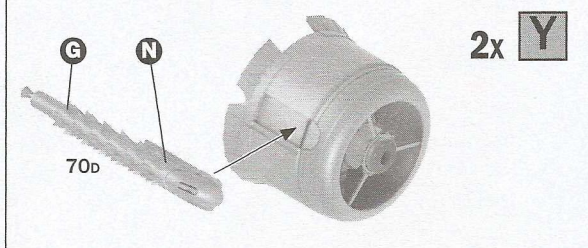
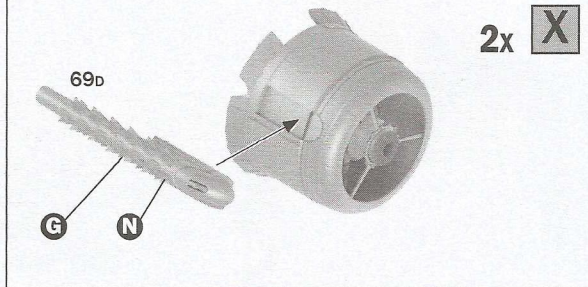
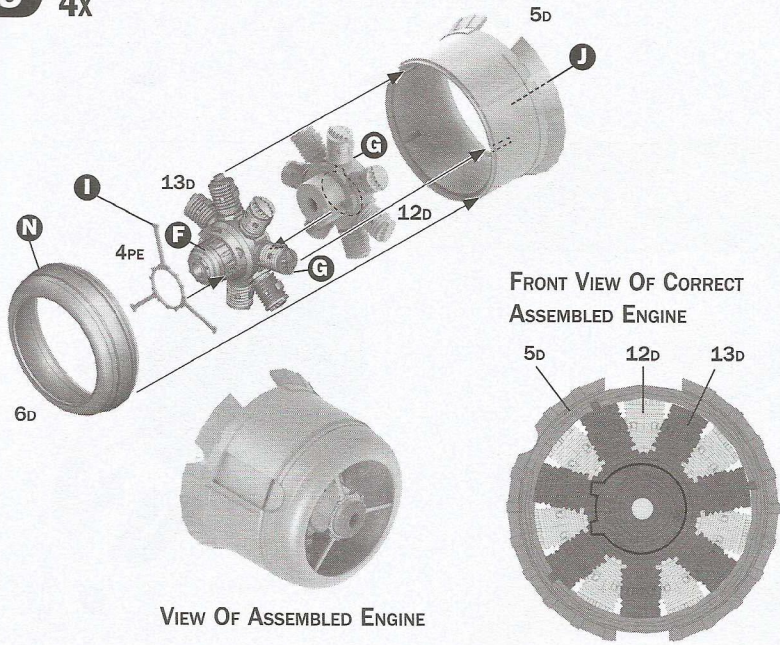

29

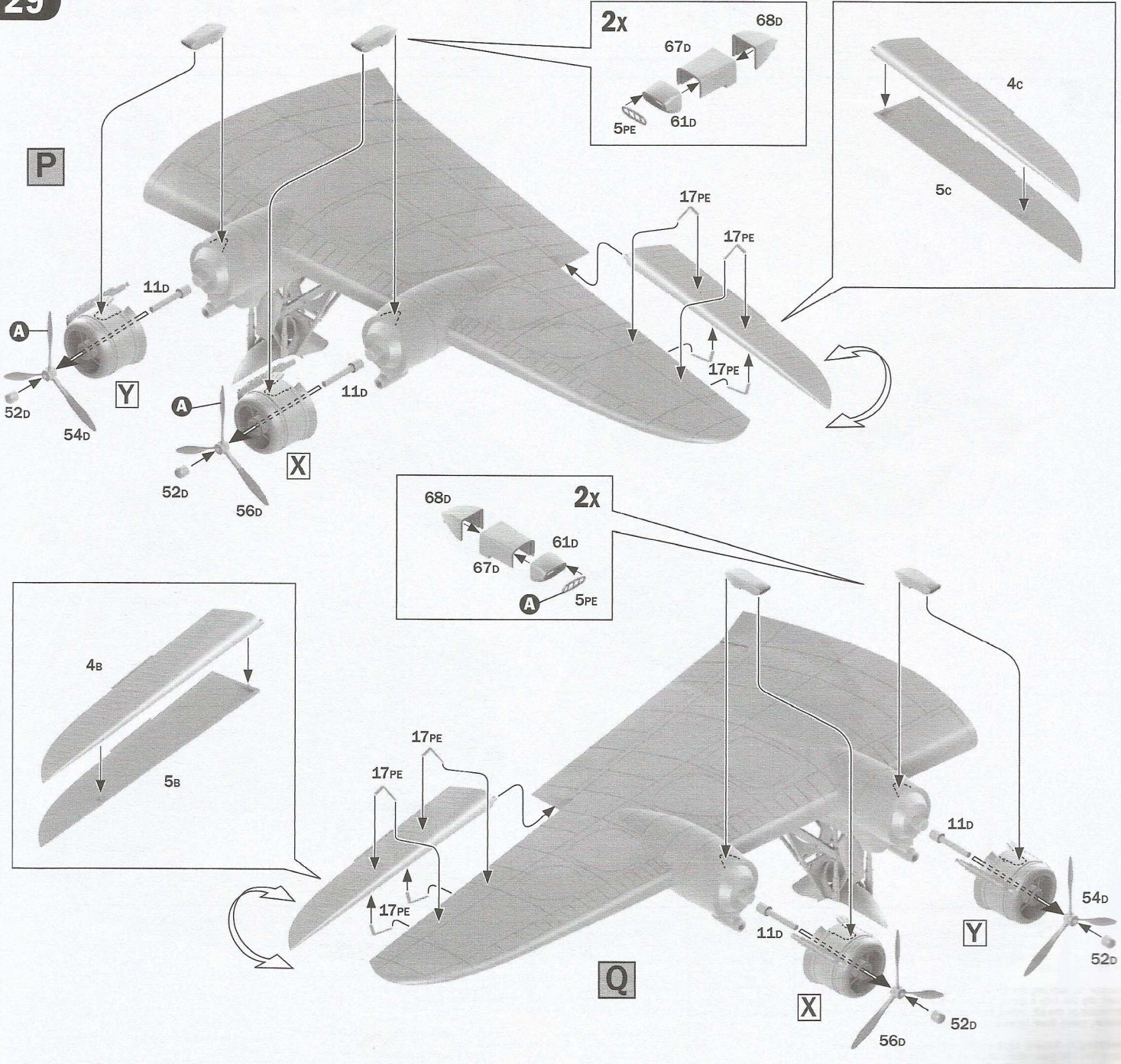

30

R

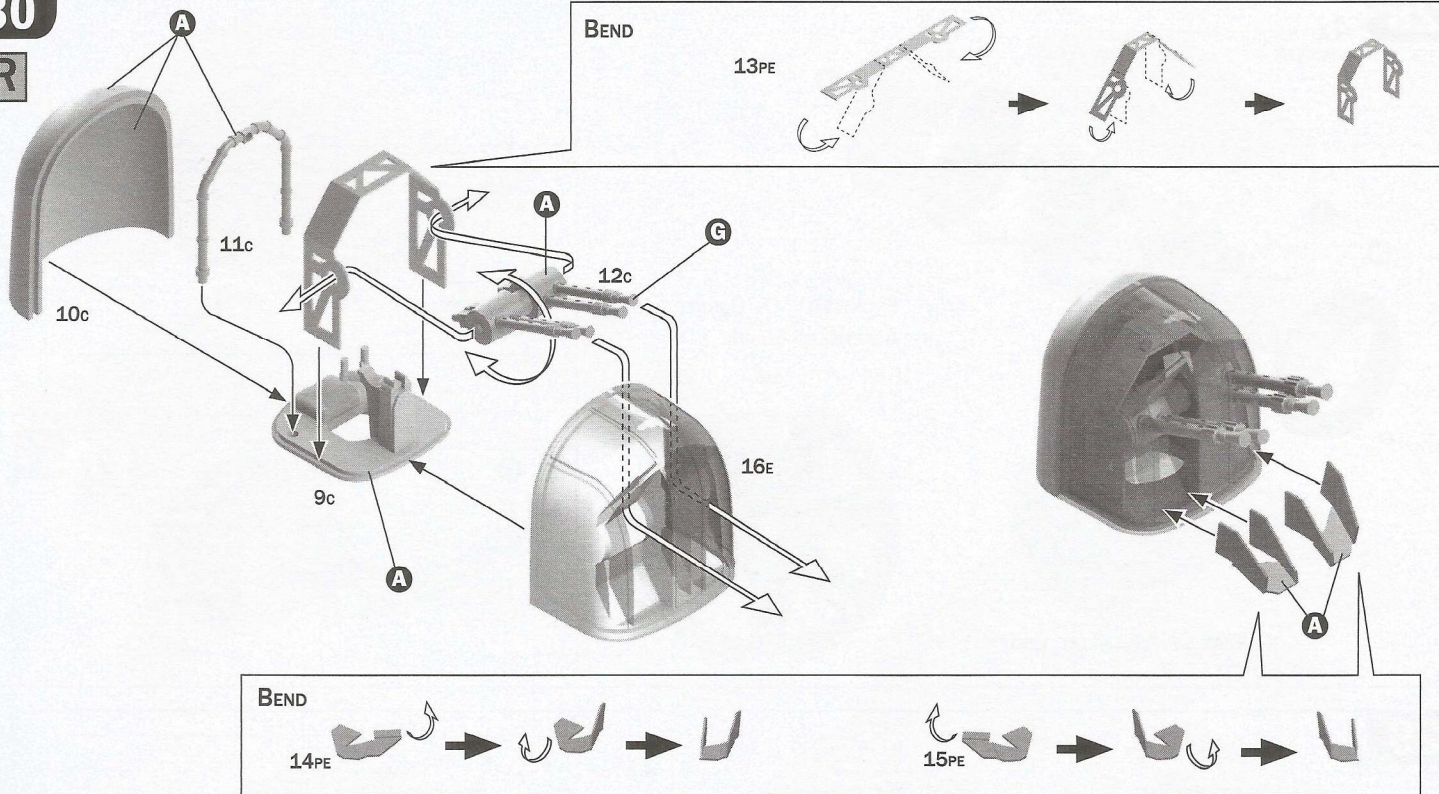

31

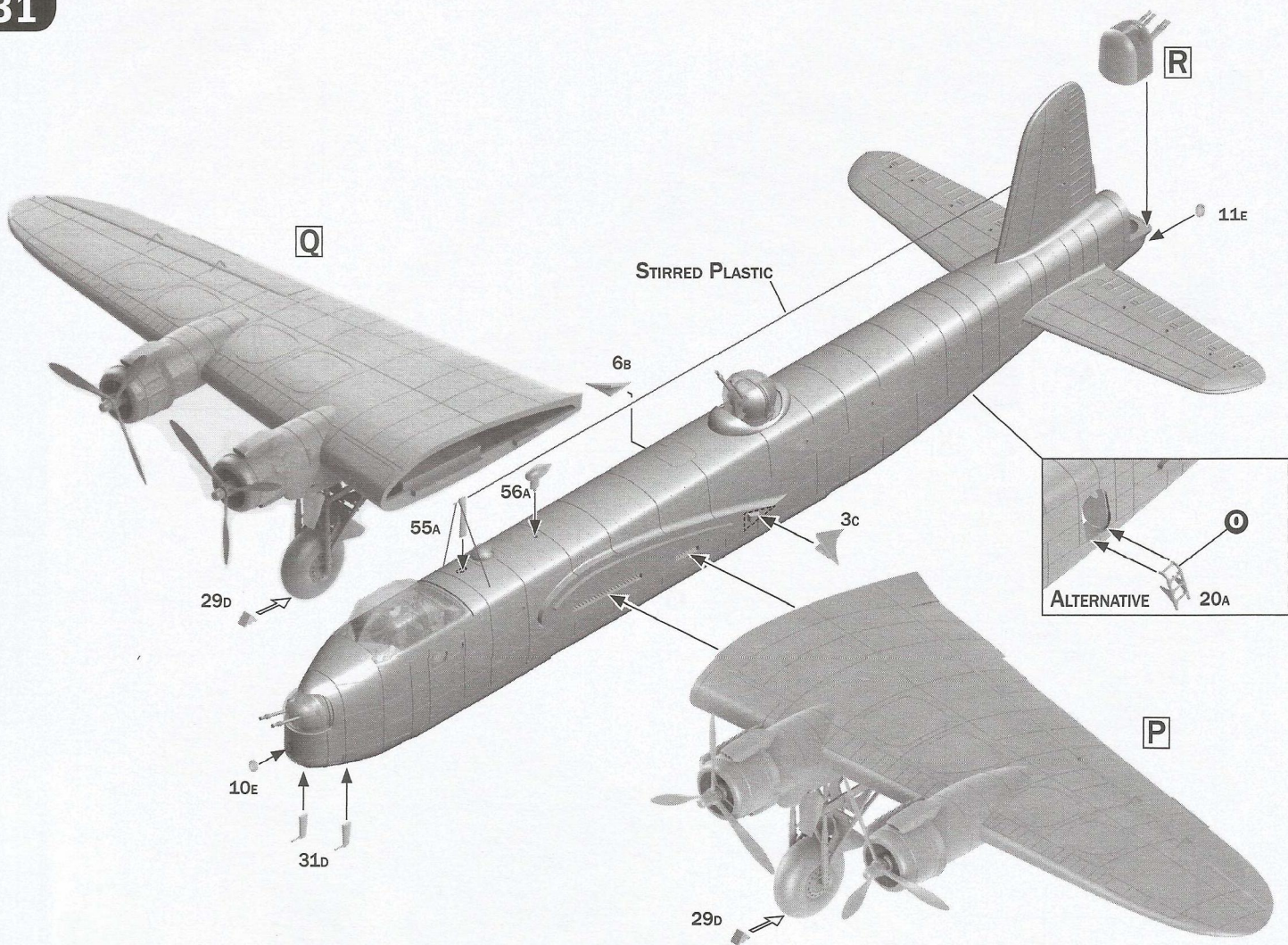

Istruzioni per l'applicazione delle decalcomanie. Ritagliare le decalcomanie occorrenti dal foglio, immergerle in un bicchiere di acqua pulita per circa 20", metterle in posizione sul modello e farle scivolare dalla carta: per una migliore aderenza comprimerle con una pezzuola pulita.

Direction for applying the decals: cut the required decals out of the sheet; dip the into a glass of clean water for about 20"; position the decals on the kit, letting them slide from the paper. For a better adhesion, press them by means of a clean rag.

Påläggning av decaler: klipp ut den decal som skall användas och doppa den i ett glas vatten under en 20". Sätt decalen på plats på modellen och låt den sakta glida av pappret. För att den skall sitta ordentligt, tryck till med en torr duk.

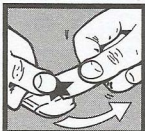

Anweisungen für Abziehbilder-Anbringung: Die benötigten Abziehbilder vom Blatt abscheiden, in ein Glas reines Wasser für etwa 20" eintauchen, auf das Modell legen und dann vom Papierbogen abnehmen. Um eine bessere Haftung zu erzielen, die Abziehbilder mit einem reinen Tuch andrücken.

Instruction pour l'application des décalcomanies. Couper les décalcomanies choisies et les plonger environ 20" dans un peu d'eau propre. Les placer sur le modèle en les faisant glisser de leur feuille et presser avec un morceau de chiffon pour éliminer les bulles d'air.

Istrucciones Para la aplicación de las calcomanías: cortar las requeridas, sumergirlas en un recipiente de agua limpia durante 20", colocar las calcomanías sobre el modelo, haciéndolas deslizar sobre el papel. Para una mejor adherencia, presionarlas con un trapito limpio.

Transfers: knip het benodigde deel uit, dempel et ca. 20" onder water, duid het transfer tegen het model en schuif het vanaf het papier op zijn plaats. Met een schoon doekje aandrukken.

デカール使用法 台紙から、それぞれのマークを切り取ります。ぬるま湯に20秒くらいつけて、引き上げます。マークをすべらすようにして台紙からとり、指定の位置にはってください。やわらかな布でマーク上を押しつけて気泡を取ってください。マーク面には、かわくまで手をふれないでください。

Указания по применению декалей: Отрежьте нужную вам часть декали от общего листа, поместите ее на 20" минуты в чистую воду, затем, выбрав необходимое место на модели, переведите туда изображение, сдвинув его с бумажной основы. Для лучшего прилипания промакните декаль чистой тряпочкой.

VERSION A: Short Stirling Mk.III L J525, EX-R "Jolly Roger"  
 RAF 199th Squadron, North Creake AB, UK 1944

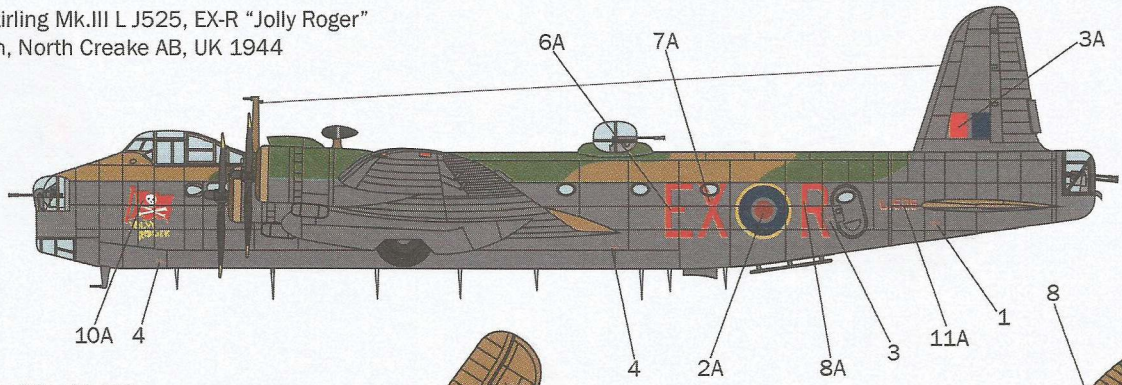

**"MANDREL" ECM SISTEM**

For placement of antennas see aircraft profile, following the centerline of the fuselage

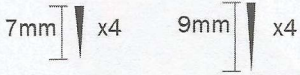

**TEMPLATE FOR THE CHUTE OF "WINDOWS" STRIPES**

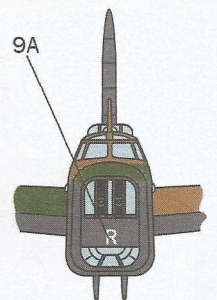
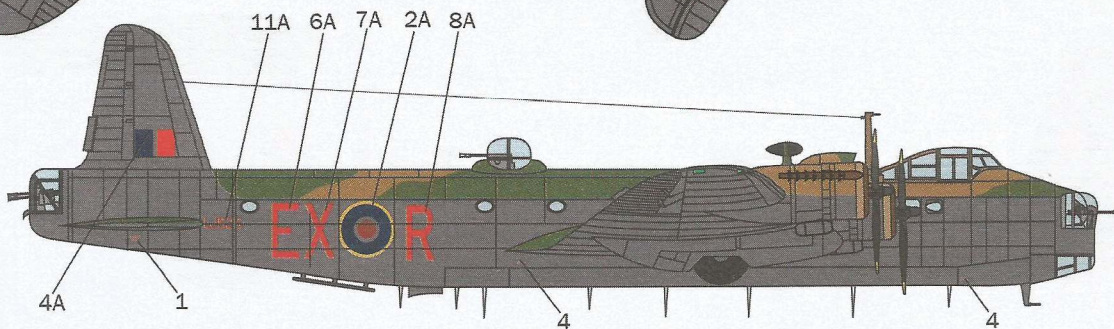
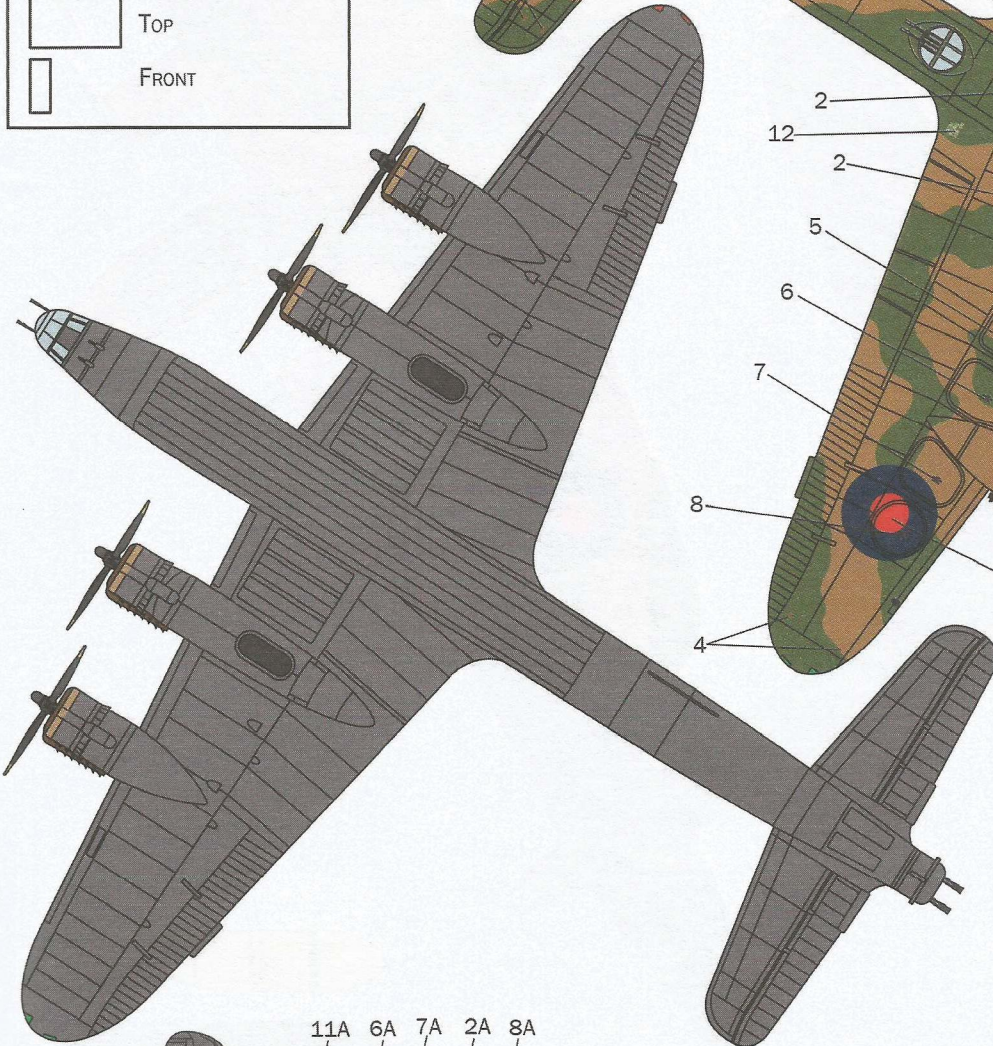
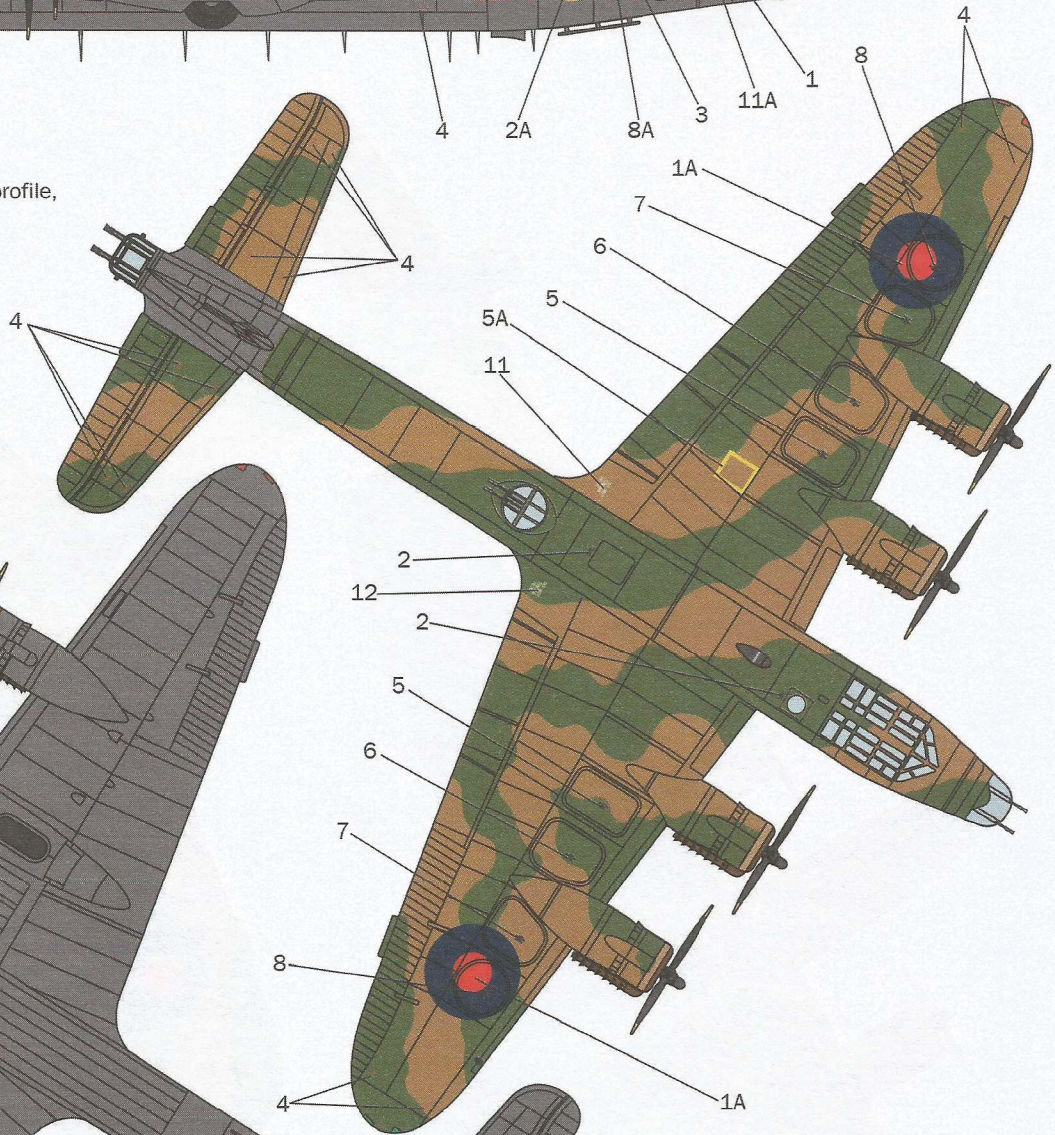
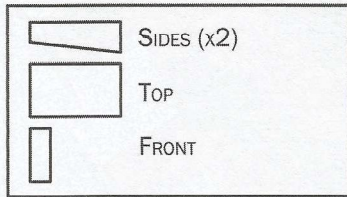

- Flat Dark Green  
4726AP  
F.S. 34079
- Flat Dark Earth  
4303AP  
F.S. 30118
- F Black  
4768AP  
F.S. 37038

VERSION B: Short Stirling Mk.III L J542, "Gremlin Teaser"  
 RAF 199th Squadron, North Creake AB, UK 1944

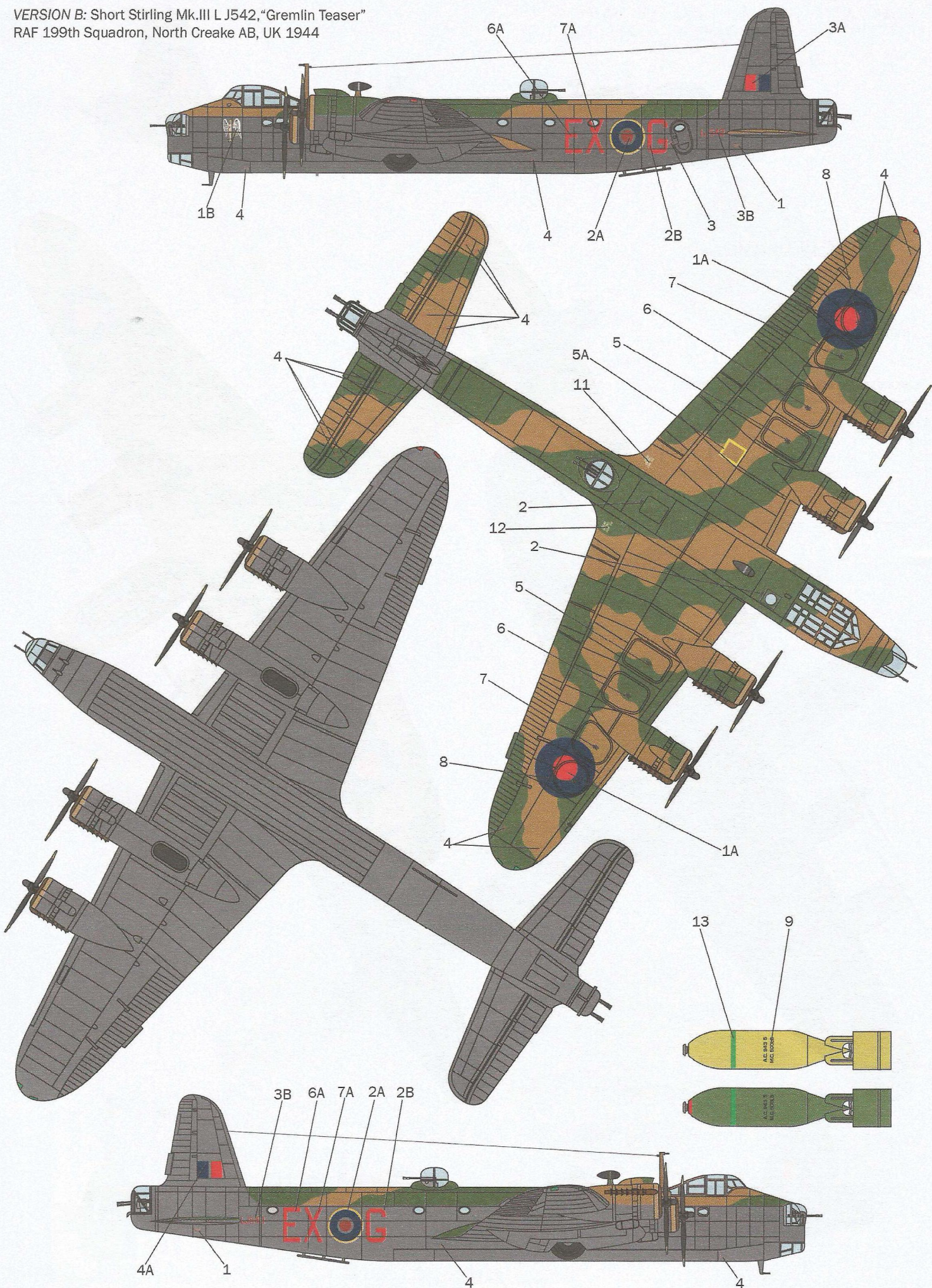

- |   |   |  |
|---|---|--|
| <div style="display: flex; align-items: center;"> <div style="width: 20px; height: 20px; background-color: #38761d; margin-right: 5px;"></div> <div> <p>Flat Dark Green<br/>4726AP<br/>F.S. 34079</p> </div> </div> | <div style="display: flex; align-items: center;"> <div style="width: 20px; height: 20px; background-color: #8b4513; margin-right: 5px;"></div> <div> <p>Flat Dark Earth<br/>4303AP<br/>F.S. 30118</p> </div> </div> | <div style="display: flex; align-items: center;"> <div style="width: 20px; height: 20px; background-color: #444; margin-right: 5px;"></div> <div> <p>F Black<br/>4768AP<br/>F.S. 37038</p> </div> </div> |
|---|---|--|



- |  |  |   |
|--|--|---|
| <div style="display: inline-block; width: 20px; height: 20px; background-color: #38761d; border: 1px solid black; margin-bottom: 5px;"></div> <p>Flat Dark Green<br/>4726AP<br/>F.S. 34079</p> | <div style="display: inline-block; width: 20px; height: 20px; background-color: #8b4513; border: 1px solid black; margin-bottom: 5px;"></div> <p>Flat Dark Earth<br/>4303AP<br/>F.S. 30118</p> | <div style="display: inline-block; width: 20px; height: 20px; background-color: #444; border: 1px solid black; margin-bottom: 5px;"></div> <p>F Black<br/>4768AP<br/>F.S. 37038</p> |
|--|--|---|

VERSION E: Short Stirling Mk.III EF403/G  
 RAF 1660th Conversion Unit, Swinderby AB, UK September 1943

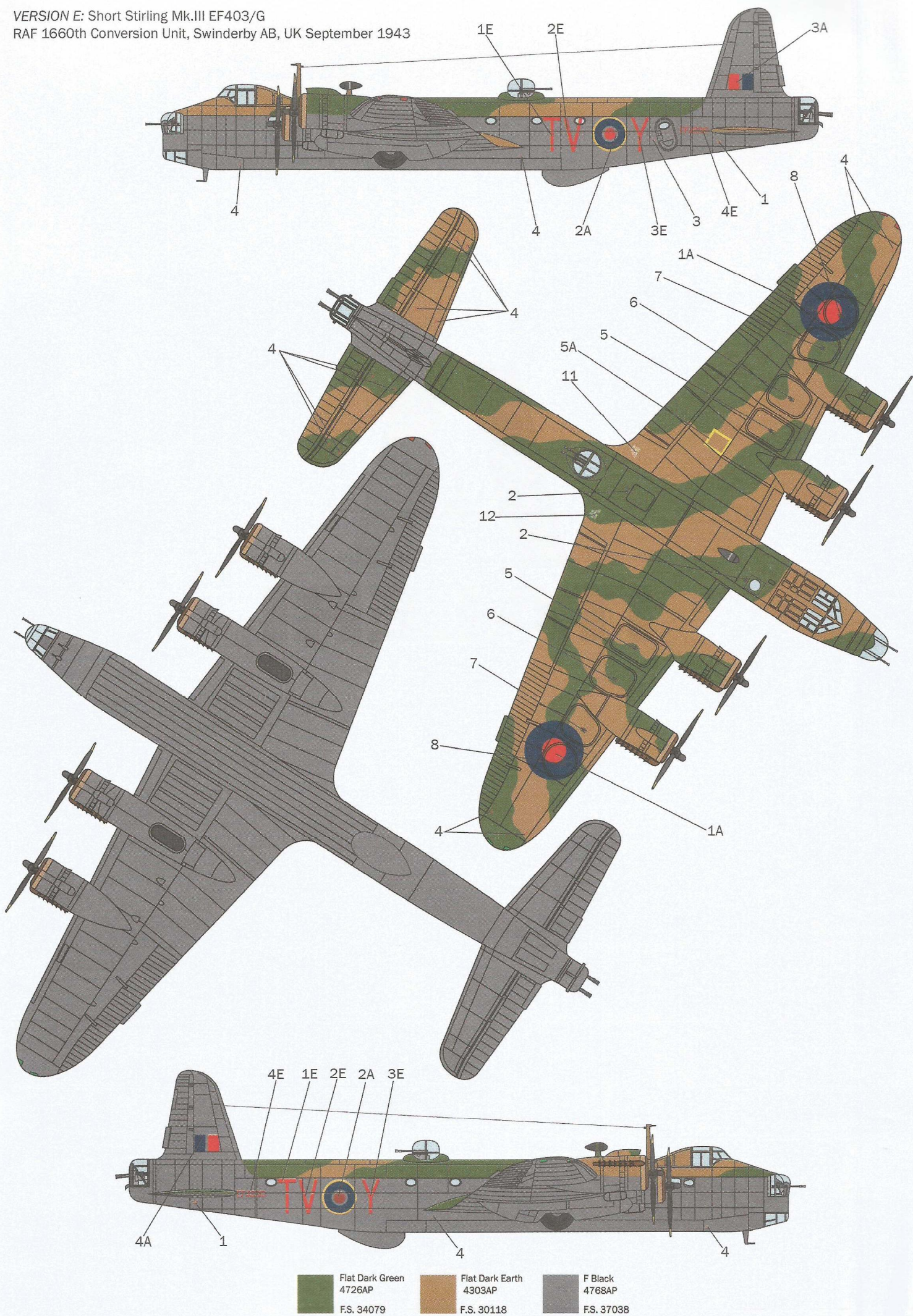

- |  |  |  |
|--|--|--|
| <p>Flat Dark Green<br/>4726AP<br/>F.S. 34079</p> | <p>Flat Dark Earth<br/>4303AP<br/>F.S. 30118</p> | <p>F Black<br/>4768AP<br/>F.S. 37038</p> |
|--|--|--|

**PE**

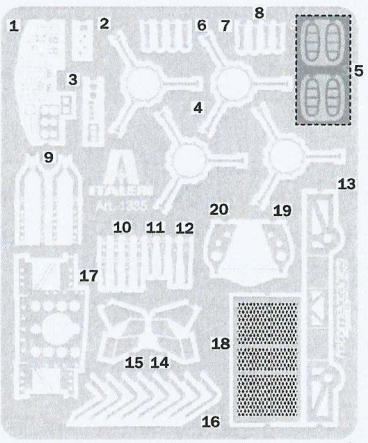

Parti da non utilizzare  
Parts not for use  
Pièces à ne pas utiliser  
Teile werden nicht verwenden

**29**

**Repeat On The Other Side**

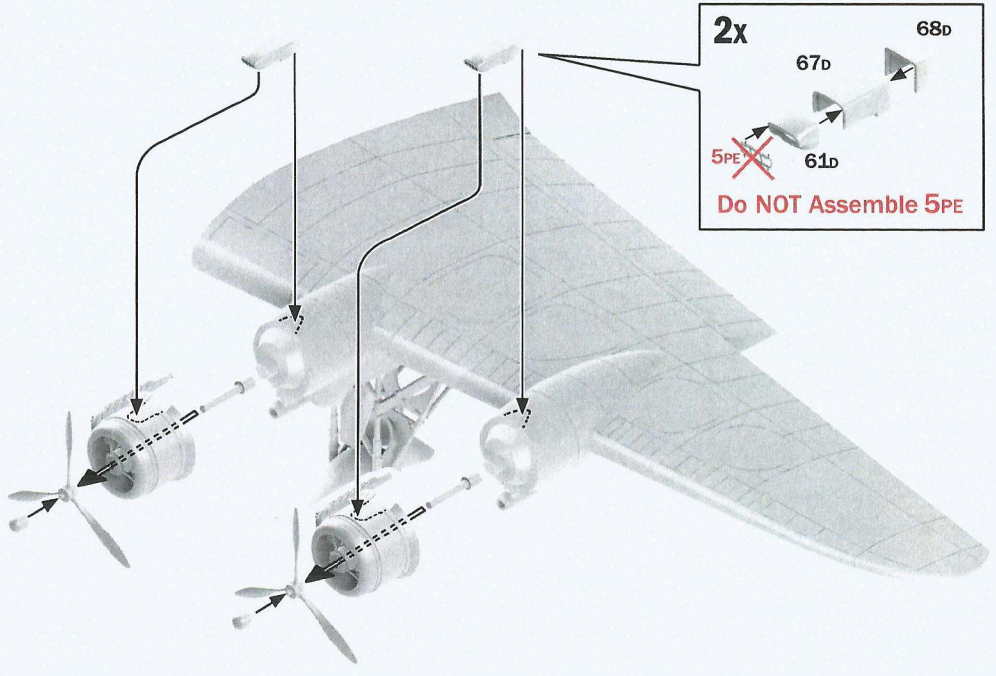

**2x**

67b 68d

5PE ~~X~~ 61b

**Do NOT Assemble 5PE**