



# 1:72 Blackburn Buccaneer S.2B

A06022 SCALE MODEL CONSTRUCTION KIT | Wingspan: 186mm Fuselage Length: 268mm | Two Decal Schemes Included | Two Build Options

EN

The mighty Buccaneer was one of the most capable low-level strike aircraft of the Cold War period, originally entering Royal Navy service in 1962 to counter the significant threat of a massive Soviet Naval expansion programme. British thinking at the time was to use their new strike jet to destroy the Soviet ships with a combination of conventional and nuclear weapons. Capable of extremely high speeds at low level, the Buccaneer proved to be ideal even though the performance of the first Buccaneers to enter service was affected by a lack of power from their two de Havilland Gyron Junior engines. Addressing most of the issues which prevented the early aircraft from realizing their full potential, the Buccaneer S.2 was a much improved platform, boasting a modified wing, increased fuel capacity and a pair of powerful Rolls Royce Spey engines. This new variant provided the Fleet Air Arm with a truly exceptional strike aircraft, which excelled in the low-level environment. As the Royal Navy retired their larger carriers in 1978, their much-loved Buccaneers were transferred to the care of the Royal Air Force, who were already admirers of the many qualities possessed by this aircraft and grateful for

FR

Pendant la période de la guerre froide, le formidable Buccaneer était l'un des appareils d'attaque à basse altitude les plus performants. Il entra en service au sein de la Royal Navy en 1962 afin de faire face à la menace considérable d'un vaste programme d'expansion de la marine soviétique. À cette époque, l'approche britannique était d'utiliser le nouvel avion d'attaque pour détruire les navires soviétiques avec les armes conventionnelles ainsi que nucléaires. Capable d'atteindre des vitesses extrêmement élevées à basse altitude, le Buccaneer s'est avéré être idéal même si les performances des premiers Buccaneer mis en service ont été affaiblies par le manque de puissance de leurs deux moteurs de Havilland Gyron Junior. Tout en réglant la plupart des problèmes qui empêchaient les premiers avions de réaliser leur plein potentiel, le Buccaneer S.2 était une plate-forme nettement améliorée, dotée d'une voilure modifiée, d'une capacité de carburant accrue et de deux puissants moteurs Rolls Royce Spey. Cette nouvelle variante a fourni à l'Aéronavale britannique un avion de frappe vraiment exceptionnel qui excellait dans des environnements à basse altitude. Lorsque le Royal Navy s'est séparé de ses plus gros porte-avions en 1978,

DE

Die beeindruckende Buccaneer war eines der leistungsfähigsten Tiefangriffslflugzeuge im Kalten Krieg. Sie wurde zum ersten Mal 1962 in der Royal Navy in Dienst gestellt, um der großen Gefahr, die das massive Erweiterungsprogramm der sowjetischen Marine darstellte, entgegenzuwirken. Nach den damaligen Vorstellungen der Briten sollte ihr neuer Angriffsjet dazu verwendet werden, sowjetische Schiffe mit einer Kombination aus konventionellen und Nuklearwaffen zu zerstören. Die Buccaneer konnte sehr hohe Geschwindigkeit im Tiefflug erreichen und erwies sich so als ideal, auch wenn die Leistung der ersten Buccaneer, die in Dienst gestellt wurden, unter den beiden schwachen de Havilland Gyron Junior-Triebwerken litt. Nach Behebung der Probleme, aufgrund derer die erste Version des Flugzeug ihr volles Potential nicht ausschöpfen konnte, stellte die Buccaneer S.2 eine stark verbesserte Plattform dar. Sie verfügte über modifizierte Flügel, verminderten Treibstoffverbrauch und zwei leistungsfähige Rolls Royce Spey-Triebwerke. Diese neue Version bot der Marineflottilie ein wirklich außergewöhnliches Kampfflugzeug, das im Tiefflug Herausragendes leistete. Als die Royal Navy ihre großen Flugzeugträger in 1978 ausmusterte, wurden ihre geliebten Buccaneer in die Obhut der Royal Air Force übergeben. Diese hatte schon immer die vielen Qualitäten dieses Flugzeugs bewundert und war dankbar für diesen Zugang zu ihrer

ES

El potente Buccaneer fue uno de los más capaces aviones de ataque a baja altura del periodo de la Guerra Fría y entró en servicio en la Royal Navy en 1962 en respuesta a la amenaza de un masivo programa soviético de expansión naval. En aquel momento, la idea del gobierno británico era utilizar el nuevo reactor de ataque para destruir navíos soviéticos con una combinación de armas convencionales y nucleares. Capaz de alcanzar velocidades extremadamente elevadas a baja altura, el Buccaneer demostró ser ideal, incluso aunque las prestaciones de los primeros aparatos en servicio se vieron afectadas por la insuficiente potencia de los dos motores de Havilland Gyron Junior. El Buccaneer S.2 solventó muchos de los problemas que impedían a la primera versión alcanzar todo su potencial y era una plataforma muy mejorada, con modificaciones en las alas, mayor capacidad de combustible y dos potentes motores Rolls Royce Spey. Esta nueva variante proporcionó al Fleet Air Arm un avión de ataque verdaderamente excepcional, que sobresalía en bajas alturas. Cuando la Royal Navy retiró en 1978 sus portaaviones más grandes, sus venerados Buccaneers pasaron al cuidado de la Royal Air Force, que ya conocía y admiraba las muchas cualidades de este aparato y aceptó de muy buen grado este nuevo elemento en su inventario. En

SV

Buccaneer var ett av de mest kapabla och robusta attackflygplanen på hög höjd under det kalla kriget. Det sattes in i brittiska Royal Navy 1962 i syfte att möta det signifikativa hot som den sovjetiska flottexpansionen utgjorde. Britterna avsåg vid denna tid att använda sitt nya attackflygplan till att sänka ryska skepp med en kombination av konventionella vapen och kärnvapen. Buccaneer flög med hög hastighet på låg nivå och visade sig vara idealisk för sin uppgift, trots att de första Buccaneer-planen som insattes hämmades av låg effekt i de två de Havilland Gyron Junior-motorerna. De flesta problem som förhindrade den tidiga varianten att nå full potential åtgärdades i och med Buccaneer S.2, en mer avancerad plattform med en modifierad vinge, ökad bränslekapacitet och två kraftiga Rolls Royce Spey-motorer. Denna nya variant försåg Fleet Air Arm med ett kapabelt attackflygplan som uppvisade imponerande resultat på låg nivå. När Royal Navy pensionerade sina större hangarfartyg 1978 överfördes de ättråvärda Buccaneer-planen till Royal Air Force, som länge hade beundrat flygplanets kvalitativa funktioner

this increase in their inventory. At its peak strength in the early 1970s, the Buccaneer equipped no fewer than six Royal Air Force Squadrons.

### Specification

Maximum Speed: 667 mph (1,074 km/h)

Wingspan: 44 ft 0 in (13.41m)

Length: 63 ft 5.0 in (19.33 m)

Armament: Various combinations of unguided bombs, laser-guided bombs and Red Beard or WE.177 tactical nuclear bombs up to 4,000 lb (1,814 kg) on wing pylons and up to 12,000 lb (5,443 kg) in internal bomb bay. 4 × Matra rocket pods. 2 × AIM-9 Sidewinders or 2 × AS-37 Martel missiles, or 4 × Sea Eagle missiles.

leurs très populaires Buccaneer ont été reversés à la Royal Air Force, déjà admiratrice des nombreux atouts de cet appareil et reconnaissante de l'augmentation de leur flotte. Lors de son pic de production atteint au commencement des années 1970, le Buccaneer a équipé pas moins de six escadilles de la Royal Air Force.

### Spécification:

Vitesse maximale: 1.074 km/h

Envergure: 13,41 m

Longueur: 19,33 m

Armement: Diverses combinaisons de bombes non guidées et guidées laser, et de bombes nucléaires tactiques Red Beard ou WE.177, jusqu'à 1.814 kg fixées aux mâts d'ailes et jusqu'à 5.443 kg dans la soute à bombes interne. Quatre nacelles lance-roquettes Matra. Deux missiles AIM-9 Sidewinder ou deux missiles AS-37 Martel ou quatre missiles Sea Eagle.

Ausrüstung. Auf der Höhe ihres Einsatzes Anfang der 1970er Jahre war die Buccaneer in nicht weniger als sechs Royal Air Force Squadrons eingesetzt.

### Spezifikation:

Höchstgeschwindigkeit: 1074 km/h

Spannweite: 13,41 m

Länge: 19,33 m

Bewaffnung: Unterschiedliche Kombinationen von ungelenkten Bomben, lasergelenkten Bomben und Red Beard oder WE.177 taktische Nuklearbomben von bis zu 1814 kg auf Rumpfpylonen und von bis zu 5443 kg im internen Waffenschacht. 4 × Matra Rohrstartbehälter. 2 × AIM-9 Sidewinders oder 2 × AS-37 Martel Lenkflugkörper, oder 4 × Sea Eagle Lenkflugkörper.

su momento de mayor esplendor, a comienzos de la década de 1970, el Buccaneer equipaba no menos de seis escuadrones de la Royal Air Force.

### Especificación:

Velocidad máxima: 1074 km/h

Envergadura: 13,41 m

Longitud: 19,33 m

Armamento: Distintas combinaciones de bombas no dirigidas, bombas dirigidas por láser y bombas nucleares tácticas Red Beard o WE.177, hasta 1814 kg en pilones en las alas y hasta 5443 kg en el compartimento interno. 4 lanzacohetes Matra. 2 misiles AIM-9 Sidewinder o 2 AS-37 Martel, o bien 4 misiles Sea Eagle.

och tacksamt tog emot det senaste tillskottet i sin arsenal. Vid planetens storhetstid i början på 1970-talet försågs inte mindre än sex Royal Air Force-divisioner med Buccaneer.

### Spécification:

Maximal hastighet: 1 074 km/h

Spännvidd: 13,41 m

Längd: 19,33 m

Bestyckning: Olika kombinationer av icke styrda bomber, laserstyrda bomber och taktiska Red Beard- eller WE.177-atombomber upp till 1 814 kg på vingbalkar och upp till 5 443 kg i flygplanets bombtrum, fyra Matra-raketpodar, två AIM-9 Sidewinder eller två AS-37 Martel-robotar eller fyra Sea Eagle-robotar.

### FOR BEST RESULTS:

Surfaces to be painted should be clean — before parts are removed from the sprue, wash in warm, soapy water, rinse and dry thoroughly. Stir paints thoroughly before use.

### PLEASE NOTE:

Some parts in the kit may not be required to build the model specified.

**HORNBY  
HOBBIES**



Manufactured by: Hornby Hobbies Ltd Westwood, Margate, Kent, CT9 4JX, UK +44(0)1843 233525 customerservices.uk@hornby.com

EU Authorised Representative: Hornby Italia SRL Viale dei Caduti, 52/A6, Castel Mella (BS), Italy, 25030 +39 0687501292 customerservices.it@hornby.com

# ASSEMBLY INSTRUCTIONS

**EN** Study drawings and practise assembly before cementing parts together. Carefully scrape paint from cementing surfaces. All parts are numbered. Paint small parts before assembly. To apply decals cut sheet as required, dip in warm water for a few seconds, slide off backing into position shown. Use in conjunction with box artwork. Not appropriate for children under 36 months of age, due to the presence of small detachable parts.

**FR** Étudier attentivement les dessins et simuler l'assemblage avant de coller les pièces. Gratter soigneusement toute peinture sur les surfaces à coller. Toutes les pièces sont numérotées. Peindre les petites pièces avant l'assemblage. Pour coller les décalcomanies, découper le motif, le plonger quelques secondes dans de l'eau chaude puis le poser à l'endroit indiqué en décollant le support papier. Utiliser conjointement avec les illustrations sur la boîte. Ne convient pas aux enfants de moins de 36 mois – présence de petits éléments détachables.

**DE** Vor dem Zusammenkleben der Teile die Zeichnungen sorgfältig ansehen und die zu verklebenden Teile zur Vermeidung möglicher Fehler versuchsweise zusammenfügen. Dann an den Klebeflächen vorhandene Farbbeschichtung vor dem Zusammenkleben vorsichtig abkratzen. Alle Bestandteile sind mit Nummern versehen. Kleine Teile vor dem Zusammenbau bemalen. Abziehbilder wie gewünscht ausschneiden. Vor dem Anbringen einige Sekunden in warmes Wasser tauchen und dann vom Trägerpapier in ihre vorgesehene Position schieben. Dabei die Abbildungen auf der Schachtel beachten. Nicht für Kinder unter 36 Monaten geeignet, da abnehmbare bzw. lose angebrachte Kleinteile enthalten sind.

**ES** Estudiar los dibujos y practicar el montaje antes de pegar las piezas. Raspar cuidadosamente la pintura en las superficies de contacto antes de pegar las piezas. Todas las piezas están numeradas. Es conveniente pintar las piezas pequeñas antes de su montaje. Para aplicar las calcomanías, cortarlas de la hoja, sumergirlas en agua tibia durante unos segundos y deslizarlas a la posición indicada. Utilizar en conjunción con la ilustración de la caja. No es adecuado para niños menores de 36 meses, ya que contiene piezas pequeñas que podrían soltarse.

**SV** Studera bilderna noggrant och sätt ihop delarna innan du limmar ihop dem. Skrapa försiktigt bort färg från limmade delar. Alla delarna är numererade. Måla smådelarna före ihopsättning. Sätt fast dekalerna genom att klippa arket, doppa i varmt vatten några sekunder och låta baksidan glida på plats som bilden visar. Använd enligt bildanvisningarna på kartongen. Rekommenderas ej för barn under 3 år. Innehåller löstagbara smådelar.

**NL** Tekeningen bestuderen en delen in elkaar zetten alvorens deze te lijmen. Lak voorzichtig van lijmvlakken afschrapen. Alle delen zijn genummerd. Kleine delen vóór montage verven. Voor aanbrengen van stickers, gewenste stickers uit het vel knippen, een paar seconden in warm water dompelen en dan van het schutblad af op afgebeelde plaats schuiven. Hierbij afbeelding op doos raadplegen. Niet geschikt voor kinderen onder 3 jaar, omdat kleine deeltjes gemakkelijk kunnen losraken.

**PO** Przed przystąpieniem do sklejania przestudiuj uważnie rysunki i przećwicz składanie części. Ostrożnie zeskrób ze sklejanych powierzchni farbę. Wszystkie części są ponumerowane. Drobne części pomaluj przed ich złożeniem. Celem przeniesienia kalkomanii wytnij ją z arkusza, zanurz na kilka sekund w letniej wodzie i zsuń z podłoża na wymagane miejsce. Używaj w połączeniu ze wzorami na pudełku. W związku z obecnością wielu drobnych, rozbiernych części, nieodpowiednie dla dzieci poniżej 3 lat.

**IT** Studiare i disegni ed esercitarsi a montare i vari pezzi prima di fissarli con la colla. Raschiare con cura le tracce di vernice dalle superfici da incollare. Tutti i pezzi sono numerati. Verniciare i pezzi di piccole dimensioni prima di montarli. Per applicare le decalcomanie, ritagliare il foglio nel modo richiesto, immergere in acqua calda per alcuni secondi, quindi staccare la decalcomania dalla carta di supporto e posizionarla nel punto desiderato. Usare le decalcomanie come indicato nell'illustrazione riportata sulla confezione. Non adatto a bambini di età inferiore a 36 mesi per la presenza di componenti di piccole dimensioni che potrebbero staccarsi.

**PT** Estudar atentamente os desenhos e experimentar a montagem. Raspar cuidadosamente as superfícies de modo a eliminar pintura antes de colar. Todas as peças estão numeradas. Pintar as pequenas peças antes de colar. Para aplicar as decalcomanias, cortar as folhas e mergulhar em água morna por alguns segundos, depois deslizar e aplicar no respectivo lugar, como indicado nas ilustrações na caixa. Não convém a uma criança de menos de 36 meses devido à presença de pequenos elementos destacáveis.

**EL** Μελετήστε προσεκτικά τα σχέδια και συναρμολογήστε για πρώτη φορά τα κομμάτια χωρίς να τα συγκολλήσετε. Αφαιρέσετε επιμελώς την πλαστική βαφή από τις επιφάνειες τις οποίες θα συγκολλήσετε. Όλα τα κομμάτια είναι αριθμημένα. Χρωματίστε τα μικρά κομμάτια πριν από τη συναρμολόγηση. Για να κολλήσετε τις χαλκομανίες, κόψετε γύρω από το σχέδιο όπως απαιτείται, βυθίστε το μερικά δευτερόλεπτα σε χλιαρό νερό και μετά τοποθετήστε το στη θέση που υποδεικνύεται, αφαιρώντας τη μεμβράνη που το καλύπτει. Λάβετε υπόψη σας αυτόχρονα την εικονογράφηση του κουτιού. Ακατάλληλο για παιδιά ηλικίας κάτω των 36 μηνών λόγω ύπαρξης μικρών κομματιών που αποσπώνται.

**FI** Tutustu piirroksiin ja harjoittele kokoamista, ennen kuin liimaat osat yhteen. Raaputa maali varovasti pois liimattavilta pinoilta. Kaikki osat on numeroitu. Maalaa pienet osat ennen kokoamista. Siirtokuvien kiinnittämiseksi leikkaa ne arkista tarpeen mukaan. Kasta kuva lämpimään veteen muutaman sekunnin ajaksi, anna takapuolen liukua kuvalle osoitettuun kohtaan. Käytetään yhdessä laatikon kuvituksen kanssa. Ei suositella alle kolmivuotiaille lapsille. Paljon irrotettavia pikkuosia.

**DA** Studér tegningerne nøje og forsøg at sætte delene sammen, inden de klæbes sammen. Skrab forsigtigt malingen af de overflader, der skal klæbes sammen. Alle dele er nummererede. Små dele skal males, før de monteres. Overføringsbillederne påføres ved at klippe dem ud af arket, som påkrævet, dyppe dem i varmt vand i nogle få sekunder, hvorefter underlaget glides af i de viste positioner. Påføres ifølge illustrationerne på æsken. Ikke egnet til børn under 3 år på grund af tilstedeværelse af små aftagelige dele.

# ASSEMBLY ICON INSTRUCTIONS

<p>Assembly phase Phase de montage Montagephase Fase de montaje Monteringsfasen Fase di montaggio Montagefase Fase de montagem Monteringsfase Kokoamisvaihe Faza składowania Φάση συναρμολόγησης</p> 	<p>Cement Coller Kleben Kleben Pegar Limma Incollare Lijmen Colar Klæbes Liimaa Kleić Συγκολλήστε</p> 	<p>Do not cement together No pas coller Nicht kleben Nicht kleben No pegar Limma inte Non incollare Niet lijmen Não colar Skal ikke klæbes Älä liimaa Nie kleić Μη συγκολλήσετε</p> 	<p>Indicates final location Indique l'emplacement final Zeigt Endposition Zeigt Endposition Indica la ubicación definitiva Anger slutmonteringsplats Sede di montaggio finale Geeft uiteindelijke locatie aan Indica localização final Viser endelig placering Osoittaa lopullisen sijainnin Oznacza miejsce docelowe Υποδεικνύει τελική τοποθεσία</p> 	<p>Alternative part(s) provided Autre(s) pièce(s) fournie(s) Ersatzteil(e) mitgeliefert Se incluye(n) pieza(s) alternativa(s) Alternativ(a) del(ar) ingår Uno o più componenti alternativi forniti Alternatieve onderdelen meegeleverd Peça(s) alternativa(s) fornecida(s) Alternativ(e) del(e) medfølger Vaihtoehtoiset osat pakkauksessa Dostępne części zamiennie Παρέχονται εναλλακτικά κομμάτια</p> 	<p>Repeat this operation Répéter l'opération Wiederholen Vorgang wiederholen Repètir la operación Upprepa åtgärden Ripetere l'operazione De verrichting herhalen Repètir a operação Manøveren gentages Toista toimenpite Powtórzyc operację Επανάλαβε τη διαδικασία</p> 	
<p>Decals Décalcomanies Abziehbild Calcomanias Dekaler Decalcomanie Stickers Decalcomania Billedoverføring Siirtokuvat Kalkomanie Χαλκομανίες</p> 	<p>Crystal part Pièce cristal Kristallteil Pieza de cristal Kristalidel Pezzo cristallo Kristallen onderdeel Peça de cristal Kristalstykke Kristalliosa Część kryształowa Κομμάτι κρυστάλλου</p> 	<p>Weight Lester Beschweren Lastrar Belasta Applicare un peso Verzwaren Lastrar Påfør vægt Aseta vastapaino Obciążyć balastem Επιθέστε βάρος</p> 	<p>Remove by filing Enlever avec une lime Abfeilen Abfeilen Eliminar con lima Ta bort genom att fila Rimuovere con la lima Verwijderen door afvijlen Remove limando Fjern ved at file væk Poista villaamalla Usunąć przy użyciu pilnika Αφαιρέστε λιμόφραση με λίμα</p> 	<p>Drill or pierce Perçer Durchbohren Perforar Borra Trapanare o forare Boren of doorboren Furar Gennembor Poraa tai puhkaise Wywierć lub przedziurawić Τρυπήστε</p> 	<p>Cut Découper Schneiden Cortar Skär Tagliare Snijden Cortar Skær Leikkaa Przeciąć Κόψτε</p> 	<p>Humbrol paint number No peinture Humbrol Humbrol-Farbnnummer No de pintura Humbrol Humbrol färg nummer No vernice Humbrol Humbrol verfunnummer No de pintura Humbrol Humbrol malingsnummer Humbrol-maaln numero Nr farby Humbrol Νούμερο χρώματος Humbrol</p> 

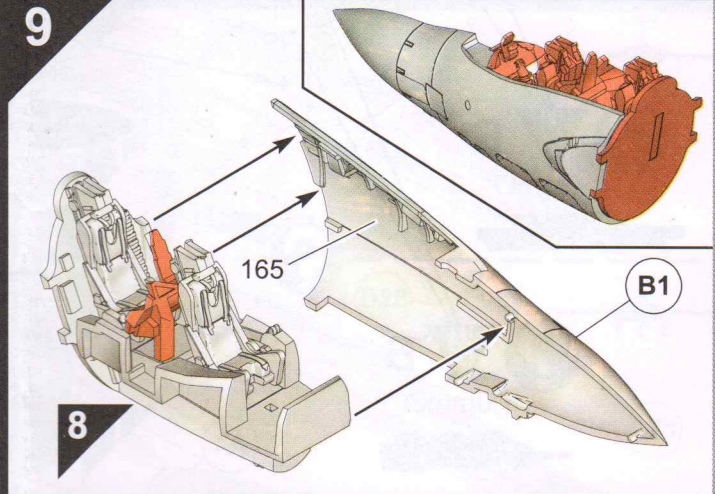
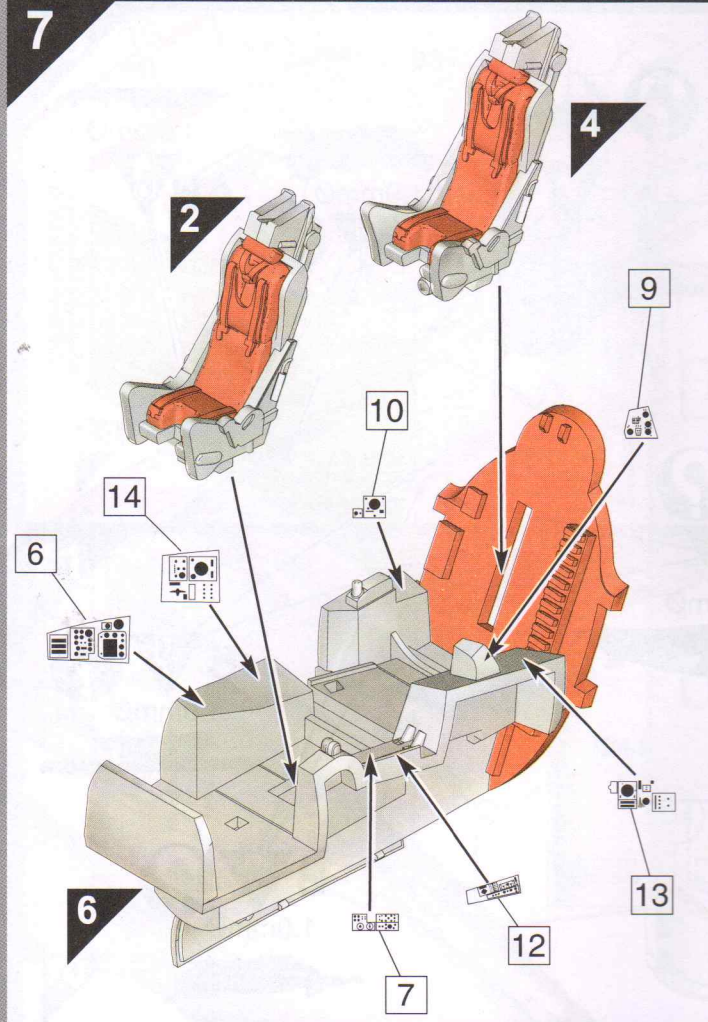
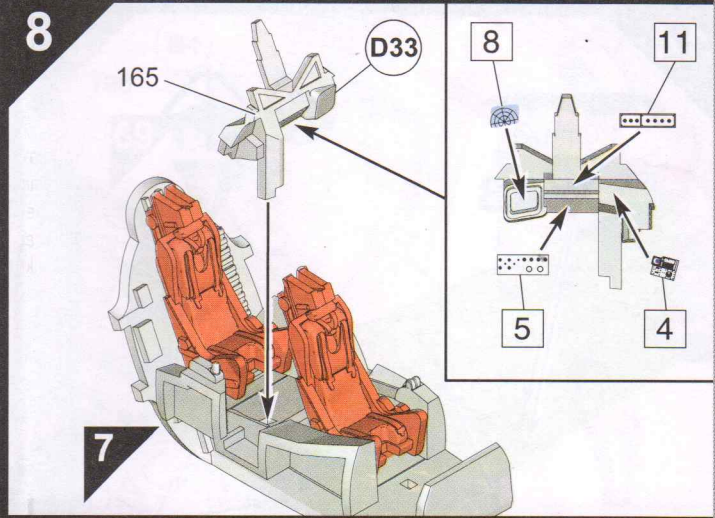
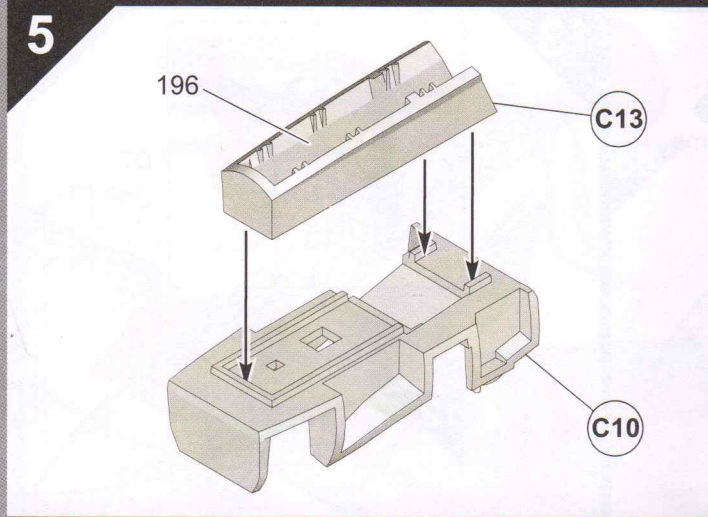
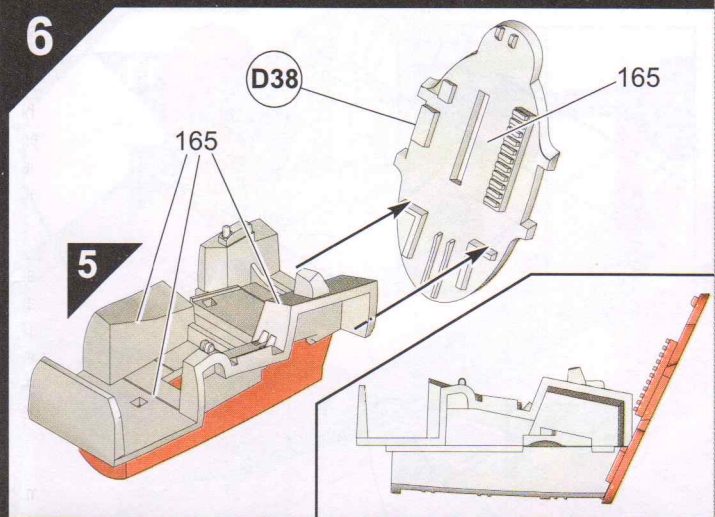
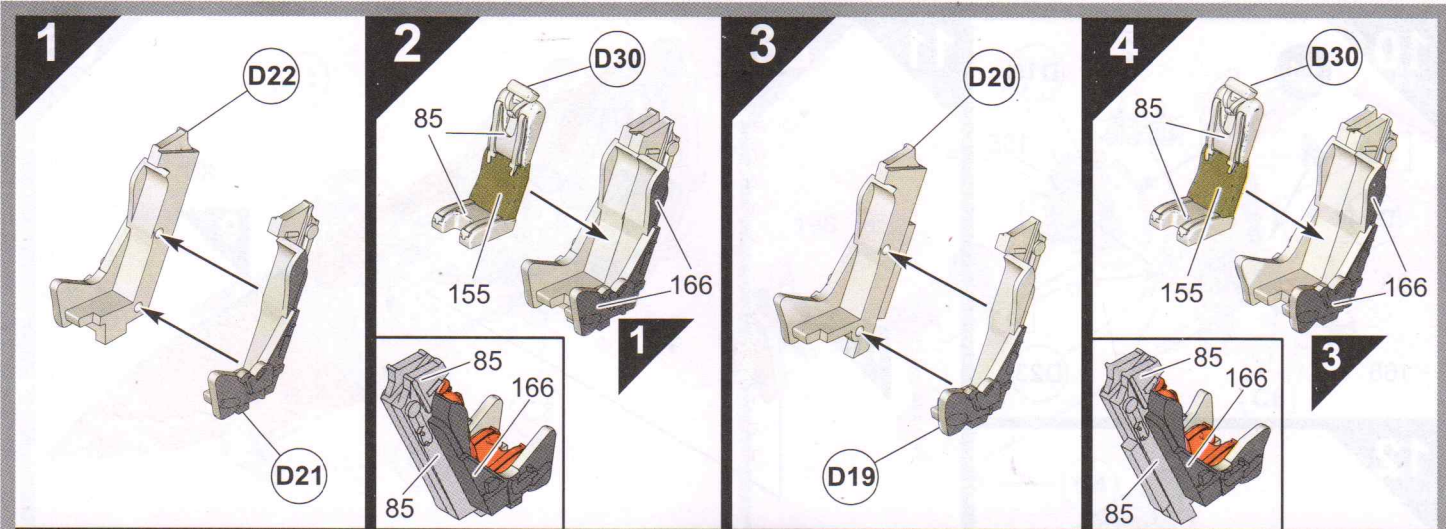

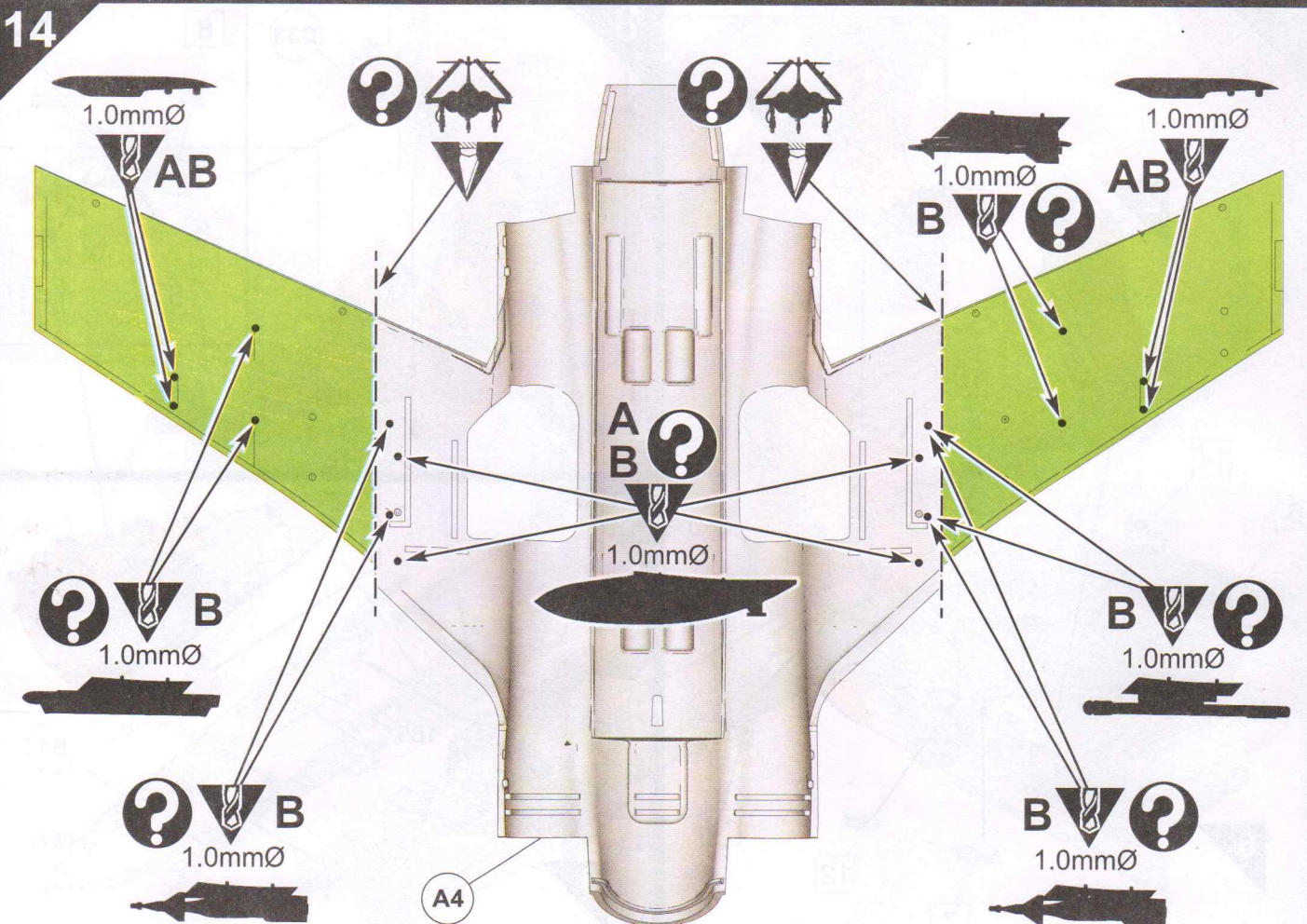
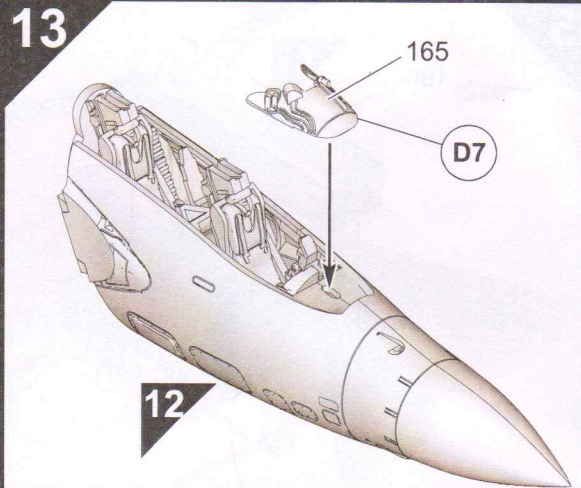
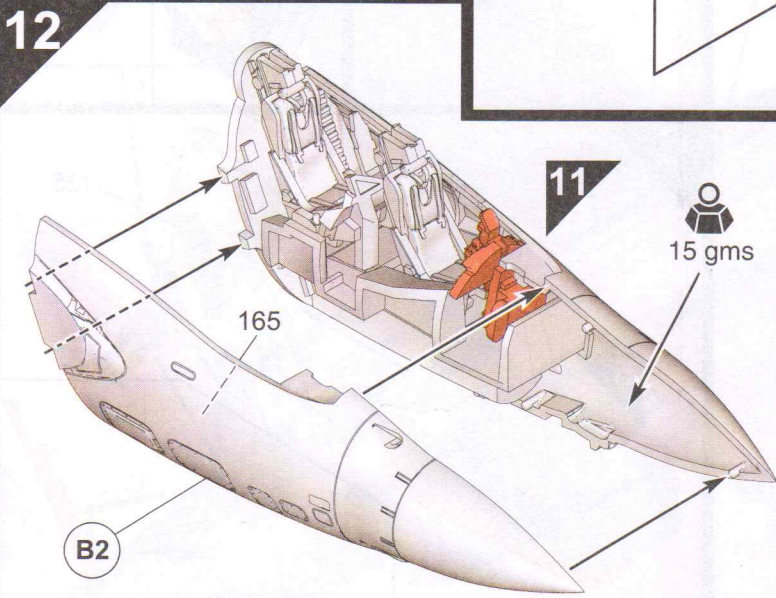
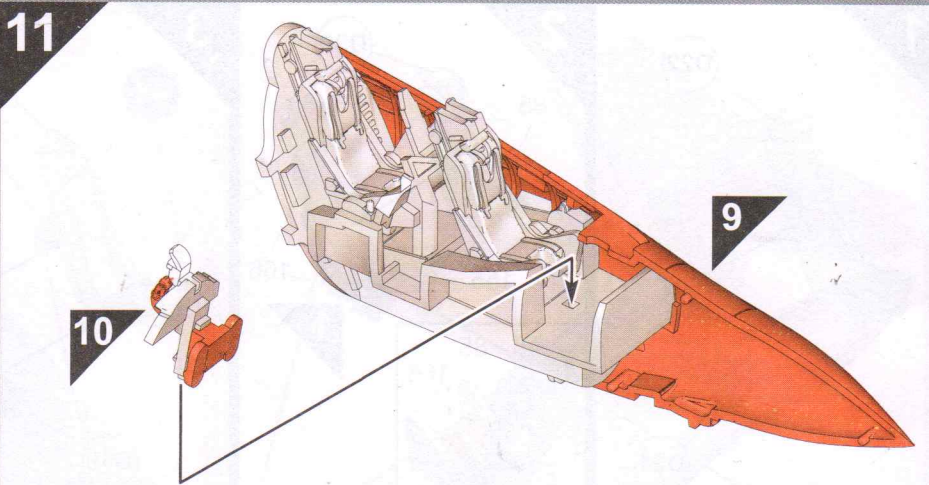
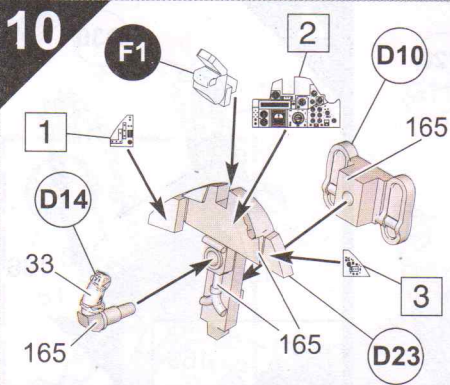

15

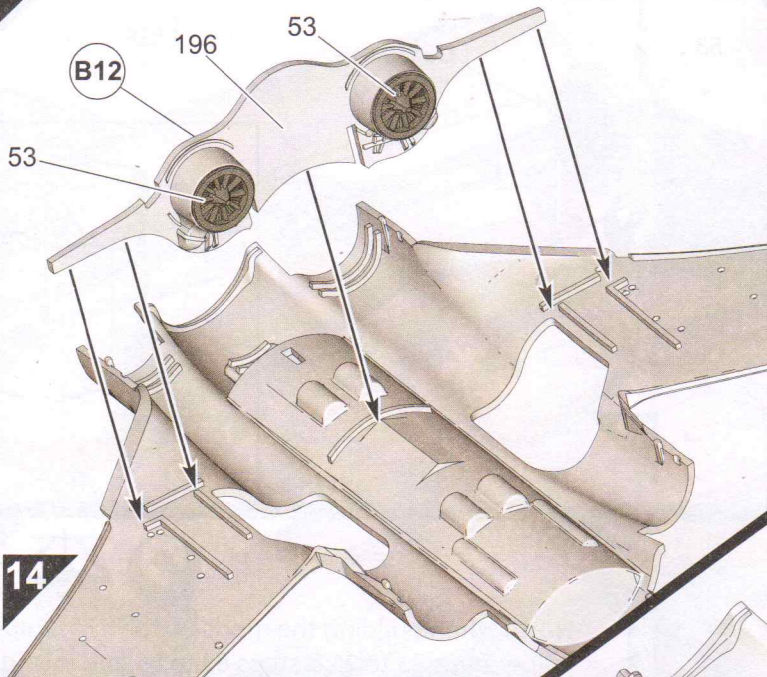

16

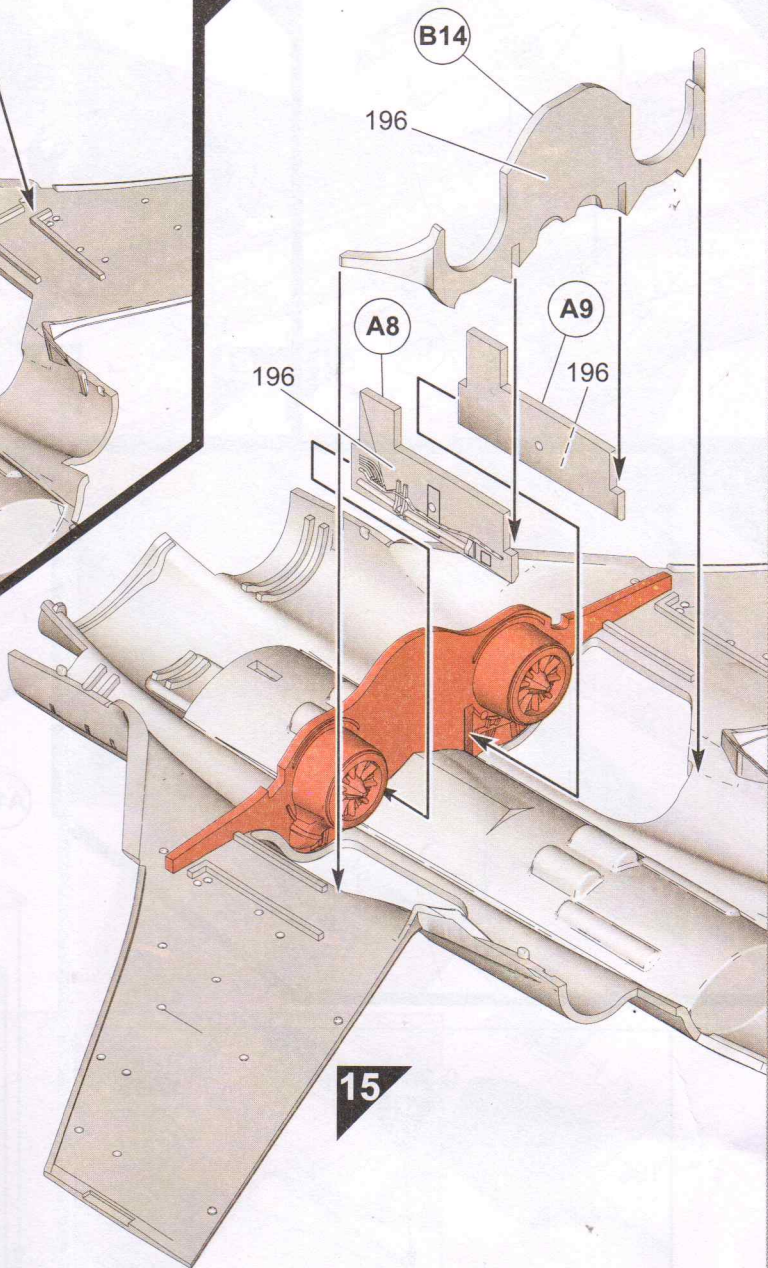

17

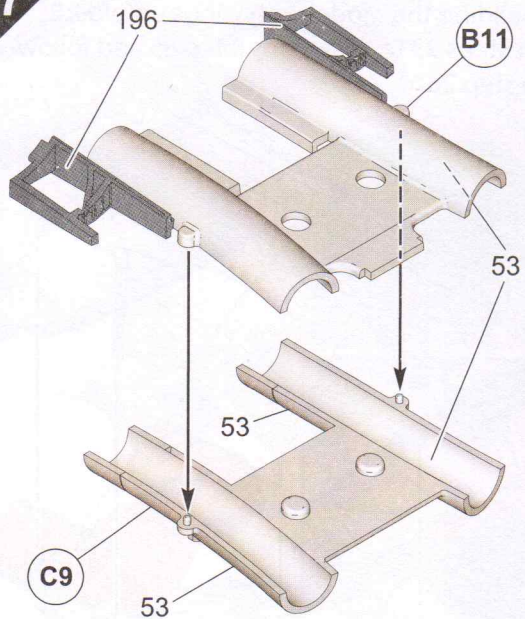

18

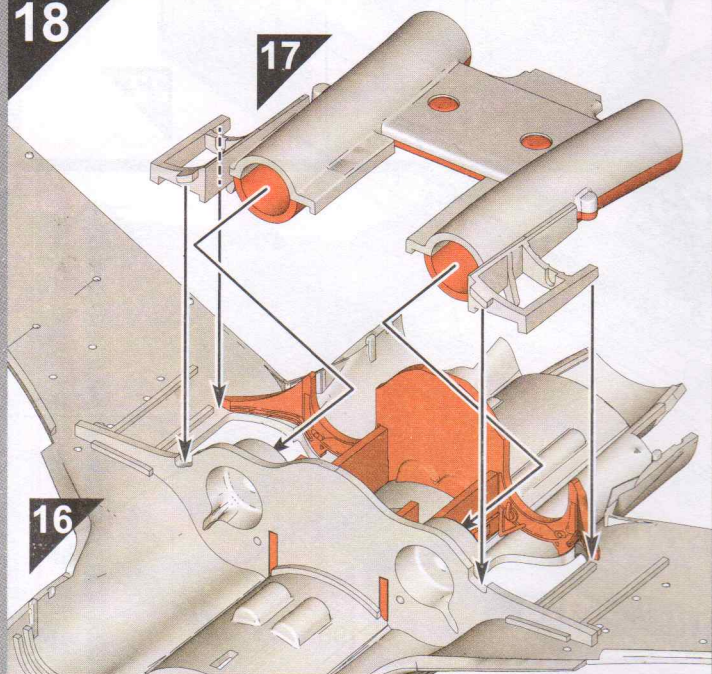

19

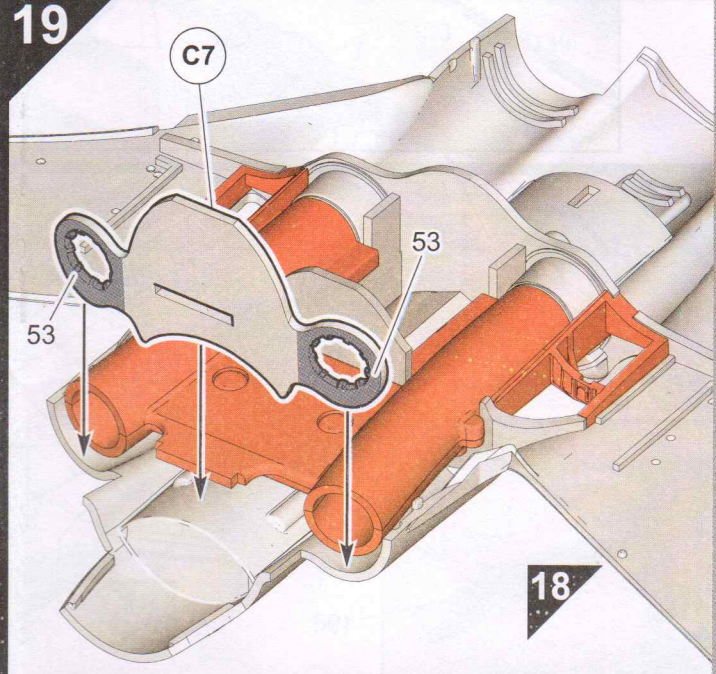

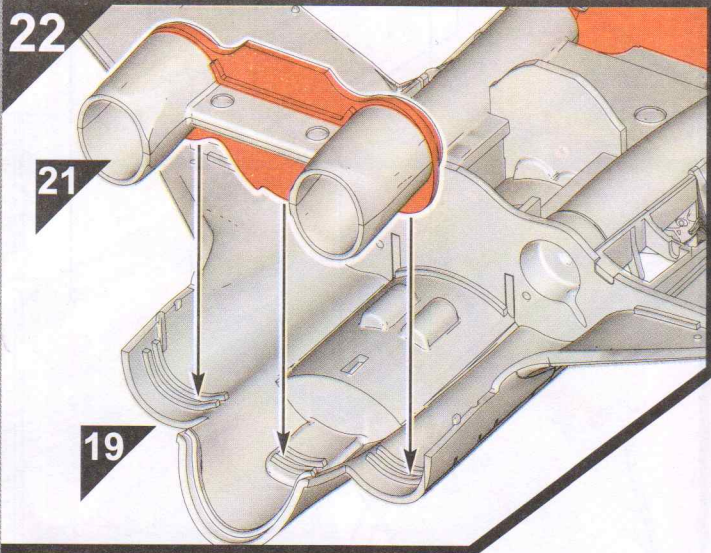
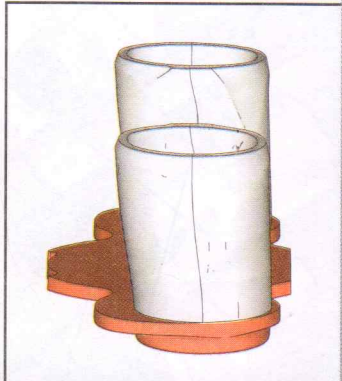
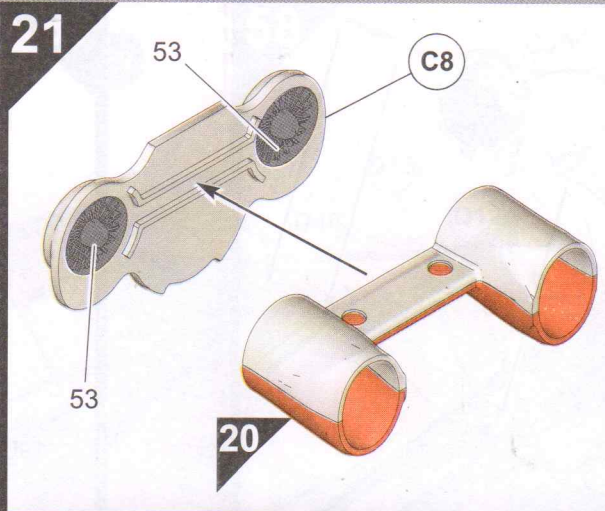
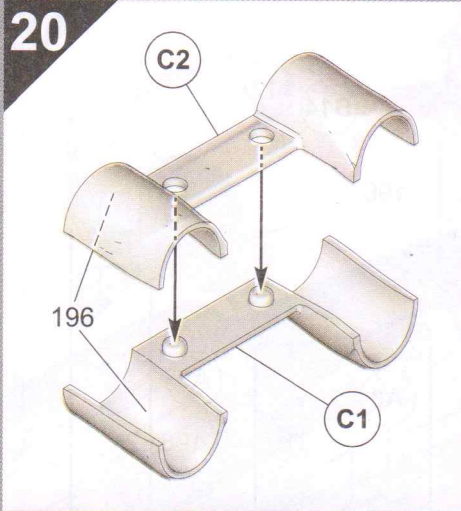

**23**

A15  
22

**Note:** When building the model with wings folded, follow steps 23 to 25 & steps 83 to 85 and miss out steps 26 to 30. When building the model with wings unfolded, miss out steps 23 to 25 & steps 83 to 85 and follow on from step 26.

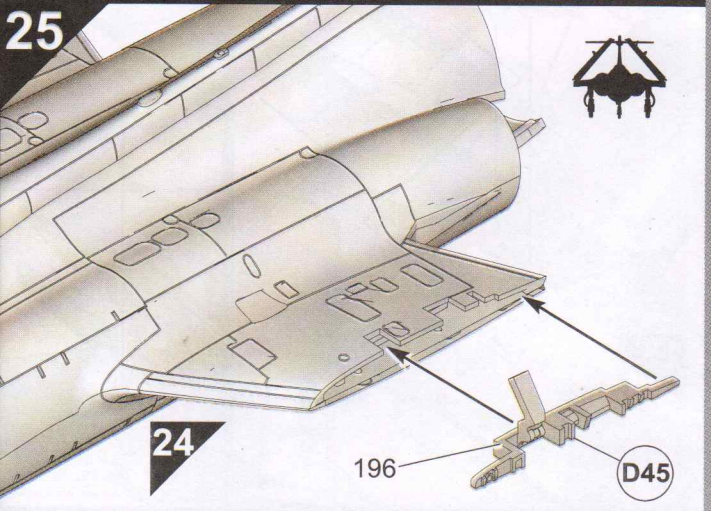
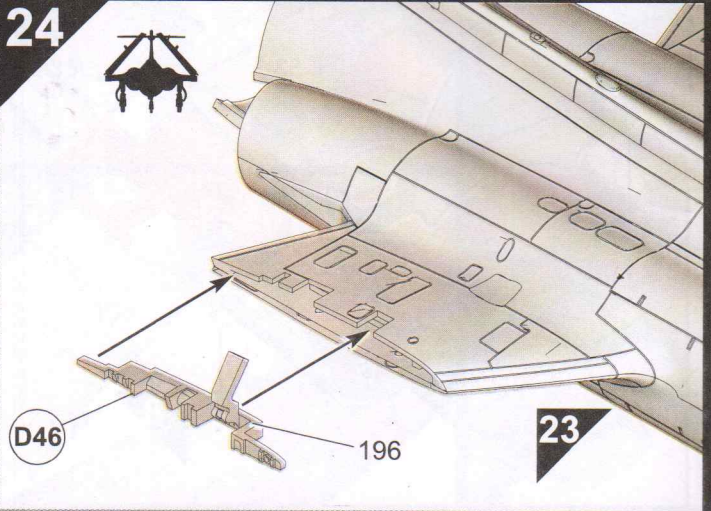
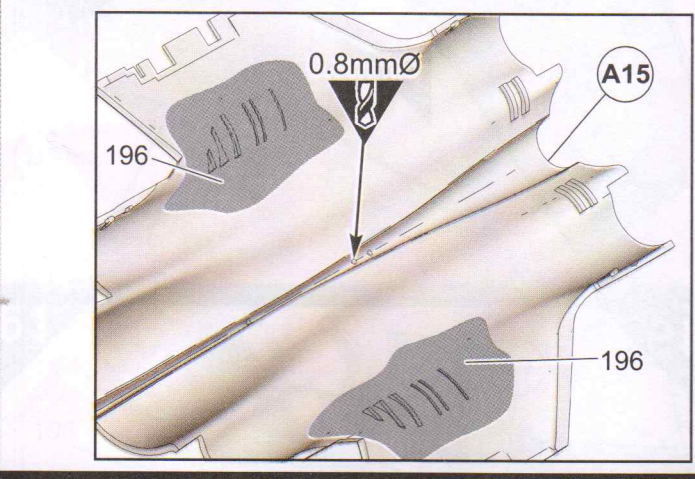

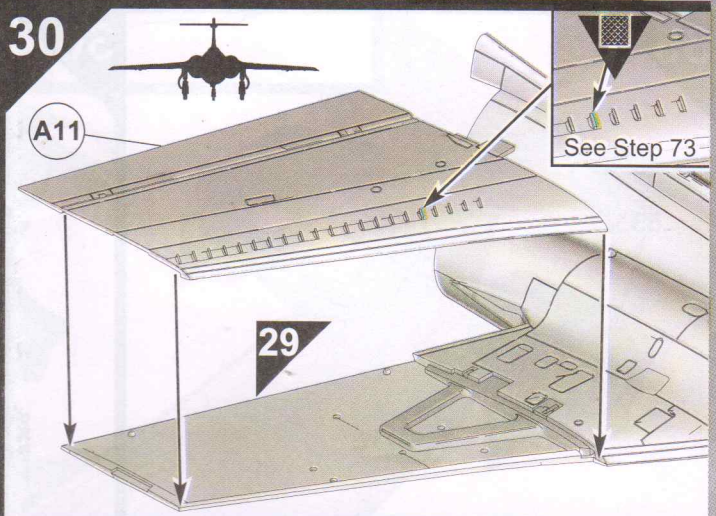
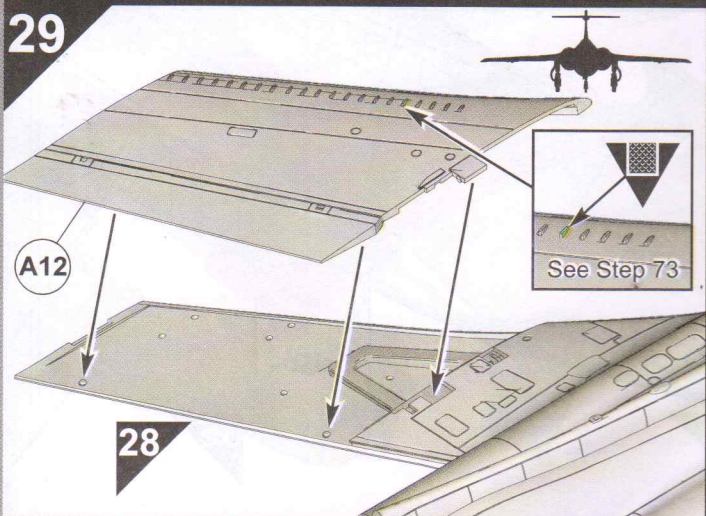
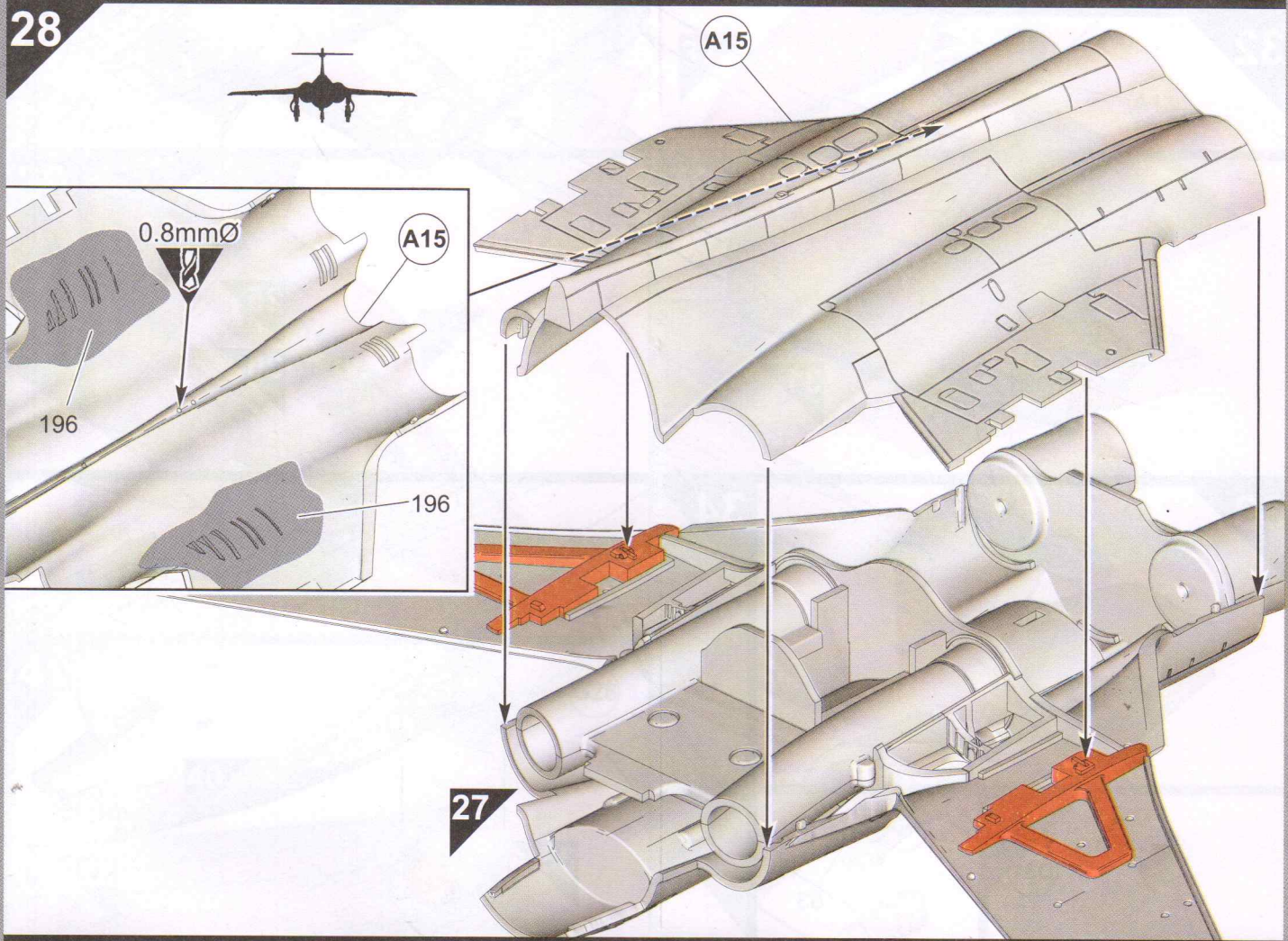
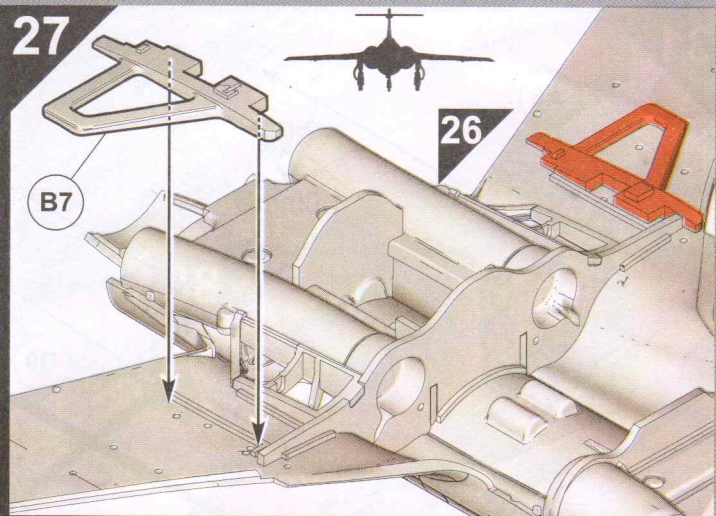
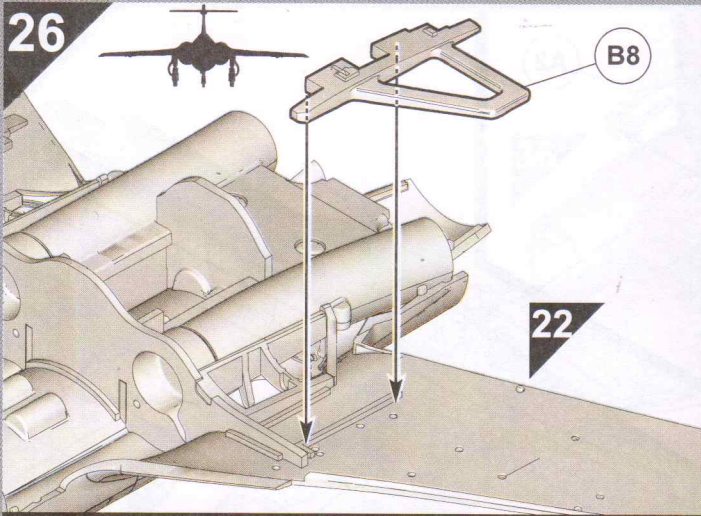

31

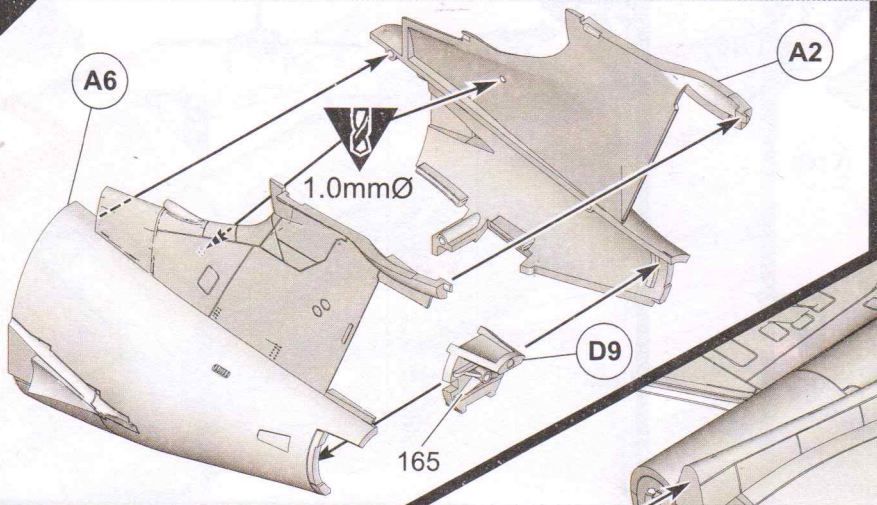

32

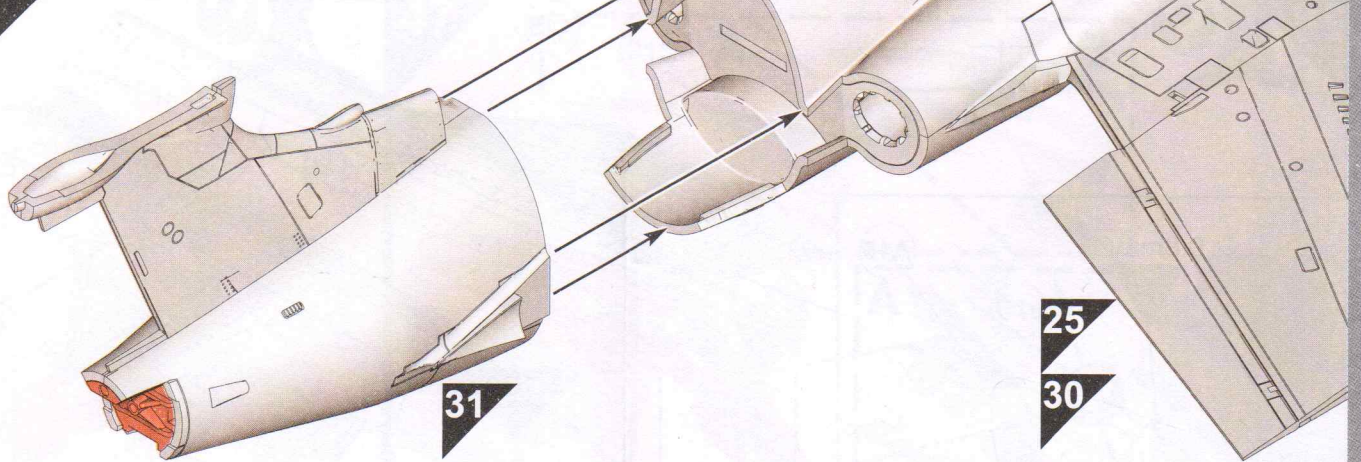

33

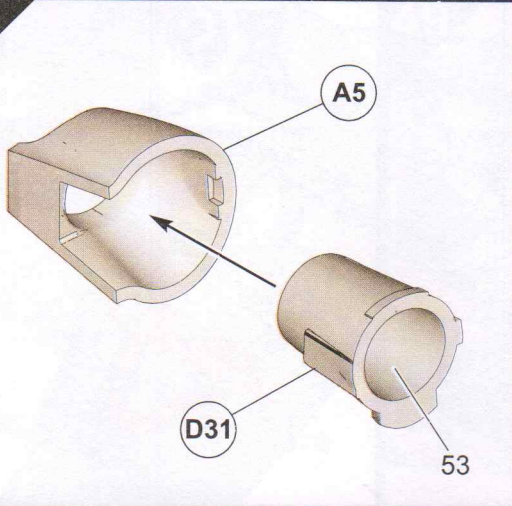

34

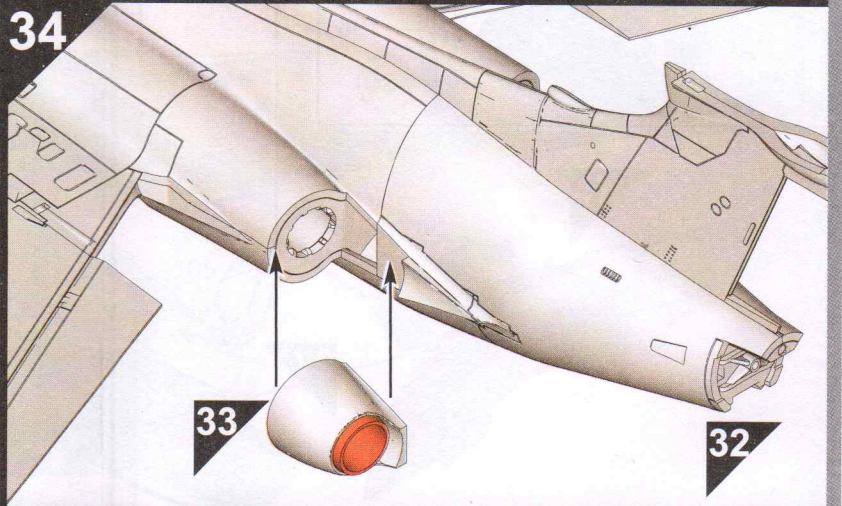

35

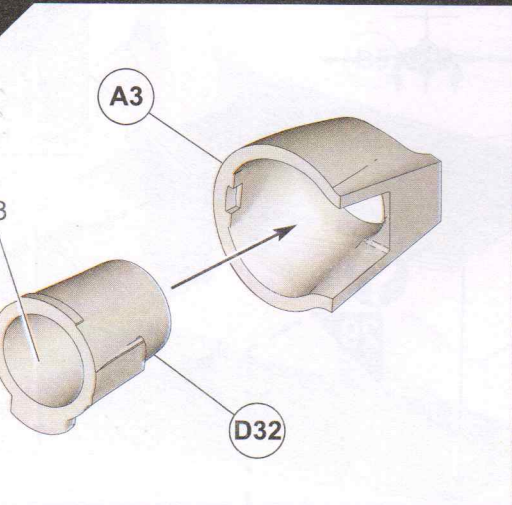

36

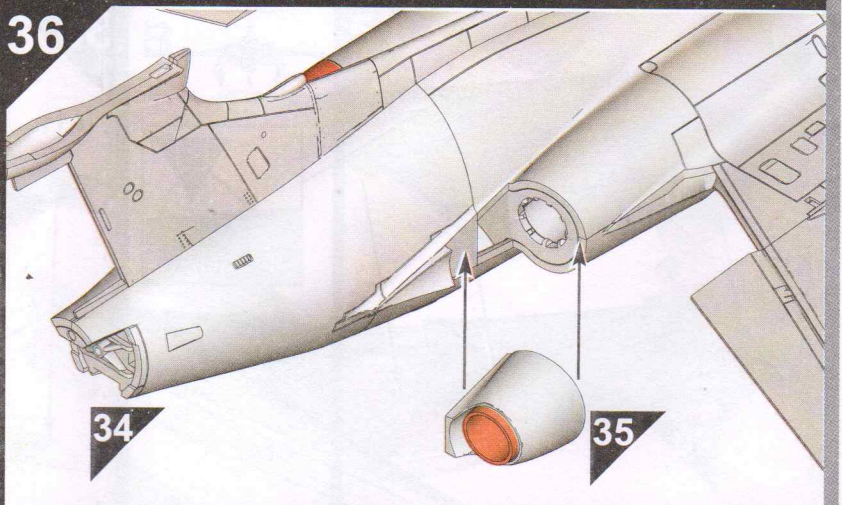



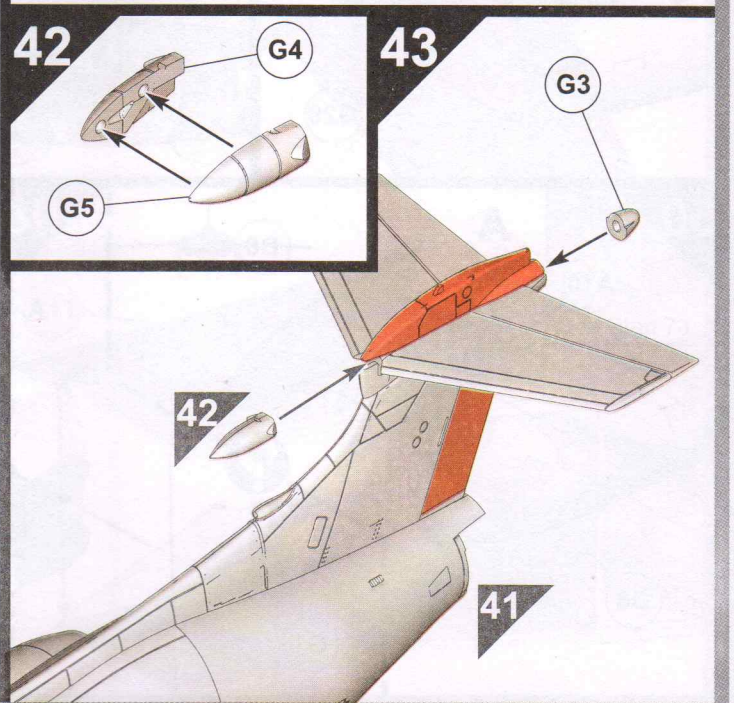
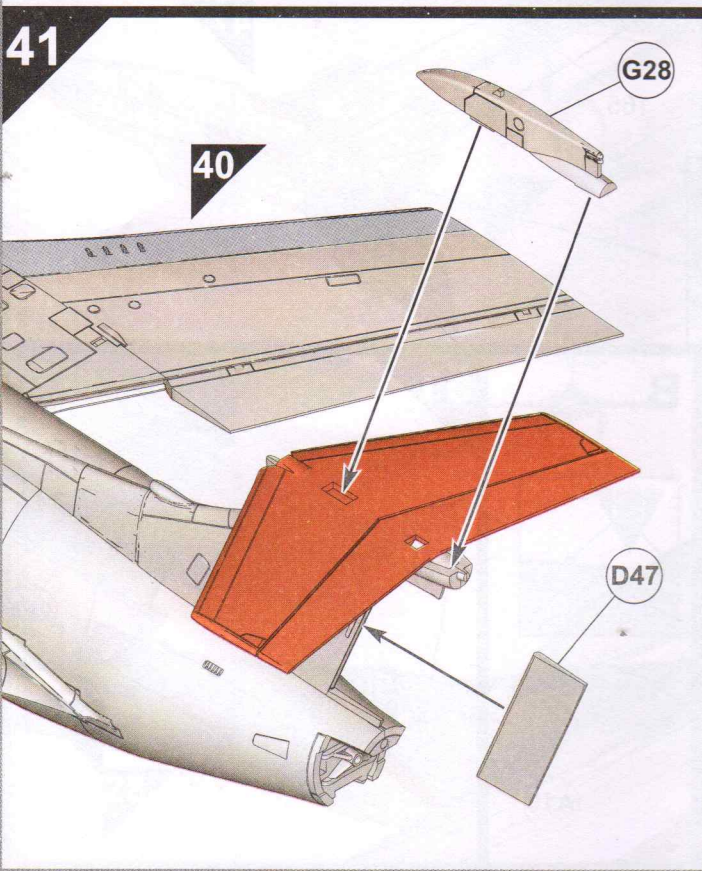
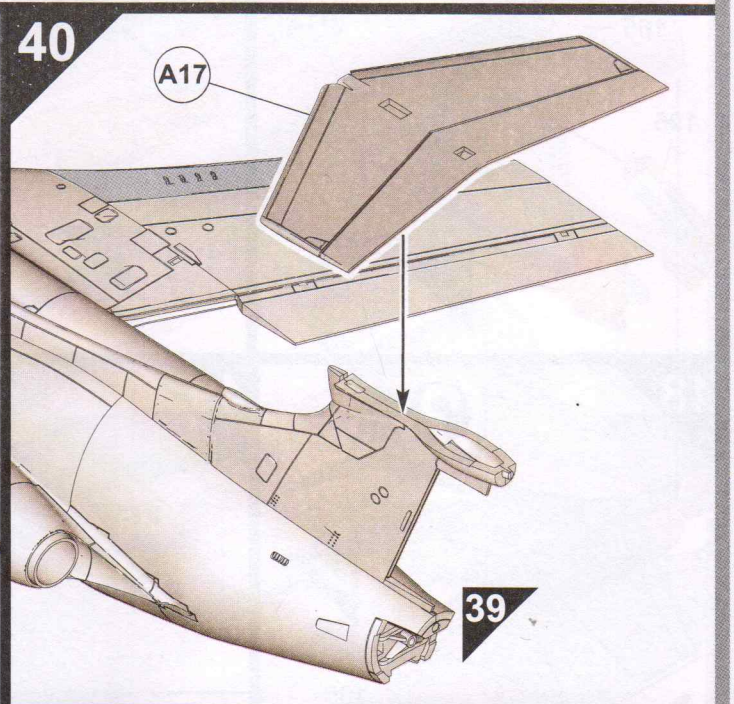
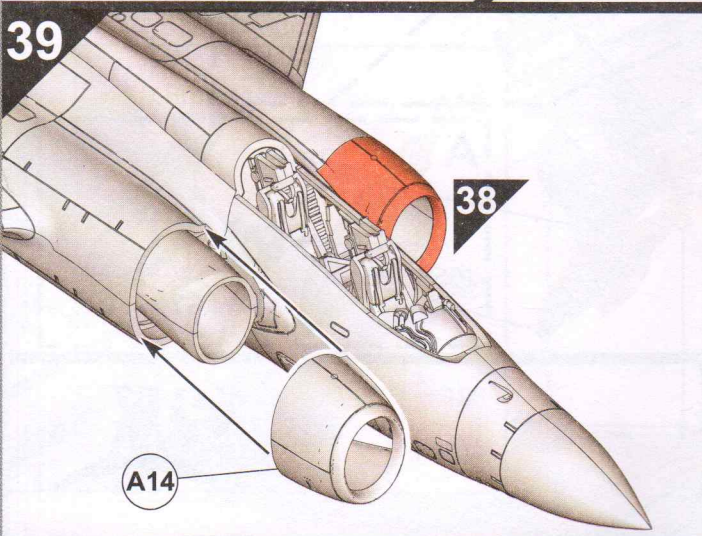
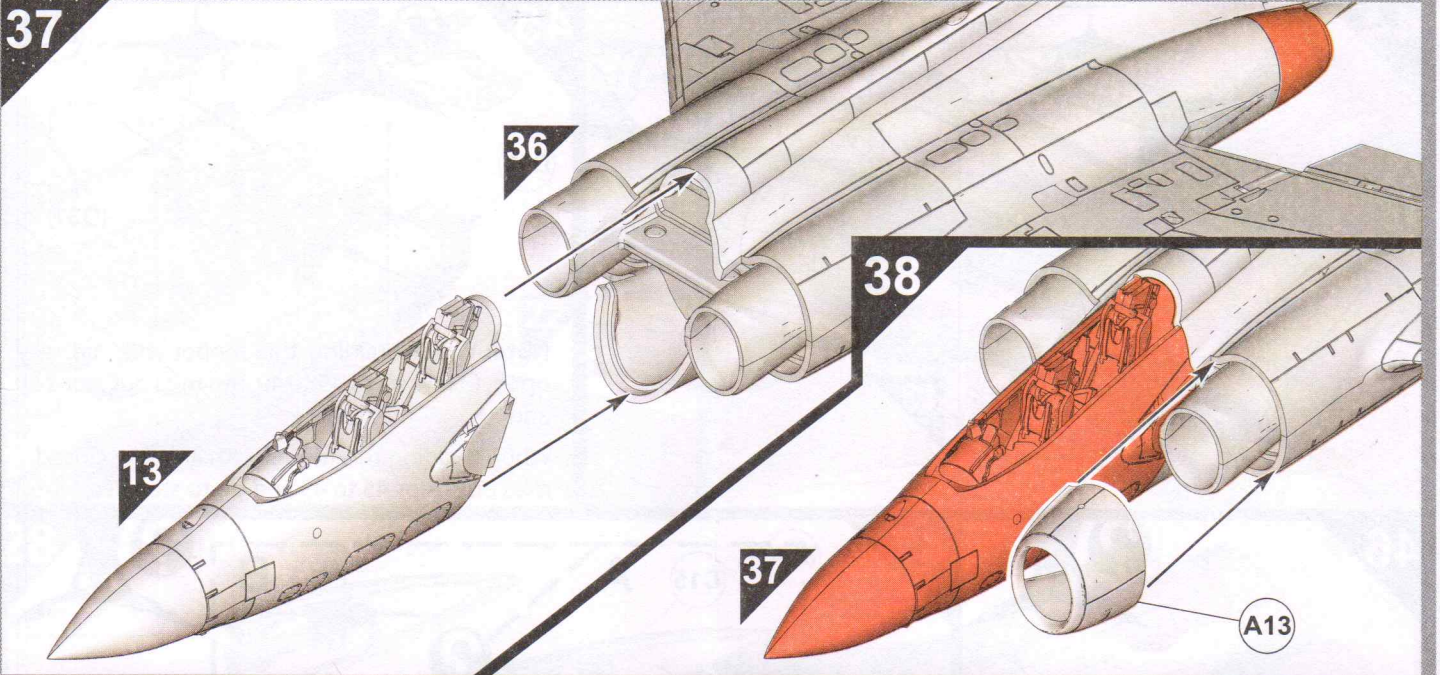

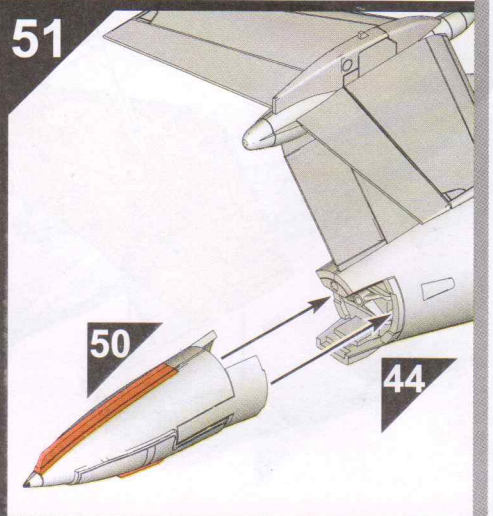
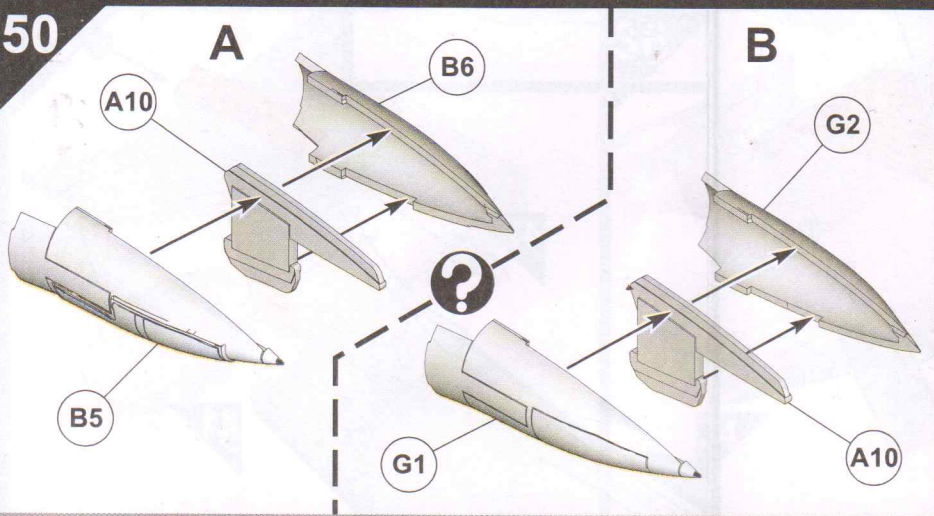
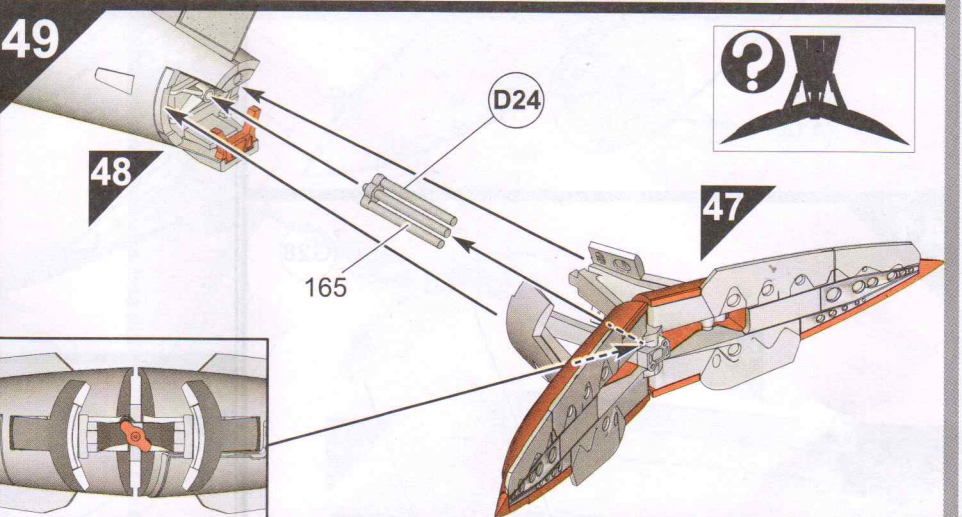
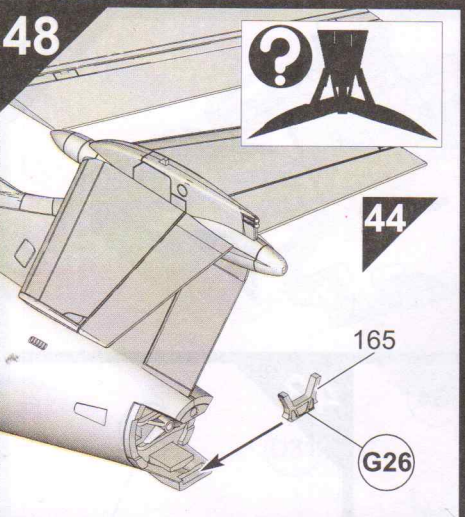
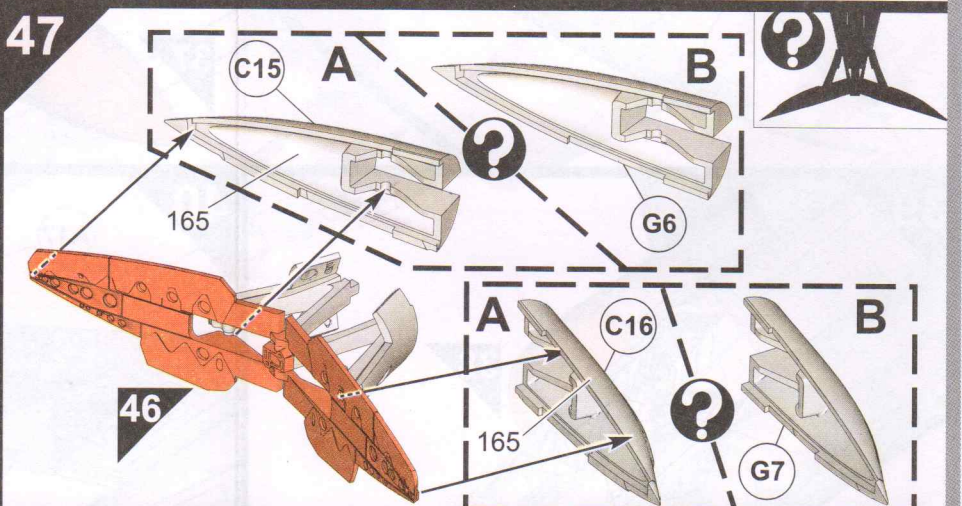
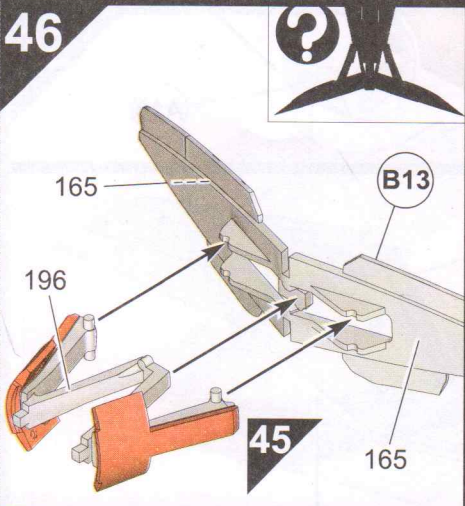
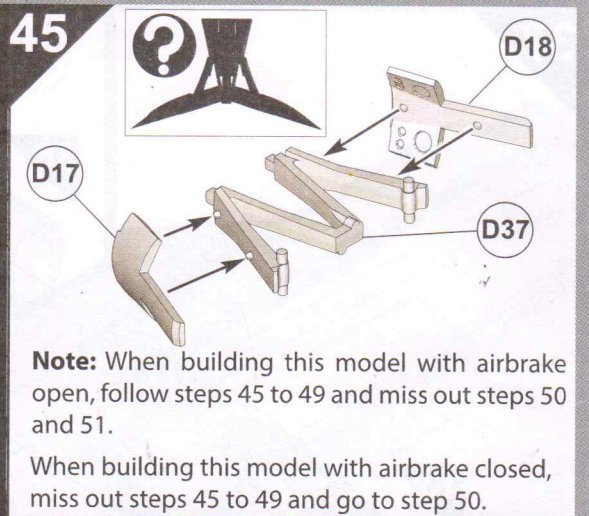
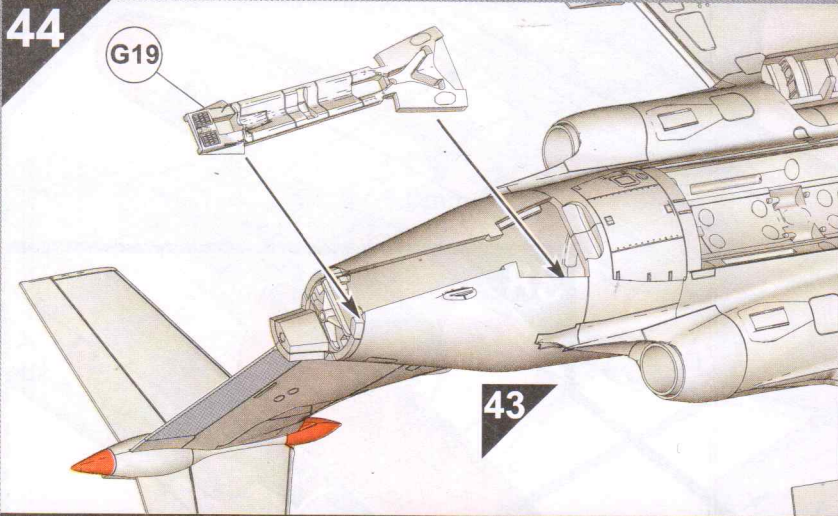

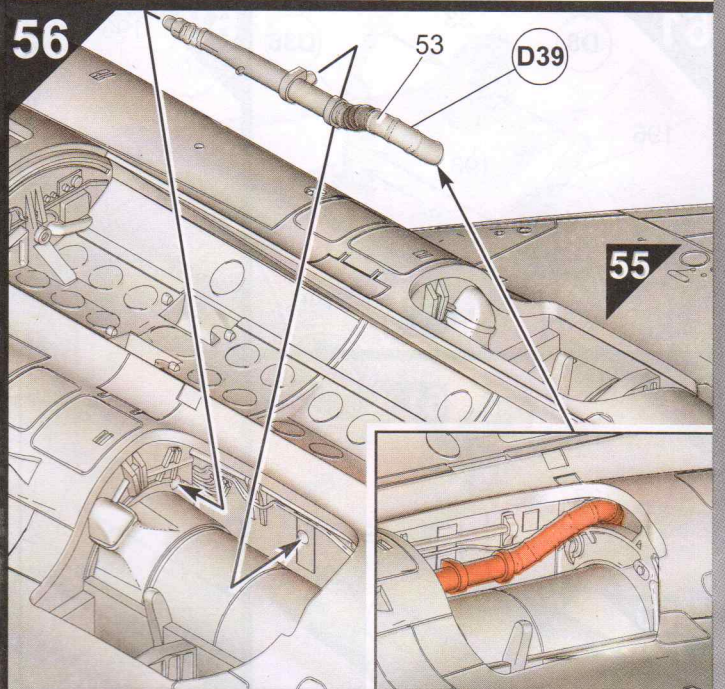
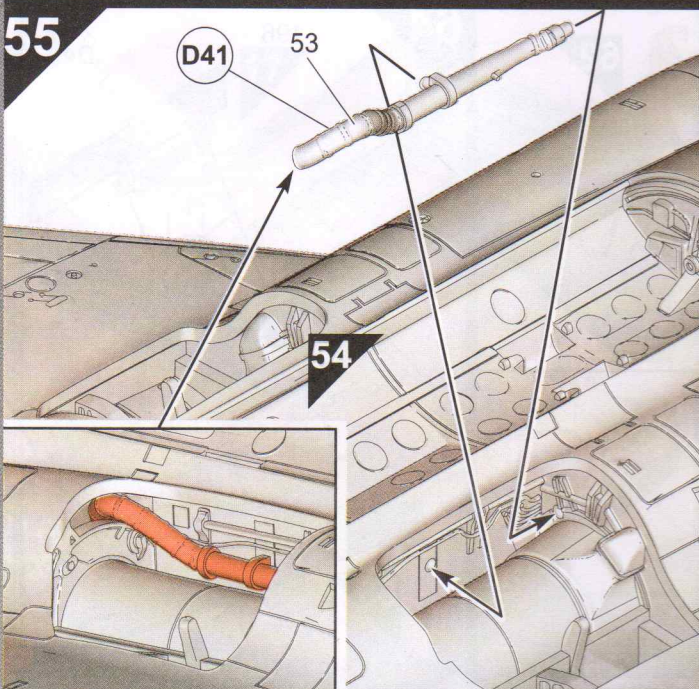
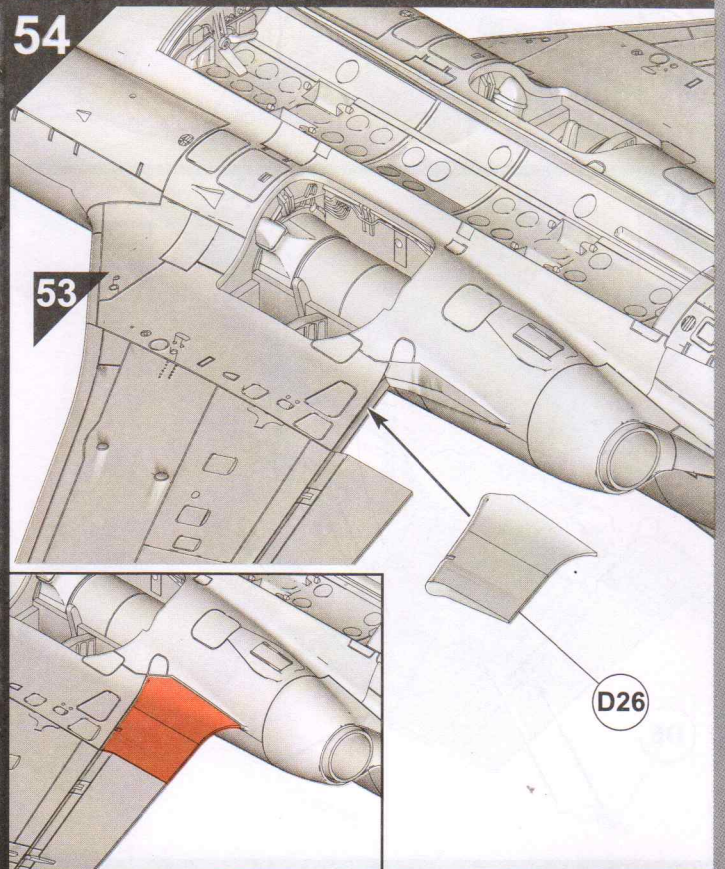
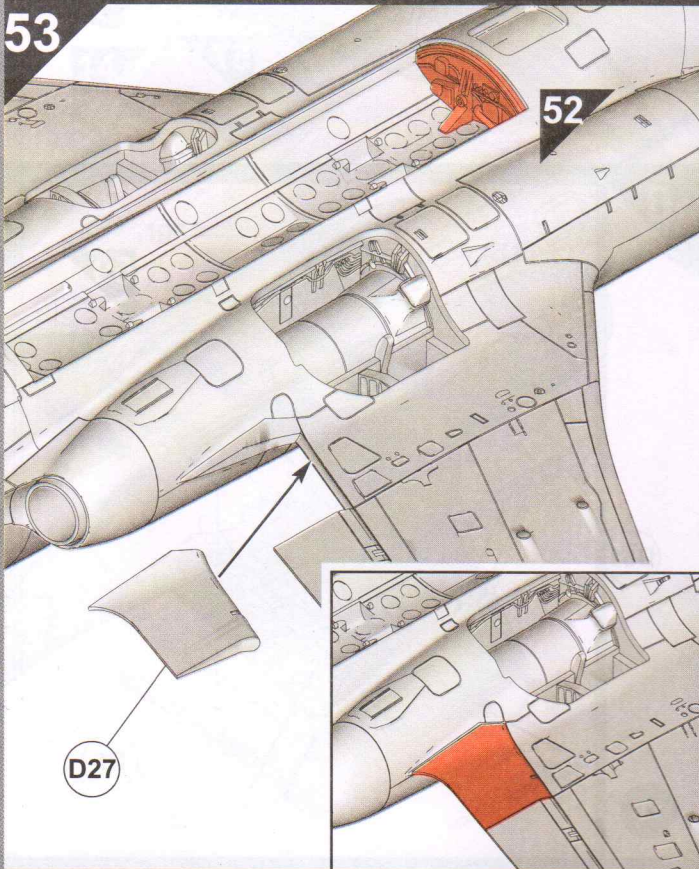
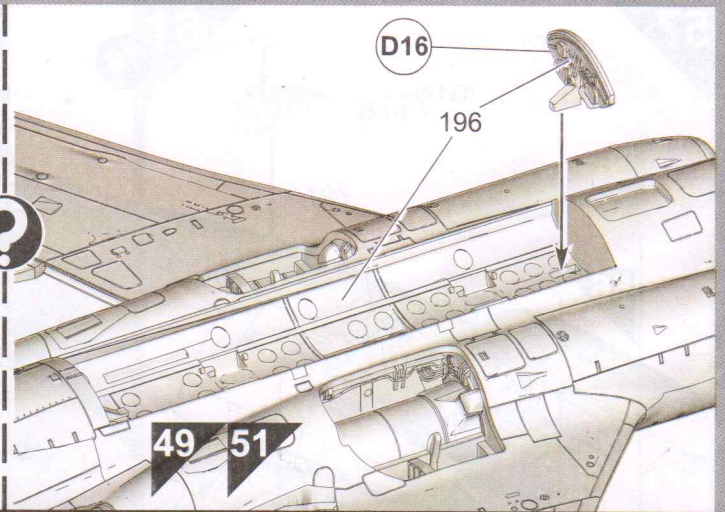
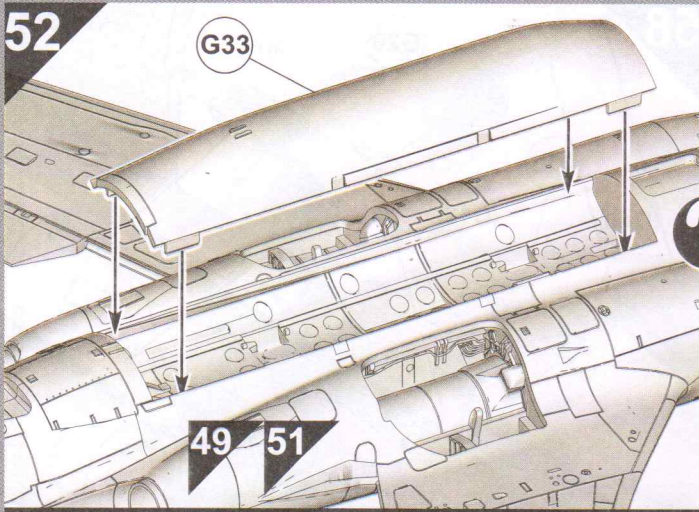

57

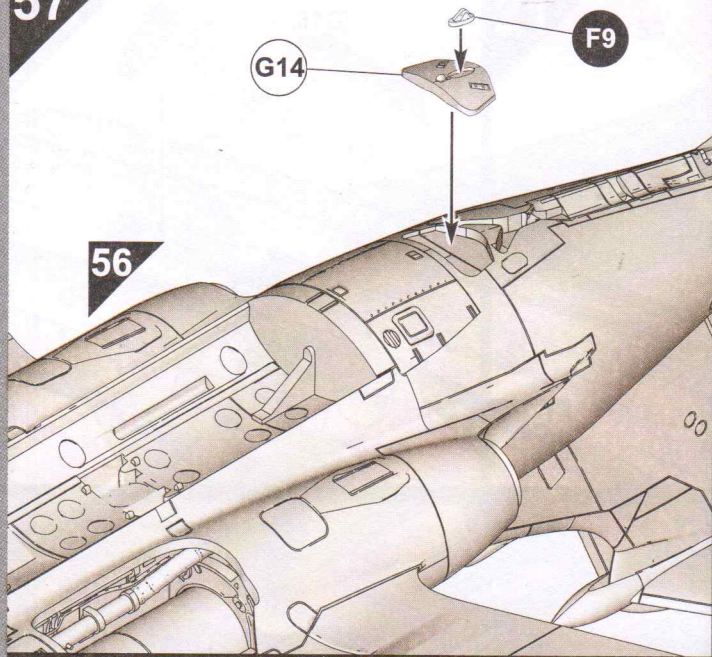

58

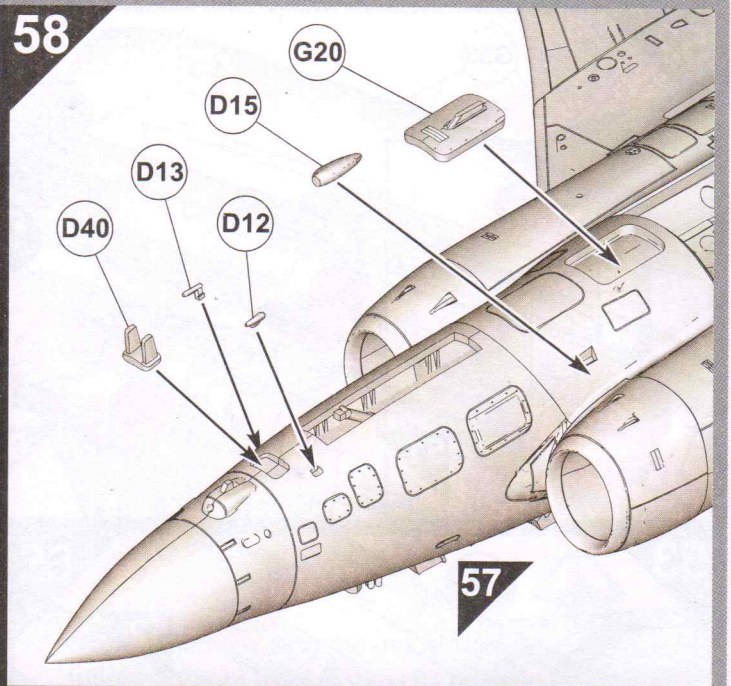

59

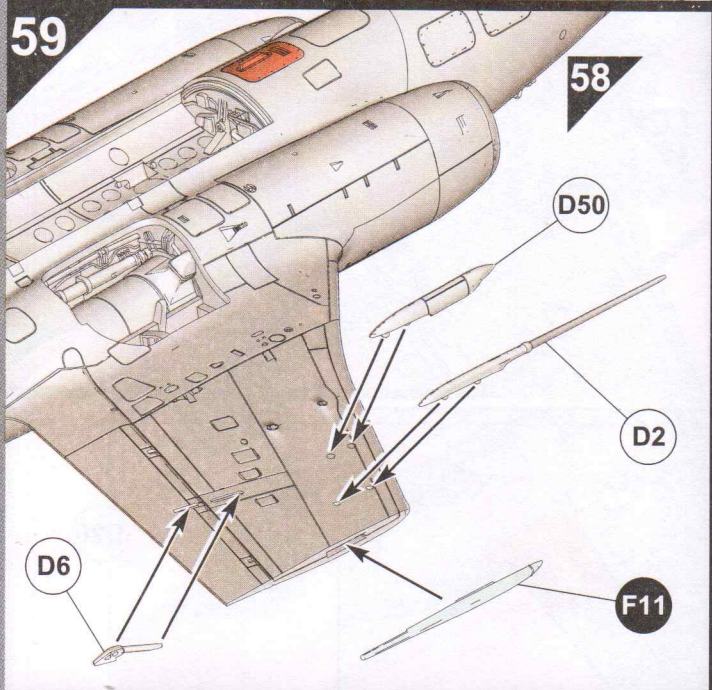

60

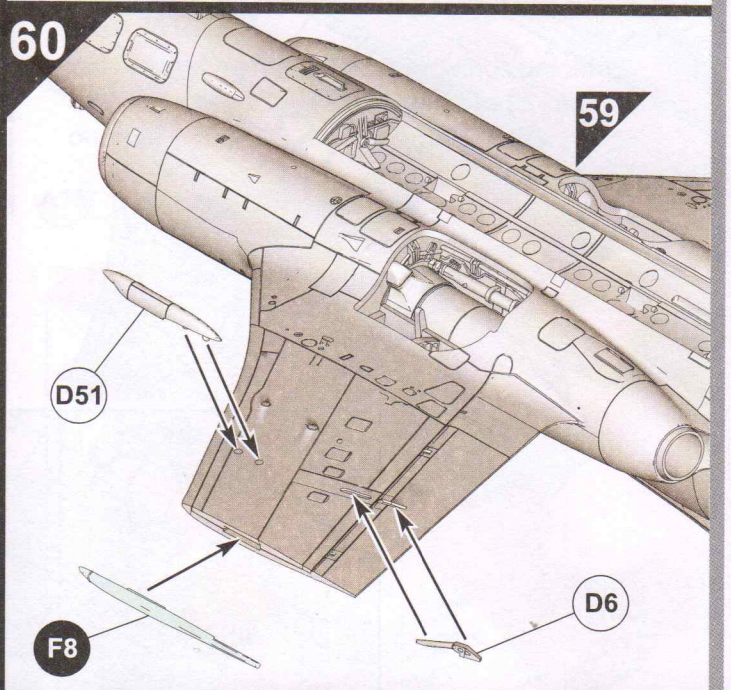

61

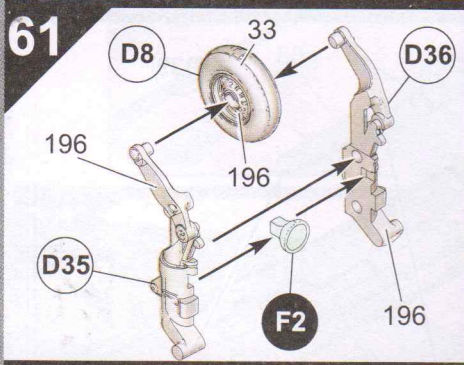

63

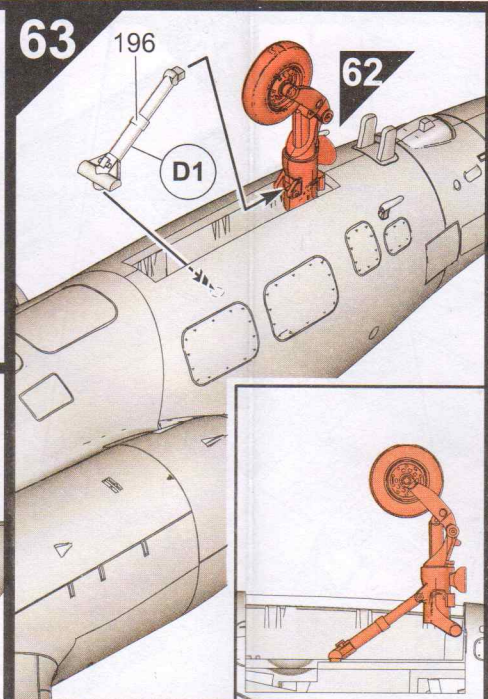

64



62

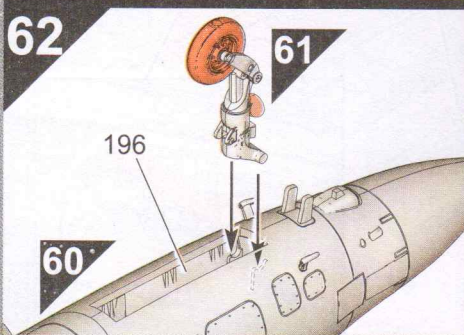

65

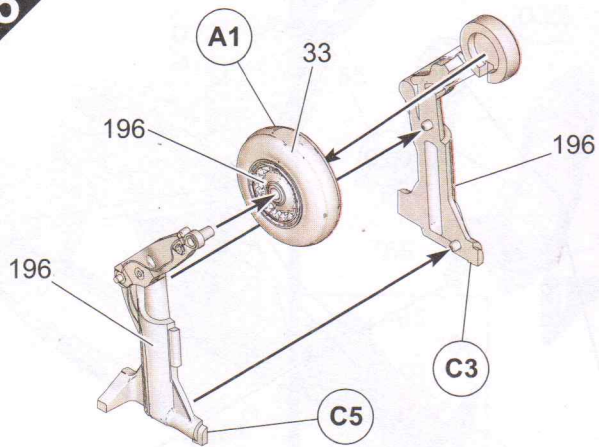

66

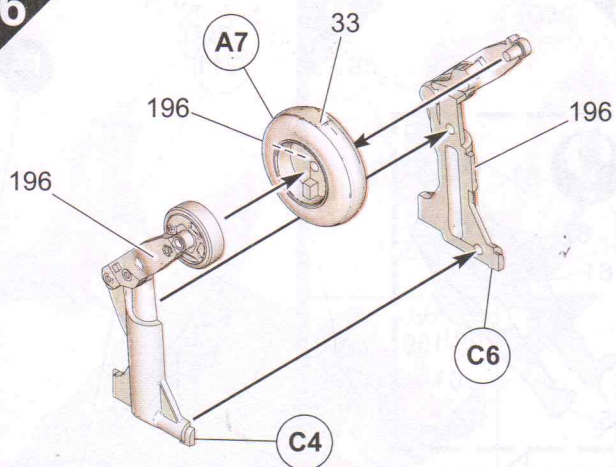

67

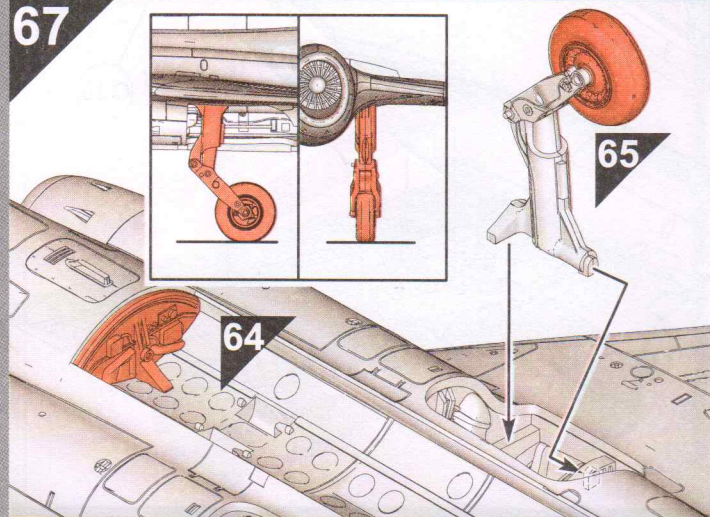

68

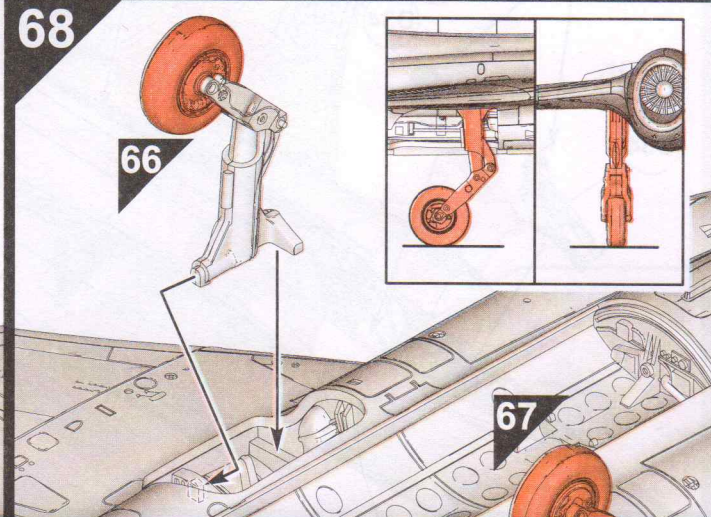

69

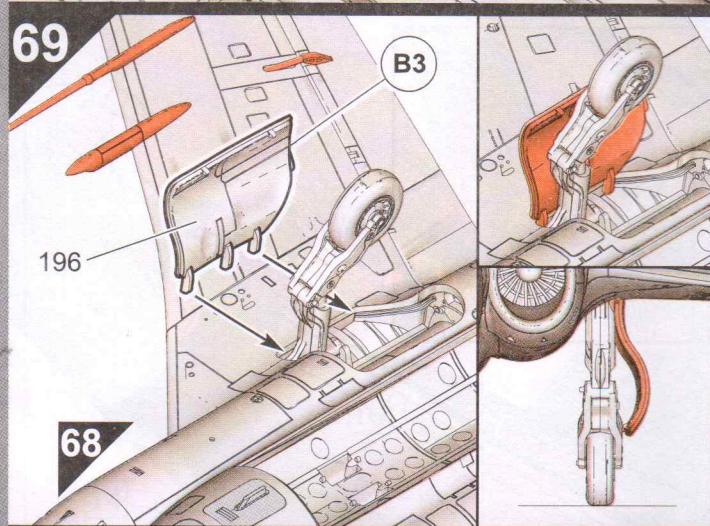

70

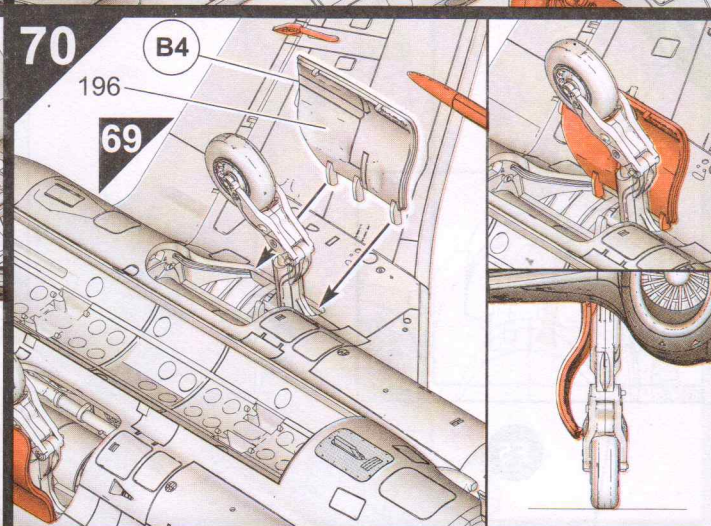

71

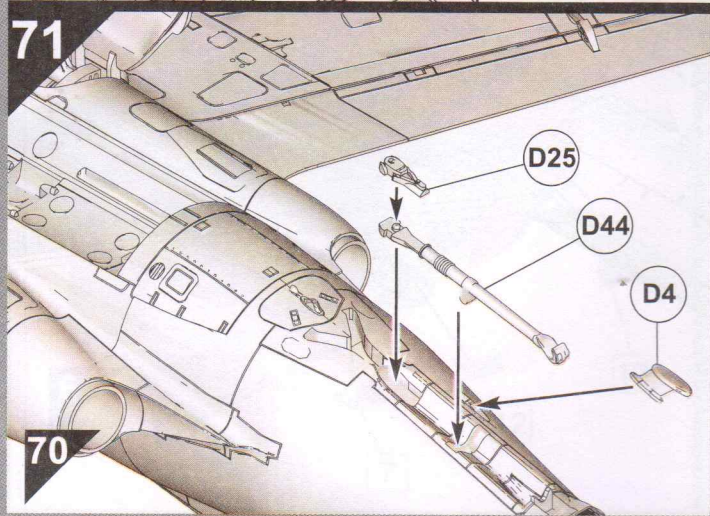

72

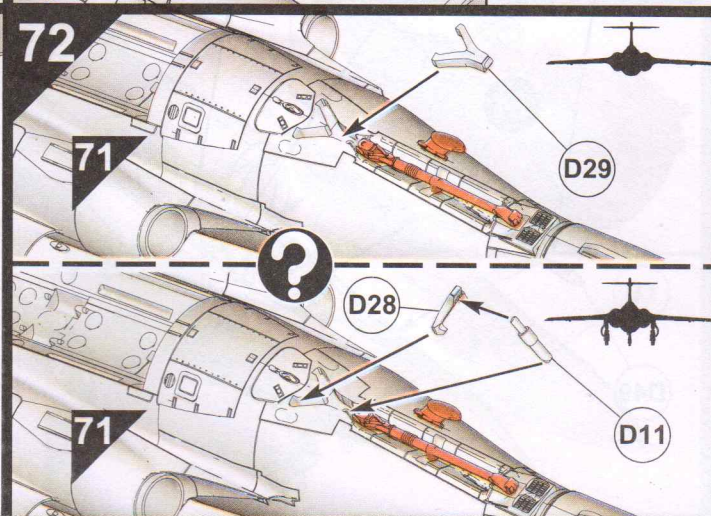

73

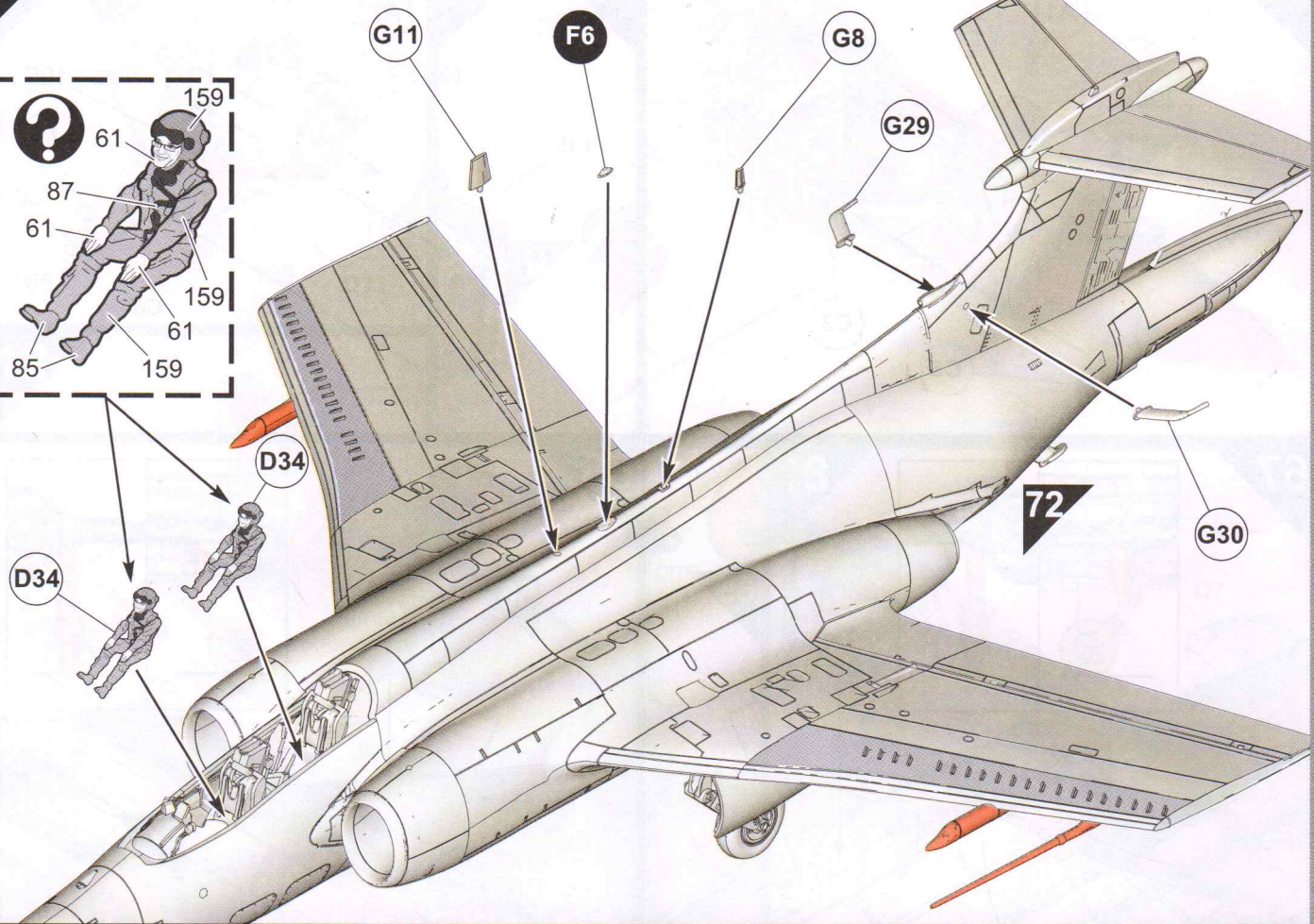
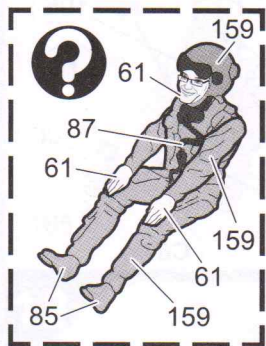

74

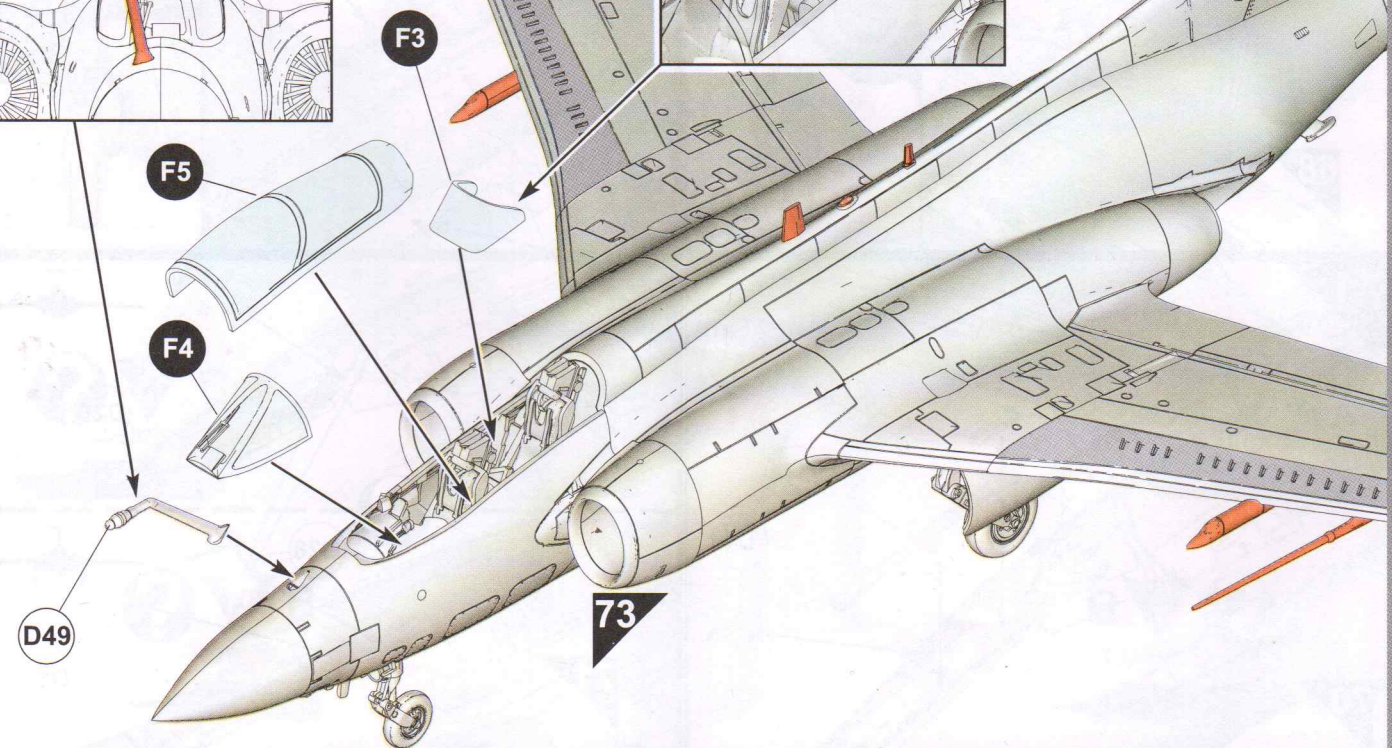
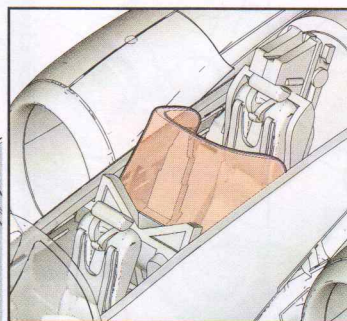
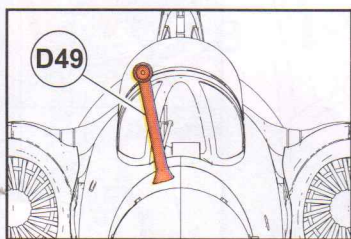

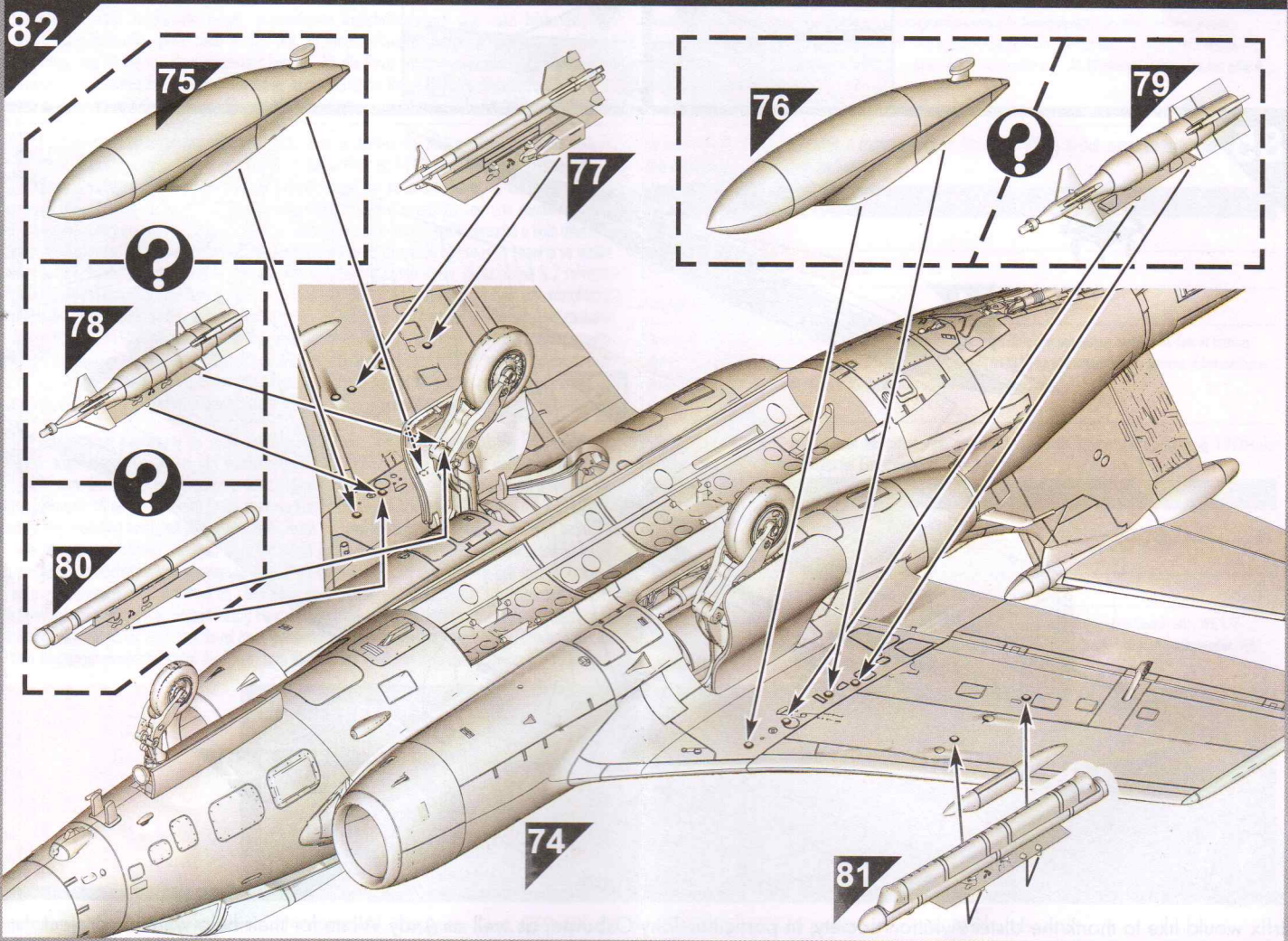
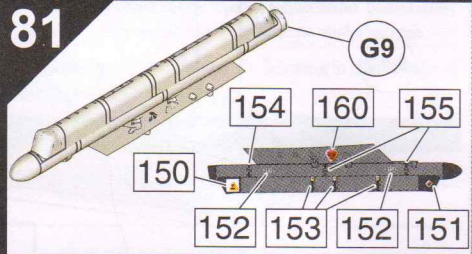
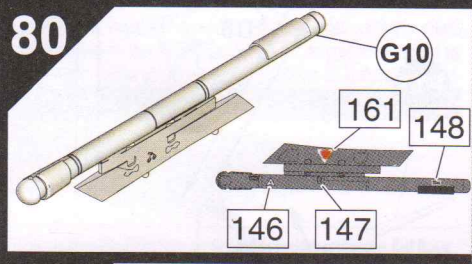
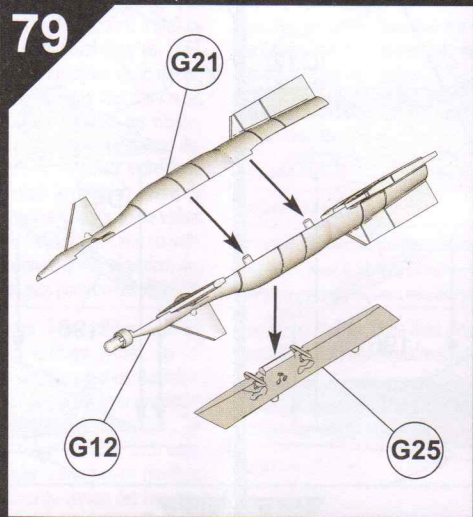
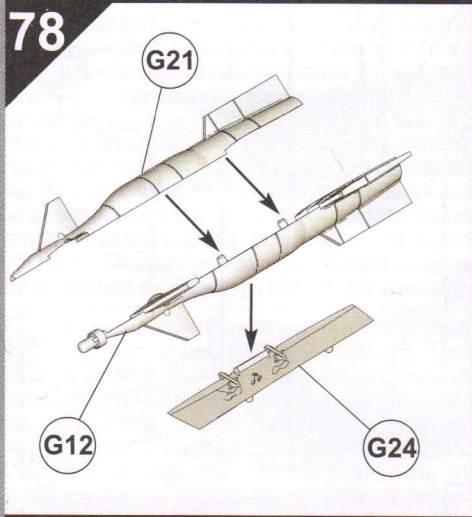
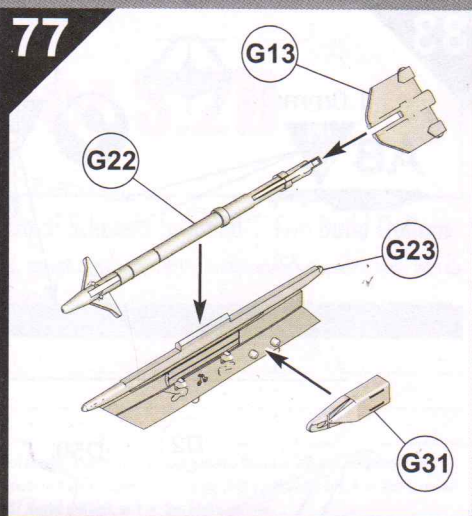
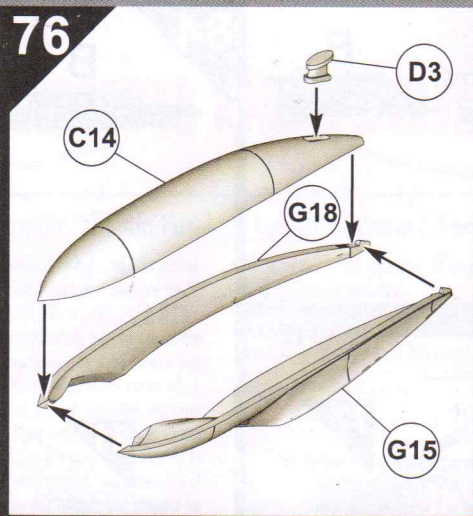
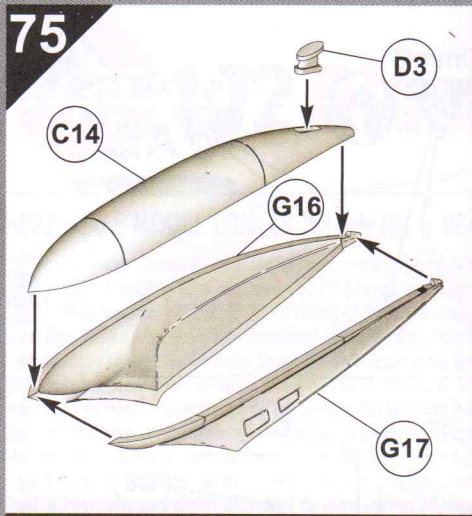

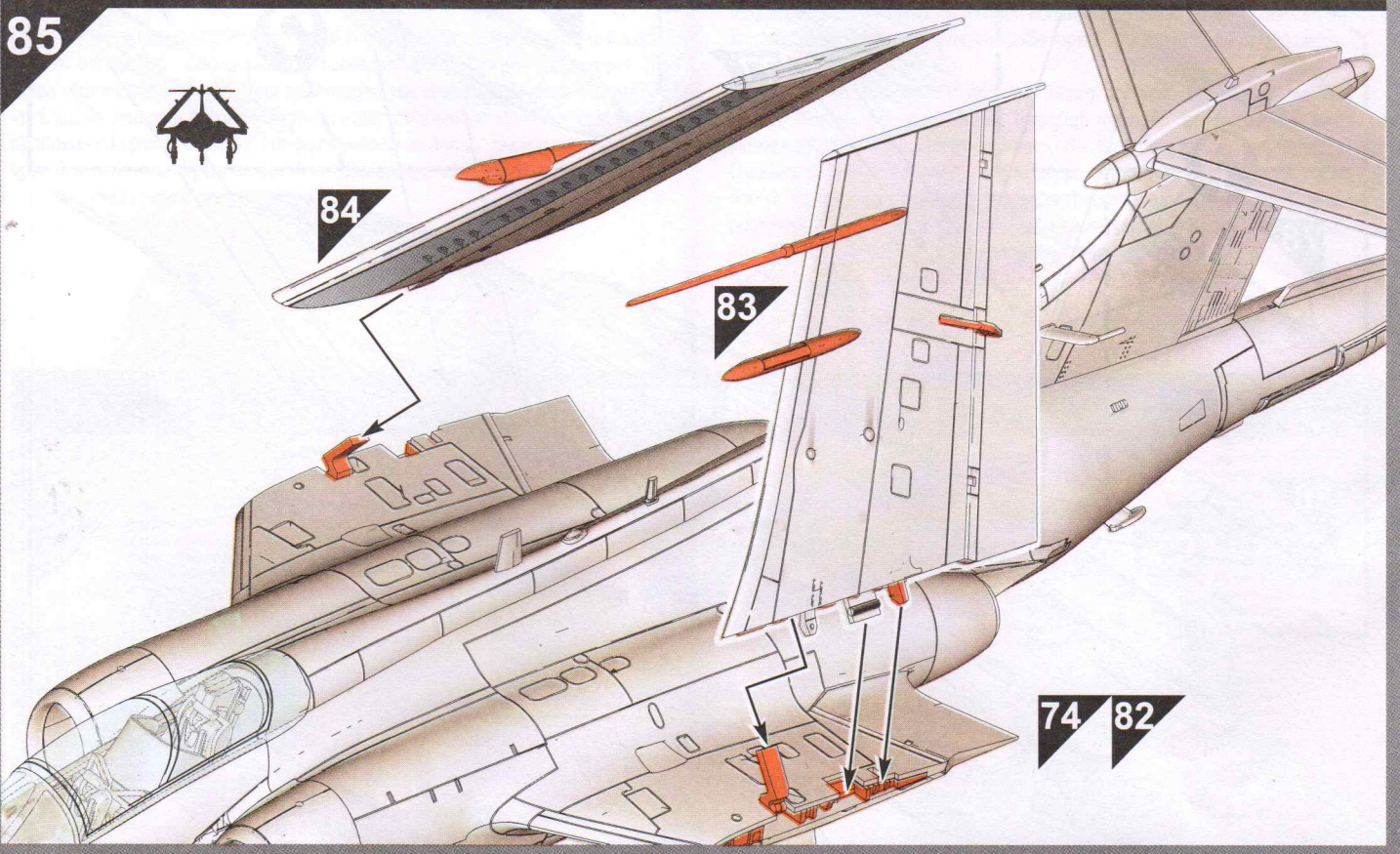
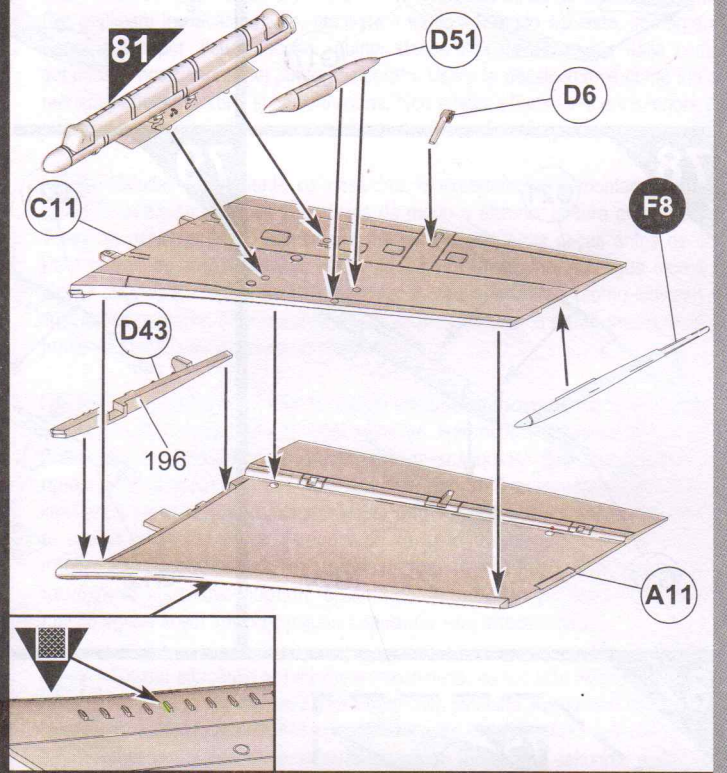
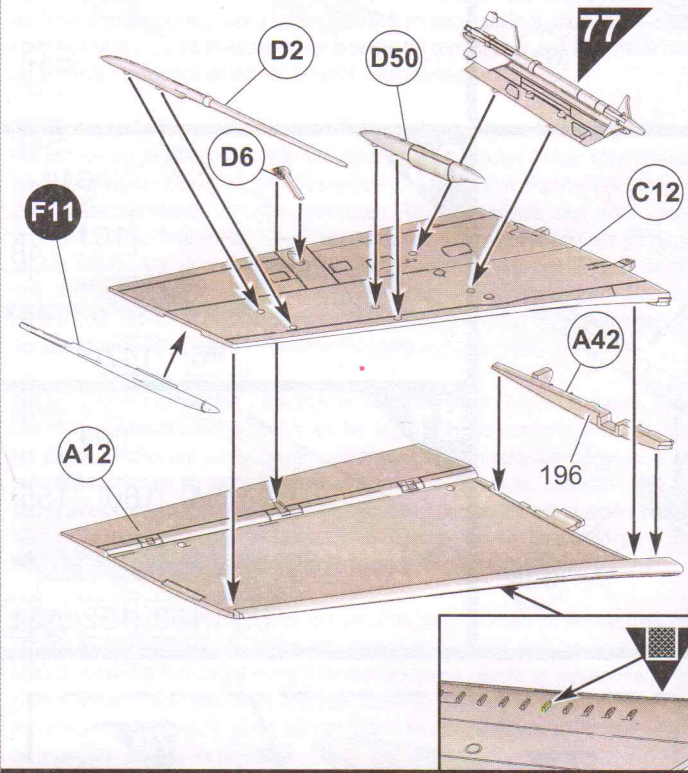
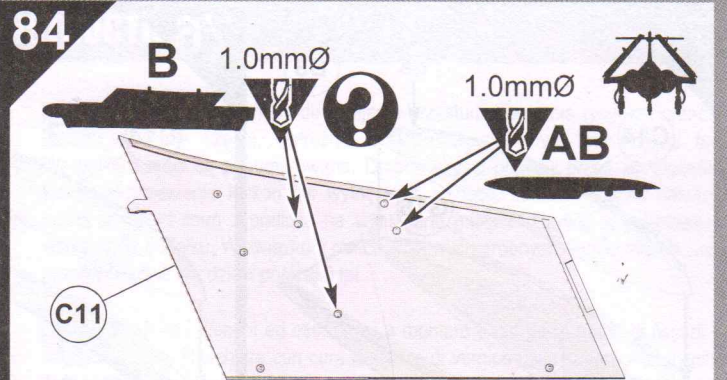
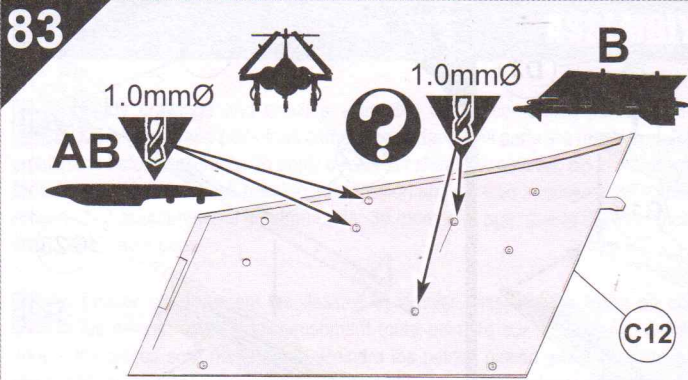

Airfix would like to thank the Ulster Aviation Society, in particular Tony Osborne, as well as Andy White for their help with this project.



# Ⓐ Blackburn Buccaneer S.2B

No. 208 Squadron, Royal Air Force Lossiemouth, Moray, Scotland, June 1990.  
Aircraft currently preserved at the Ulster Aviation Society, Northern Ireland.

- |  |  |                                     |
|--|--|-------------------------------------|
|  |  |                                     |
| <b>11</b><br>Silver                    | <b>33</b><br>Matt Black                  | <b>53</b><br>Gun Metal              |
|  |  |                                     |
| <b>93</b><br>Matt Desert Yellow        | <b>127</b><br>Satin US Ghost Grey        | <b>163</b><br>Dark Green BS381C 241 |
|  |  |                                     |
| <b>164</b><br>Dark Sea Grey BS381C 638 | <b>165</b><br>Medium Sea Grey BS381C 637 |                                     |

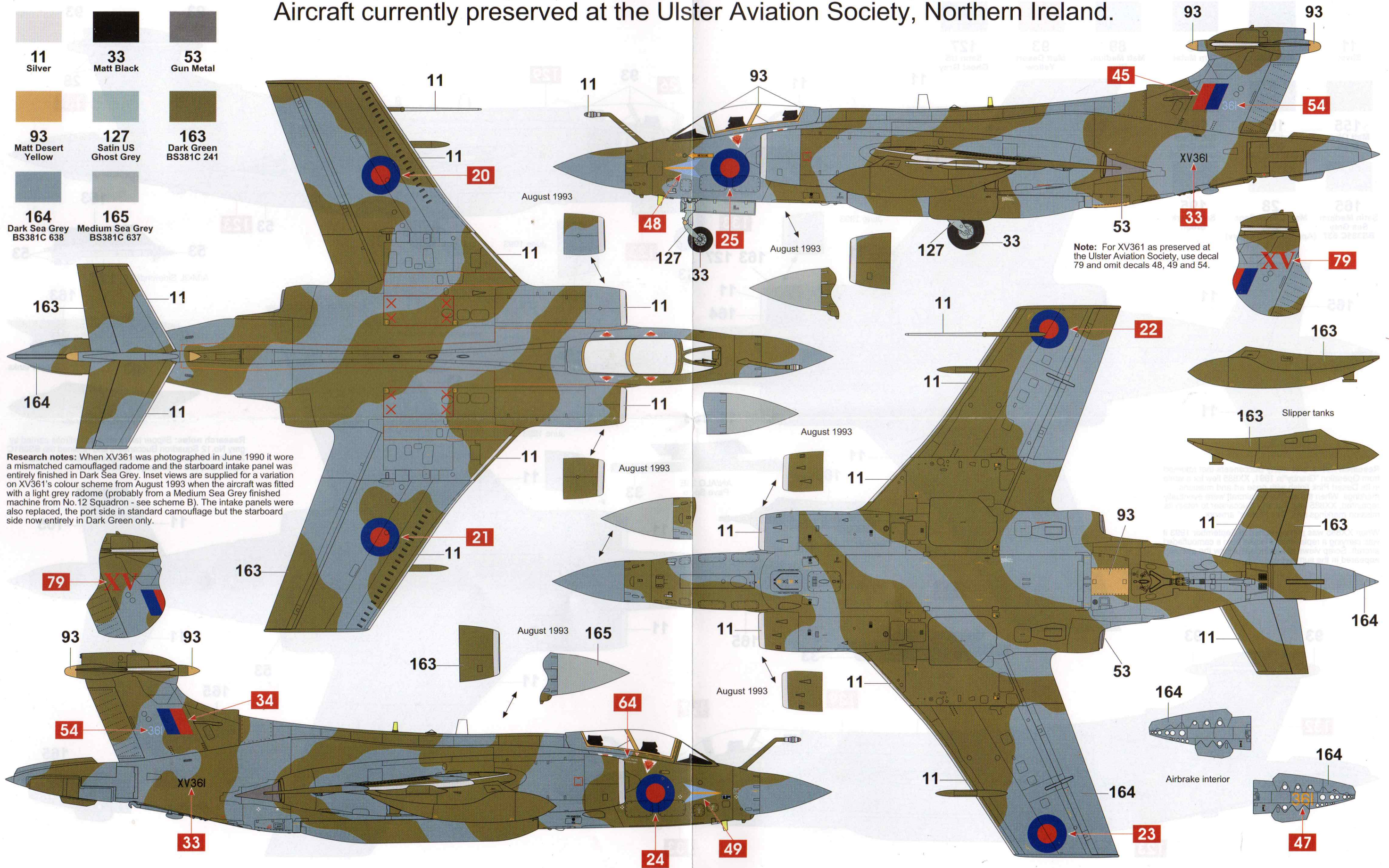

**Research notes:** When XV361 was photographed in June 1990 it wore a mismatched camouflaged radome and the starboard intake panel was entirely finished in Dark Sea Grey. Inset views are supplied for a variation on XV361's colour scheme from August 1993 when the aircraft was fitted with a light grey radome (probably from a Medium Sea Grey finished machine from No.12 Squadron - see scheme B). The intake panels were also replaced, the port side in standard camouflage but the starboard side now entirely in Dark Green only.

Note: For XV361 as preserved at the Ulster Aviation Society, use decal 79 and omit decals 48, 49 and 54.

# B Blackburn Buccaneer S.2B

No. 12 Squadron, Royal Air Force Lossiemouth, Moray, Scotland, September 1993.

11 Silver	33 Matt Black	53 Gun Metal	89 Matt Medium Blue	93 Matt Desert Yellow	127 Satin US Ghost Grey
155 Matt Olive Drab	163 Satin Dark Green BS381C 241	164 Satin Dark Sea Grey BS381C 638			
165 Satin Medium Sea Grey BS381C 637	28 Matt Camouflage Grey (Approx. Barley Grey) BS381C 626	195 Satin Dark Green			

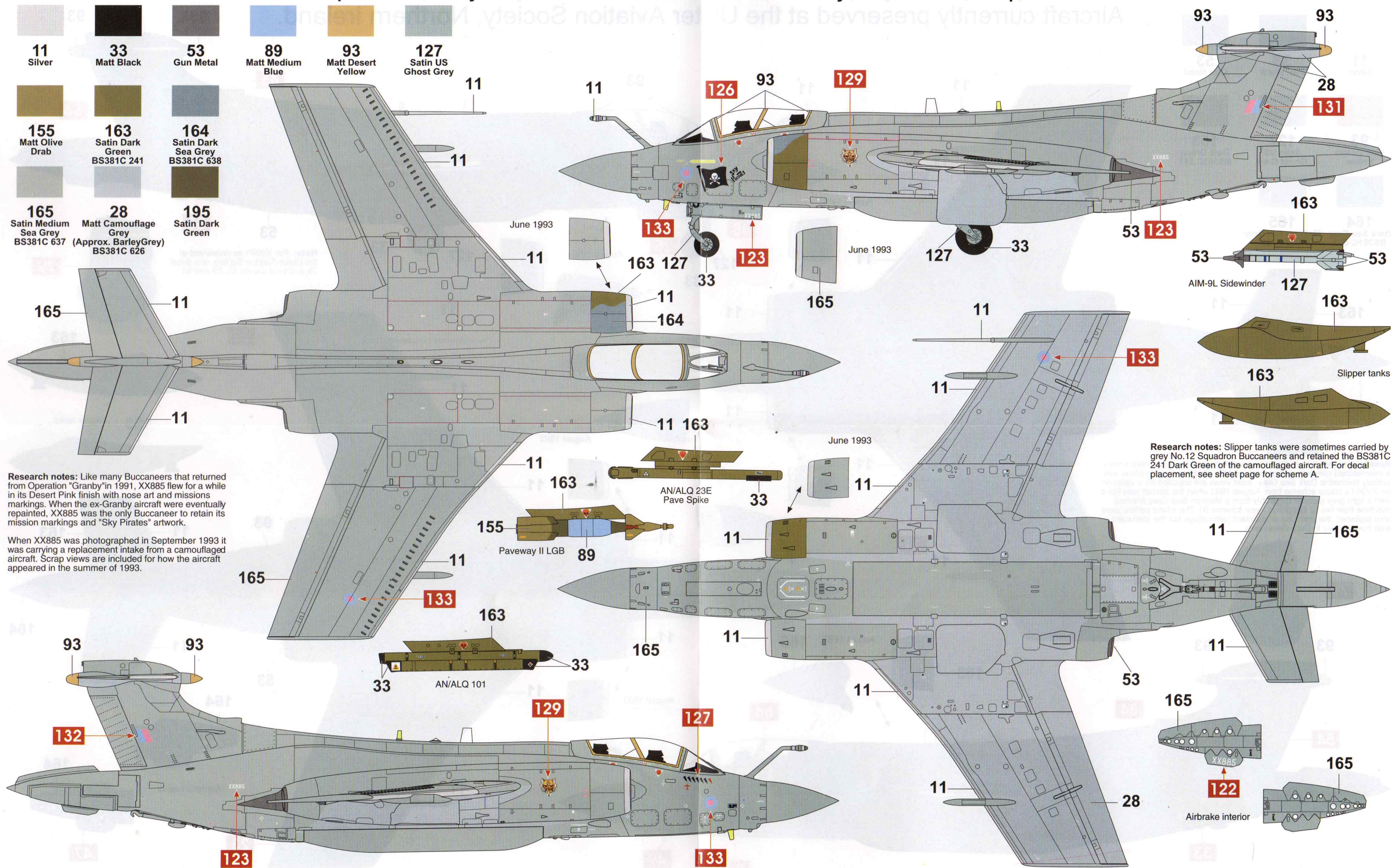

**Research notes:** Like many Buccaneers that returned from Operation "Granby" in 1991, XX885 flew for a while in its Desert Pink finish with nose art and mission markings. When the ex-Granby aircraft were eventually repainted, XX885 was the only Buccaneer to retain its mission markings and "Sky Pirates" artwork.

When XX885 was photographed in September 1993 it was carrying a replacement intake from a camouflaged aircraft. Scrap views are included for how the aircraft appeared in the summer of 1993.

**Research notes:** Slipper tanks were sometimes carried by grey No.12 Squadron Buccaneers and retained the BS381C 241 Dark Green of the camouflaged aircraft. For decal placement, see sheet page for scheme A.

# Ⓐ Blackburn Buccaneer S.2B

## Position of stencil data

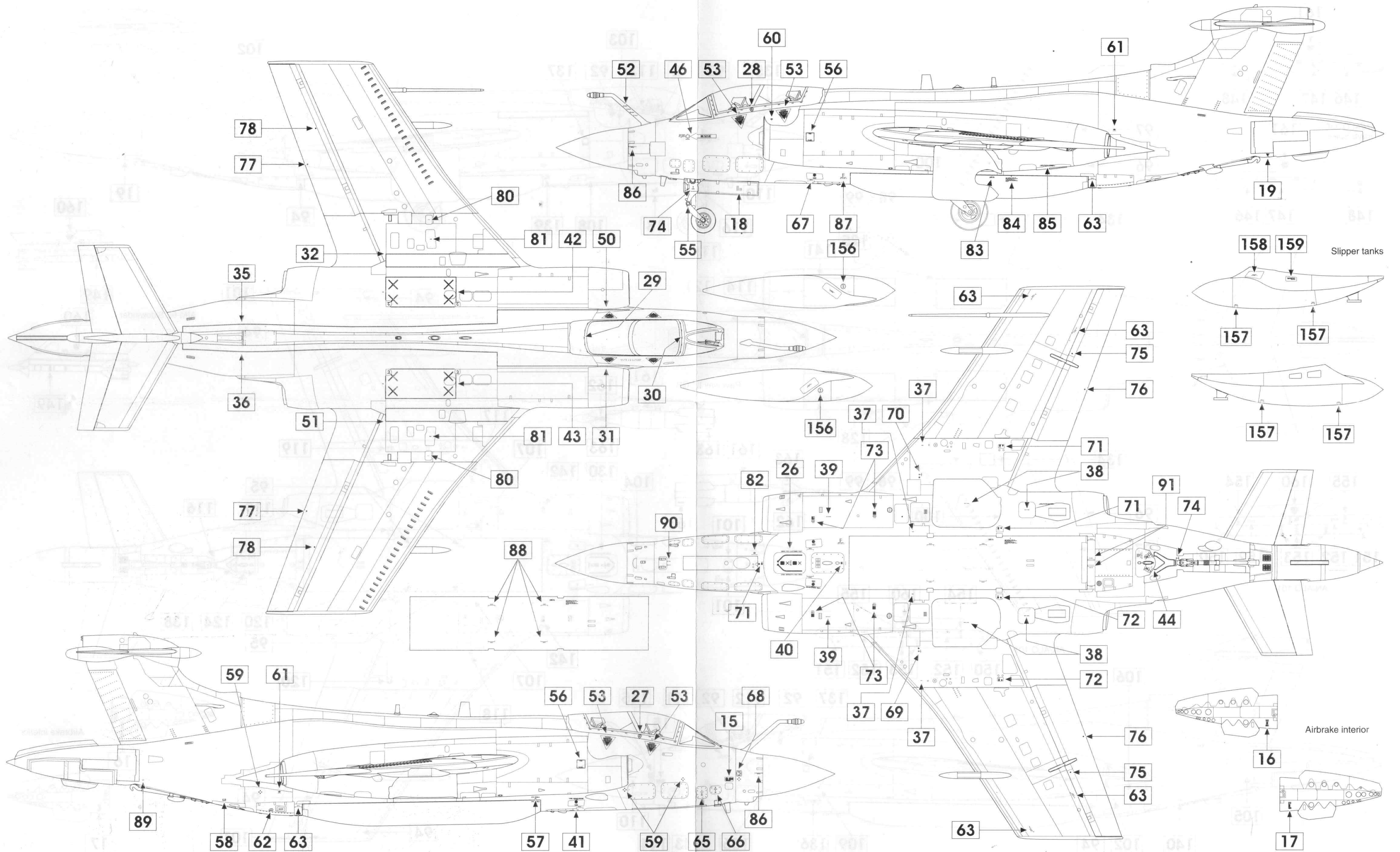

# Ⓑ Blackburn Buccaneer S.2B

## Position of stencil data

