

de Havilland DH.82A Tiger Moth

Plastic model

scale : 1/72

History in brief

Developed from the two-seat de Havilland Moth civilian trainer, a new military trainer was developed and given the name DH.60T Moth Trainer. Although not flown by the RAF, this military trainer was sold to Brazil, China, Iraq, Egypt and Sweden. Refined under Specification 15/31, the now-modified DH.60T was given the name Tiger Moth. This name was carried on to yet another modification to the basic design, Specification T.26/31, which became the DH.82A Tiger Moth, powered by a single de Havilland Gipsy Major engine. This new machine first flew on 26th October 1931 and the RAF ordered 35. The first deliveries were to No. 3 Flying Training School at Grantham, Lincolnshire in November 1931 and the Central Flying School in May 1932.

The Tiger Moth soon proved to be a popular aircraft and was sold to such countries as Brazil, Denmark, Persia, Portugal and Sweden. Before the outbreak of WW2, Norway and Canada joined Portugal and Sweden in building Tiger Moths under license and during the war, both Australia and New Zealand manufactured over 1,400 aircraft between them. Large numbers of Australian-built Tiger Moth were shipped to Southern Rhodesia and South Africa for use under the Commonwealth Air Training Plan which also operated in Canada where the Tiger was redesigned and adapted to local conditions by de Havilland Aircraft of Canada Ltd.

The Tiger Moth saw widespread use in WW2, as a trainer, air ambulance and light communications aircraft. Some were even fitted with light bomb racks and were used for coastal patrols to deter U-boats from operating in British waters. Many examples have survived into the 21st Century and can still be seen in the sky all around the world.

Plastic parts

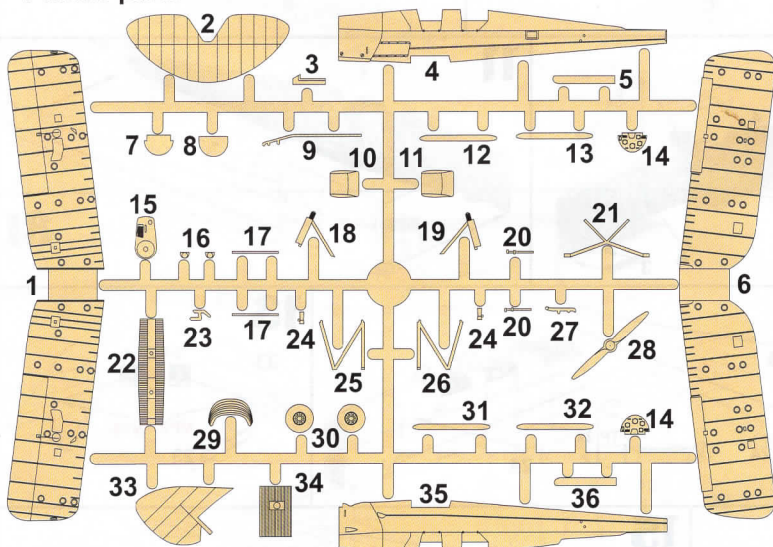

Metal parts

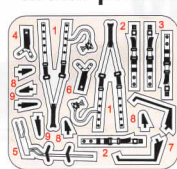

Transparent parts-foil

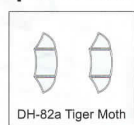

Symbols



	Colour name	Humbrol	Colour name	Humbrol
A	Black	H33	G Aluminium	H56
B	White	H34	H Silver	H11
C	Interior Green	H76	I Linen	H74
D	Gunmetal	H53	J Red	H132
E	Dark Grey	H27	K Tyre	H85
F	Yellow	H24	L Rust	H113

Assembly instructions

1 14(2x) Clear Fix A F B H H

2 30(2x) K

3 15 D

4 20(2x) A C

5 10 G 11

6 MP1 H I H H MP2 MP3 H H I MP3 MP2 MP1 H H I MP2 MP3

7 20 20 22 C

8 14(2x) A 16(2x) 35 8 14 7 14 C C

9

10 4 C A 3

11

12 TP TP 24 TP: 2x

13 33 23 0,2mm MP9 MP9

14 MP8 ϕ 0,2mm MP8 MP8 ϕ 0,2mm MP8

15

Assembly instructions

16

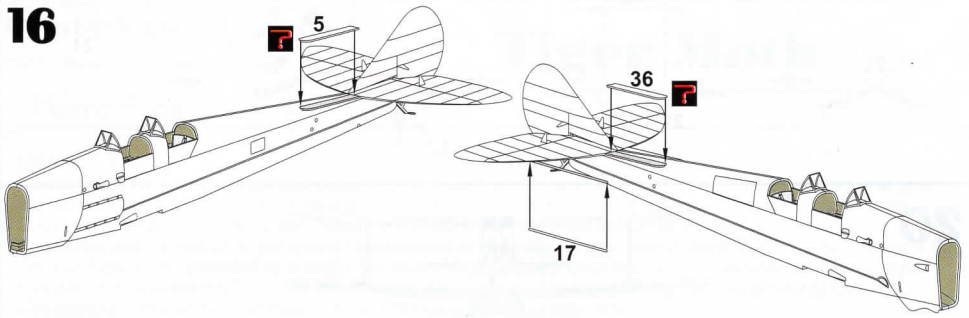

17

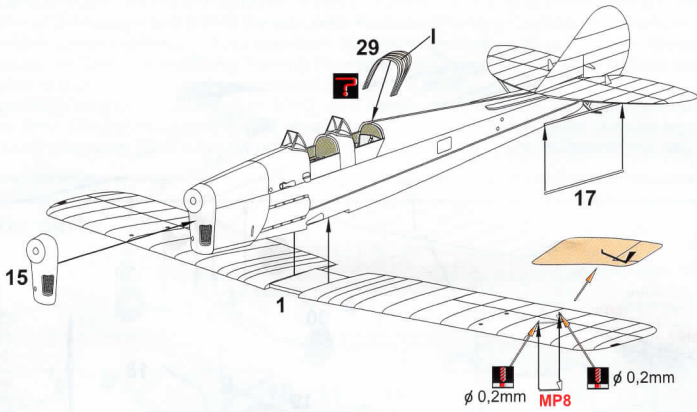

18

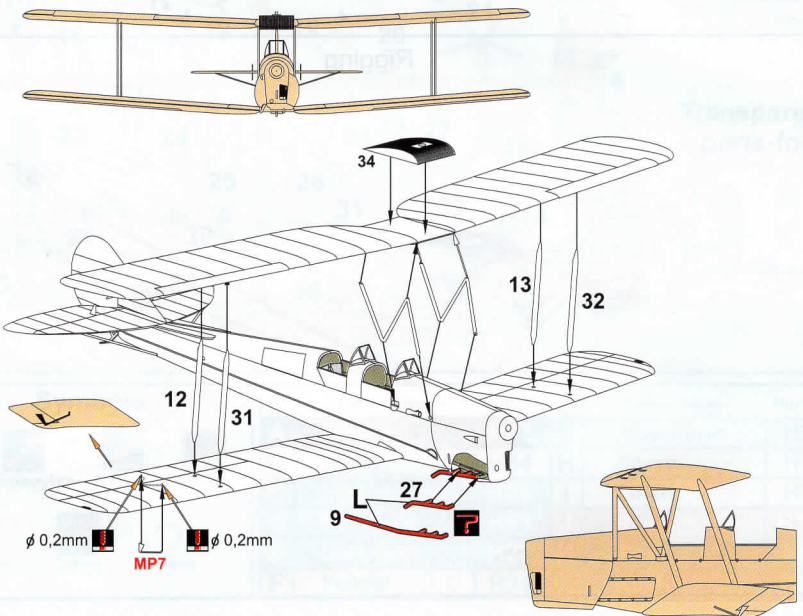

19

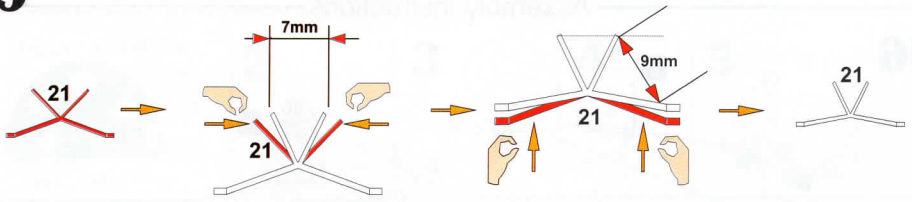

20

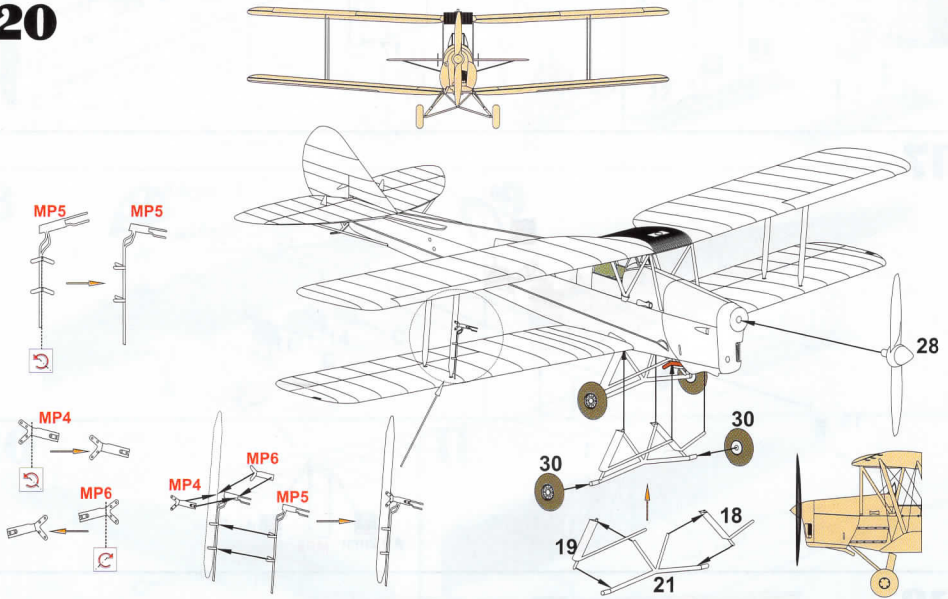

Rigging

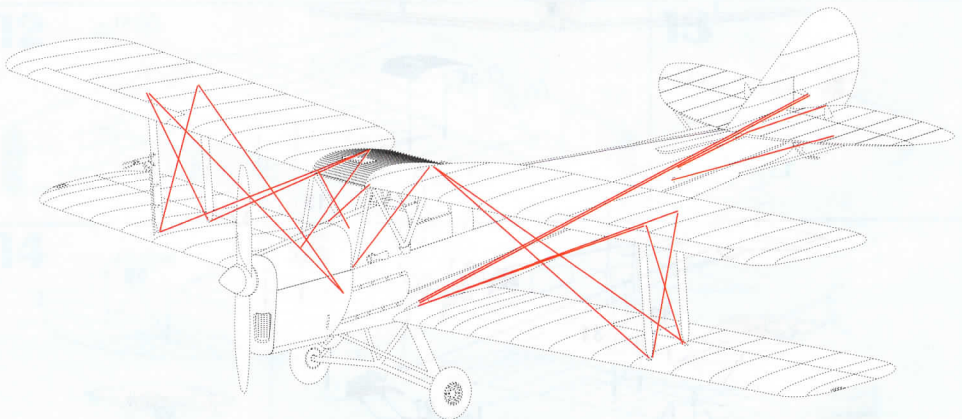

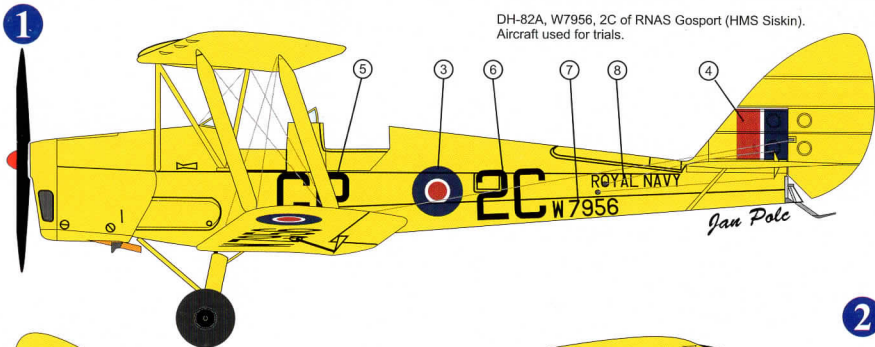

DH-82A, W7956, 2C of RNAS Gosport (HMS Siskin).
Aircraft used for trials.

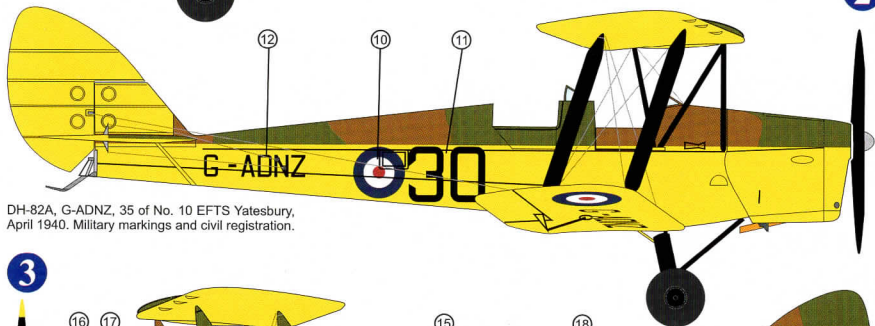

DH-82A, G-ADNZ, 35 of No. 10 EFTS Yatesbury,
April 1940. Military markings and civil registration.

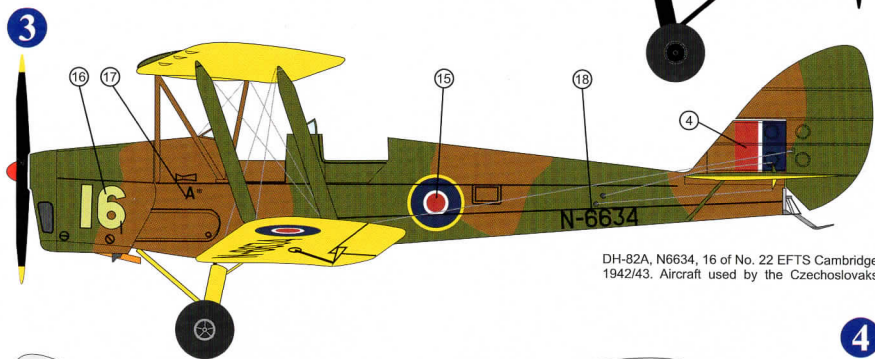

DH-82A, N6634, 16 of No. 22 EFTS Cambridge,
1942/43. Aircraft used by the Czechoslovaks.

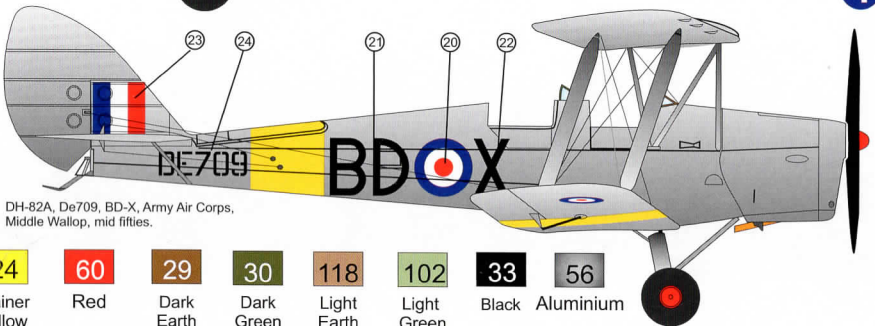

DH-82A, BE709, BD-X, Army Air Corps,
Middle Wallop, mid fifties.

24	60	29	30	118	102	33	56
Trainer Yellow	Red	Dark Earth	Dark Green	Light Earth	Light Green	Black	Aluminium

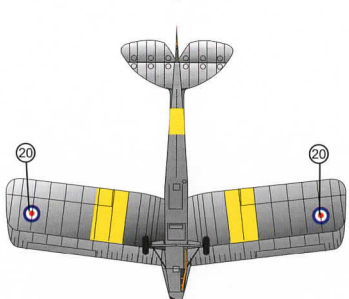
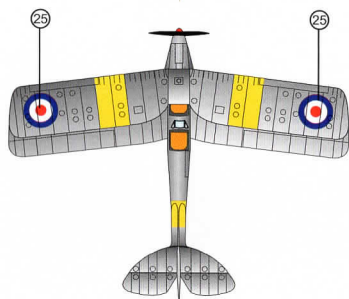
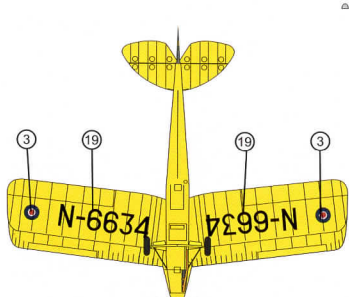
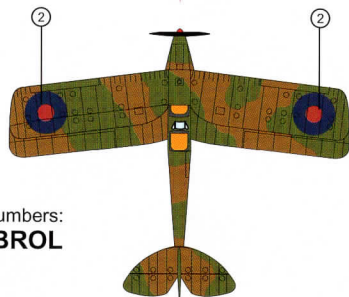
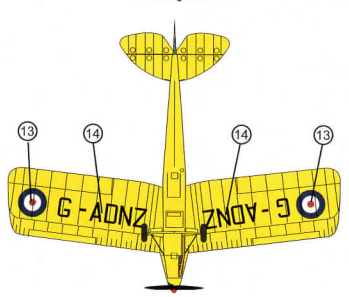
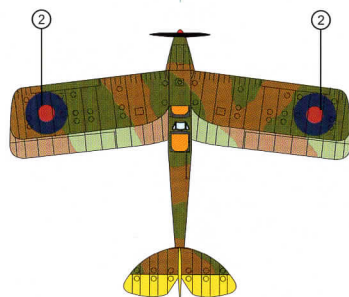
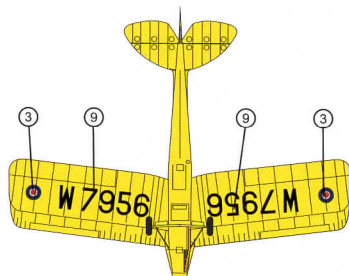
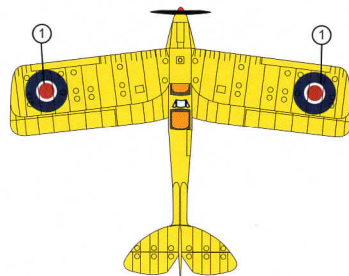

Paint Numbers:
HUMBROL