

**Yellowhammer
Models™**

YHD48039

1/48

F9F-2 Panther

For the Trumpeter &
Hobbycraft kits

F9F-2
VMF-311
K-3, South Korea, 1953



F9F-2B
VMF-311
K-3 Pohang, Korea, 1952

F9F-2
Blue Angels
1949 Demonstration Season



Hot Cats on Parade #2



Both birds were ground-based in South Korea and therefore extremely weather-beaten, dusty, streaked, and faded—especially #2. You can safely “go to town” on your weathering for these two subjects!

The aft end of this jet is removed in all available photos, so the BuNo is a valid F9F-2B serial and style of “WL” and “MARINES” is generally typical of those applied to VMF-311 jets at this time.

Details in paws are fine white lines, not colored as depicted in some published artwork

The outsides of the tip tanks are not visible in any available photo; we have assigned the number “1.” Other photos may later come to light showing a different number.

**F9F-2
VMF-311
K-3 Pohang, South Korea, 1952**

Red outline to mouth can be seen in good quality photos

NOTE: Teknicz has created several useful correction/ conversion sets you may find useful.

TK48085: F9F-2/3 Corrected Outer Wings With Tip Tanks Set
TK48089: F9F-2/3 “Down & Dirty” Conversion Set
TK48086: F9F-2/3 Corrected Fighter Nose
TK48091: F9F-2/3 Seamless Intakes for Trumpeter/HobbyCraft.
TK48092: F9F-2/3 Corrected Canopy

Check www.meteorprod.com for details.



**F9F-2B
VMF-311
Most Panther Combat Missions
During Korean War
K-3 Pohang, Korea, 1953**

Unknown whether the script was added to the right side nose number

Hot Cats on Parade #2

We've put considerable effort into obtaining the most accurate information possible on this jet so we could get it exactly right for you. We are deeply indebted to D'Ann Morris, the first-ever Blues female plane captain, and Blues historian John Keen, who obtained for us—from Dusty Rhodes logbook no less!—the BuNos of the two F9F-2 Panthers he flew during the 1949 demonstration season. Both BuNos are included on this sheet, although 122586 was his primary bird. We believe this information is presented here for the first time anywhere.

Note our Blue Angels badge decal does NOT have a white underlay under the yellow lower left quadrant. This is because the original (real) decal on these jets didn't either (!), causing the yellow to become significantly darker due to the "bleed through" of the dark blue paint under the decal. While this may look odd to you, it is completely correct as verified in many color photos of these jets.

Note the style, shape, and spacing of the "U.S.NAVY" is completely different between the fuselage and wings. Again, this is verified by many photos and our decals precisely replicate the size, style, shape and spacing on the original birds.

Photos of these birds show the guns still installed (or at least barrels sticking through the gun parts). The long vertical gun gas vents molded onto the Trumpeter nose were not even designed at the time these birds were flying with the Blues, so remove them from your model.

The yellow markings were NOT the orangish-yellow later used by the Blues, but rather a much paler yellow similar to FS 13655. Our decals are the correct color for the 1949 team.

The "Blue Angels Blue" color used by the F9F-2 and -5 Panthers was mixed and applied at Grumman using THREE parts ANA 623 Glossy Sea Blue to one part ANA 511 Insignia White. This resulted in a much darker blue color than modelers typically believe was used on these early jets. The confusion probably comes from the fact that a MUCH lighter blue mixed from TWO parts Glossy Sea Blue to one part Insignia White was used on the F9F-8 (in 1955) all the way through to the F11F-1 Tigers in 1958. Unfortunately no FS 595B color is even remotely close to this mix, so you're on your own to mix it from existing model paints.

Note the nearly complete lack of stenciling on these birds except for the tip tank fueling instructions and canopy removal warning.

F9F-2
LCDR Raleigh E. "Dusty" Rhodes
Team Leader
Blue Angels
1949 Demonstration Season

The Blue Angels Blue special mix color was 3 parts Insignia Blue to 1 part Insignia White

Blue Angel Blue
 special mix



NOTE: the Blues flies WITHOUT tip tanks for the first part of the 1949 season. Tankless wings are available in Teknic's conversion set TK48088 (see below)

NOTE: Teknic's has created several useful correction/ conversion sets you may find useful.

TK48088: XF9F-2/3 Prototype Conversion Set
 TK48085: F9F-2/3 Corrected Outer Wings With Tip Tanks Set
 TK48089: F9F-2/3 "Down & Dirty" Conversion Set
 TK48086: F9F-2/3 Corrected Fighter Nose
 TK48091: F9F-2/3 Seamless Intakes for Trumpeter/HobbyCraft.
 TK48092: F9F-2/3 Corrected Canopy

Check www.meteorprod.com for details.

Note no unpainted metal leading edges for tail or stabilizer

Special thanks to Mike "Eagle Eyes" Lampros



...available from

Meteor

Productions Inc.

P.O. Box 3956, Merrifield, VA 22116 USA

☎ 703/440-8720 FAX 703/440-8724

www.meteorprod.com

Write, call, or visit our home page to order our decals, kits, conversions, tools, books, magazines, etc., and we'll send it to you right away!

© Yellowhammer Models, 2007

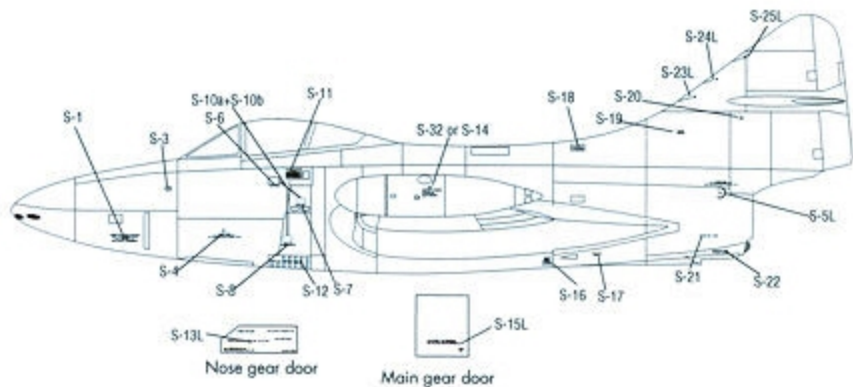
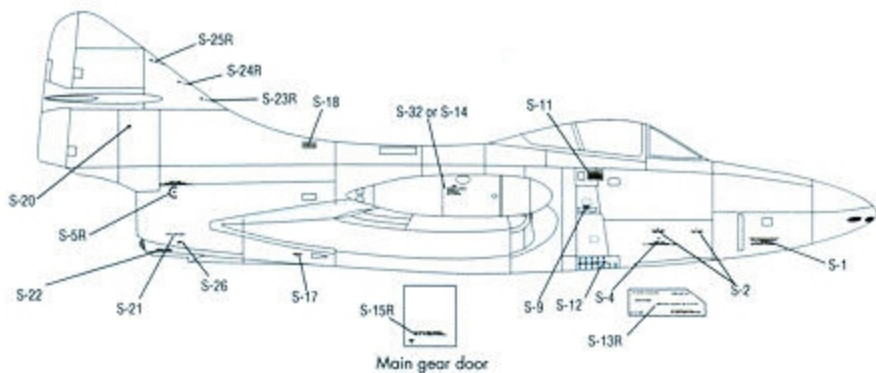

1/48 templates for upper blow in doors

