

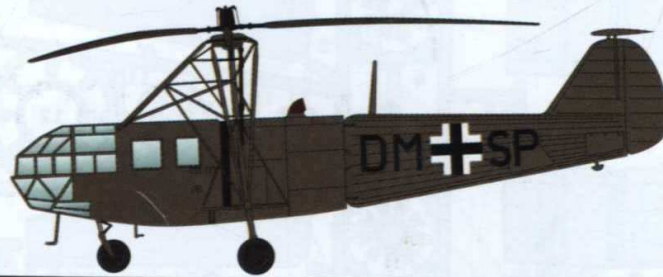

# 1/72 SCALE MODEL CONSTRUCTION KIT Focke Achgelis Fa 223



72003

The first prototype V1 of Fa-223 helicopter was built by Focke-Achgelis in 1939 and made its first untethered flight on 3 August 1940 after over 100 hours of ground and tethered testing with Karl Bode at the controls. The first production version of multipurpose F 223E was production ready by 1941 but only about 20 machines were built by the end of the war.

Two Fa 223s designated as VR-1 were completed by the Československé závody Letecké (formerly Avia) factory in Czechoslovakia in 1945–1946 from salvaged components.

Вертоліт Fa-223 був побудований фірмою «Focke-Achgelis» в 1939. Прототип Fa 223 V1 випробували в жовтні 1939. Капітан Карл Боде 3 серпня 1940 здійснив на ньому перший політ.

З 1941 до серійного виробництва підготували модель Fa 223 E, як багатоцільового вертольота.

До кінця війни вдалося зібрати близько 20 вертольотів. Після війни, в Чехословаччині на заводі Avia зібрали 2 Vr-1 із запчастин Fa 223.

### Технічні характеристики / Technical specifications:

Довжина/Length - 12,25 м; Діаметр ротора/Rotor diameter - 12,00 м; Висота/Height - 4,35 м; Злітна вага (макс.)/Loaded weight - 4315 kg; Дальність польоту/Range - 700 км; Крейсерська швидкість/Cruising speed - 120 км/ч; Макс. висота польоту/Ceiling - 4880 м; Кількість пасажирів/Number of passengers - 4.

### СПЕЦІАЛЬНІ СИМВОЛИ / USED SYMBOLS



### КОЛЬОРИ ФАРБ / USED PAINTS



**PARTS OF THE MODEL**

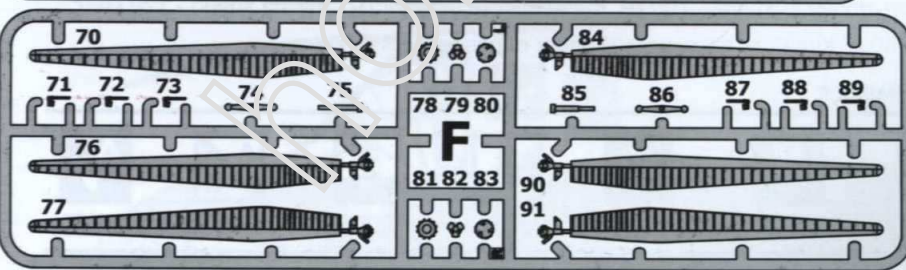
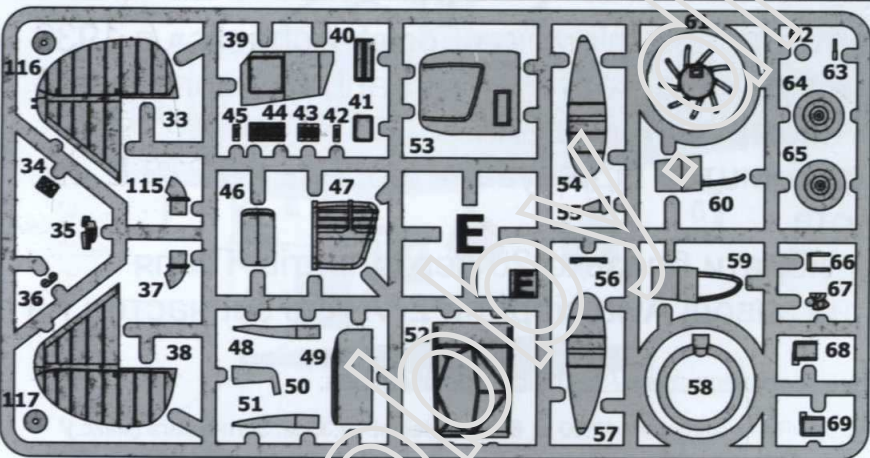
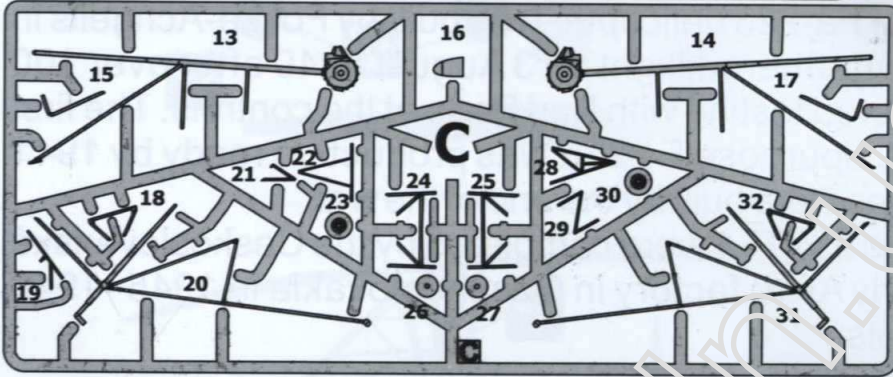
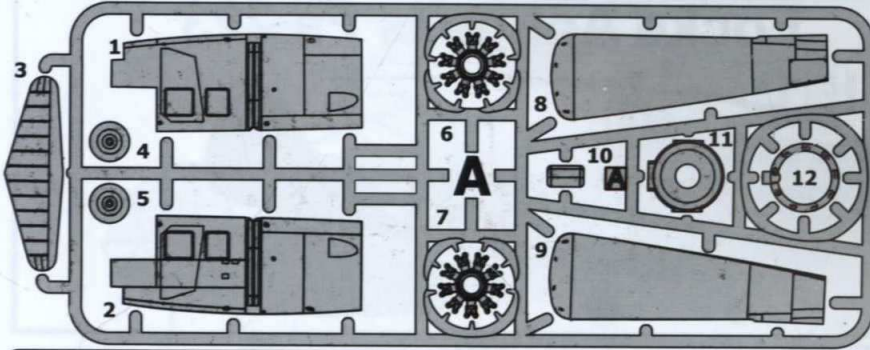

**PE**

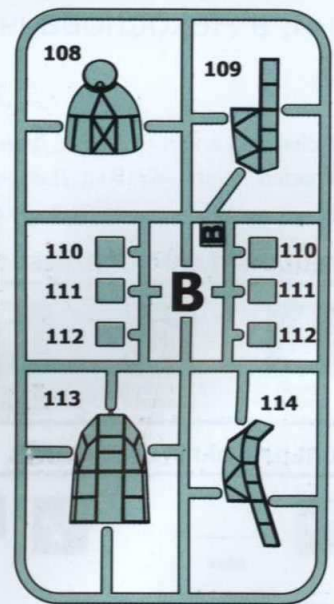
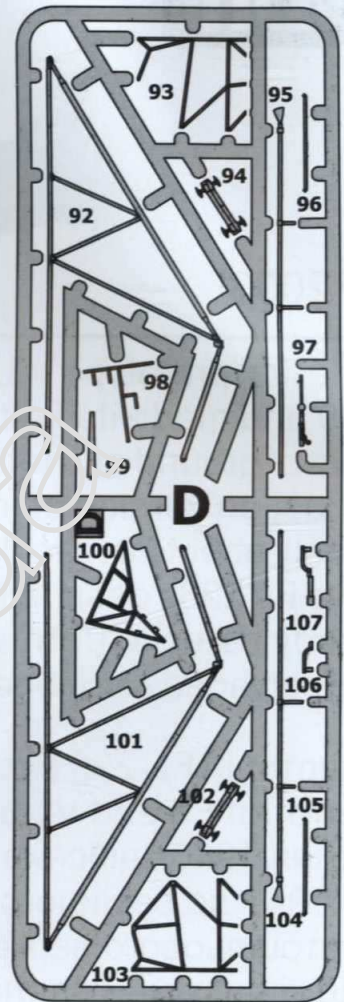

# ASSEMBLY INSTRUCTION

**1** E59,E60



**4** A10,E47,E49,E52,E53,E59-60,D93,D103

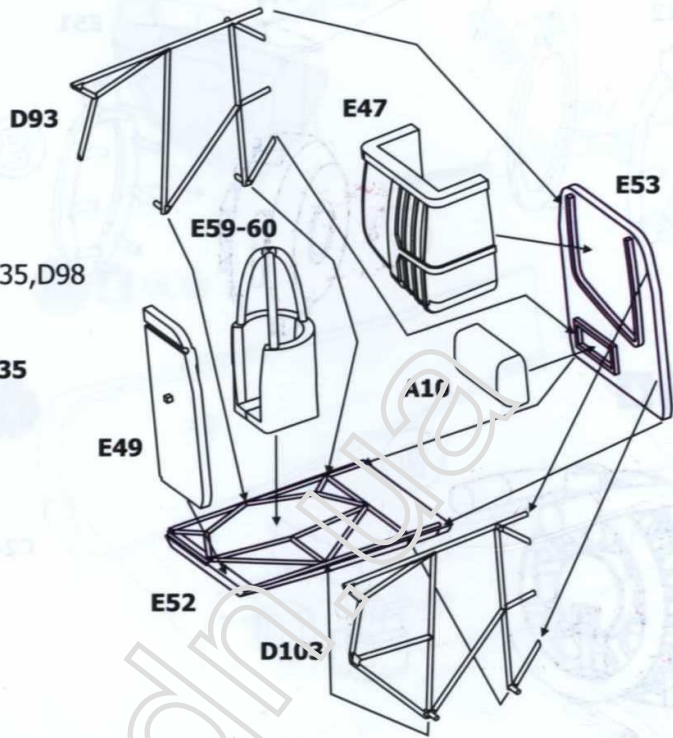

**2** E42,E43,E44,E45,D100

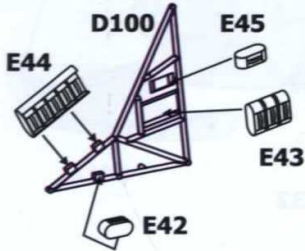

**3** E34,E35,D98



**5** E40,E41,E46,E55,E56,C19,C22,C28,C29

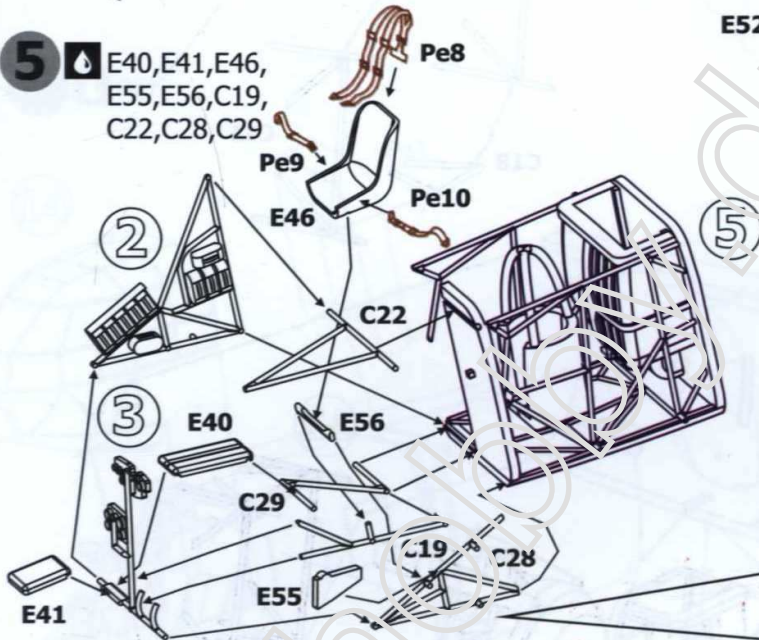

**6** Pe6

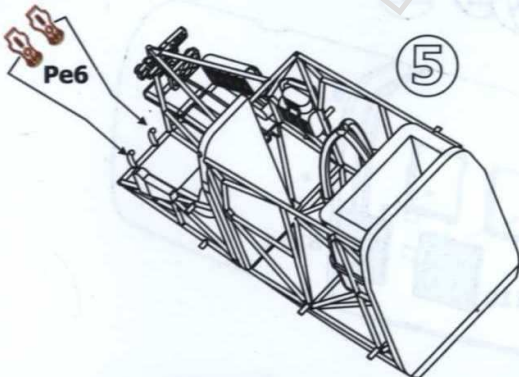

**7** A6,A7,A11,E61

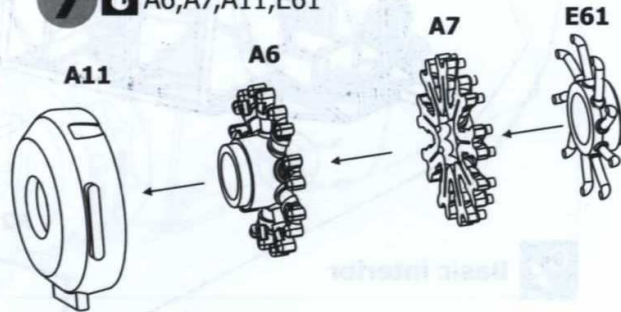

8 A12,E58



9 E48,E51

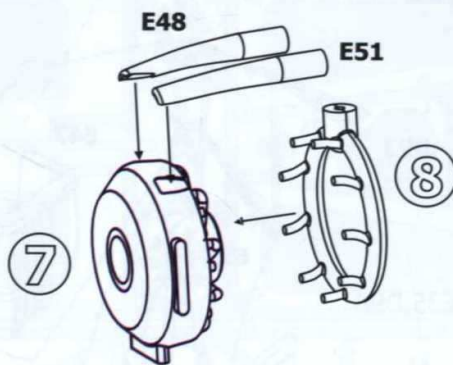

10 E50,E67,E68,E69

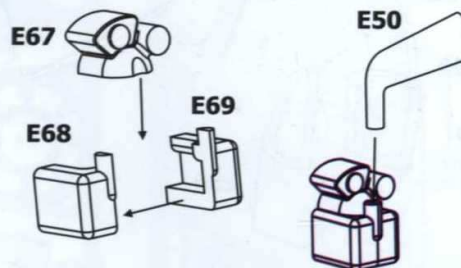

11

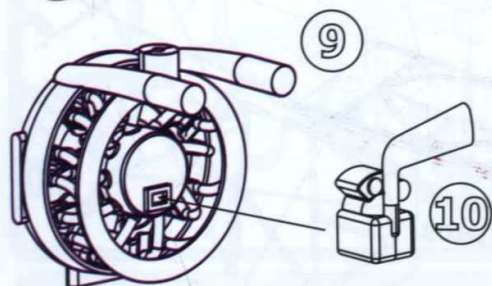

12 C18,C24,C25,C32

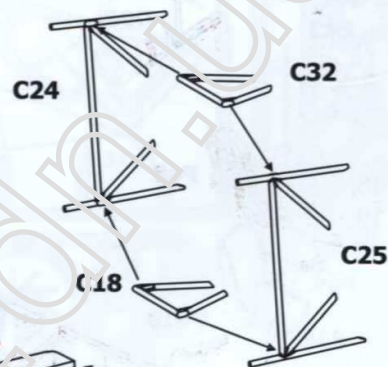

13 A1,A2,B110x2,B111x2

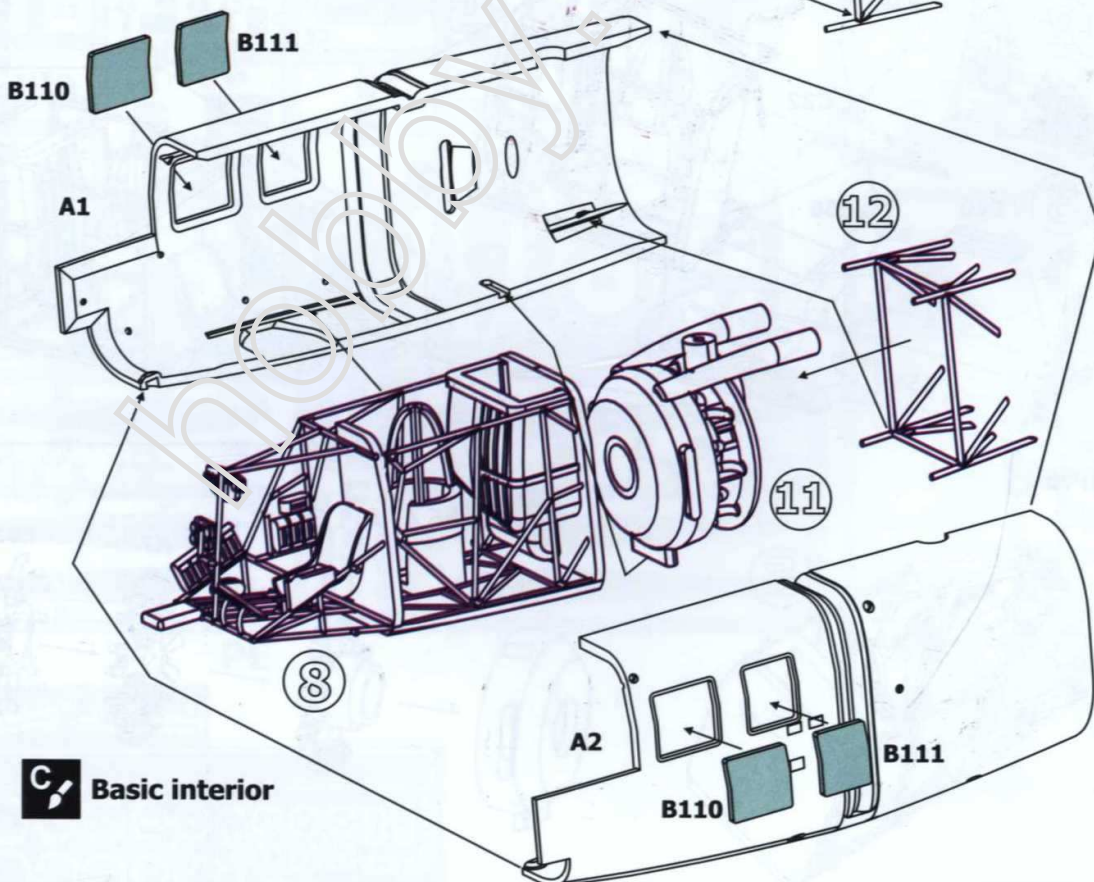

 Basic interior

14 A108,A109,A113,A114

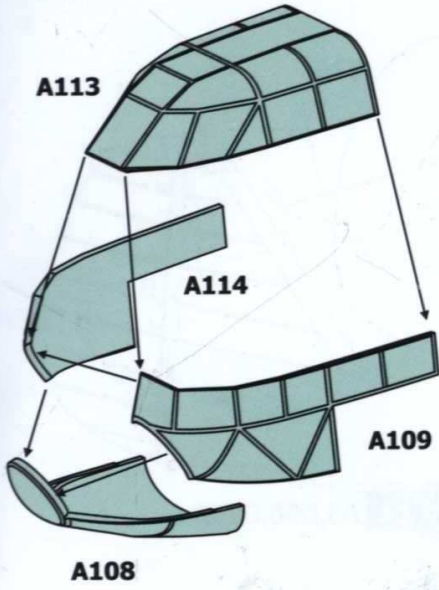

13 E36,D97,Pe7

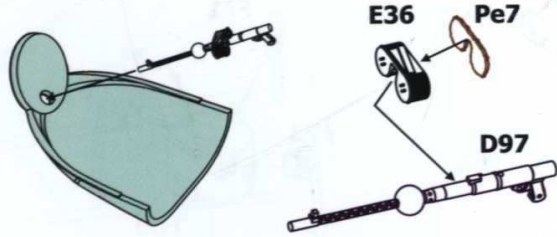

15 A8,A9

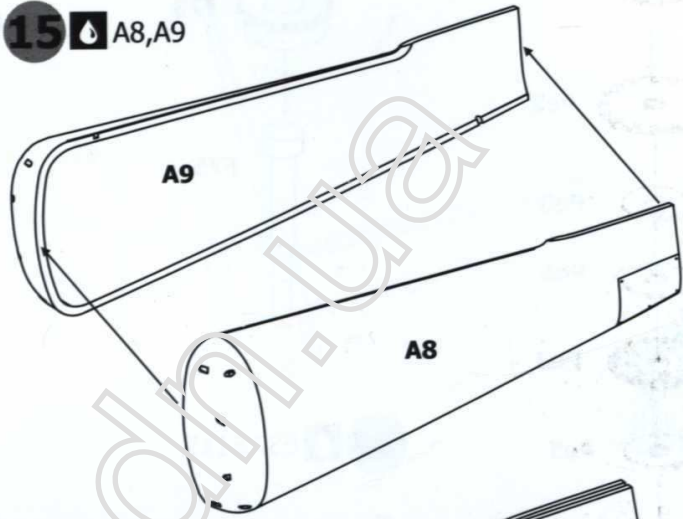

16 Pe1

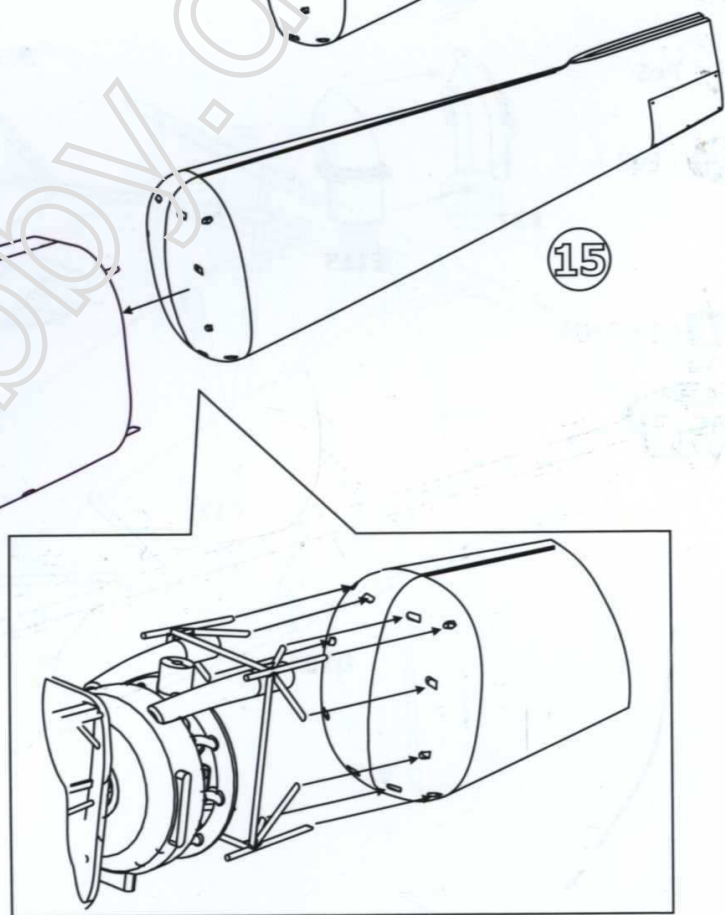
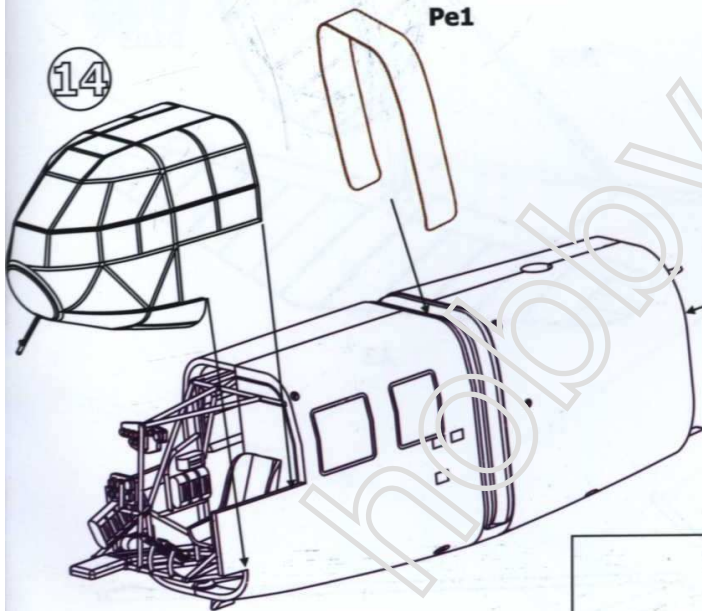

**17** Pe2-5

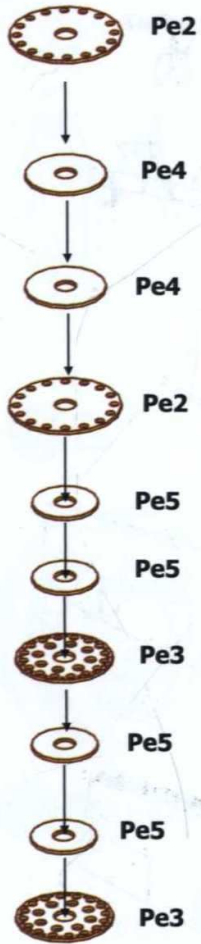

**18** F71,F72,F73,F75,F78,F80

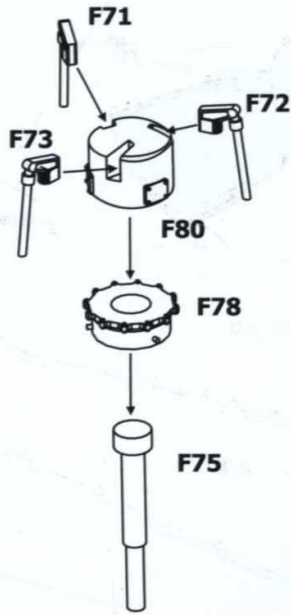

**19** E38,E33

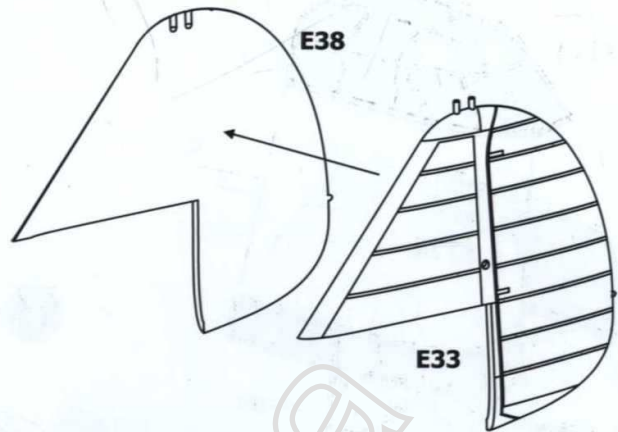

**20** A3,D96,D105

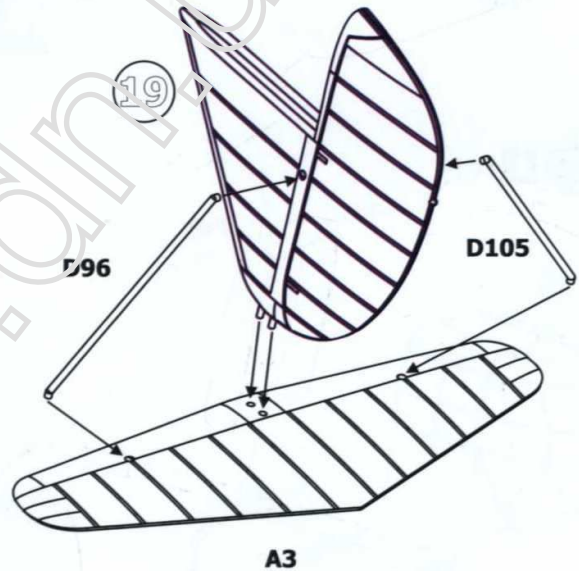

**20** E37,E115



**22** C13,D104

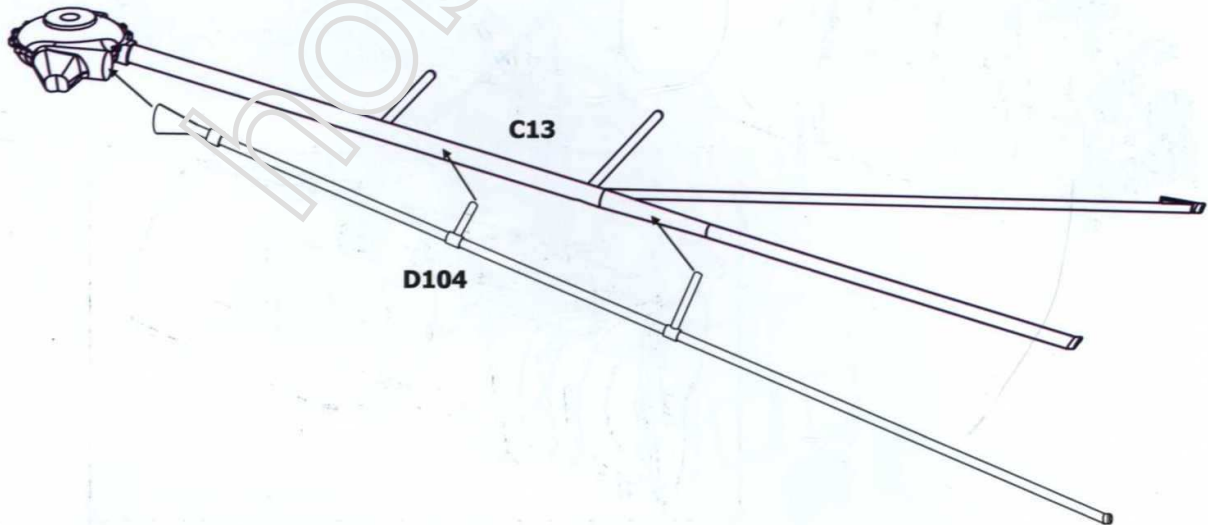

23  C20

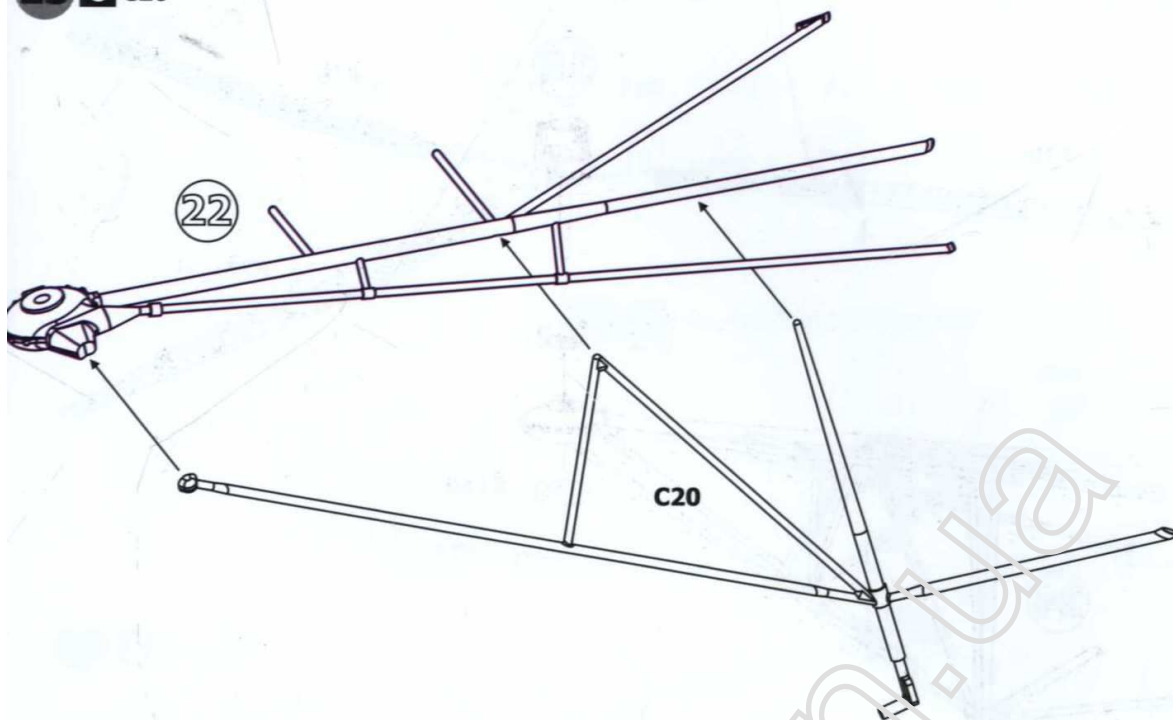

24  D92,C15

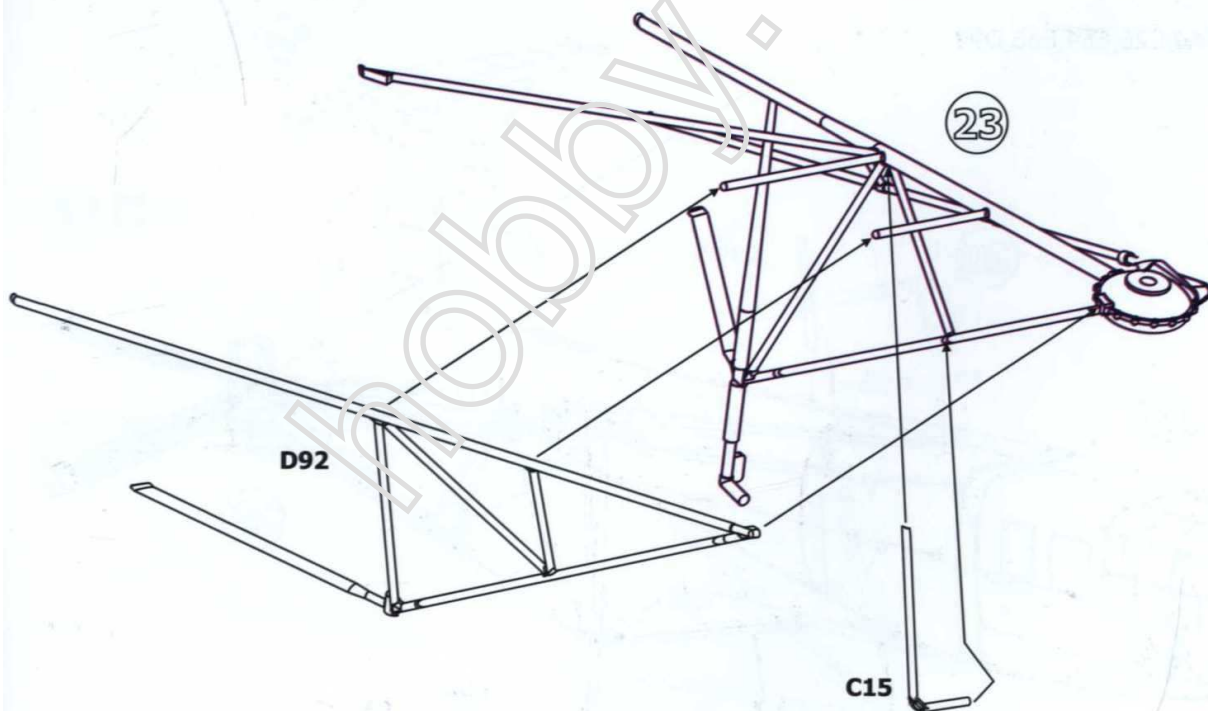

**25** E116,F70,F74,F76,F77

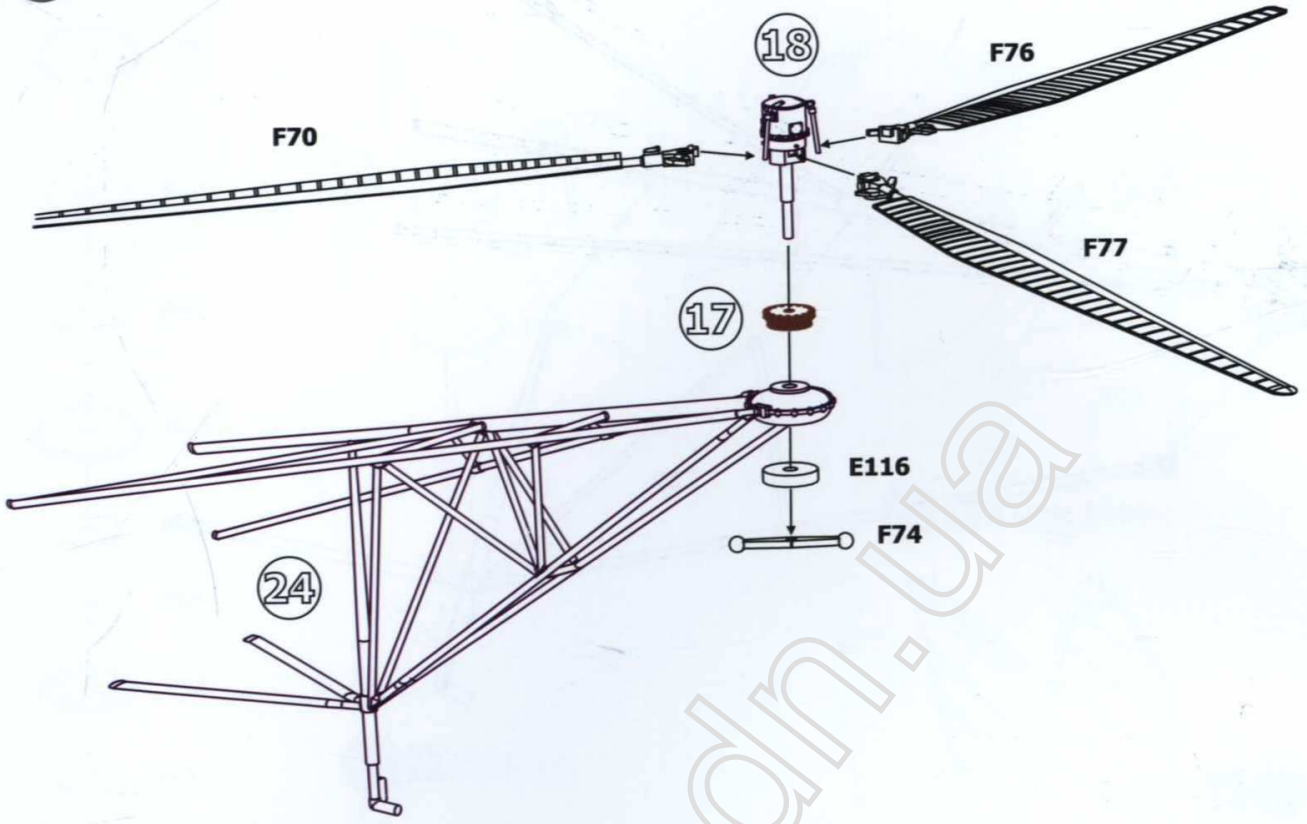

**26** A4,C26,E64,E66,D99

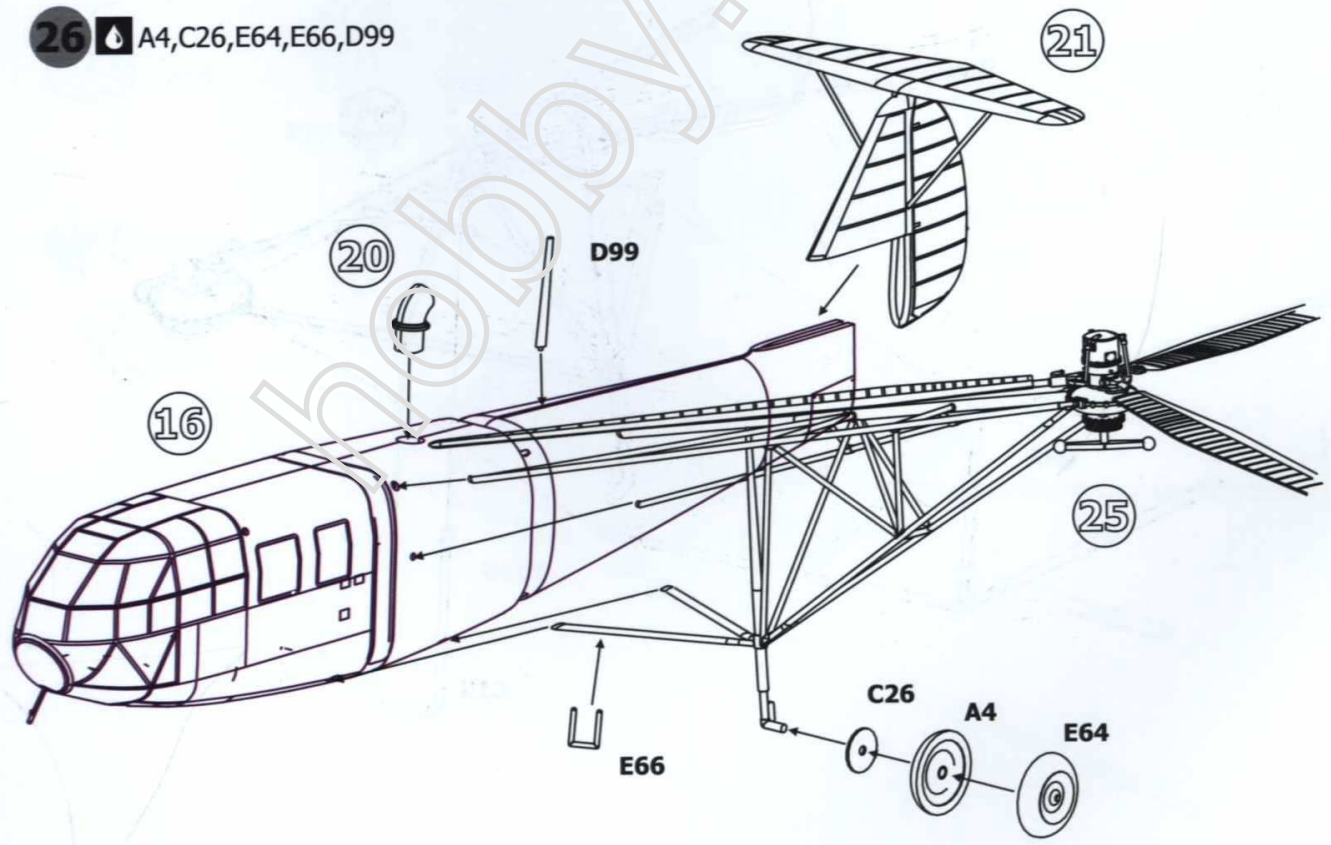



**27** Pe2-5

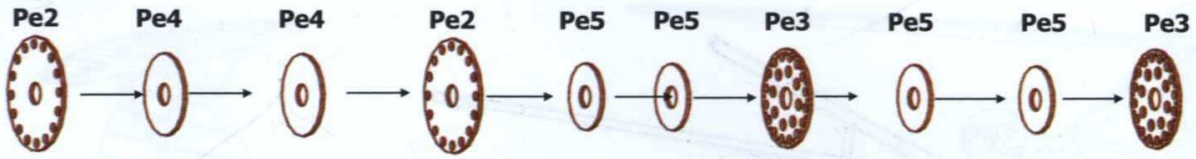

**28** F81,F83,F85,F87,F88,F89

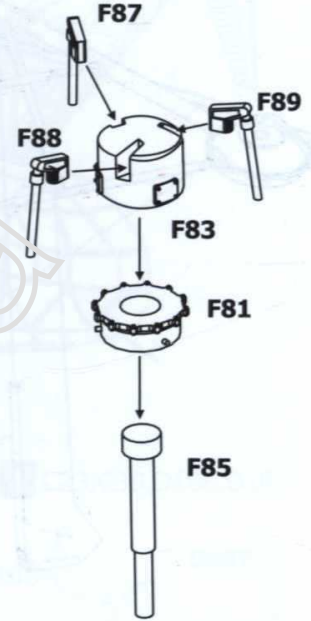

**29** C14,D95

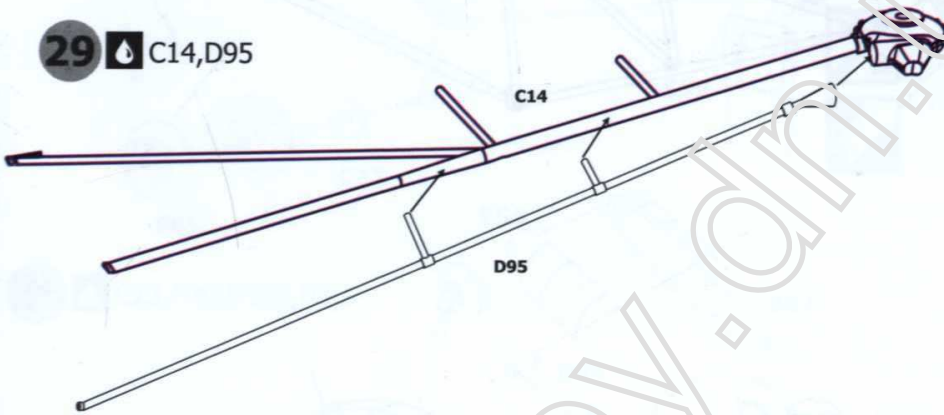

**30** C31

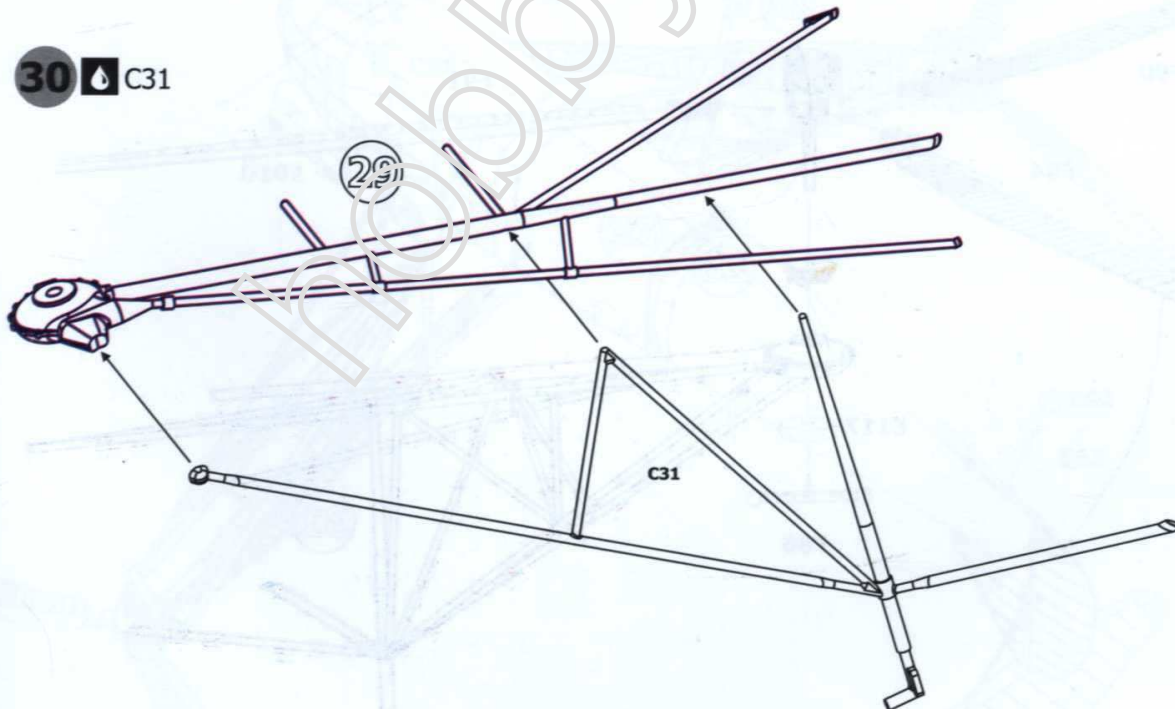

**31** C17,D101

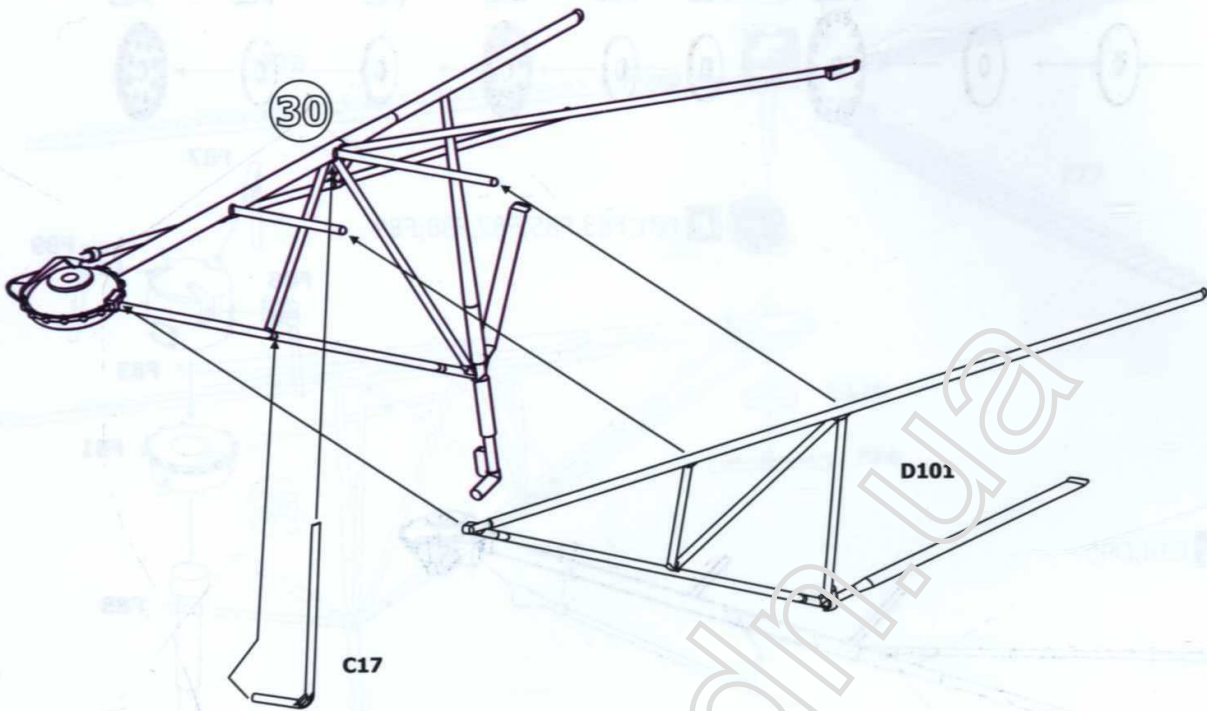

**32** F84,F86,F90,F91,E117

