

P-47 Thunderbolt

P-47N, 19th FS/319th FG, Saipan, Japan, 1945

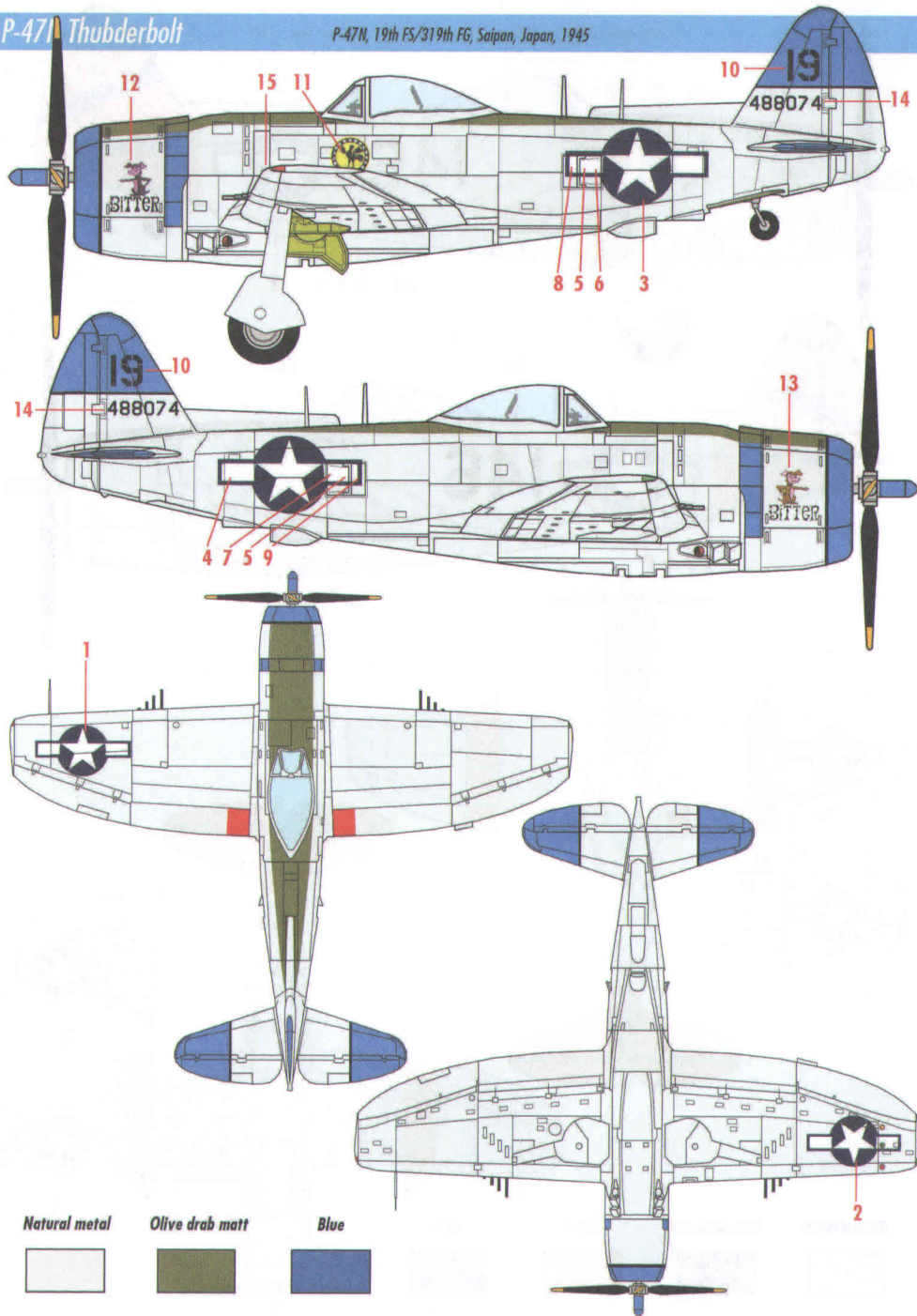

SW 72121 2 in 1

Republic P-47N

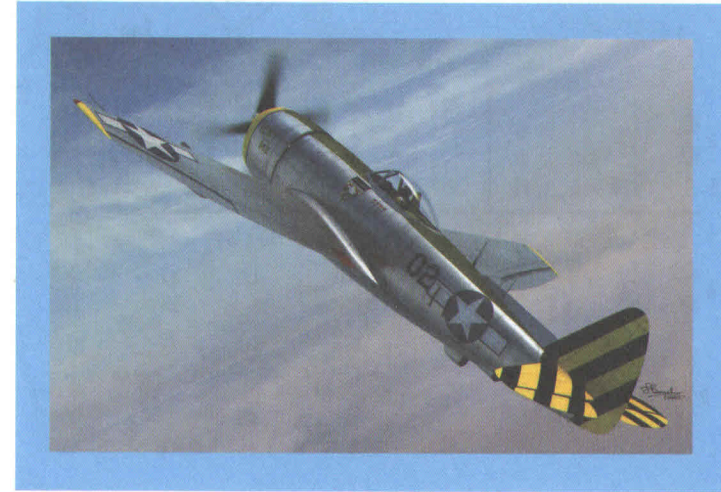

The P-47N was the last P-47 Thunderbolt variant to be produced. Expecting an Allied invasion of Japan, U.S. air experts decided in 1944 to improve the famous World War II fighter, the P-47 Thunderbolt. N version was designed as an escort fighter for the B-29 Superfortress bombers flying raids on the Japanese home islands.

Range was the main concern, therefore N introduced new longer-span "wet" wings with clipped wingtips giving this version a remarkable range of 2350 miles. Like all Thunderbolts, P-47Ns had a Pratt & Whitney R-2800 engine driving a massive 12-foot four-bladed propeller. Some subversions had a raised dorsal fin extension. The P-47N was one of the first fighters to have an automatic pilot for long-distance flying. A total of 1,816 P-47Ns was produced. The very last Thunderbolt to be built, a P-47N-25, rolled off the production line in October 1945.

P-47N arrived too late to see a combat in Europe, but Pacific sky saw flying P-47Ns from spring 1945. They started to fly from Saipan as escort fighters, but later were used also in fighter-bomber role with HVAR rockets and bombs. After WWII P-47Ns continued to serve in the USAAF/ U.S. Air Force in SAC, TAC and ADC squadrons. In 1948 the Thunderbolt was redesignated the F-47. As more jet fighters came into the inventory, the USAF phased out the F-47 in 1949, but the Air National Guard continued to use it into the mid-1950s.

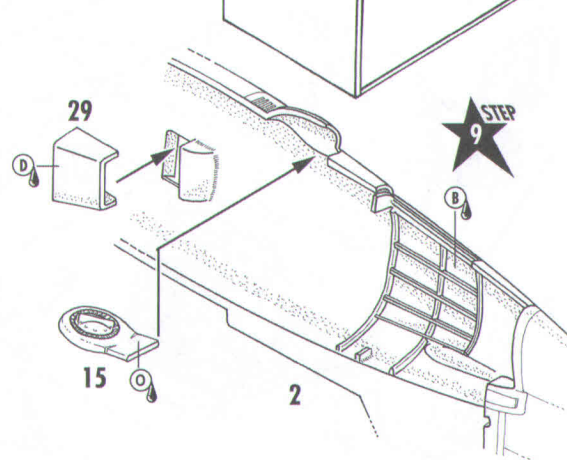
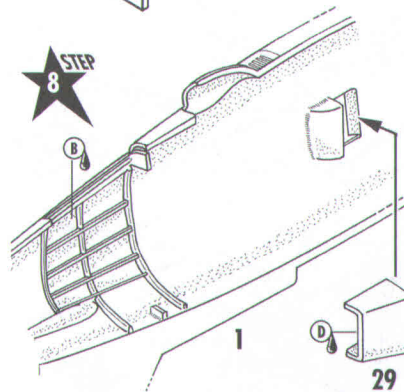
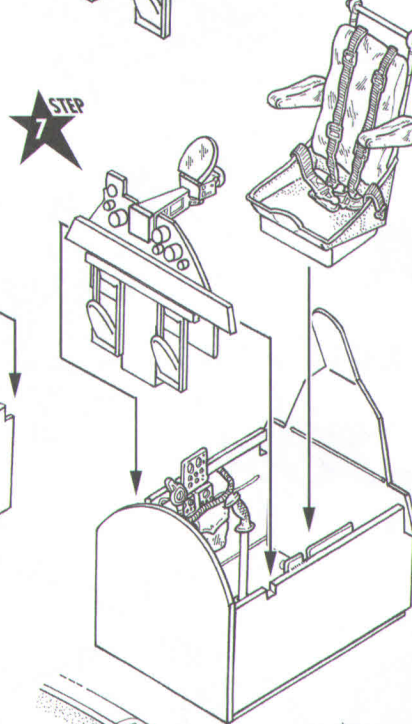
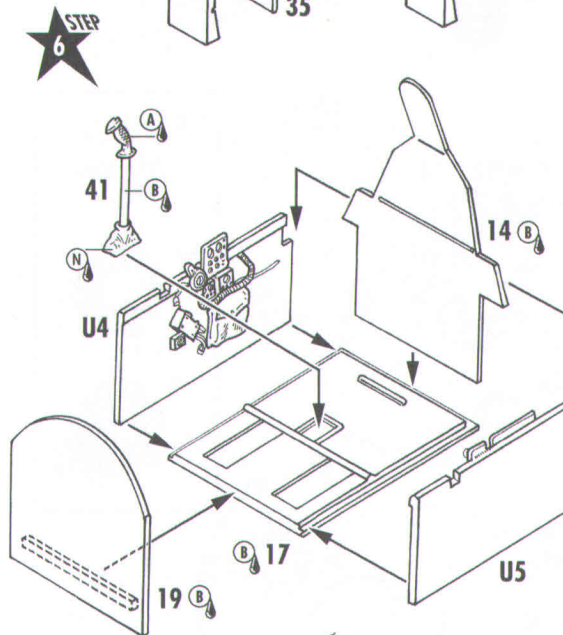
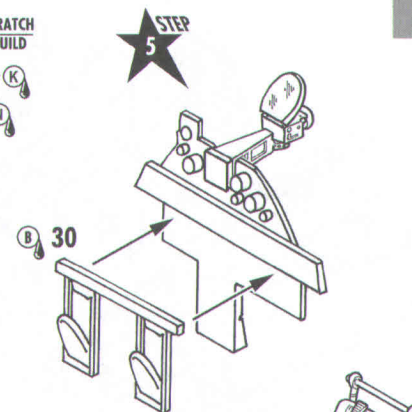
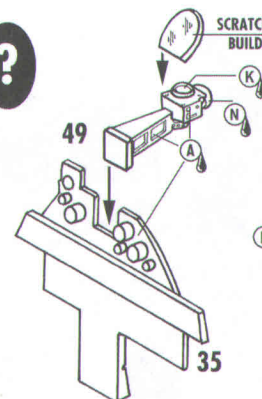
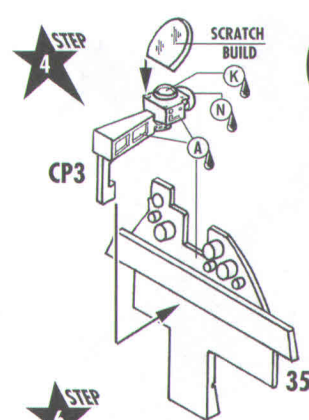
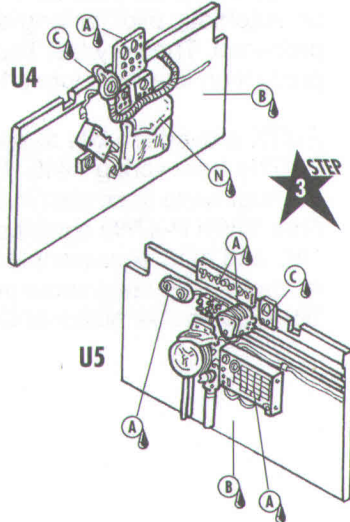
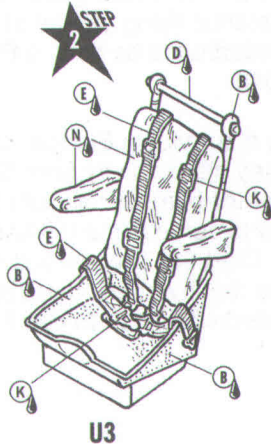
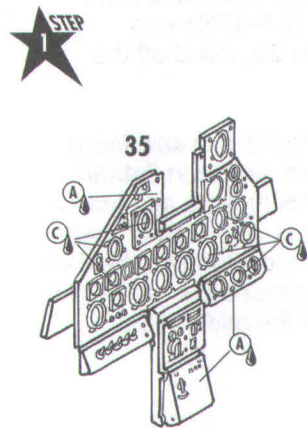
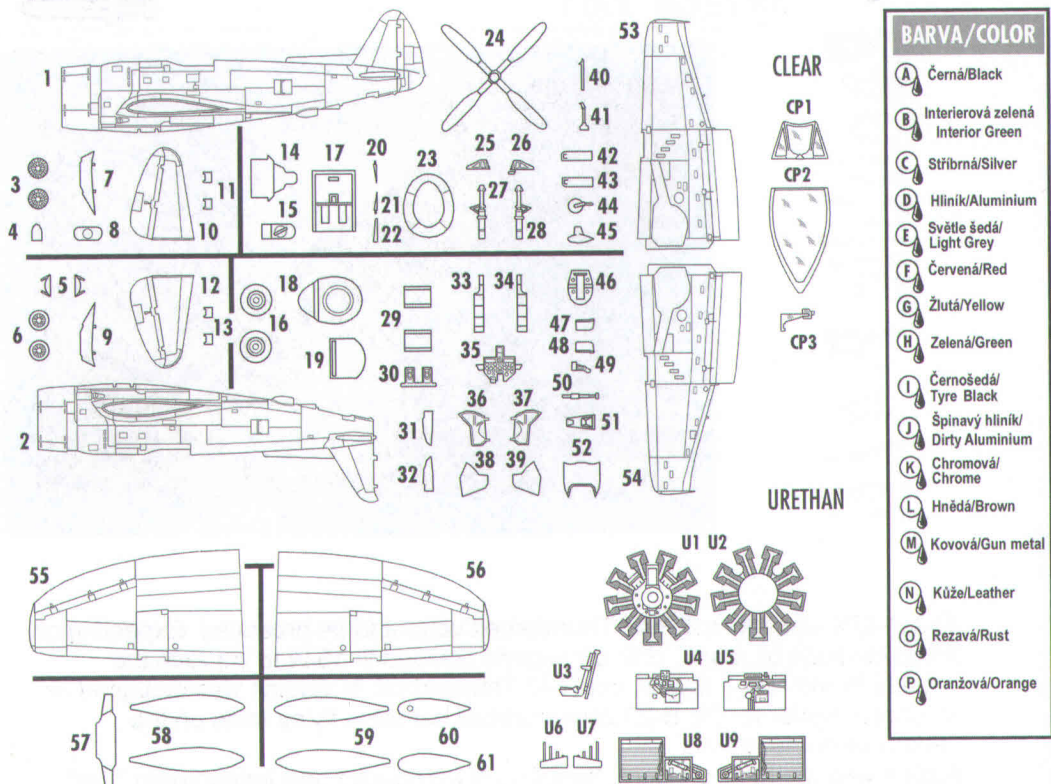

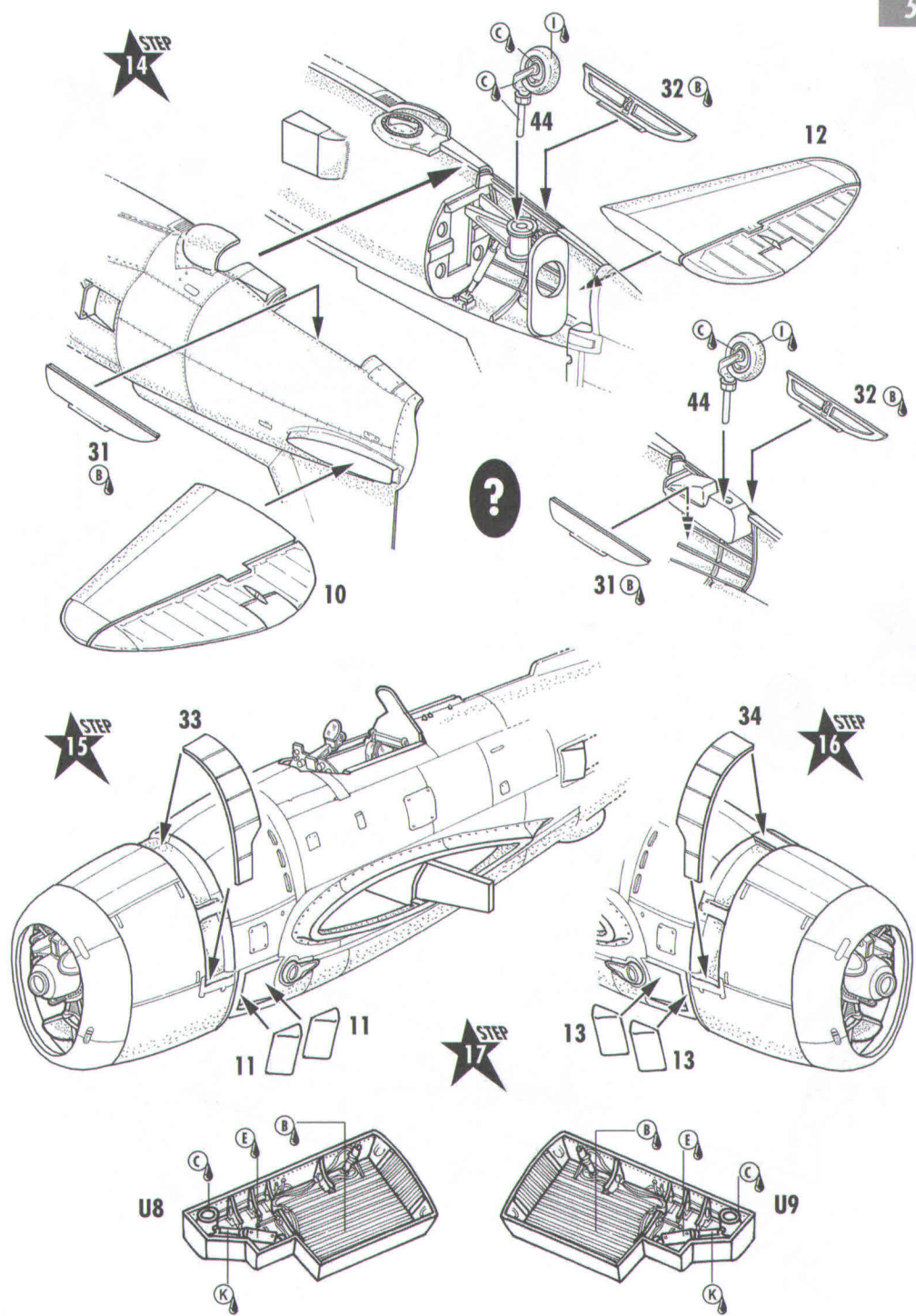
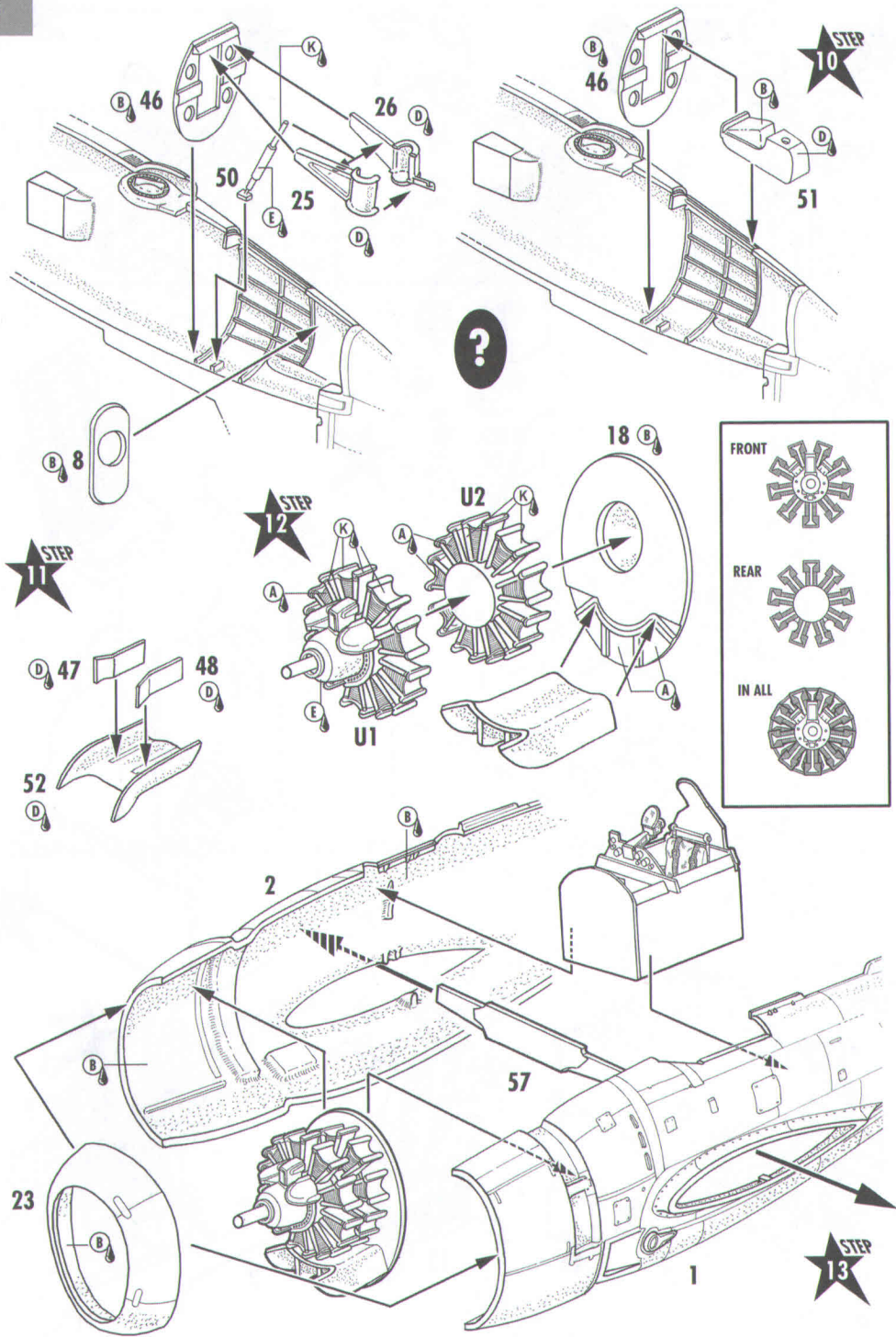

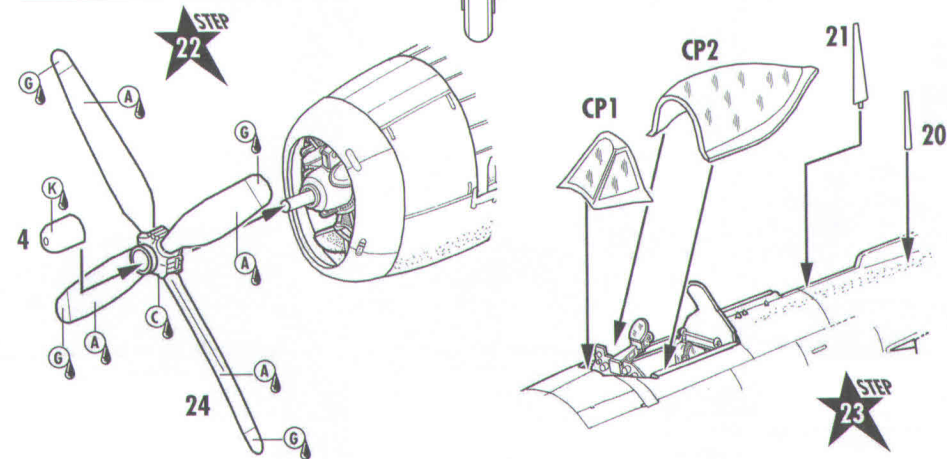
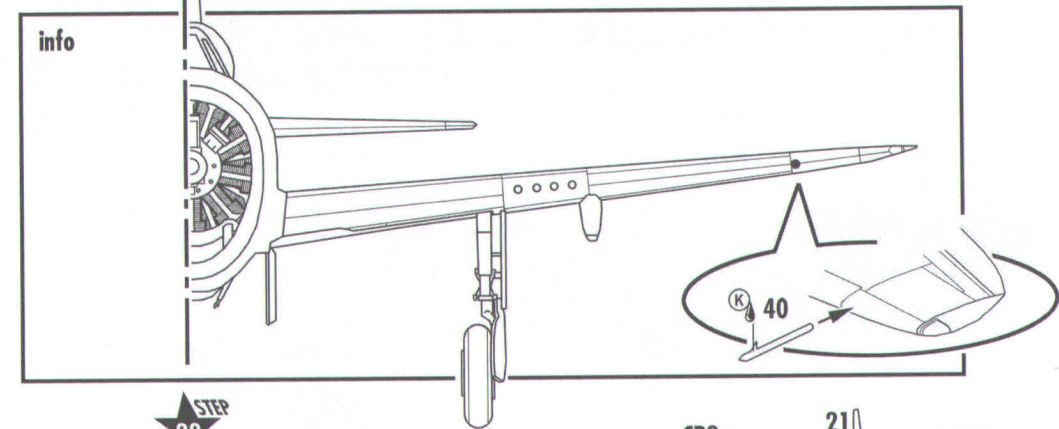
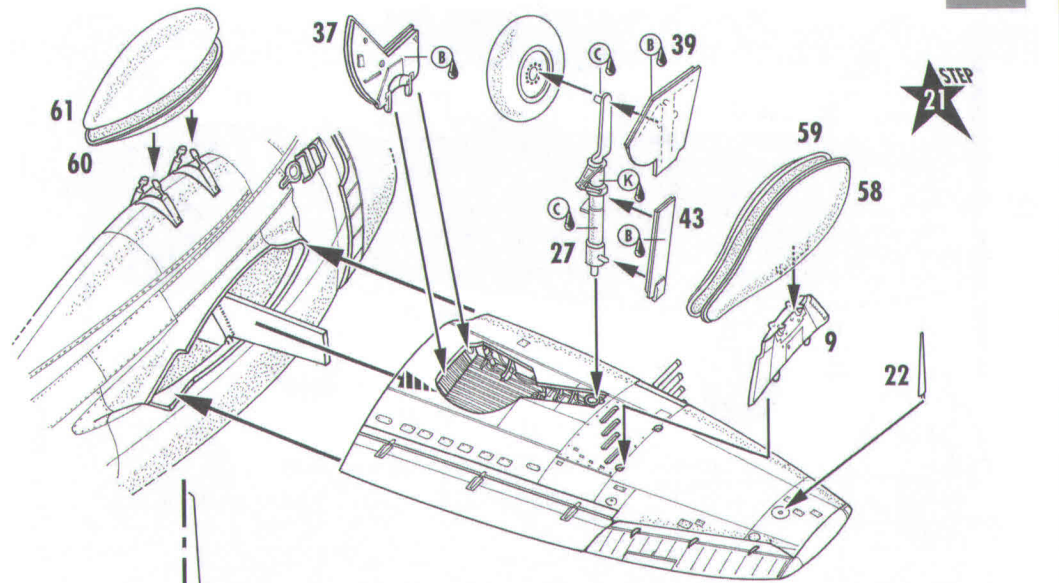
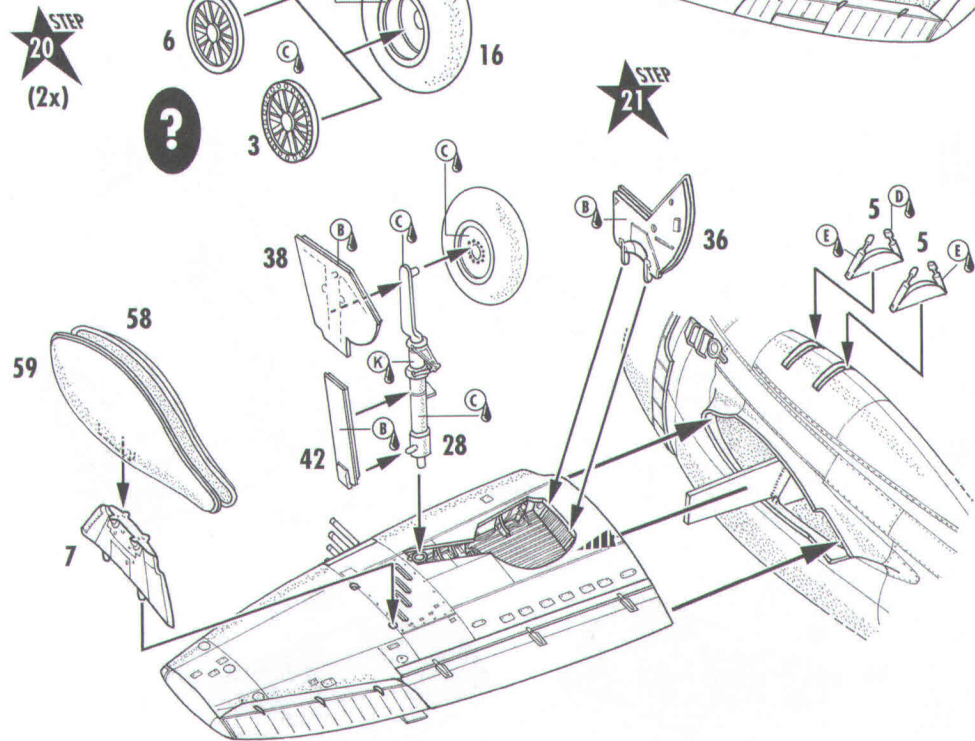
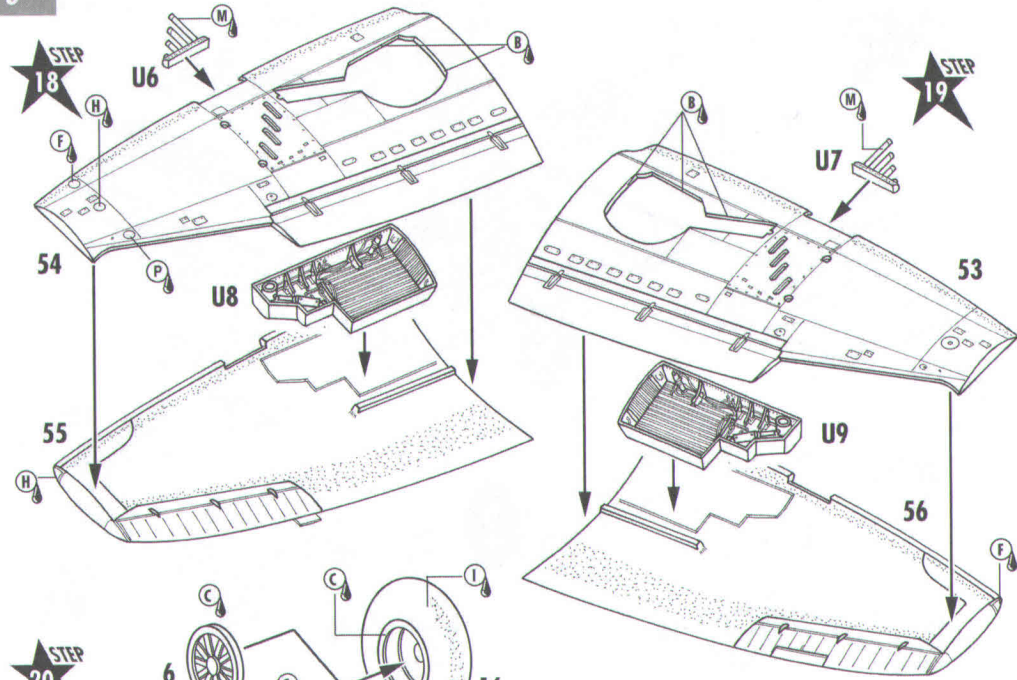

Stencil Placement and Common Data

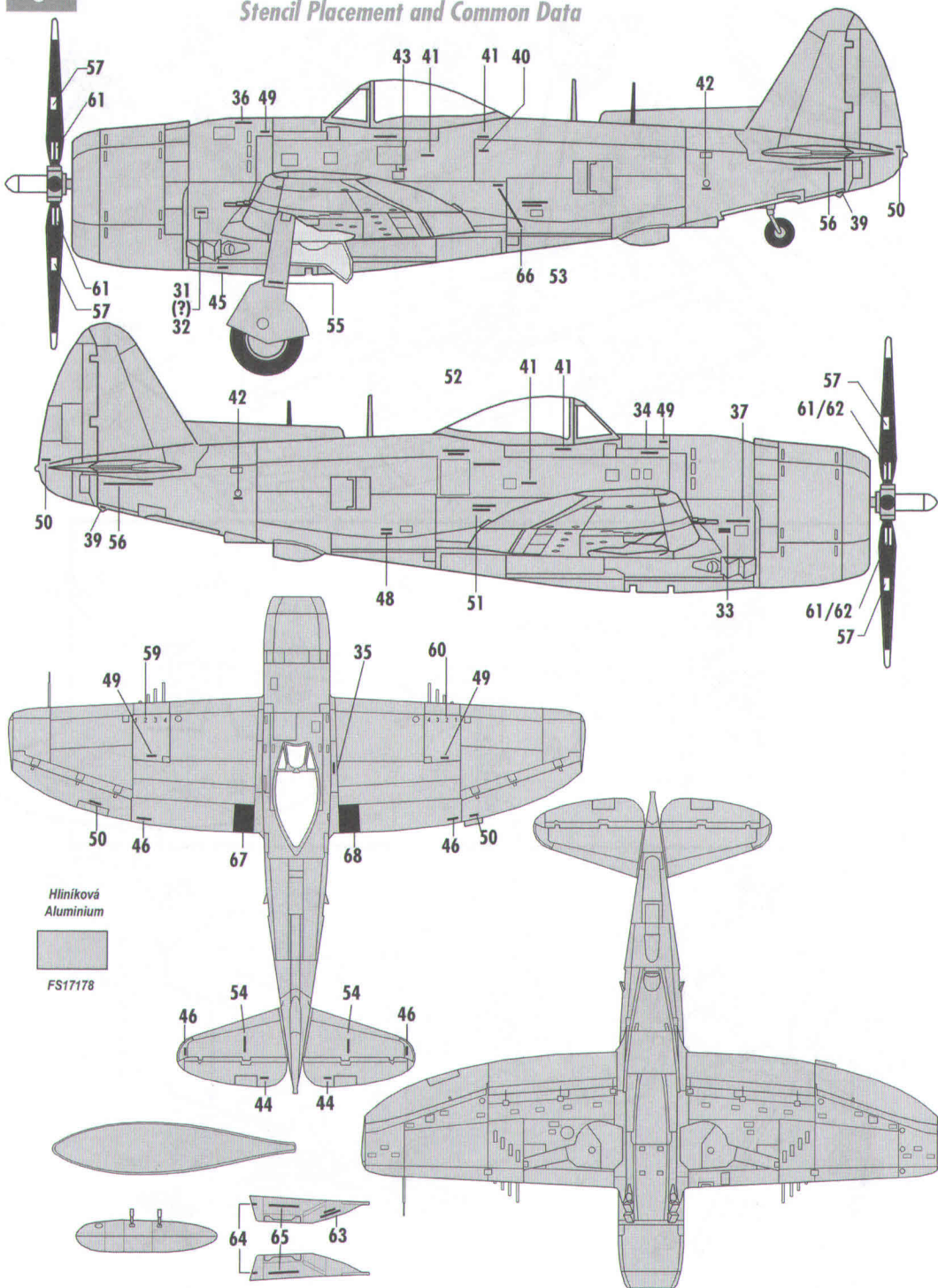

P-47 Thunderbolt

P-47N, of 333rd FS/318th FG (7th AF), flown by Lt. Jack Payne, Ia Shima, Japan, 1945

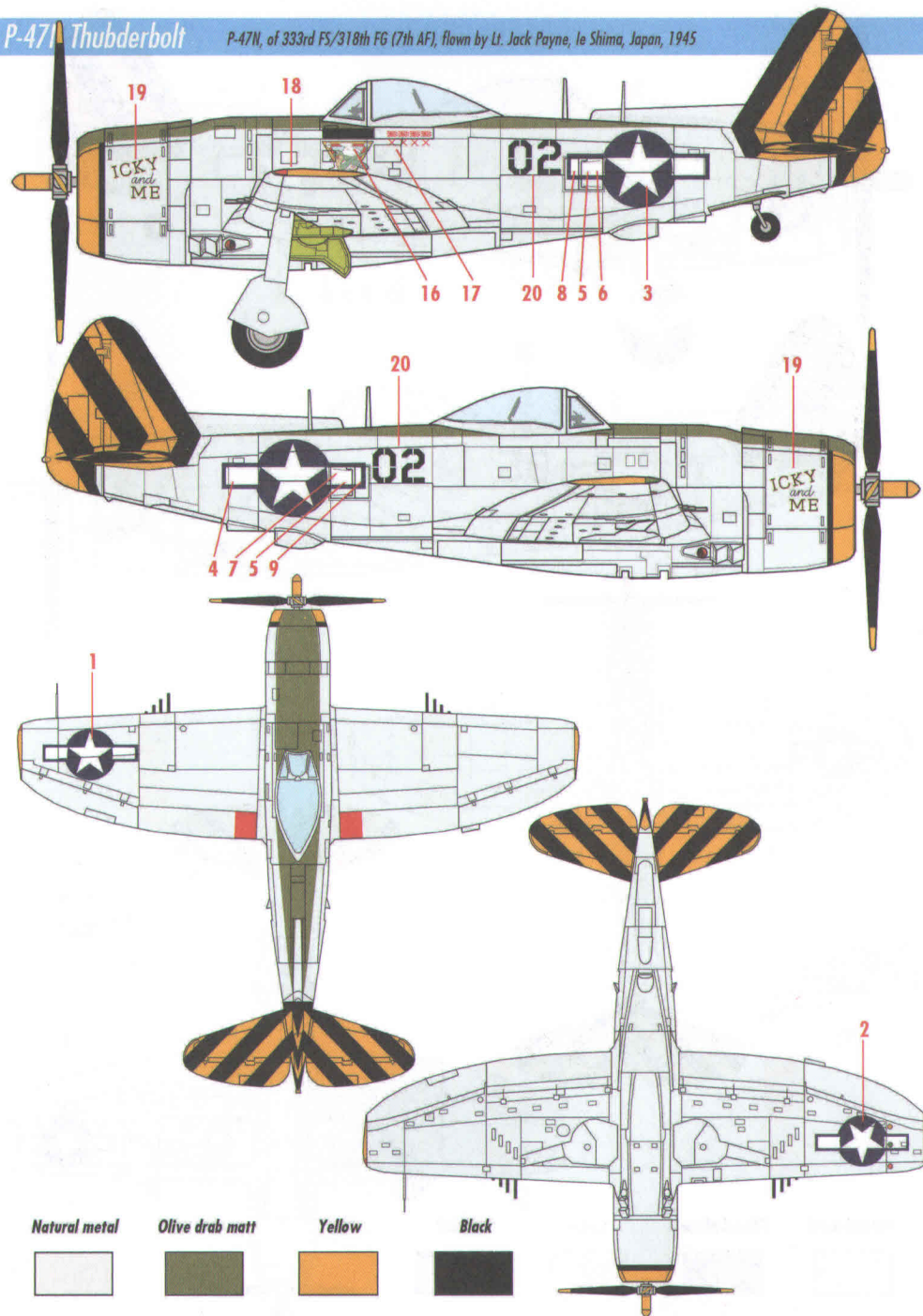

P-47 Thunderbolt

P-47N, 73rd FS/318th FG, Ie Shima, Japan, 1945

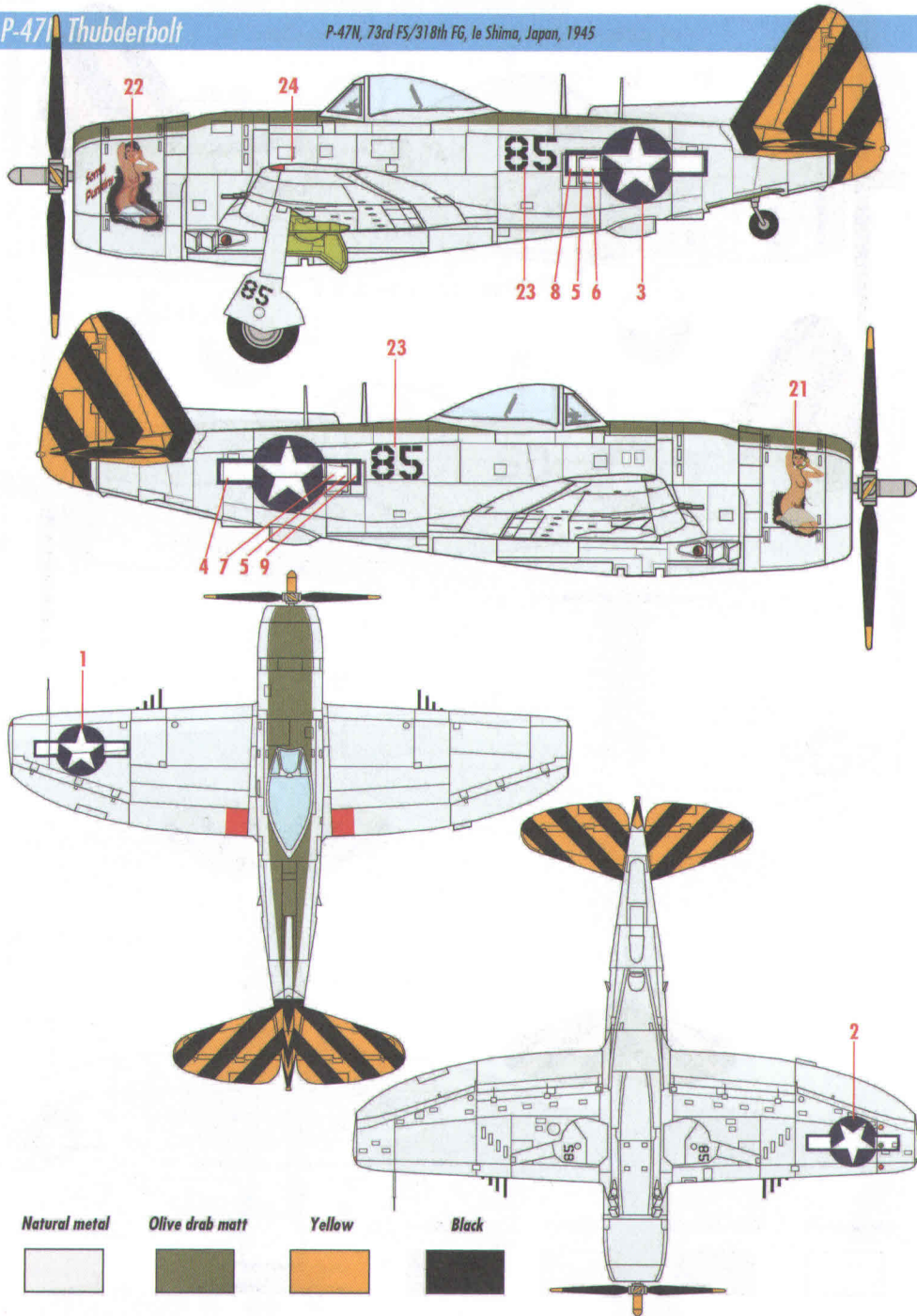

P-47 Thunderbolt

P-47N, 464th FS/507th FG, flown by Lt. Oscar F. Perdomo, Shima, Japan, 1945

