

Wolfpack

www.wolfpack-d.com

# T-38A Talon "NASA"

T-38A 탈론 '나사'



WP10002

1/48 Scale

The T-38 Talon is a supersonic jet trainer by Northrop. It was the world's first supersonic trainer and is also the most produced jet trainers. The United States Air Force is the largest operator of the T-38 series, training missions for USAF pilots, Navy Test pilots and NASA Astronaut. Besides the USAF, the other operators included the ROCAF(Taiwan), Portuguese AF, Turkish AF, ROKAF(South Korea) and Luftwaffe(German).

The NASA(National Aeronautics and Space Administration) started to use T-38A Talon in 1964. They were used by the astronauts flight proficiency training and chase aircraft for Space Shuttle Program and various flight test program.

The NASA has maintained total 32 T-38s now, T-38 Talon fleet has been in service for nearly 50 years with NASA.

T-38 탈론은 미국 노스롭사에서 제작한 초음속 제트훈련기로 등장 당시 세계최초의 초음속 훈련기이다. 초음속 제트훈련기로 생산된 비행기 중 최대인 1,139대가 생산되었다.

T-38A는 T-38 시리즈의 첫번째 양산형으로 작지만 강력한 제너럴 일렉트릭사의 J85-5A 엔진을 장착하여 최고 속도 마하 1.3으로 비행가능하다.

T-38 탈론은 역대 가장 성공한 초음속 제트훈련기로, 1952년 미 공군에서 처음 사용된 이래 50년이 넘는 현재까지 개량을 거듭해 주력 훈련기로 사용중이다. 미 공군 이외에도 미 해군과 미 우주항공국(NASA)의 우주비행사 훈련용으로 운용중이다. 그 밖에 한국, 대만, 터키, 포르투갈 공군이 운용중이거나 운용했다.

나사(NASA : 미 항공우주국)는 T-38 탈론을 1964년부터 사용하여, 우주인의 비행숙달훈련과 스페이스 셔틀의 관측기, 다양한 비행 프로그램의 테스트기로 사용중이다. 현재에도 32대의 T-38 탈론을 개량하여 사용중이며 50년에 가까운 운용역사를 가지고 있다.

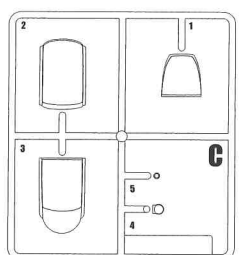
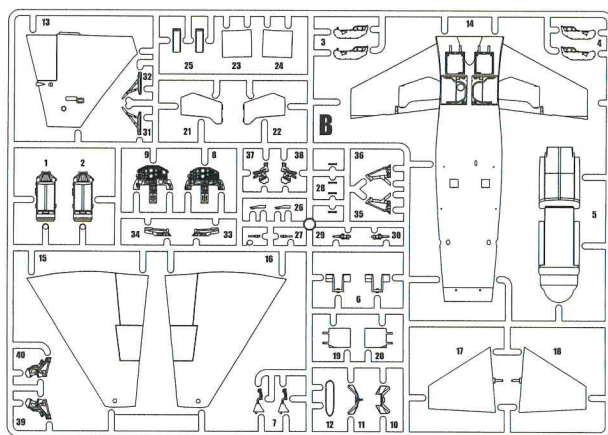
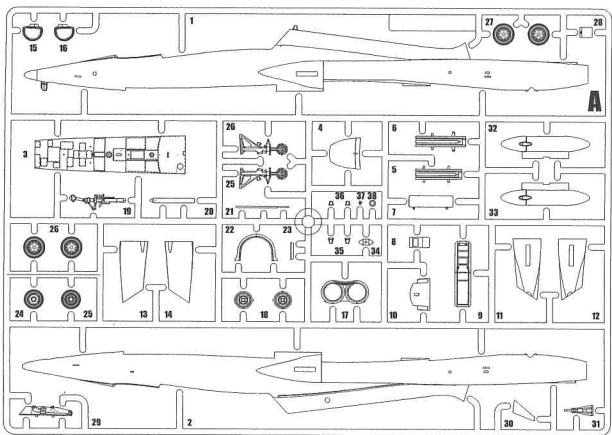

\*R parts : resin wheels

Contains one unassembled model kit only.  
No Paint and Cement in box.  
Kit suitable for Age 14 to Adult.

조립되지 않은 키트가 들어있습니다.  
접착제와 도료는 들어있지 않습니다.  
15세 이상 판매용

Wolfpack-Design Co. Ltd.

F2, 697, I-dong, Sangroku, Ansan-si, Gyeongido, 426-863  
Republic of Korea

울프팩 디자인  
경기도 안산시 상록구 이동 697번지 2층  
우 : 426-863

Parts not for use.  
(불필요부품)

A20, A23, A24, A27,  
A29, A30, B33, B34,  
B42

Printed in Korea



# 1 Ejection seats Assembly (사출좌석 조립)

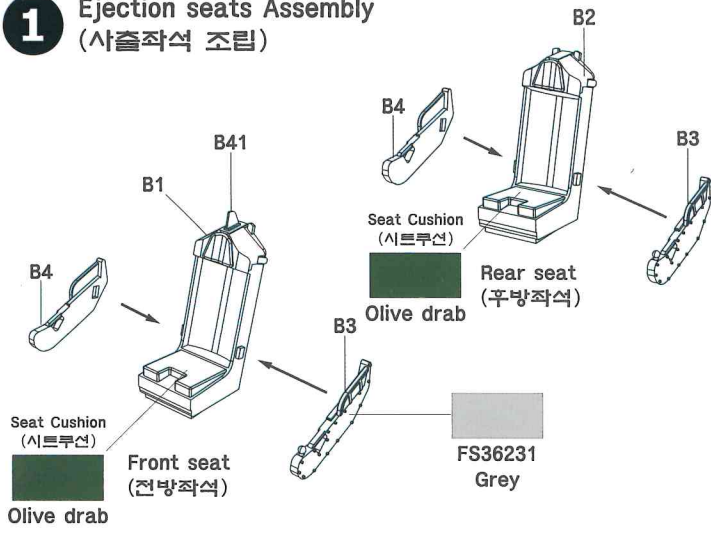

# 2 Front instrument panel & pedals 전방 계기반 및 페달

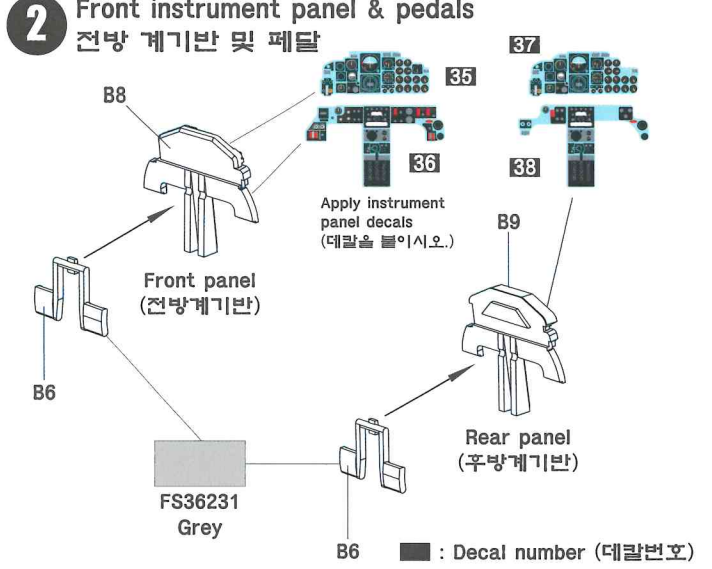

# 3 Cockpit bath-tub (조종석 바닥)

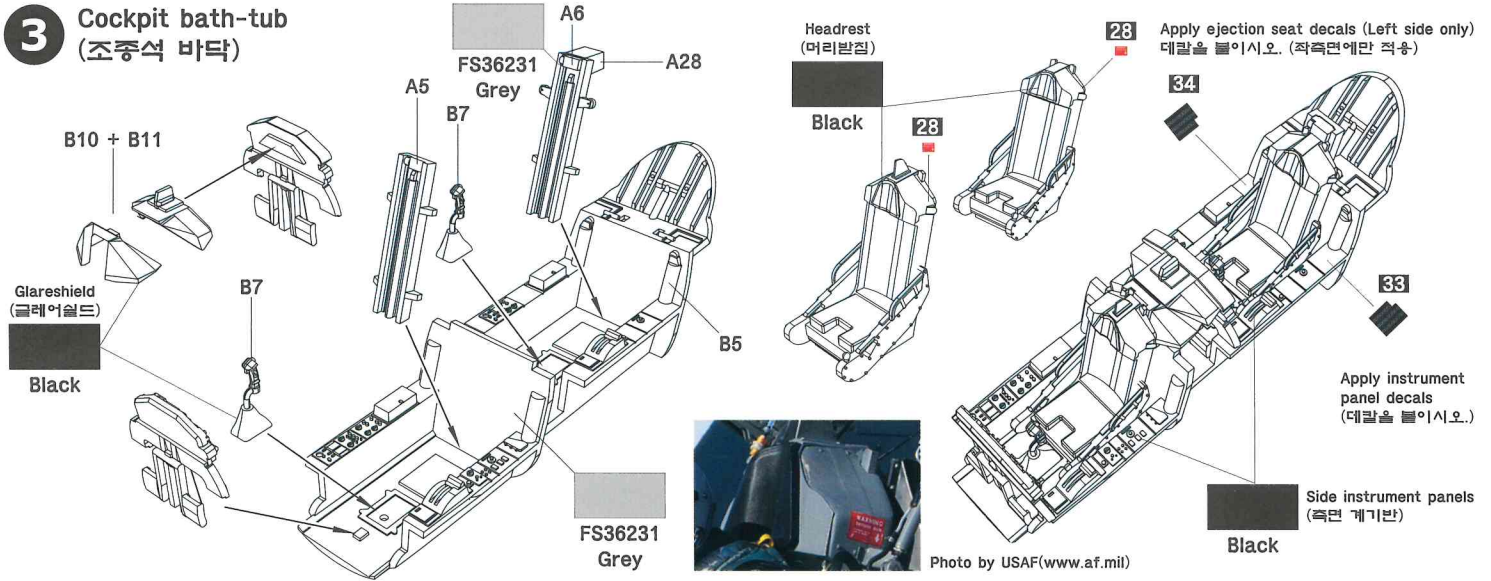

# 4 Fuselage (동체조립)

If you attach a travel pod, please drill hole under bottom fuselage.  
수납용 포드 장착시 동체아면에 구멍을 뚫으십시오.

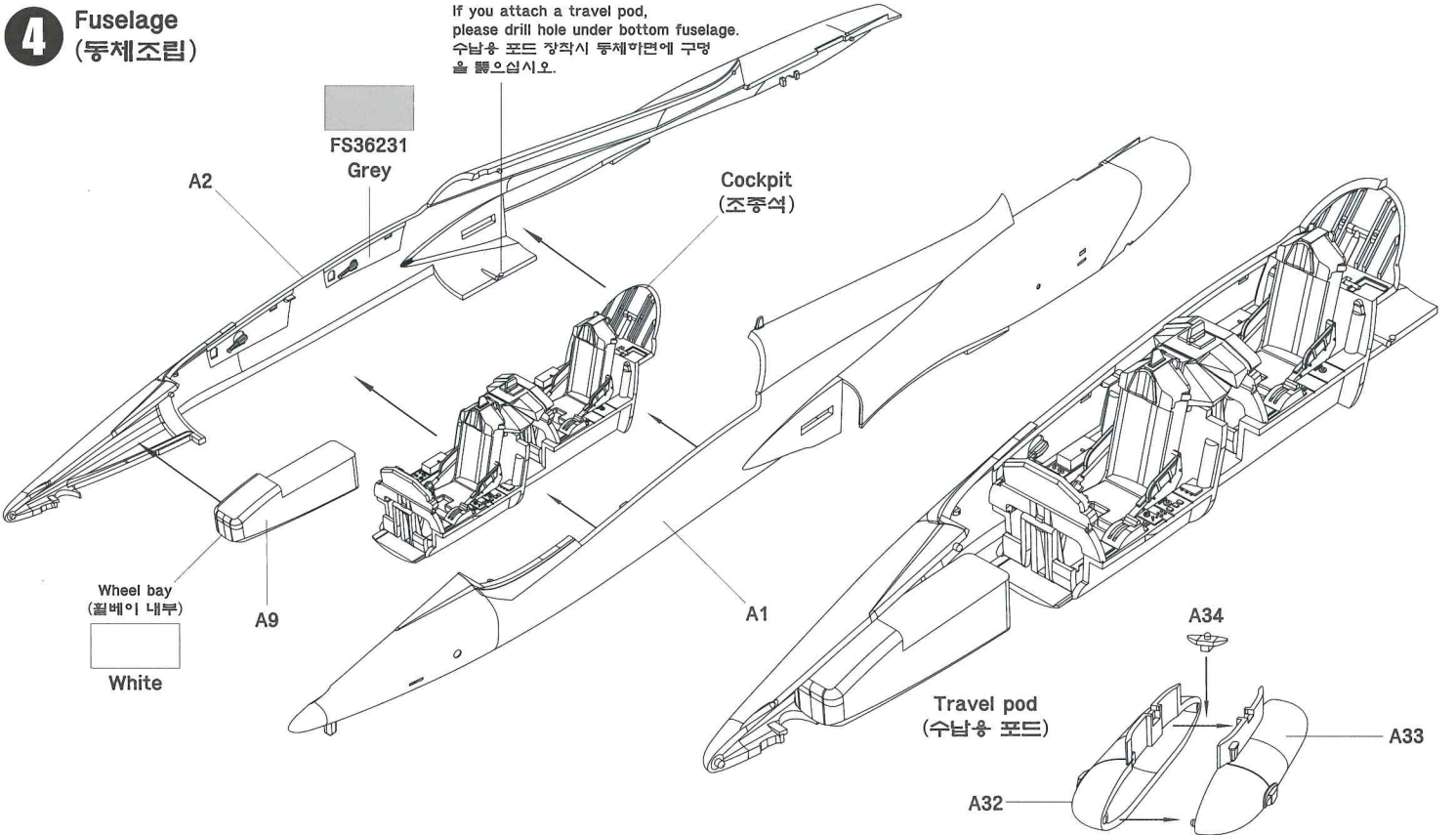

**5** Bottom fuselage  
(하체조립)

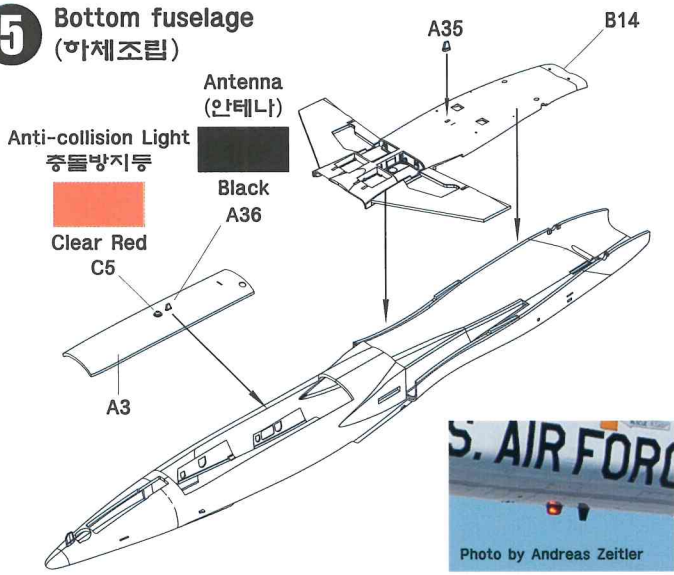

**6** Wing assembly  
(날개조립)

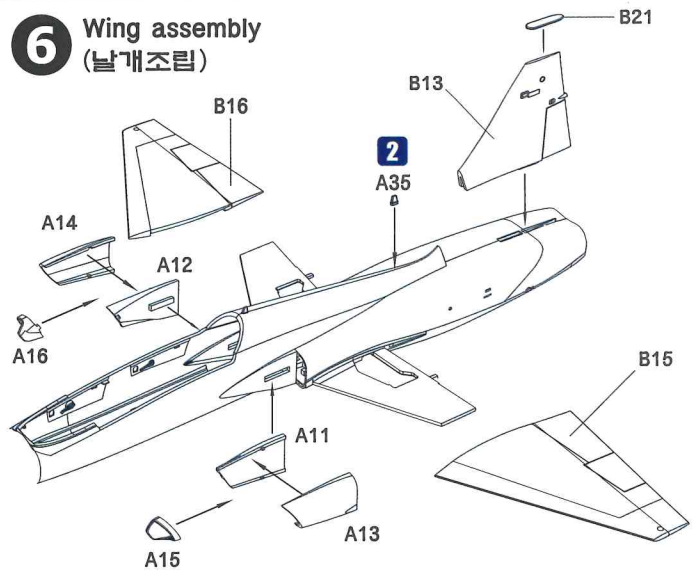

**7** Wing assembly  
(날개조립)

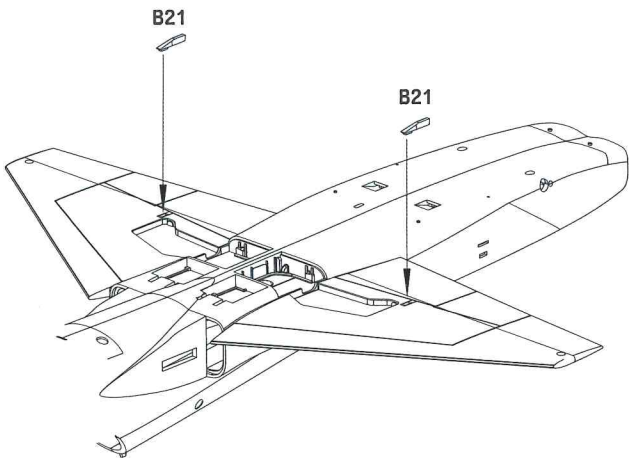

**8** Engine Nozzle  
(엔진노즐 조립)

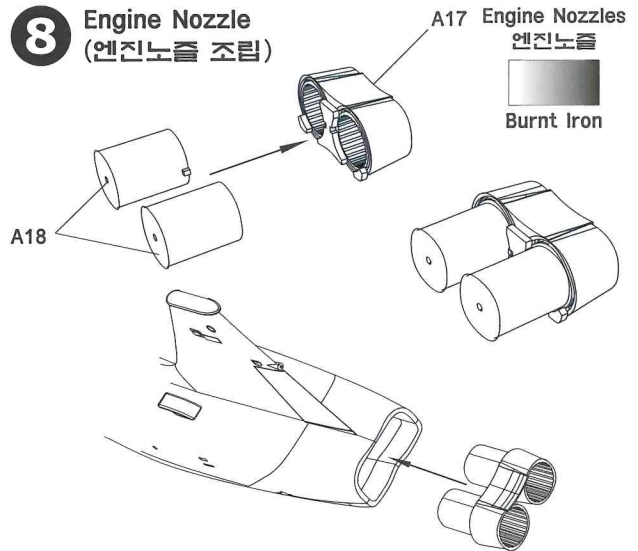

**9** Front Landing gear  
(전방 랜딩기어)

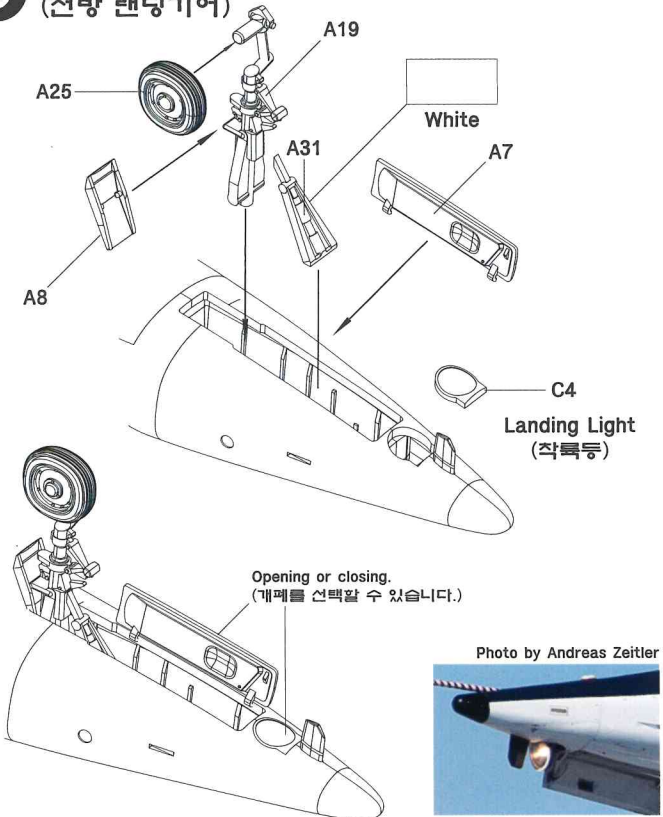

**10** Main Landing gears  
(중재 랜딩기어)

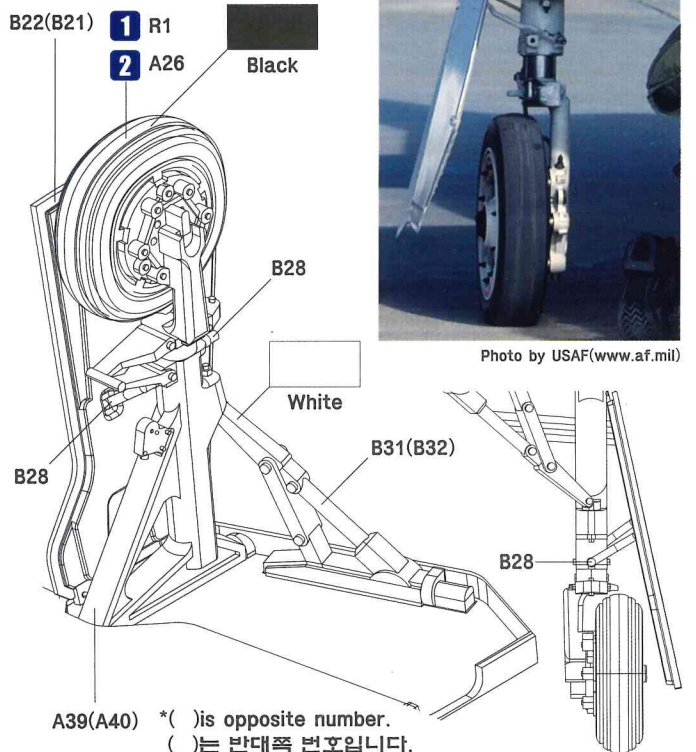



# 11 Air Brake & Rear Wheel bay covers (에어브레이크 및 후방 휠베이 커버)

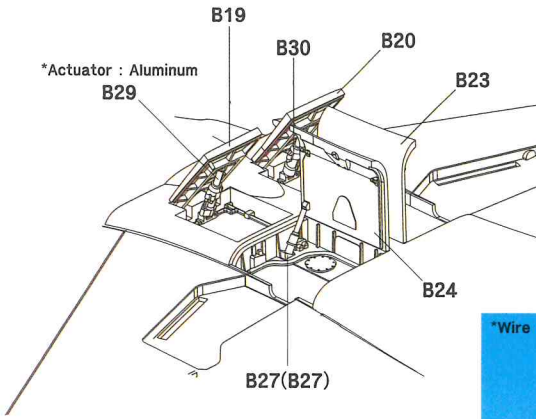

\*Drawing : 1/72nd Scale

# 12 Horizontal tail wings (수평미익)

■ : Decal number (데칼번호)

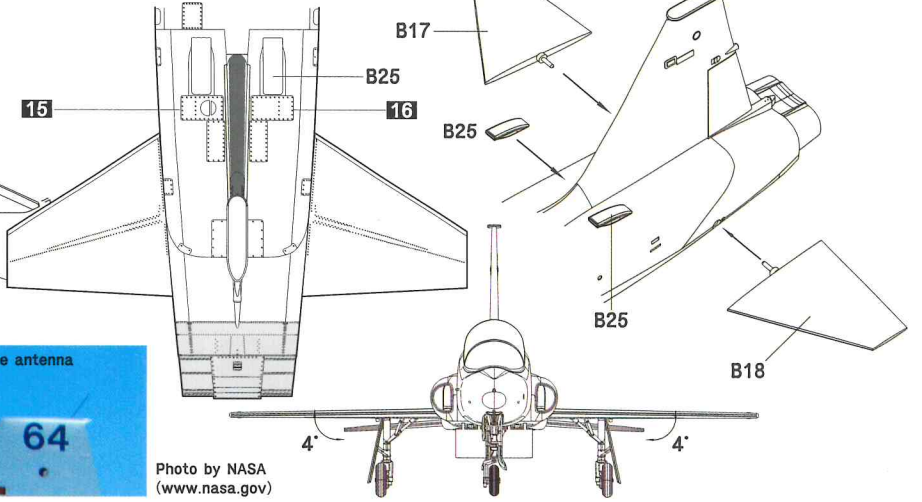

# 13 Canopy open (캐노피 열린 상태)

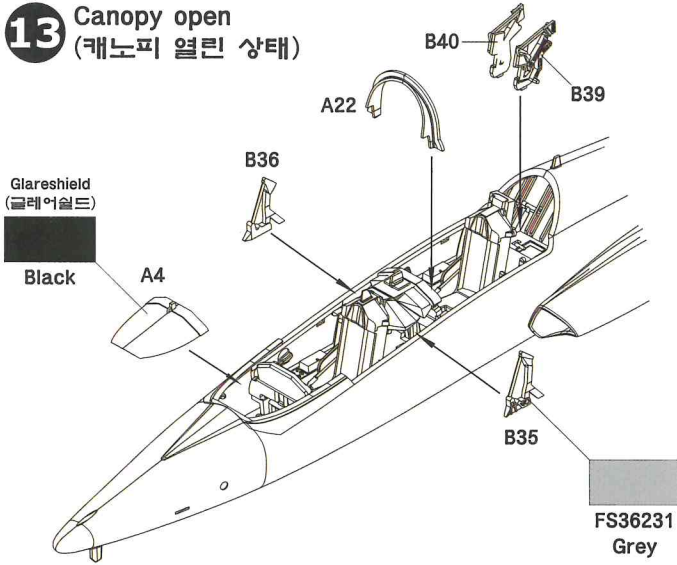

# 14 Canopy closed (캐노피 닫힌 상태)

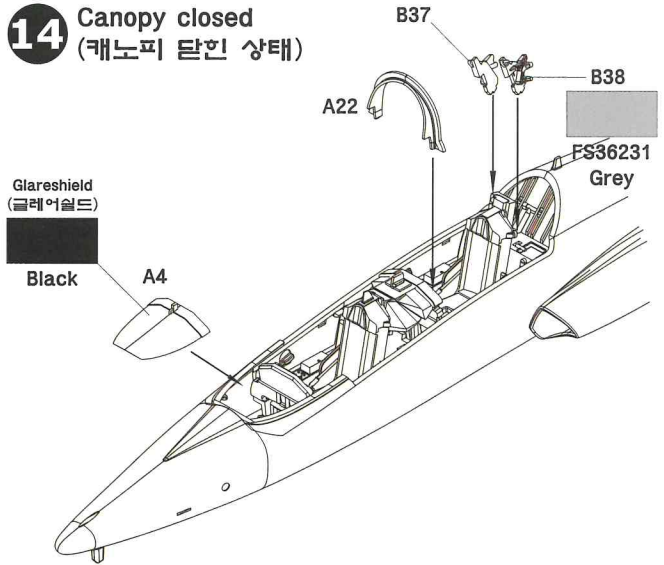

# 15 Final Assembly (최종조립)

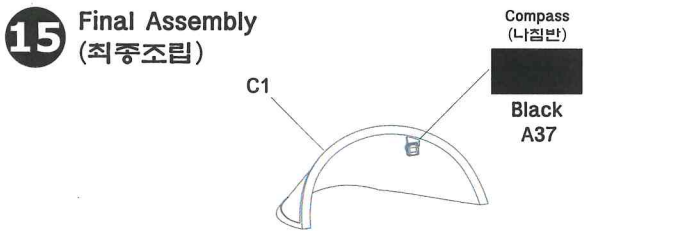

\*Canopy Mask Manual

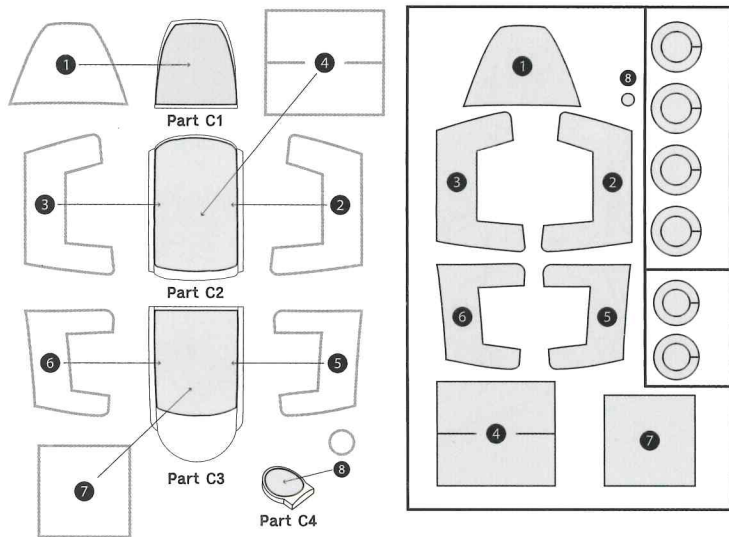

# Canopy open (캐노피 열린 상태)

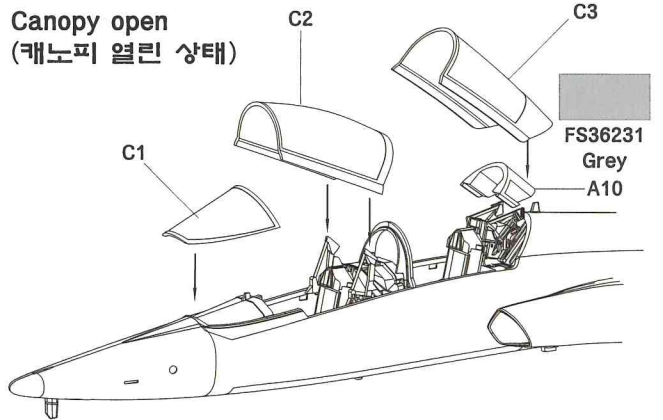

# Canopy closed (캐노피 닫힌 상태)

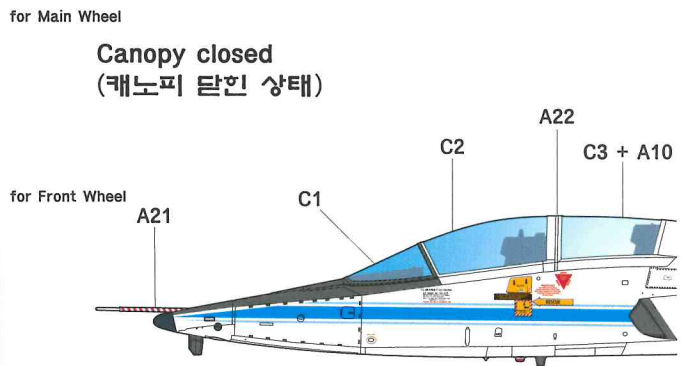

1

T-38A Talon, S/N : N923NA, One of the chase Aircraft for the Space Shuttle 'Columbia' during STS-3 Mission, White Sands Space Harbor, New Mexico, USA, 30th Mar. 1982

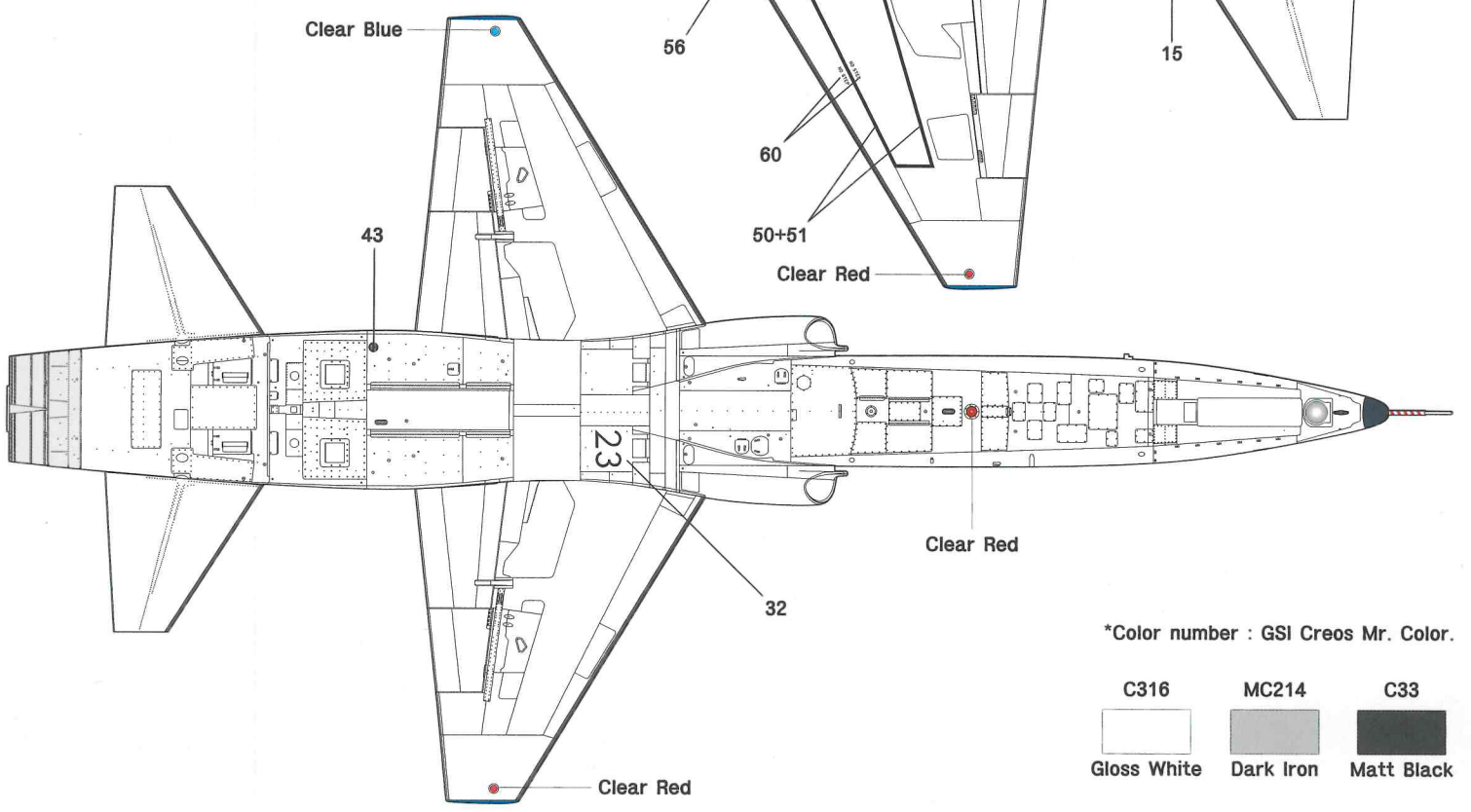
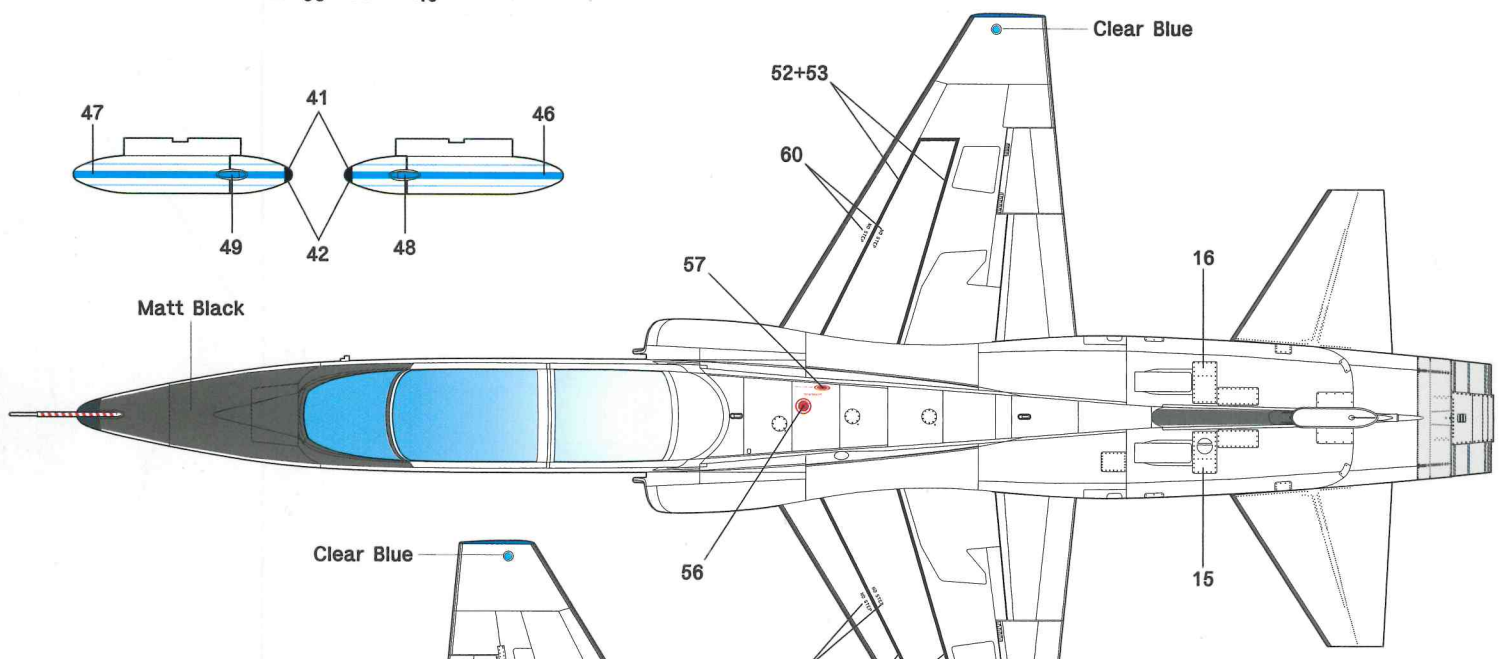
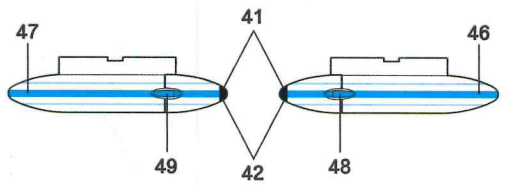
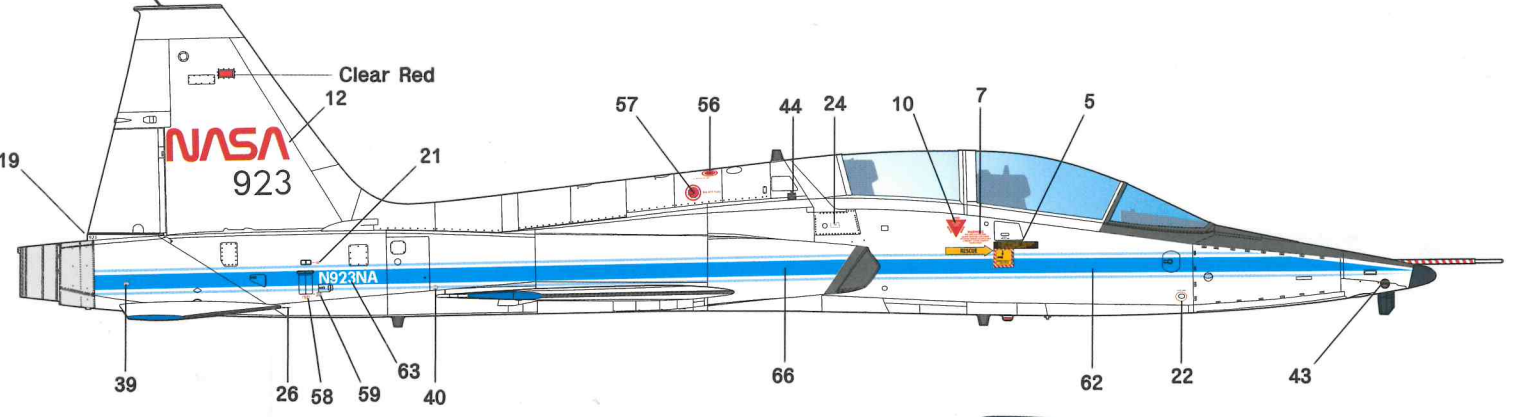
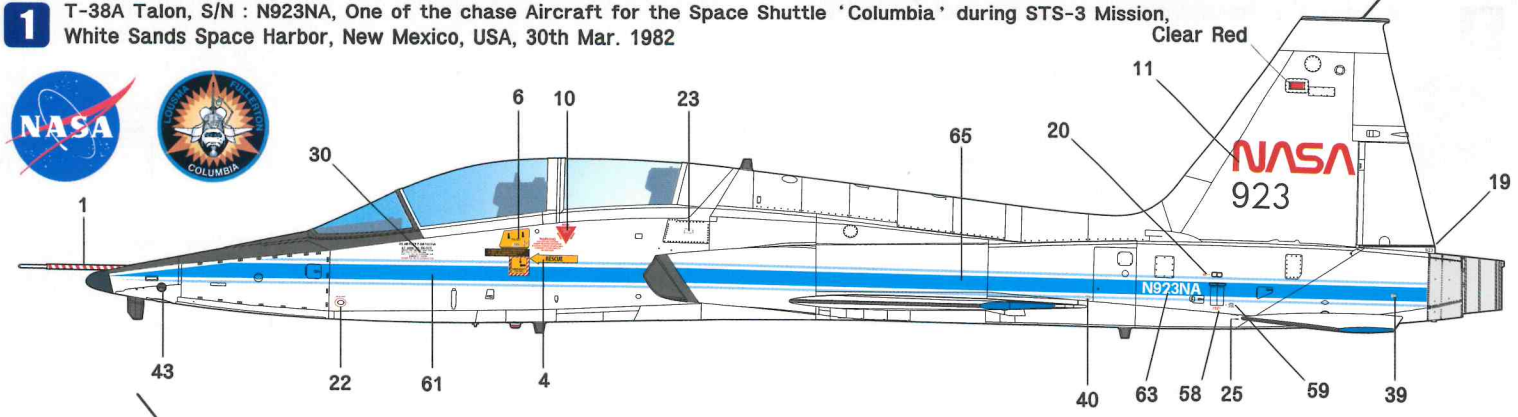

\*Color number : GSI Creos Mr. Color.

C316	MC214	C33
Gloss White	Dark Iron	Matt Black



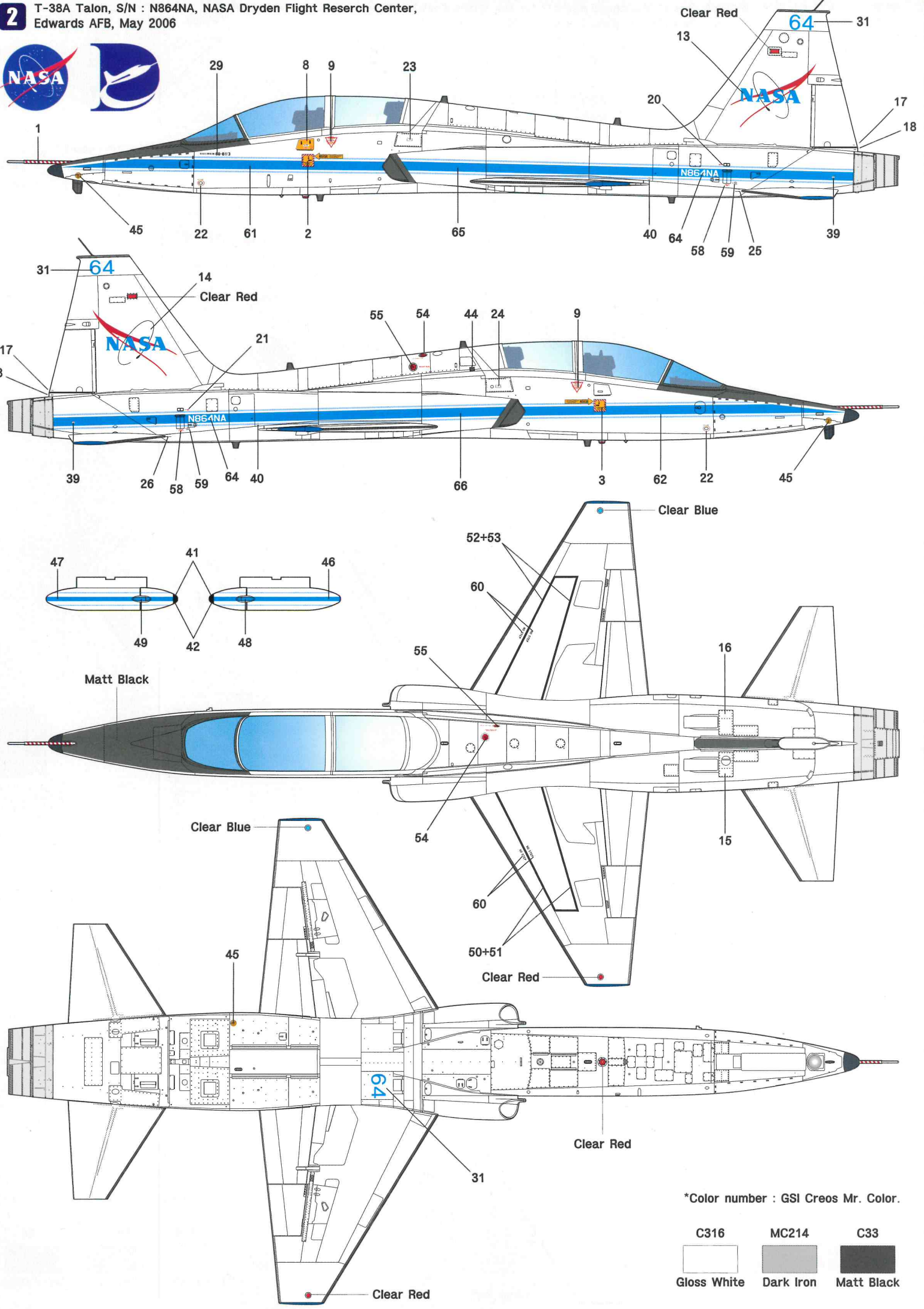

\*Color number : GSI Creos Mr. Color.

C316	MC214	C33
Gloss White	Dark Iron	Matt Black