

SUCHOJ S-37 BERKUT

1/144
SCALE KIT



S-37 베르쿠트 [S-37 BERKUT]

러시아장부 수호이 디자인부서에 의해 여전히 많은 비밀에 싸여 지은 혁신적인 S-37 berkut (Golden Eagle)은 1997년9월25일 모스크바 근처 Zhukovsky에 위치한 Gromov flight test center에서 첫 비행을 했다. 수 년동안 몇몇의 컨셉 모델이 있었고 그중 Forward swept wings (FSW)로 만들어진 것도 있었다. 예로 미국의 Grumman X-29와 독일의 HFB 320 Hansa Jet가 있다. 모든 전진익기 디자인의 기본은 2차대전중 독일의 연구에 근원한다. 2차대전이 끝날때 소련은 전진익기로된 4개 엔진이 달린 제트 폭격기 Junkers Ju287의 prototype를 포획했다. 변형/수정을 통해서 이 기체는 1948년에 EF 131로 비행을 하였고 이후 다시 수정을 통하여 EF140으로 바뀌었다. 러시아는 또한 로켓엔진으로된 전진익기인 Tsybin LL-3를 개발했다. 1993년 TsAGI (Central Institute of Aero and Hydrodynamics)의 발표로 전진익기로 개발된 새로운 수호이 전투기 S-37 (원래는 S-32) 프로젝트의 존재가 처음 알려졌다. S-37은 보여 자기까지 알려진 것이 거의 없고 복잡한 디자인의 많은 요소들이 지금도 비밀로 남아있다. 전진익기는 보통의 후퇴익기 보다 몇몇 이점이 있다. 특히 천공속 비행의 공중전시 즉 날개의 비틀거림이 현저히 줄어 조종사의 조작이 용이하며 이착륙 수행이 모두 다 나아질 수 있다. Berkut prototype은 Sukhoi에 의해 투자되었으며 두개의 Aviadvigatel D-30F6 터보제트엔진을 쓰는 Su.27K의 하부구조를 포함하여 기존의 다른 타입의 기체 부품들이 사용되었다. 자체한 성능에 대하여는 알려지지 않았으나 해수면에서의 최고속도는 1,400km/h (870mph)정도 고도비행시는 2,200km/h(1,367mph)로 추정된다. S-37 Berkut는 새로운 혁신의 증명이나 향후 개발은 자금부족과 전략변화등으로 불확실하다. 날개길이 16.70미터, 동체길이 22.60미터, 높이 6.40미터.

Still shrouded in much secrecy following its development by the Russian Sukhoi design bureau, the revolutionary S-37 berkut (Golden Eagle) first flew on 25 September 1997 from the Gromov flight test centre at Zhukovsky, near Moscow. For many years, there have been several concept models and some aircraft built with forward swept wings (FSW) - examples being the experimental American Grumman X-29 and the production German HFB 320 Hansa Jet - the basis for all of these designs originating with German research during World War Two. At the end of the war the Soviet captured the prototype Junkers Ju287, a four-engined jet bomber with FSW. Following modification, this aircraft flew in 1948 as the EF 131, and was later modified into the EF 140 - the Russians also developed the Tsybin LL-3 rocket powered FSW project. News of the existence of the S-37 (originally S-32) project first became known in 1993 with an announcement design with FSW was being developed for Sukhoi - little more was known until the S-37 appeared and even now many details of its complex design remain secret. The FSW has several advantages over the conventional swept wing, especially at transonic speeds, for aircraft operating in the air combat role - wing torsional stiffness is markedly increased especially with the use of composite materials, while drag factors, manoeuvrability, landing and take off performances can all be improved. The berkut prototype was founded by Sukhoi and makes use of several of their existing component parts from other types, including the undercarriage of the Su.27K - it is powered by two Aviadvigatel D-30F6 turbojets each rated at 93.2kn (9 508kg/20,956 lbs) dry thrust and 152kn (15,503kg/34,177) with afterburners. Detailed performance figures have not been released but maximum speed is estimated to be about 1,400km/h (870mph) at sea level and 2,200 km/h (1,367mph) at altitude. The S-37 Berkut is a proof-of-concept prototype and its future development status is presently uncertain - two factors which may affect this are a possible lack of funding and major differences between the interested civil and military procurement authorities. Wing span : 16.70m (54ft 10in.) Length : 22.60m (74ft 2.6in.) Height : 6.40m (21ft).

Used Symbols



Glue



Don't glue



Optional



Detach with knife



Used color



Soak and apply decals

1 

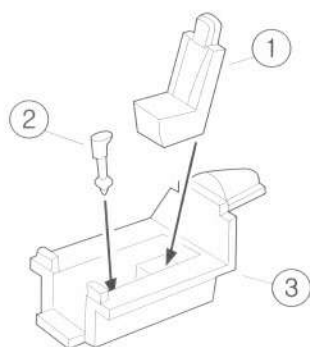

2  

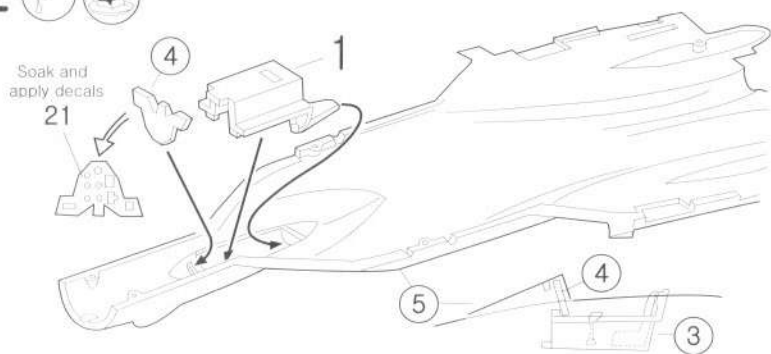

3 

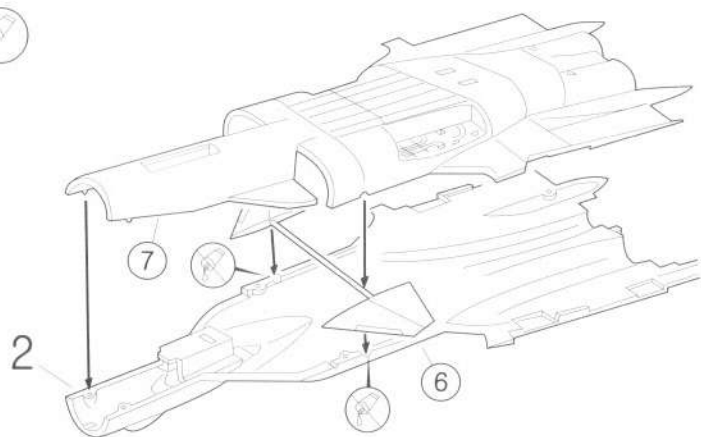

4

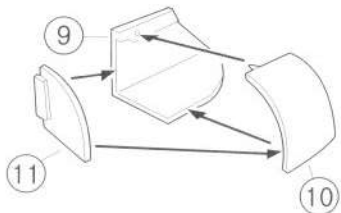

5

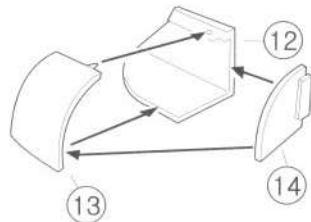

6

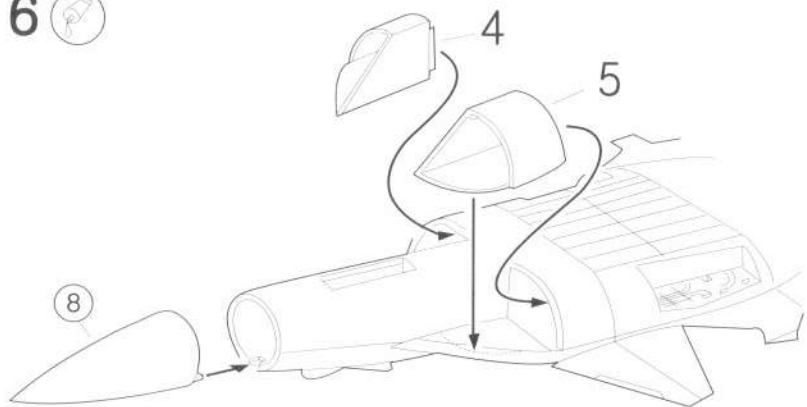

7

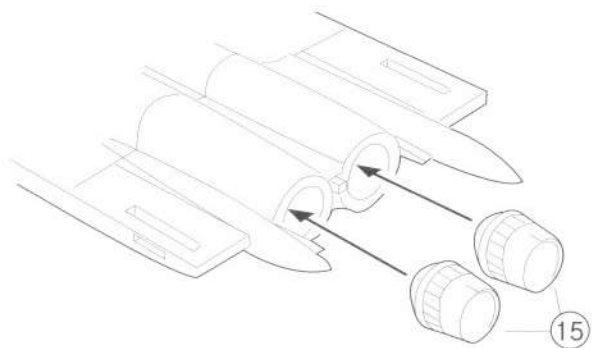

8

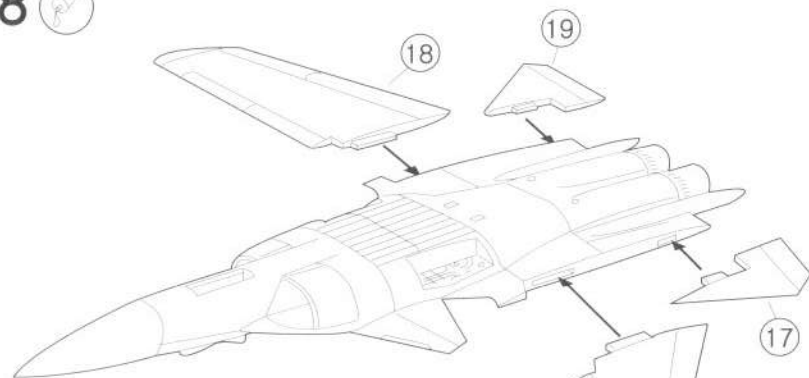

9

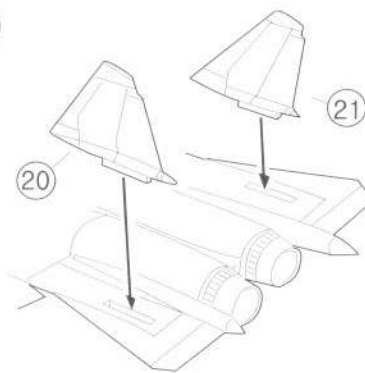

10



11

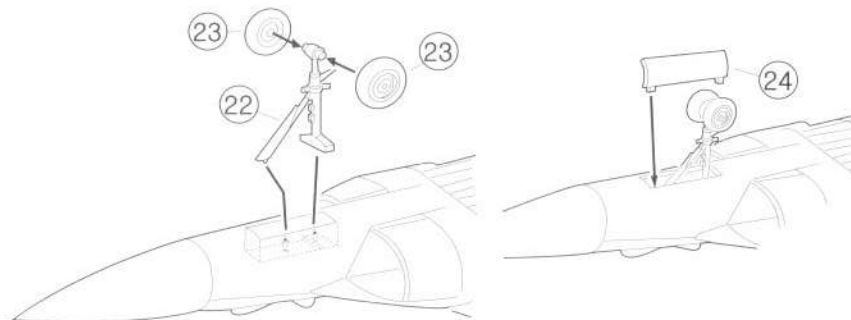

12 

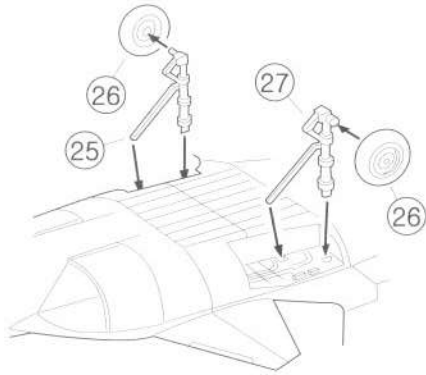

13 

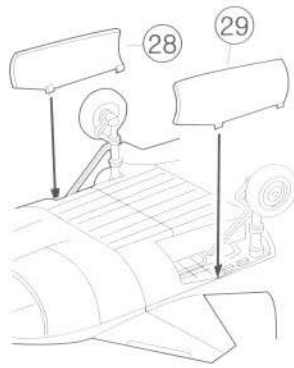

14  

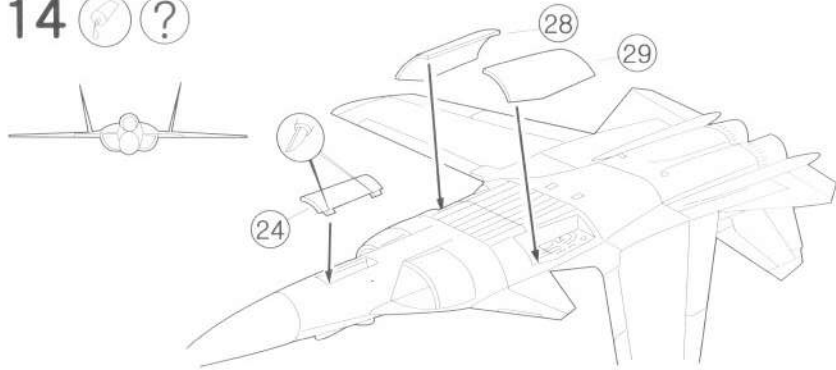

15 

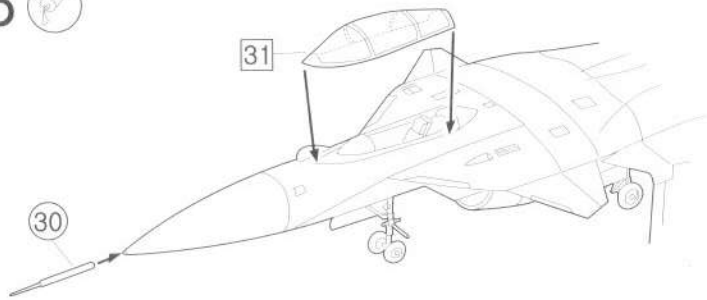

SUCHOJ S-37 BERKUT 1/144

SCALE KIT

[painting & Decal placement guide]



S-37 BERKUT "Ok6 Suchoj"

 Black (80%) + Blue (20%)

 Metallic

 Aero White

 1/144 S-37 BERKUT
© 2001 Product under license by Axe Corporation, Korea.

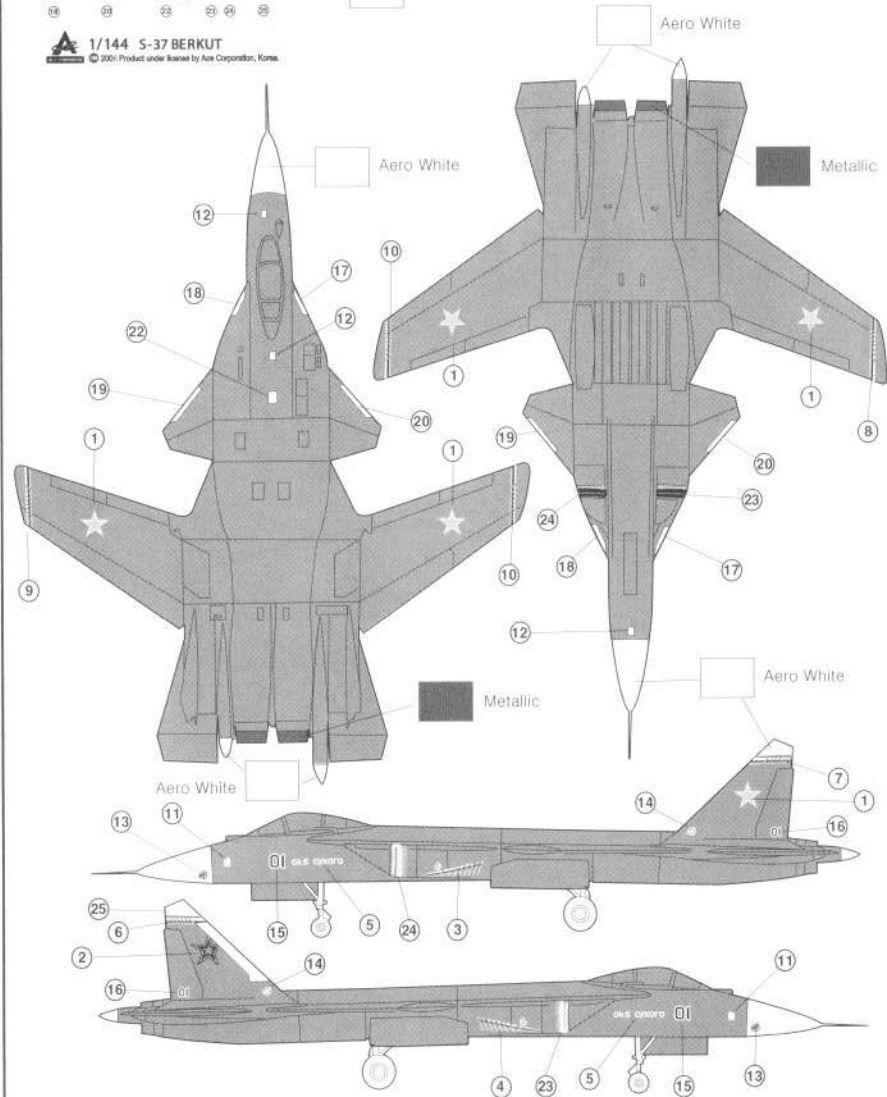



1/144 S-37 BERKUT

© 2006 Product under license by Ace Corporation, Korea.