



# Eurofighter TYPHOON & Engine

A 04783-0389

© 2009 BY REVELL GmbH & CO. KG

PRINTED IN GERMANY

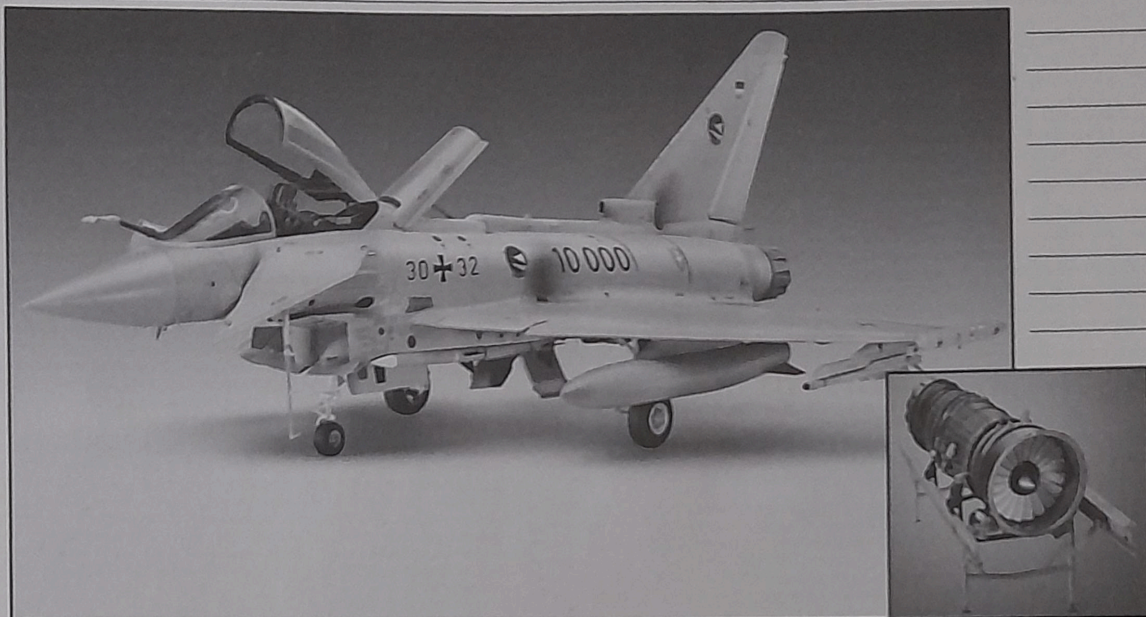

## Eurofighter TYPHOON & Engine

Der Eurofighter ist das derzeit überragende Hochleistungs-Mehrrollen-Kampfflugzeug der neuesten Generation. Mit einer Höchstgeschwindigkeit von Mach 2,0+ beherrscht der Eurofighter sowohl den Luftfern- und -nahkampf als auch den Luft-Boden-Einsatz. Die Maschine ist dank ihrer geringen Radarsignatur und der Verwendung nichtmetallischer Werkstoffe vom Gegner kaum zu entdecken. Der Eurofighter vereint nicht nur innovative und fortschrittliche Technologien, sondern ist auch ein internationales Programm von großer politischer und wirtschaftlicher Bedeutung. 707 Flugzeuge sind bislang geordert worden.

An dem Gemeinschaftsprojekt beteiligten sich vier europäische Länder: Deutschland, Großbritannien, Italien und Spanien. Sie übertrugen die Geschäftsführung auf das NATO European Fighter Aircraft Management Team (NEFMA) die zusammen mit dem Eurojet EJ200 Konsortium - für die Triebwerksentwicklung- ein gemeinsames Jagdflugzeug entwickelten. Mit der gemeinsamen Anschaffung ergab sich damit auch eine Kostensenkung durch eine Vereinfachung in der Wartung und im Einsatz. Auf Grund seiner besonderen Auslegung unter Verwendung von „Stealth-Technologien“ und einer überwiegenden Benutzung von Kohlefaserverbundwerkstoffen hat der Eurofighter eine sehr geringe Radar-Rückstrahlfläche. Durch die in besonderem Maße angewendeten neuen Technologien ist der Eurofighter jedoch aerodynamisch instabil und die volle Kontrolle wird nur durch ein vierfach ausgelegtes digitales Flugkontroll-System erreicht. Die dabei erzeugte künstliche Stabilität befähigt den Eurofighter damit aber auch zu außergewöhnlichen Flugeigenschaften, die sich durch extrem hohe Wendigkeit dokumentieren. Mit seinen für Piloten optimalen Sichtverhältnissen und einem Helm mit eingebautem Display und einer zusätzlichen direkten Sprachsteuerung für Befehle kann sich der Pilot direkter auf seine eigentlichen Aufgaben konzentrieren.

Mit der Möglichkeit an 13 Außenstationen unterschiedlichste Waffen einzusetzen erfüllt der Eurofighter alle Anforderungen, die an ein modernes Kampfflugzeug gestellt werden. Das multi-funktionale Langstrecken-Suchradar des Eurofighters kann mehrere Ziele gleichzeitig aufnehmen und den Waffeneinsatz optimieren. Mit den AIM-120 AMRAAM und der britischen Meteor-Rakete können so auch Ziele außerhalb der Sichtweite des Piloten bekämpft werden. Für den Kurz- und Mittelstreckenbereich stehen als Standardbewaffnung neben der bekannten AIM-9L Sidewinder auch noch die modernen Typen IRIS-T und die AIM-132 ASRAAM zur Verfügung.

### Technische Daten

Länge	15,96 m
Spannweite	10,95 m
Höhe	5,28 m
Triebwerk	2x Eurojet EJ-200-3A
Leistung	11.000 kp
Leergewicht	10.995 kp
Startgewicht max.	23.000kg
Zuladung	6500 bis 8000 kg
Höchstgeschwindigkeit	Mach 2,0
Höchstgeschwindigkeit in geringen Höhen	1390 km/h
Steigzeit auf 10 700 m	2,5 Minuten
Reichweite in Bodennähe	650 km
Reichweite in 10 500 m	1390 km
Bewaffnung:	1 x Mauser-Kanone Bk-27, Kaliber 27 mm
Besatzung	1 Mann

## Eurofighter TYPHOON & Engine

The Eurofighter is currently the superior new generation high performance multi-role fighter aircraft. With a top speed in excess of Mach 2, the Eurofighter dominates both long and short range air-to-air combat and also air-to-ground attack. To an enemy the aircraft is almost imperceptible due to its small radar signature and the use of non-metallic materials. The Eurofighter not only combines innovative and advanced technologies, but is also an international program of great political and economic significance. Seven hundred and seven aircraft have been ordered so far.

The four participating European countries are: Germany, Great Britain, Italy and Spain. Project management was transferred to the NATO European Fighter Aircraft Management Team (NEFMA) who together with the Eurojet EJ200 consortium - responsible for engine development - jointly developed the fighter aircraft. Joint acquisition enabled a reduction in costs resulting from the simplification of servicing and deployment. The Eurofighter has a very small radar reflecting area due to its special construction using „Stealth Technology“ and an overwhelmingly large proportion of carbon-fibre materials. The Eurofighter is however aerodynamically unstable due to the host of new technological measures incorporated and full control of the aircraft can only be achieved through the use of a quadruple Digital Flight Control System. The artificially generated stability enables the Eurofighter to achieve exceptional flight characteristics which are documented by the aircraft's extremely high manoeuvrability. With its optimum field of view, a helmet with integrated display and an additional direct voice control system the pilot is able to concentrate fully on his primary task. With the option to field a large variety of weapons on its thirteen external stations, the Eurofighter fulfils all the demands placed on a modern Combat Aircraft. The Eurofighter's multi-functional long-range search radar can simultaneously acquire multiple targets whilst optimising the use of its weapons. Targets beyond the visual range of the pilot can be engaged using the AIM-120 AMRAAM and the British Meteor Missile. As well as the well known AIM-9L Sidewinder, the standard armament of the Eurofighter also contains the modern IRIS-T and AIM-132 ASRAAM for use at short and medium ranges.

### Technical Data

Length:	15,96m (52ft 4ins)
Wingspan:	10,95m (35ft 11ins)
Height:	5,28m (17ft 4ins)
Engines:	2x Eurojet EJ-200-3A
Power:	11000kp
Empty Weight:	10995kg (24244lbs)
Max Take-off Weight:	23000kg (50715lbs)
Payload:	6500 to 8000kg (14332 to 17640lbs)
Maximum Speed:	Mach 2,0
Maximum Speed at Low Level:	1390 km/h (863mph)
Time to Climb to 10700 m (35000ft):	2,5 Minutes
Range at Low Level:	650km (403miles)
Range at 10500 m (34440ft):	1390km (863miles)
Armament:	1 x Bk-27 Calibre 27mm Mauser-Canon
Crew:	1

Form hergestellt und in Eigentum von Revell GmbH & Co. KG. Widerrechtliche Nachahmungen werden gerichtlich verfolgt.

Forma produsita de la societate Revell GmbH & Co. KG. Toate utilizările sau duplicările frauduloase fără aprobarea noastră sunt strict interzise. Modelado y en propiedad de Revell GmbH & Co. KG. Imitaciones ilícitas serán perseguidas por la ley. Forma prodotta dalla Revell GmbH & Co. KG. e di proprietà della stessa impresa, la quale procederà legalmente contro ogni imitazione abusiva. Malli on Revell GmbH & Co. KG. valmistama ja omaisuutta. Laittamassa kopiointiin tullaan puuttamaan oikeudellisiin toimin. Formen er produceret og er i ejendoms af Revell GmbH & Co. KG. Efterligning uden tilladelse vil bli genstand for retslig forfølgning. Produkcija i pravo vlasništvo firmi Revell GmbH & Co. KG. Neovlašćena podražavanja jest zabronjena pod odgovornosti našeg odjeljenja. Model, Revell GmbH & Co. KG. firmasının mülkiyeti altında imal edilmiştir. Kanuna aykırı taklitler mahkumata takip edilecektir. A forma izdelana je i lastništvo pripada Revell GmbH & Co. KG. A poplnevske odrazitve so hramosilnijsko prenasledjene. Modeli, Revell GmbH & Co. KG. firmasının mülkiyeti altında imal edilmiştir. Kanuna aykırı taklitler mahkumata takip edilecektir. A forma izdelana je i lastništvo pripada Revell GmbH & Co. KG. A poplnevske odrazitve so hramosilnijsko prenasledjene.

Model manufactured by and property of Revell GmbH & Co. KG. Illegal imitations are subject to prosecution.

Forma verswaardigd door en eigendom van Revell GmbH & Co. KG. Overrechtelijke nabootelingen worden gerechtelijk vervolgd. Forma produsida e de proprietate de Revell GmbH & Co. KG. Copii nro autorizate sunt procesate juridicament ca determinat na lei. Modelen öbervakad av och öllbar Revell GmbH & Co. KG. All kopiering beivras enligt lagen om upphövrätt. Formen er fremstillet af Revell GmbH & Co. KG. Imitationer uden tilladelse vil blive genstand for retslig forfølgning. Modeli, Revell GmbH & Co. KG. firmasının mülkiyeti altında imal edilmiştir. Kanuna aykırı taklitler mahkumata takip edilecektir. A forma izdelana je i lastništvo pripada Revell GmbH & Co. KG. A poplnevske odrazitve so hramosilnijsko prenasledjene.







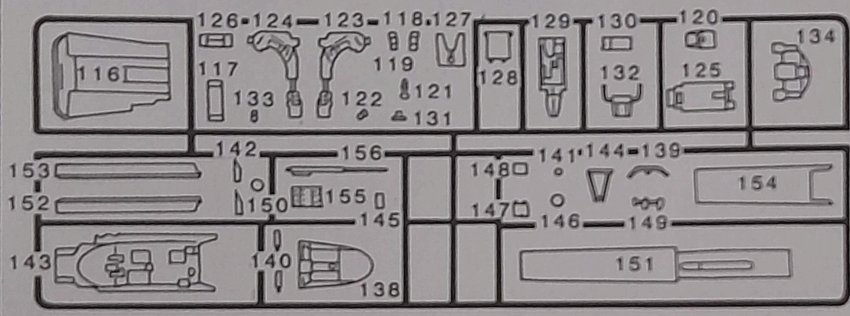
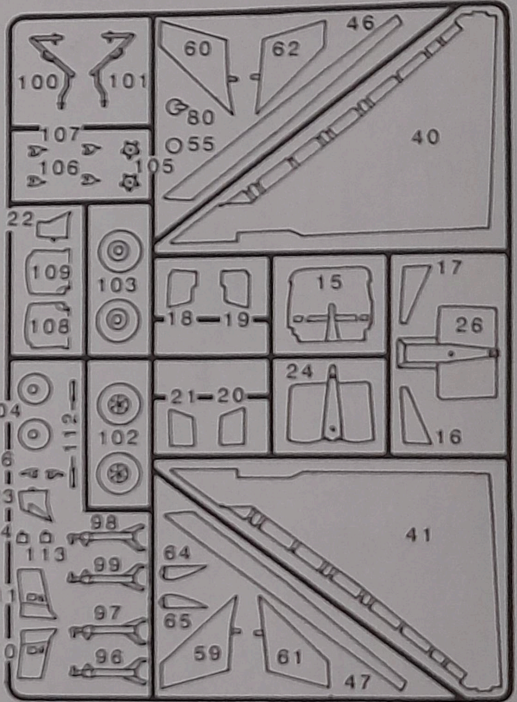
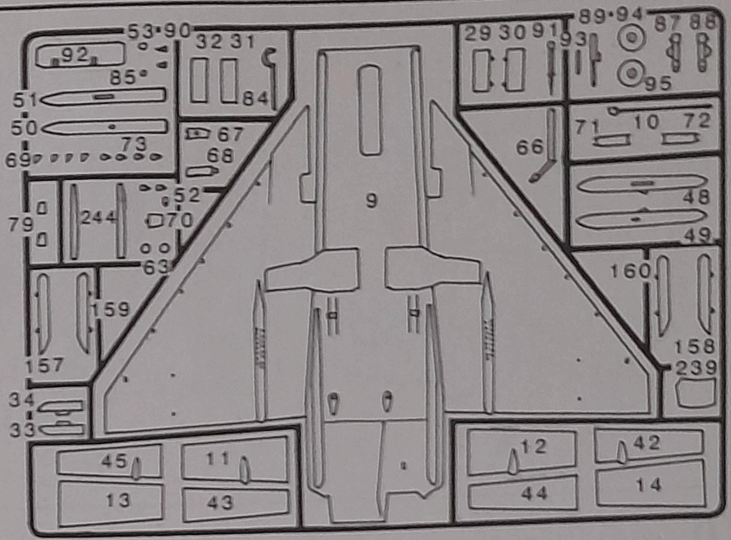
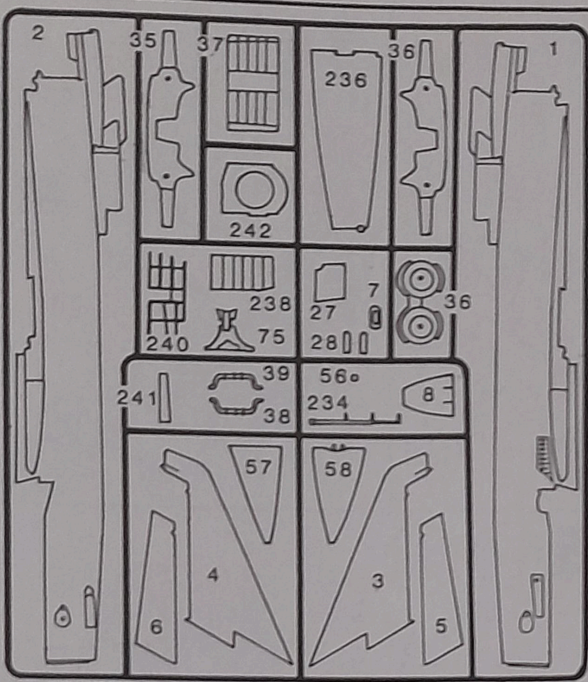

2X

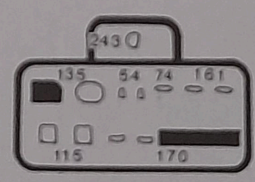
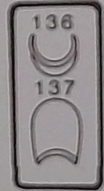
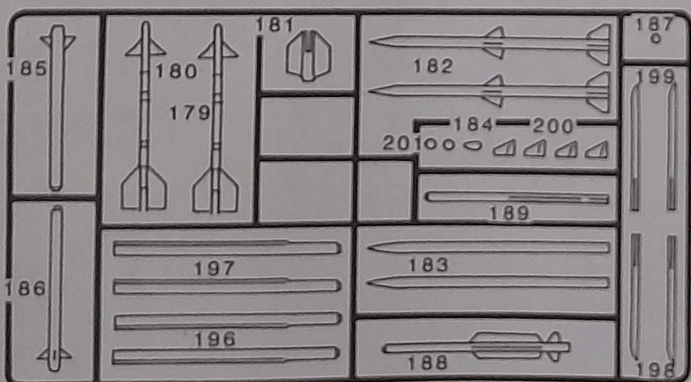

2X

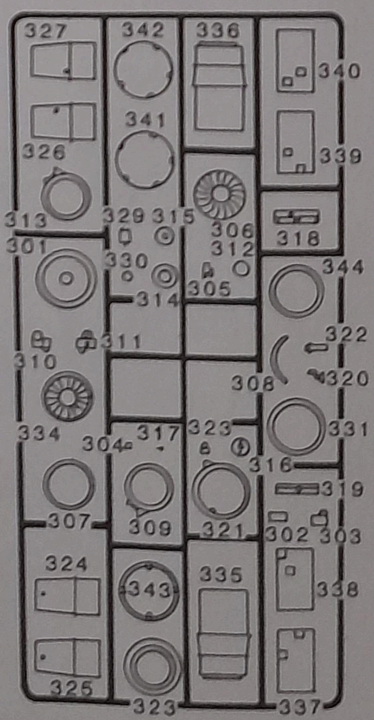
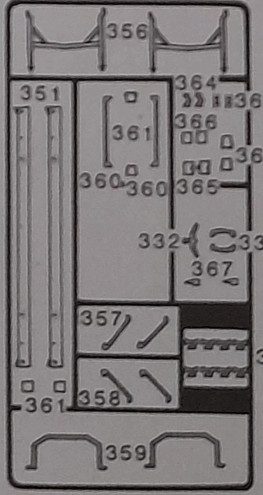
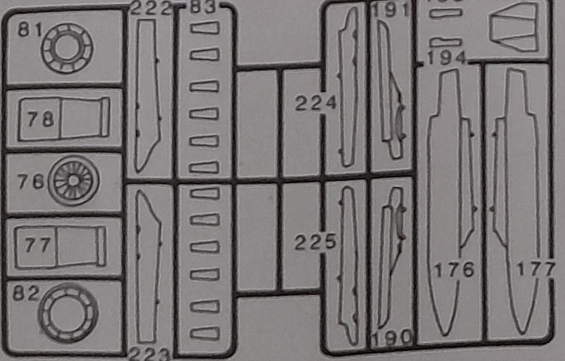

1

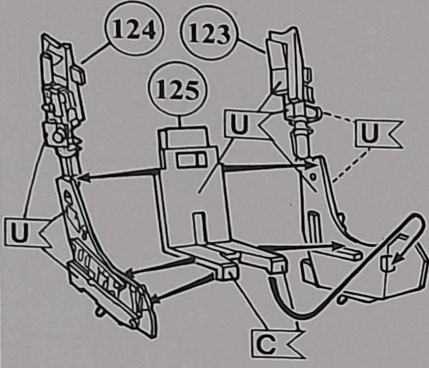

2

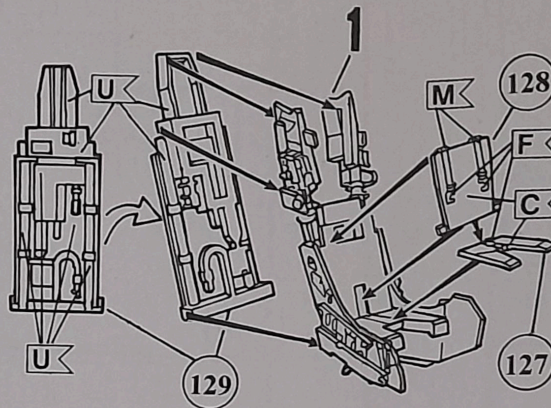

3

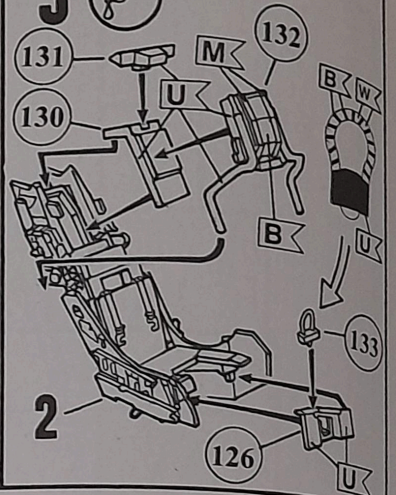

4

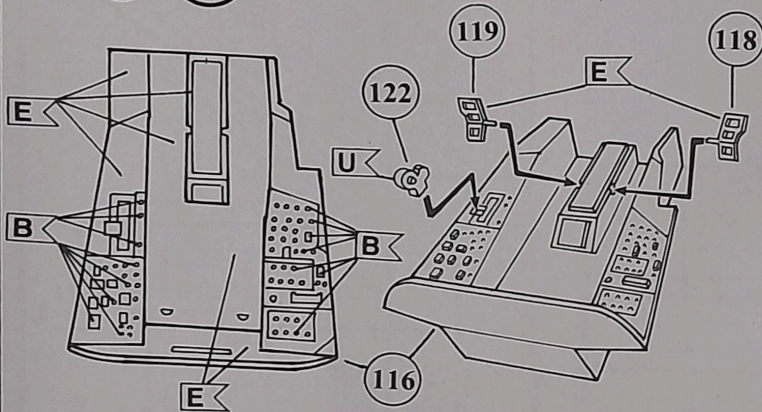

5

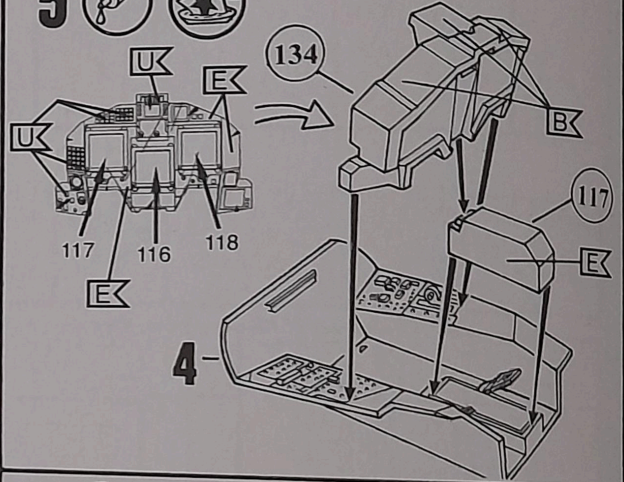

6

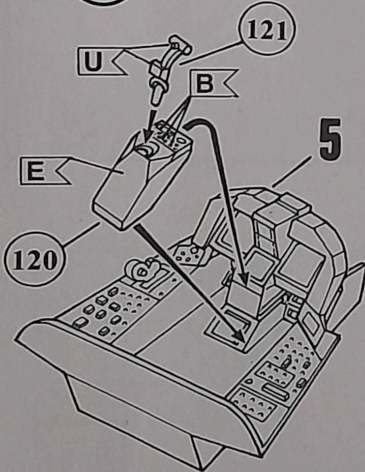

7

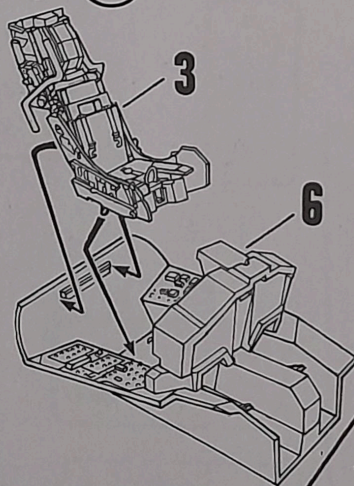

8

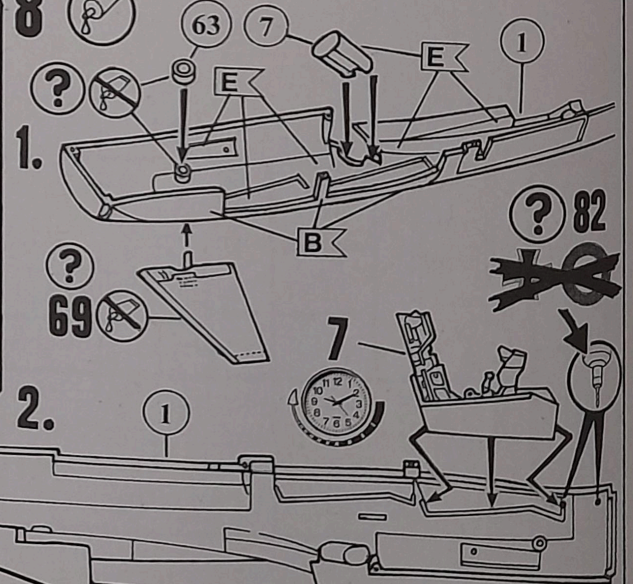

9

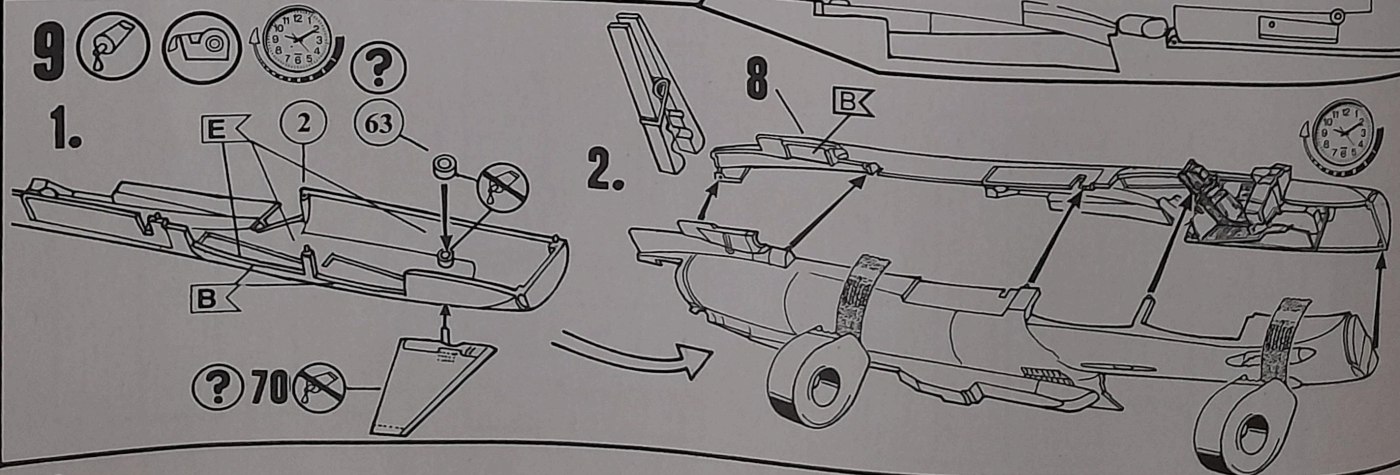

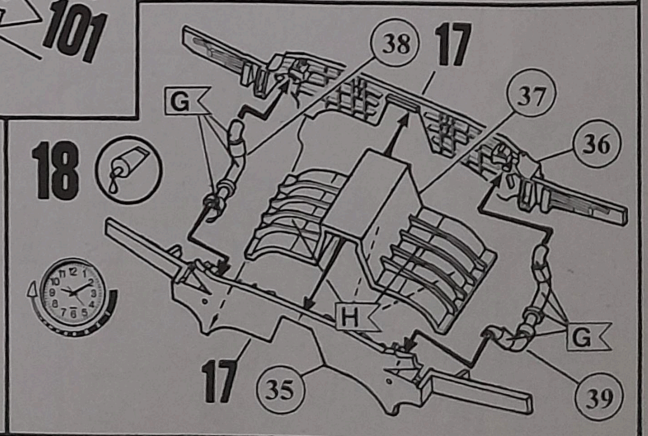
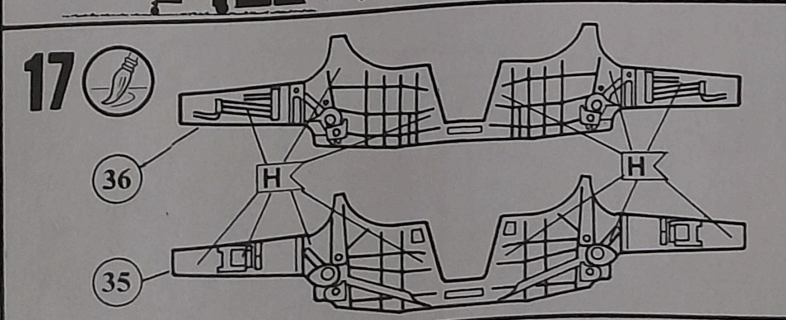
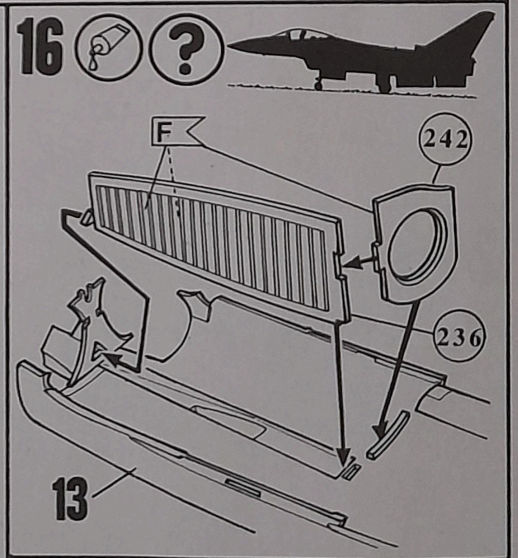
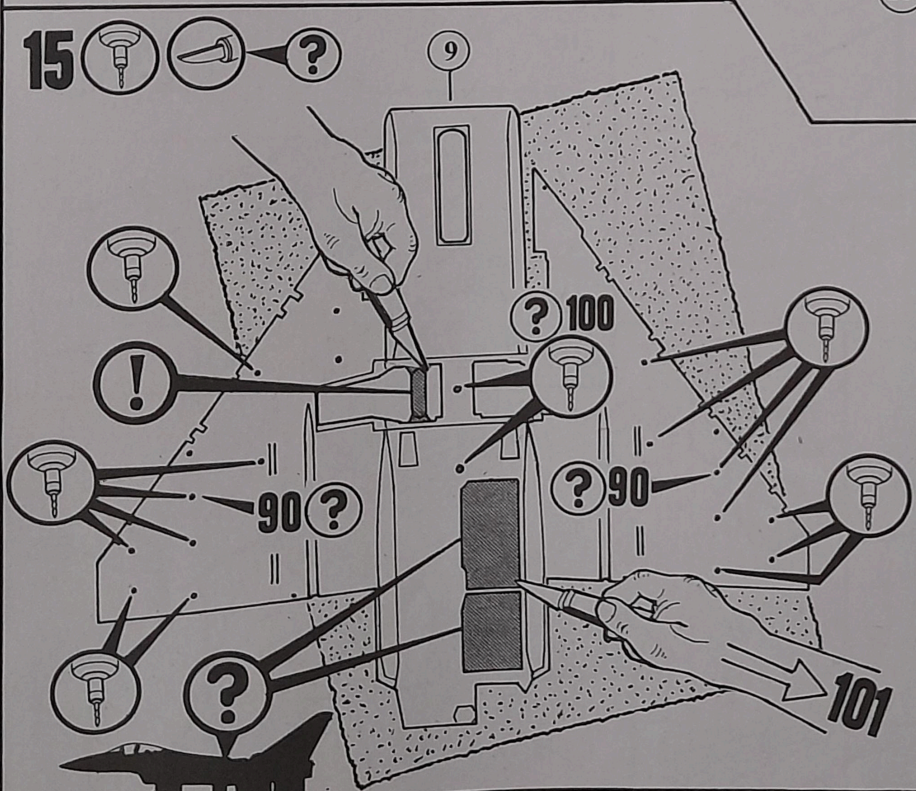
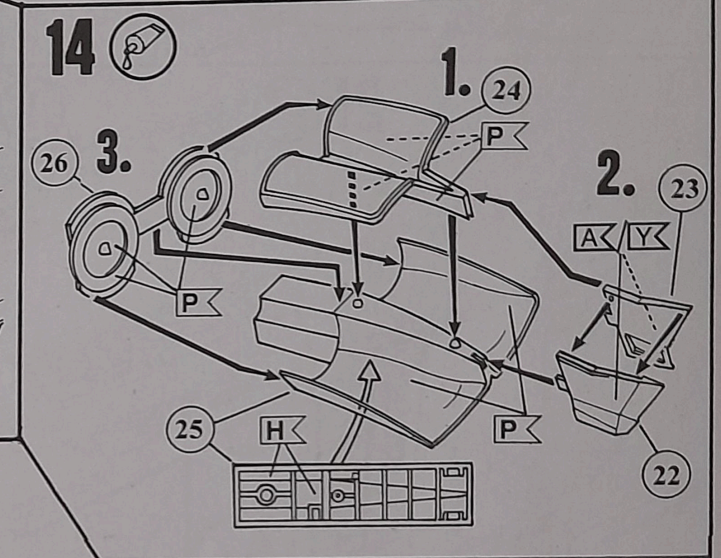
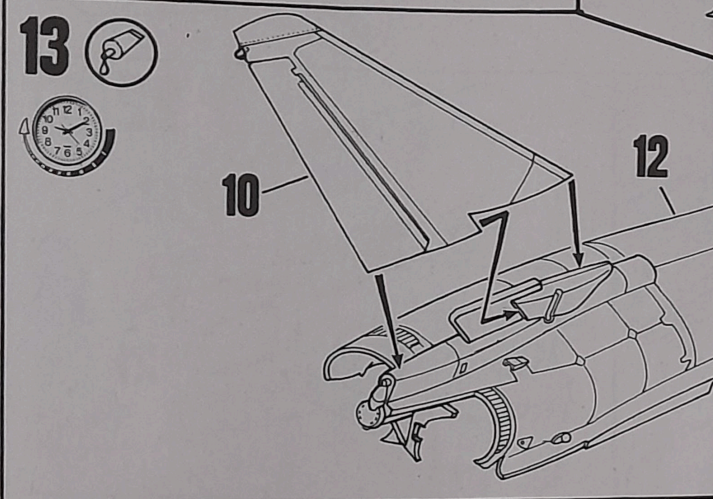
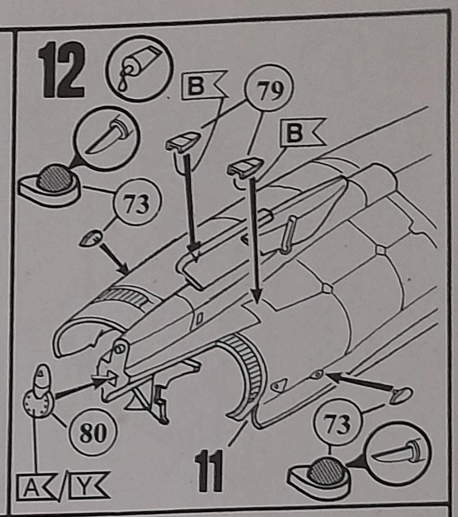
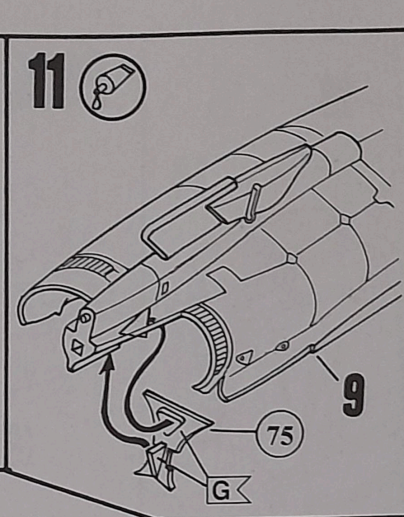
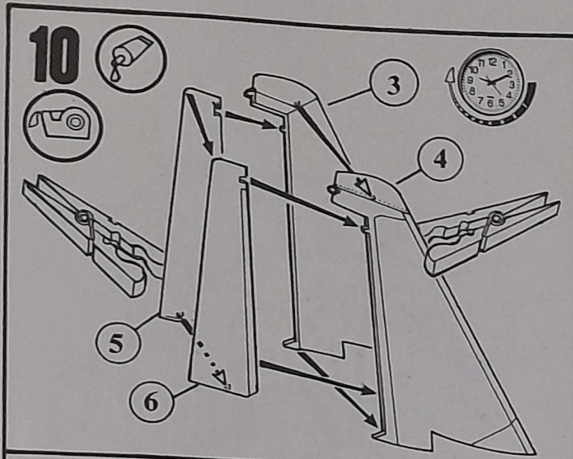

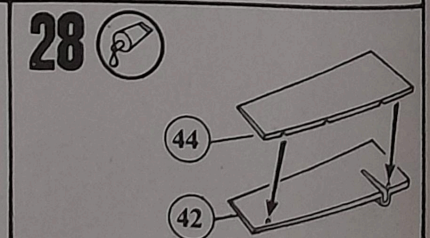
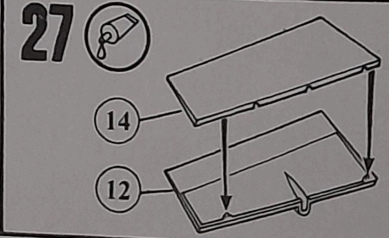
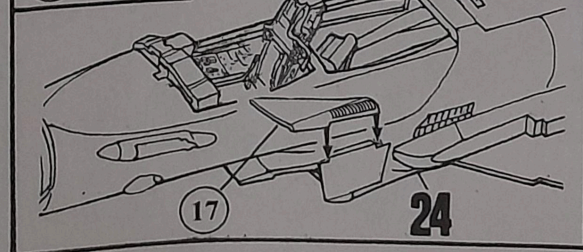
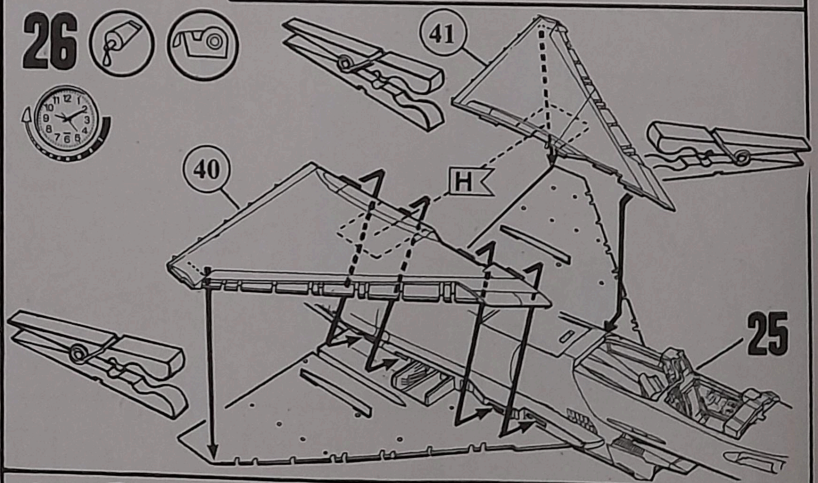
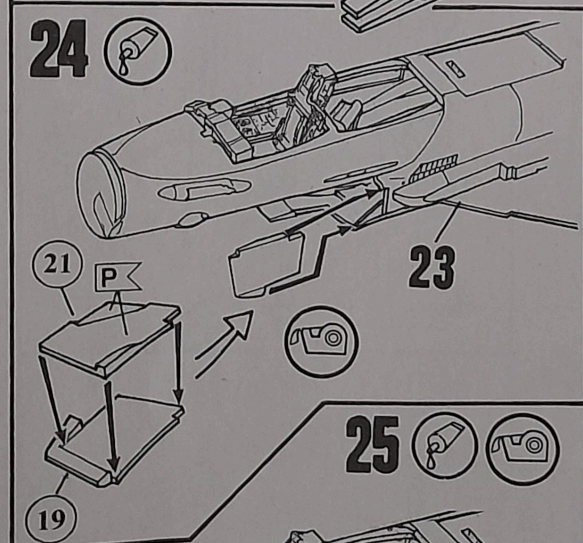
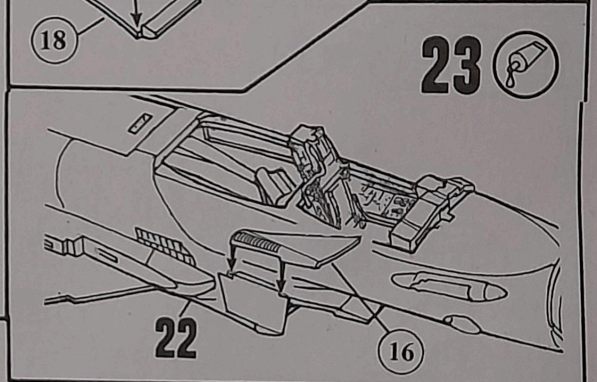
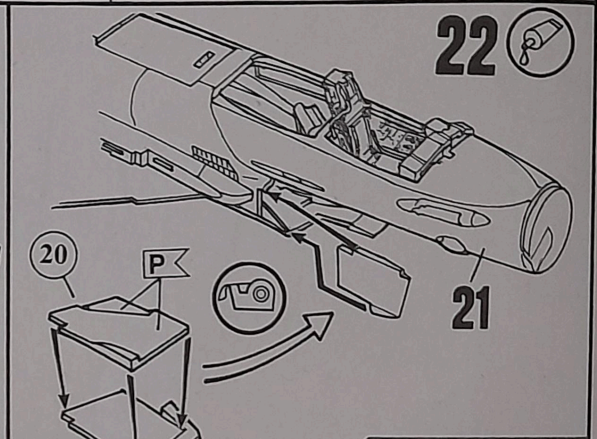
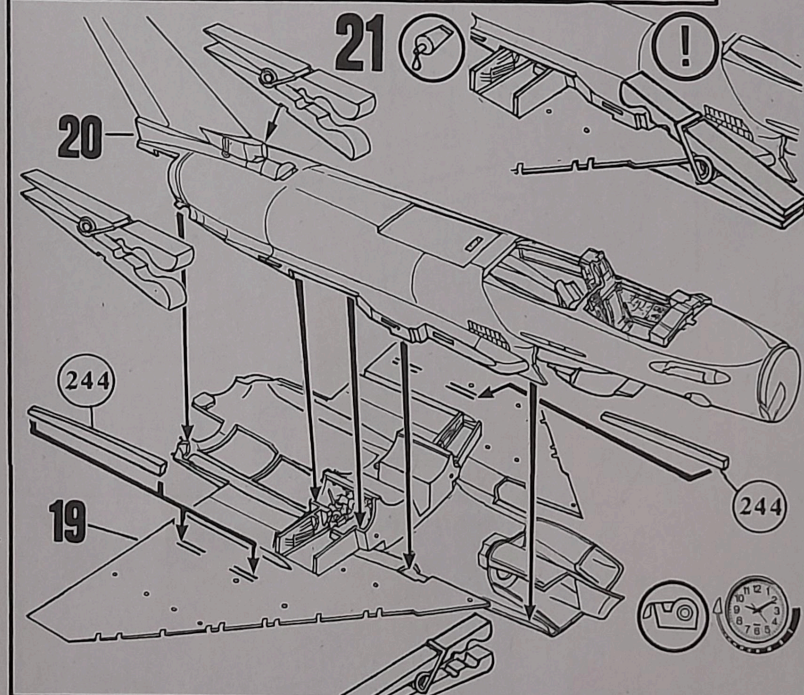
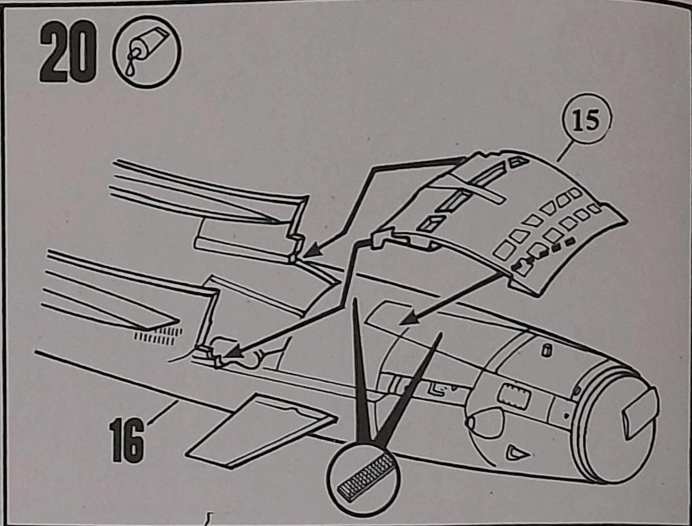
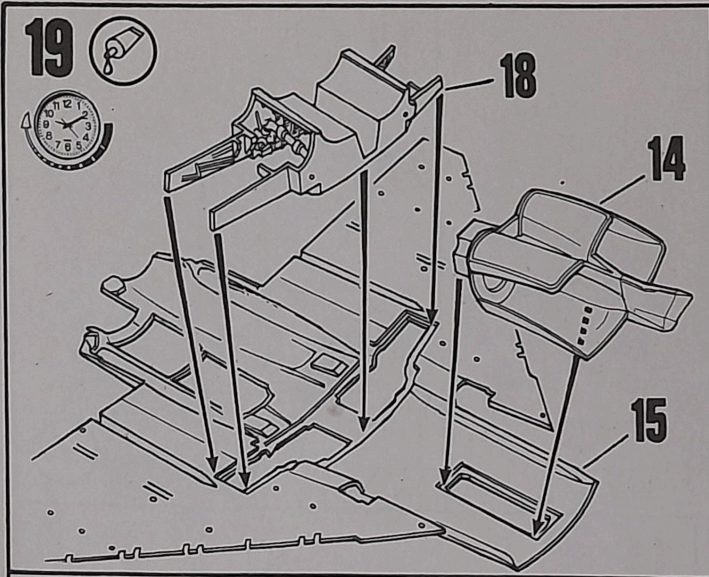



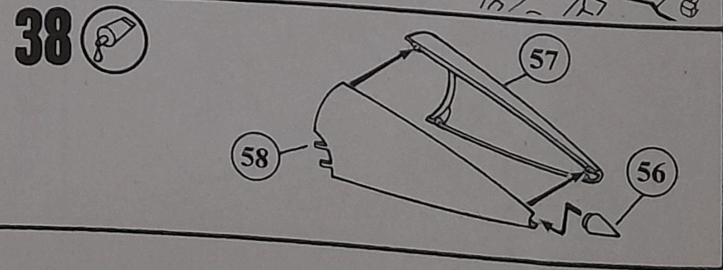
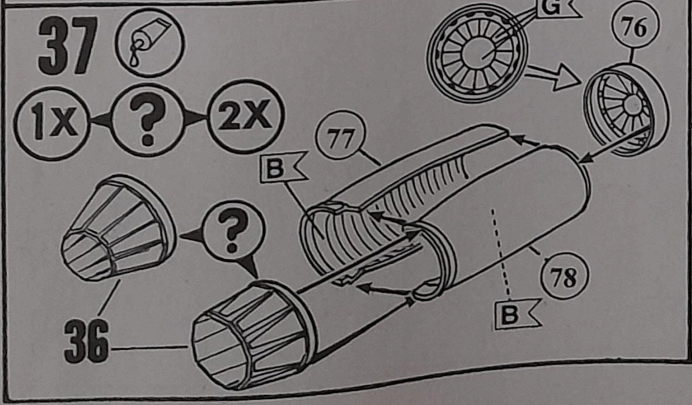
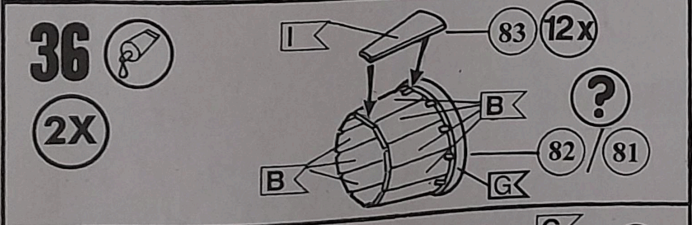
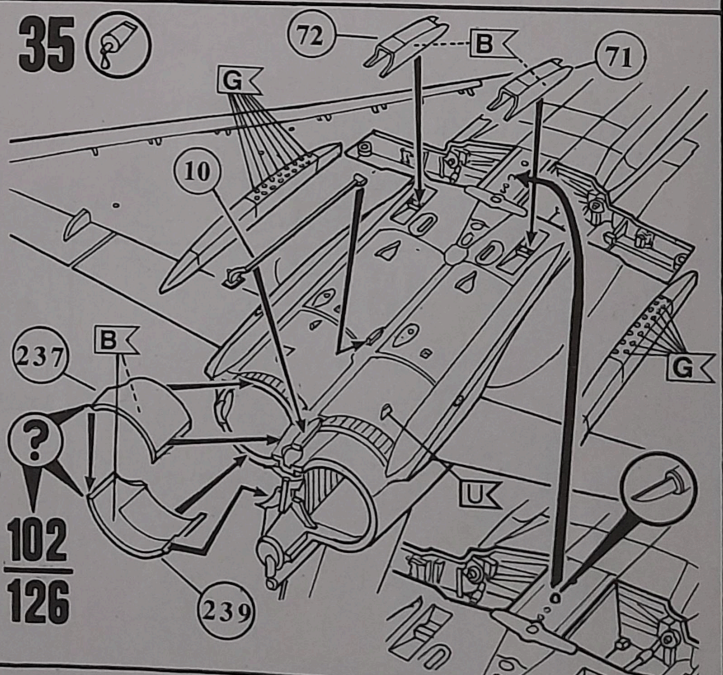
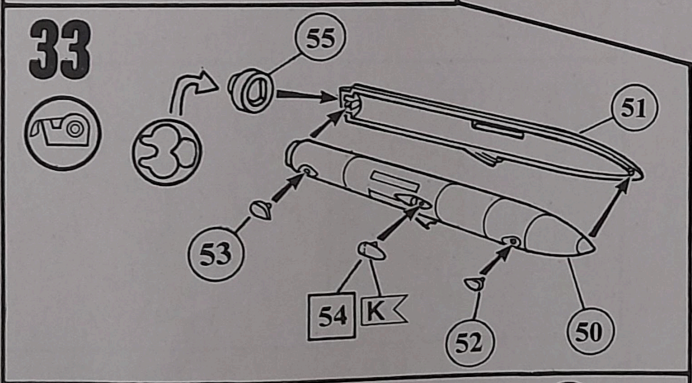
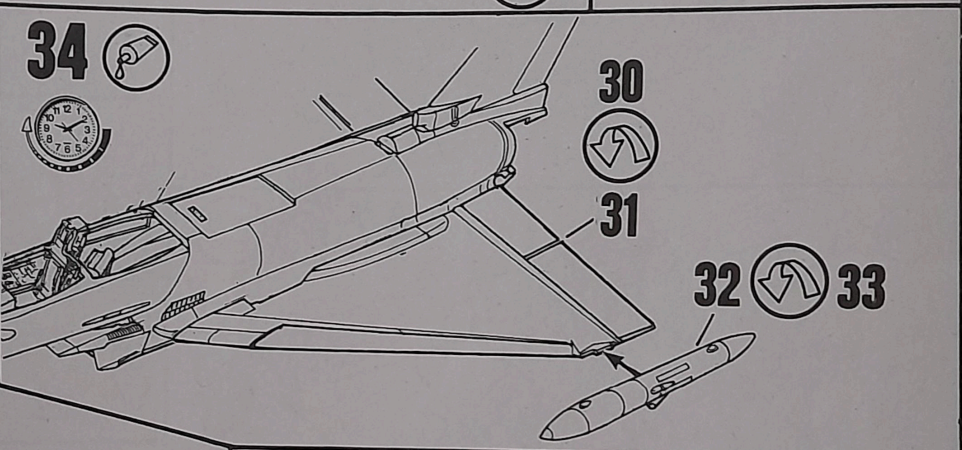
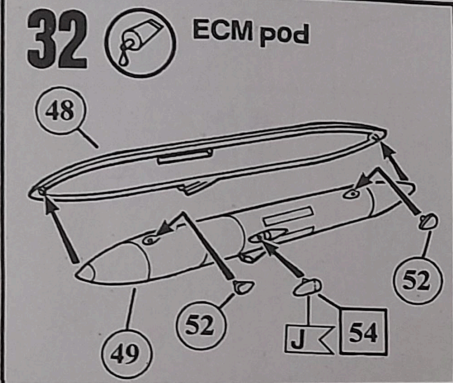
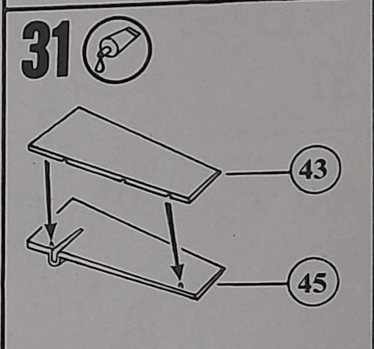
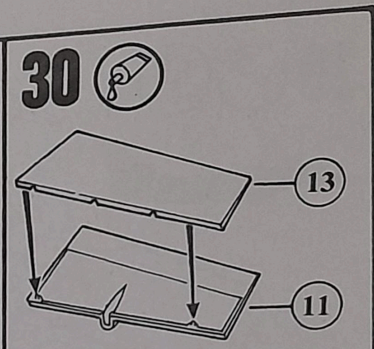
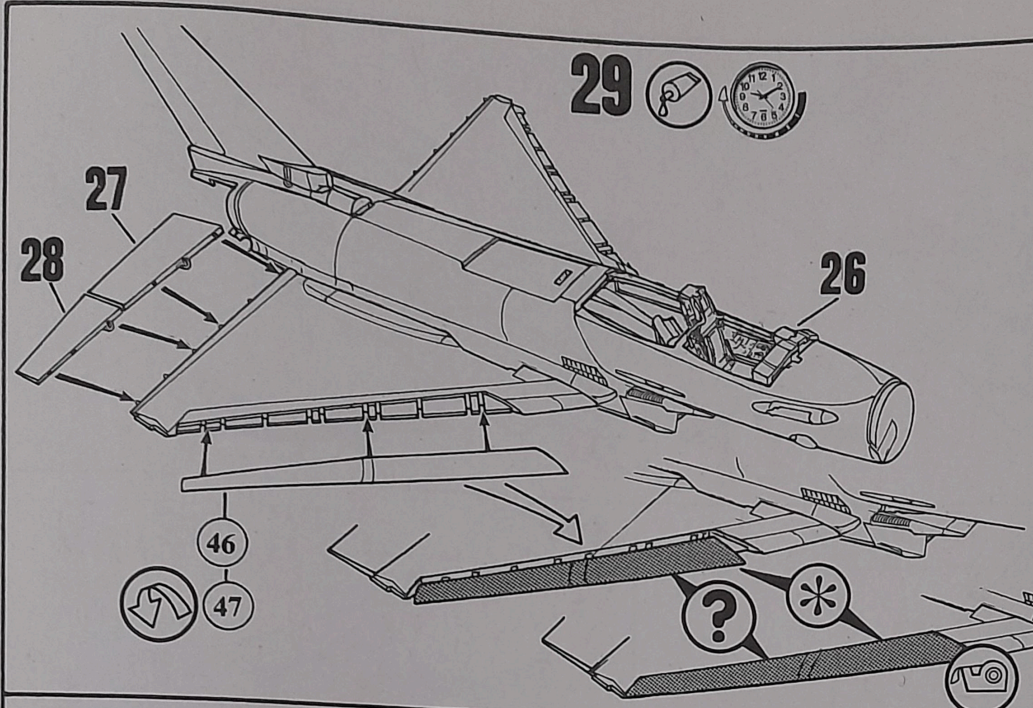



39  

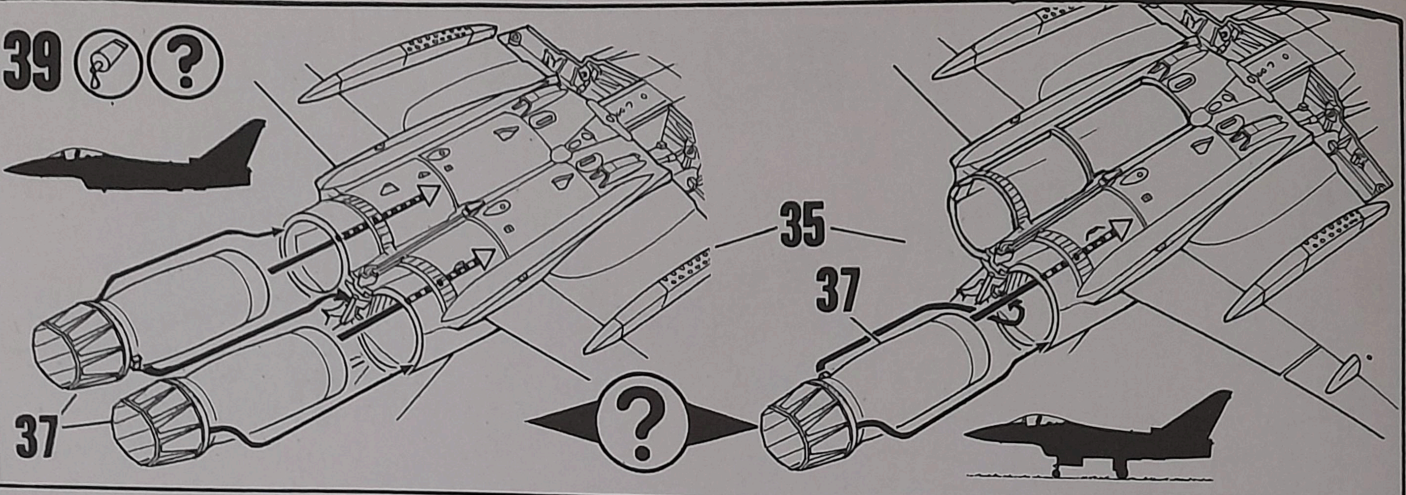

40 

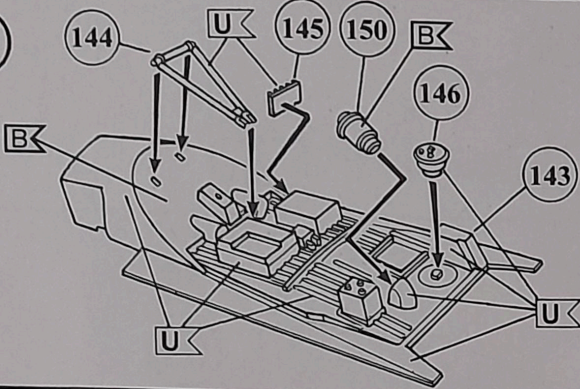

41 

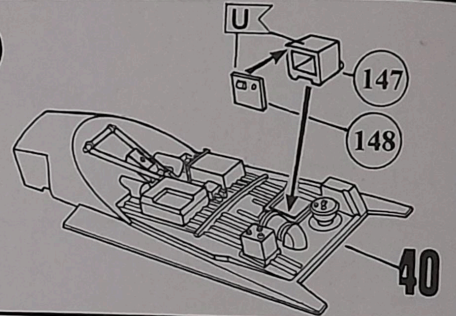

42  

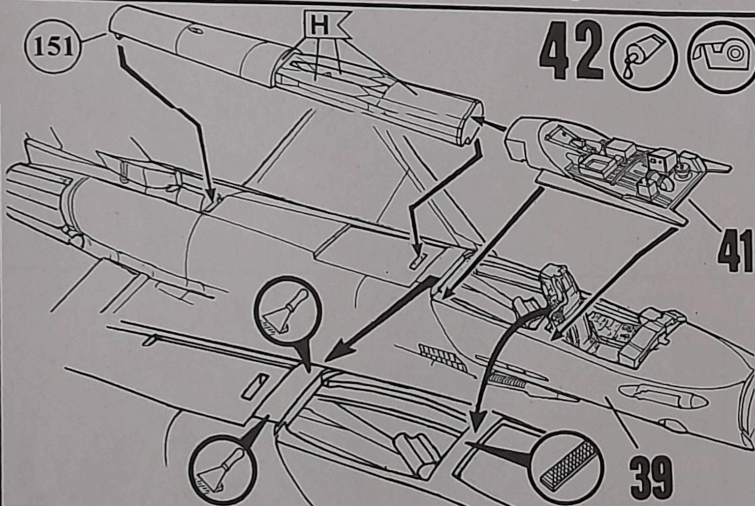

43 

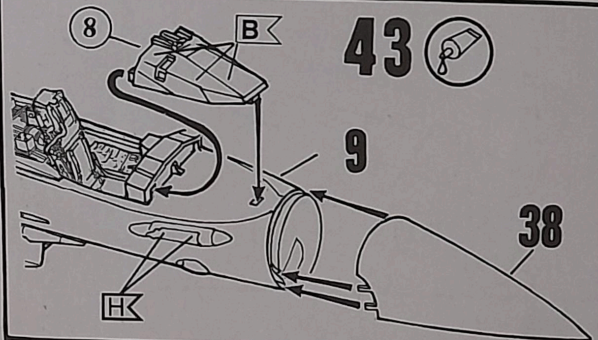

44 

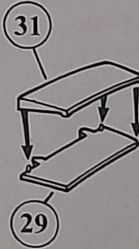

45 

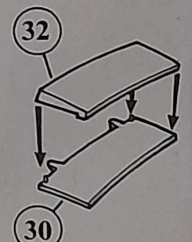

46 

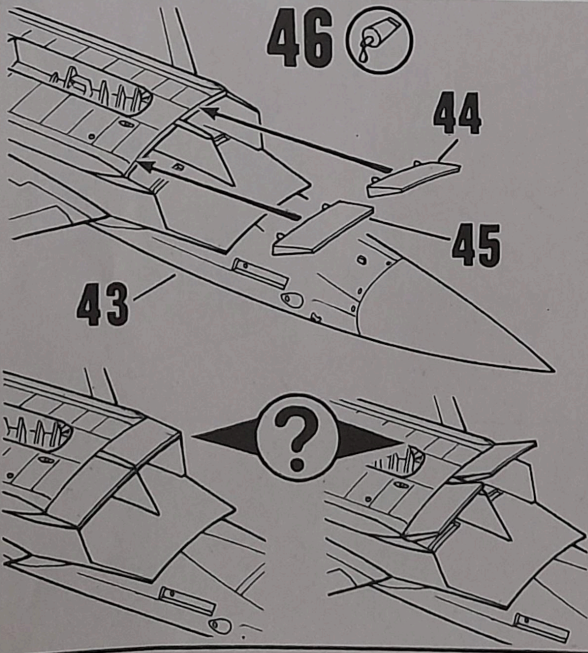

47  

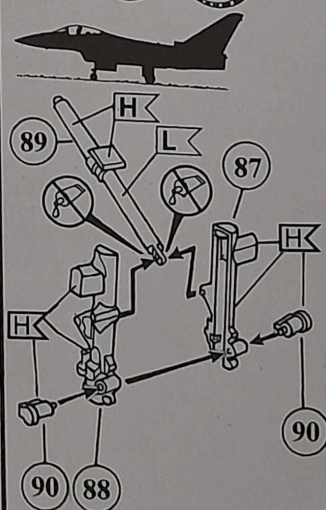

48 

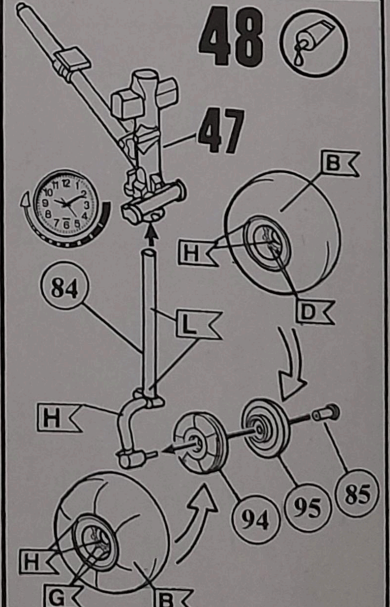

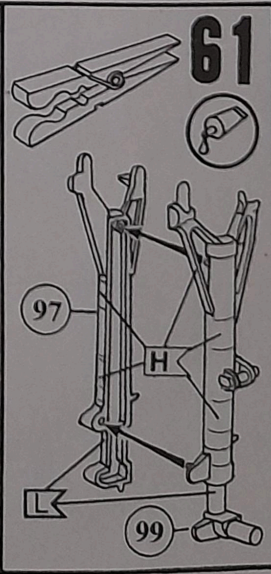
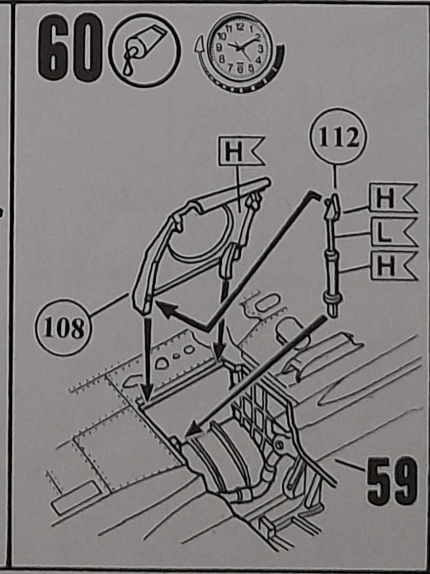
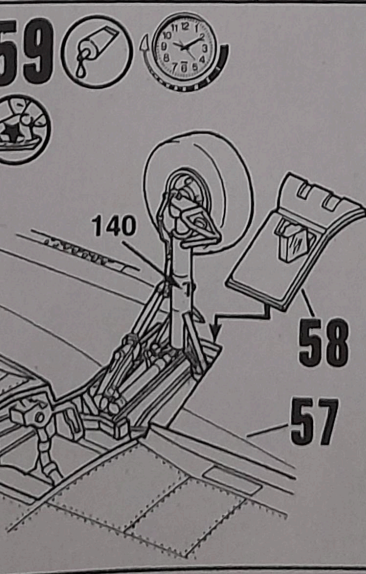
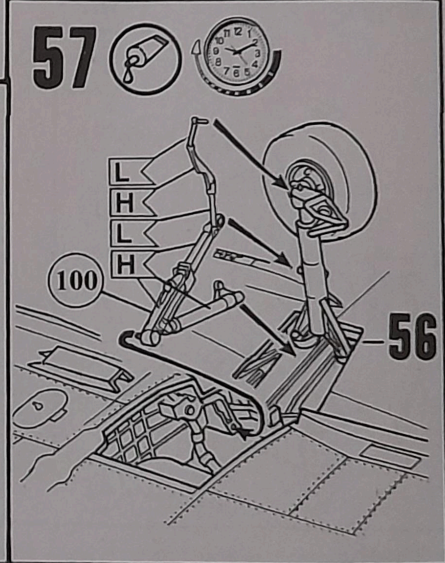
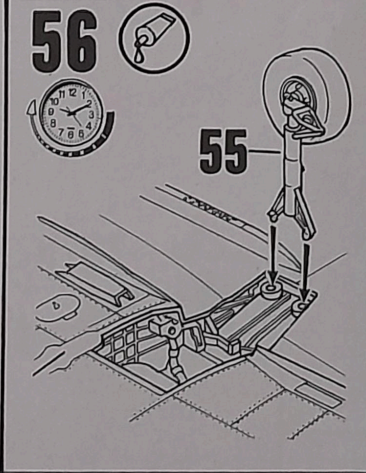
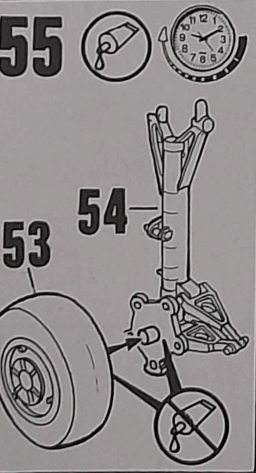
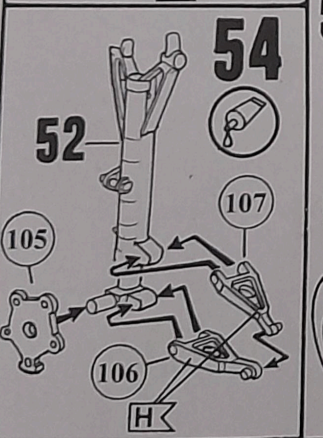
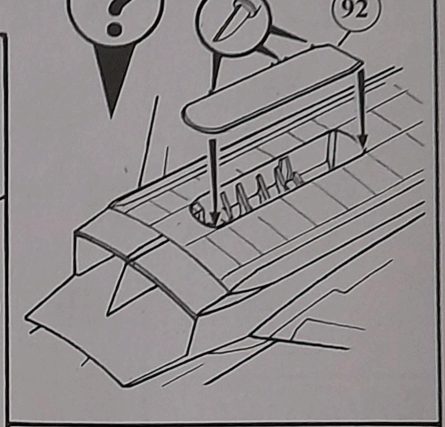
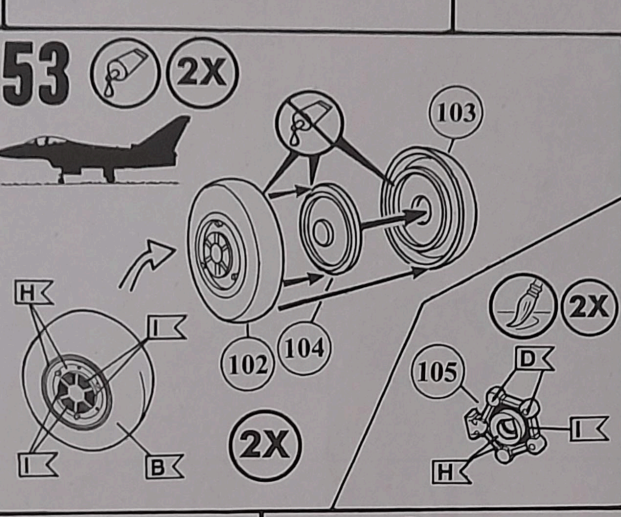
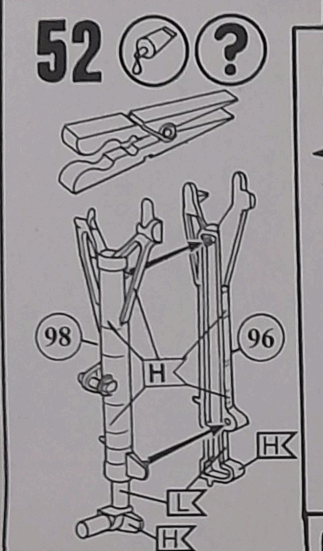
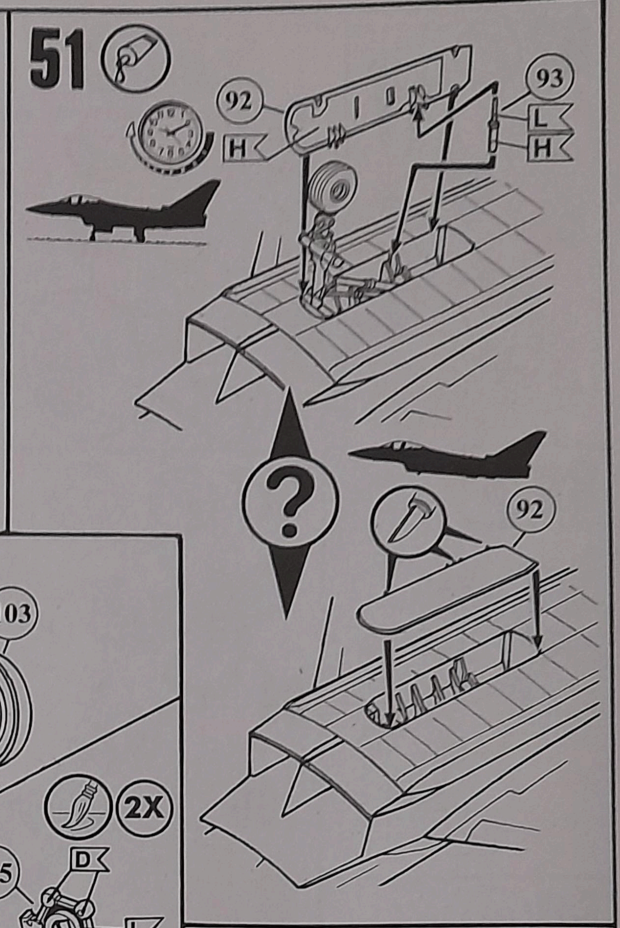
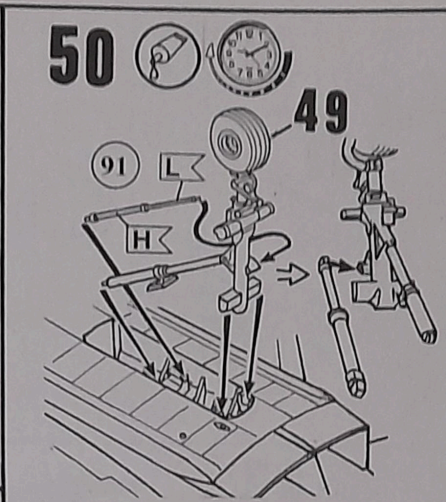
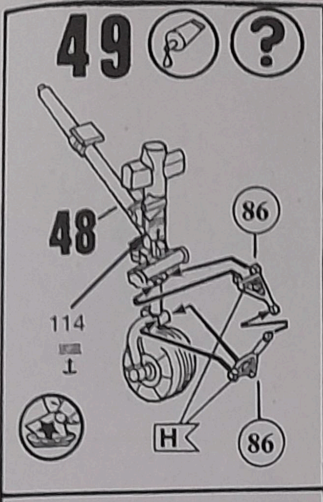

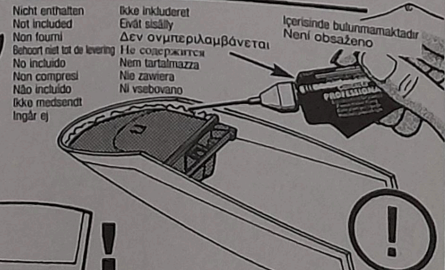
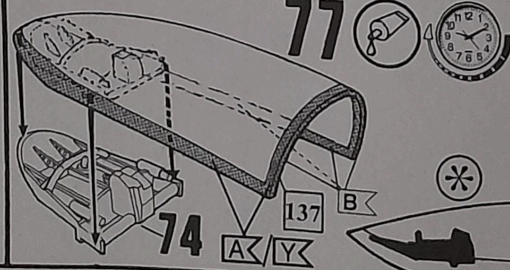
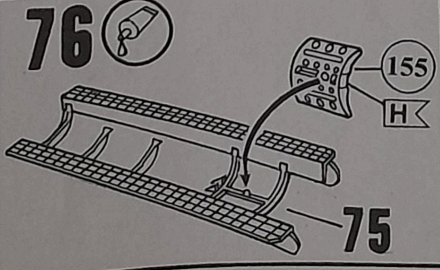
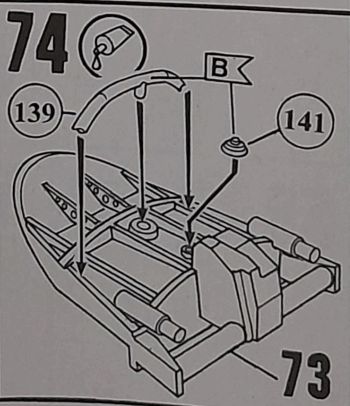
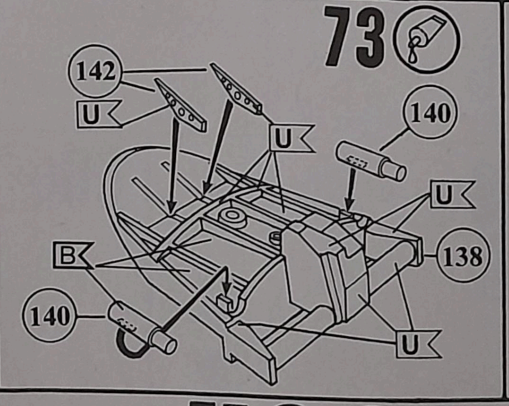
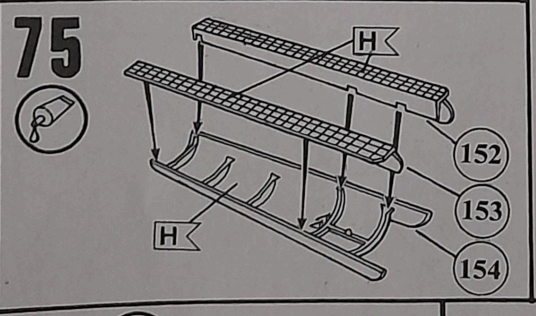
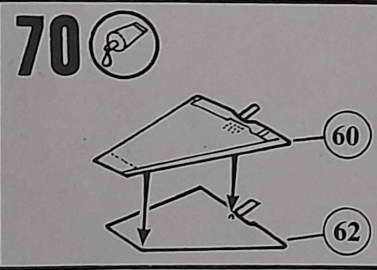
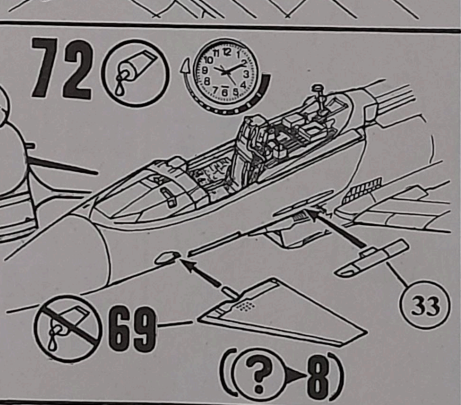
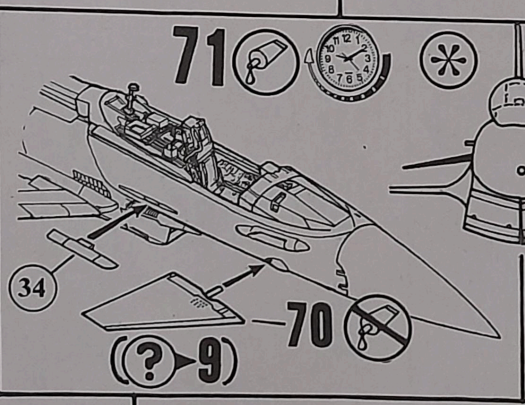
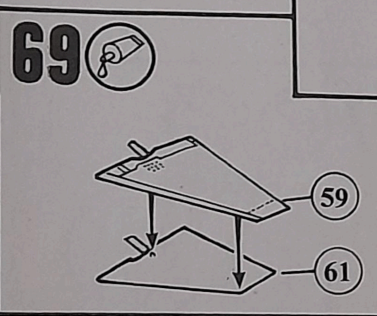
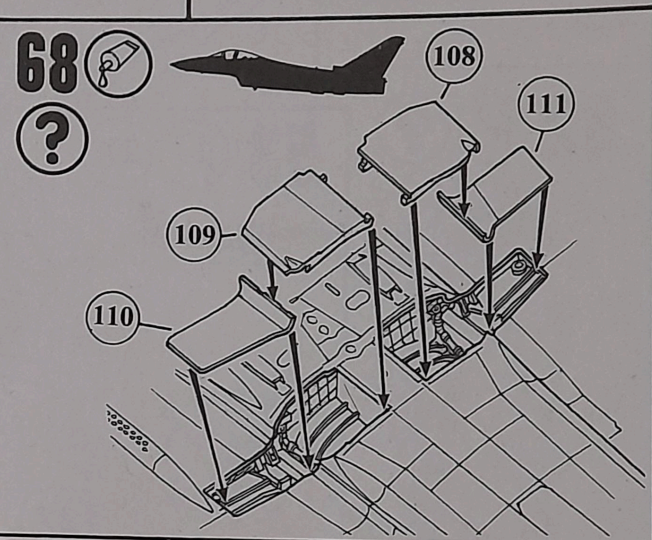
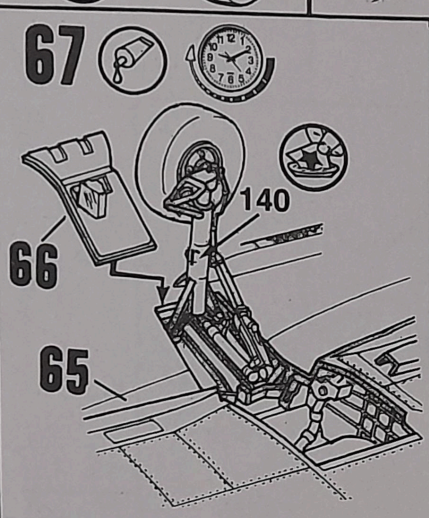
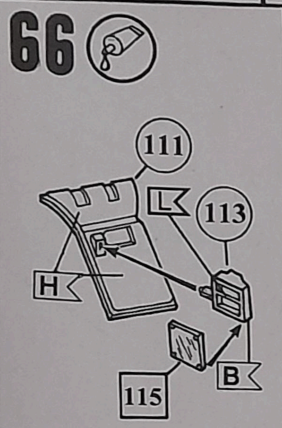
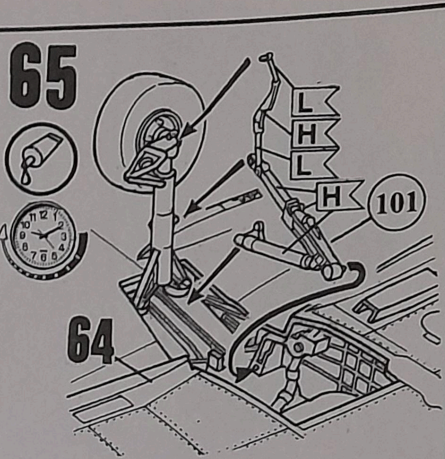
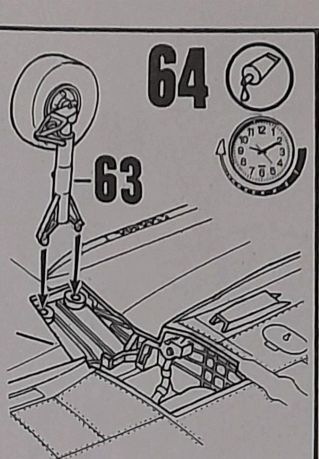
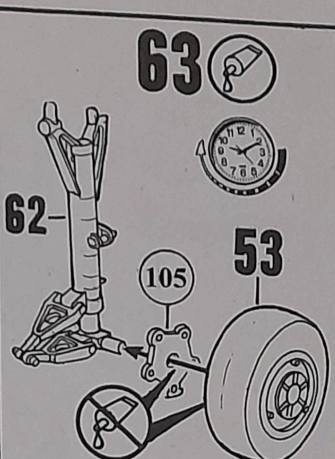
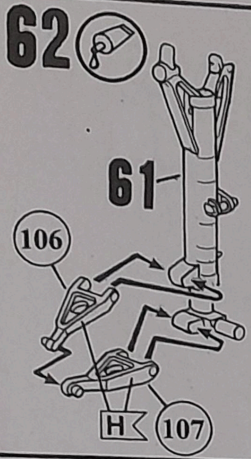

Nicht enthalten  
Not included  
Non forniti  
Belmont niet tot de levering  
No include  
Non compresi  
Não incluido  
Ikke medsendt  
Inglár ej

Ikke inkluderet  
Eivät sisälly  
Δεν συμπεριλαμβάνεται  
Не включается  
Nem tartalmazza  
Nio zawiera  
Ni vsebovano

İçerisinde bulunmamaktadır  
Neni obsazeno

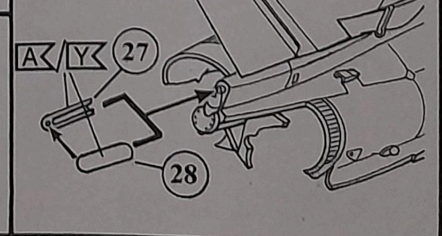
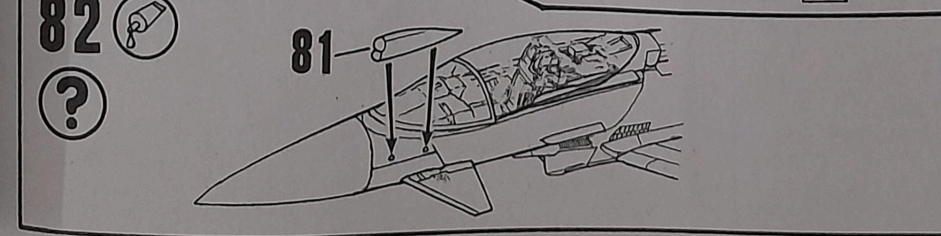
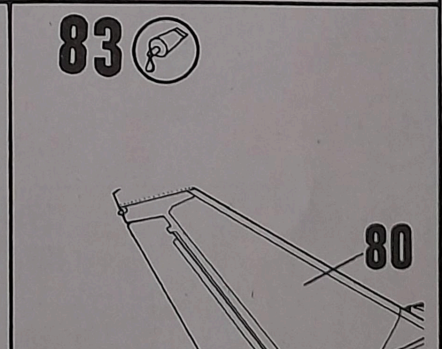
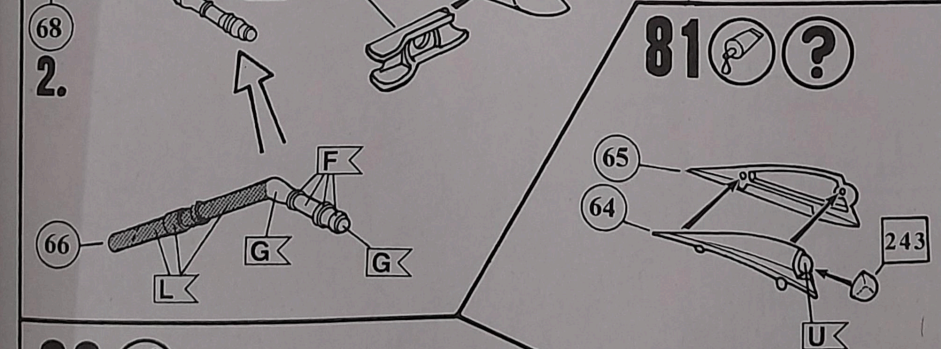
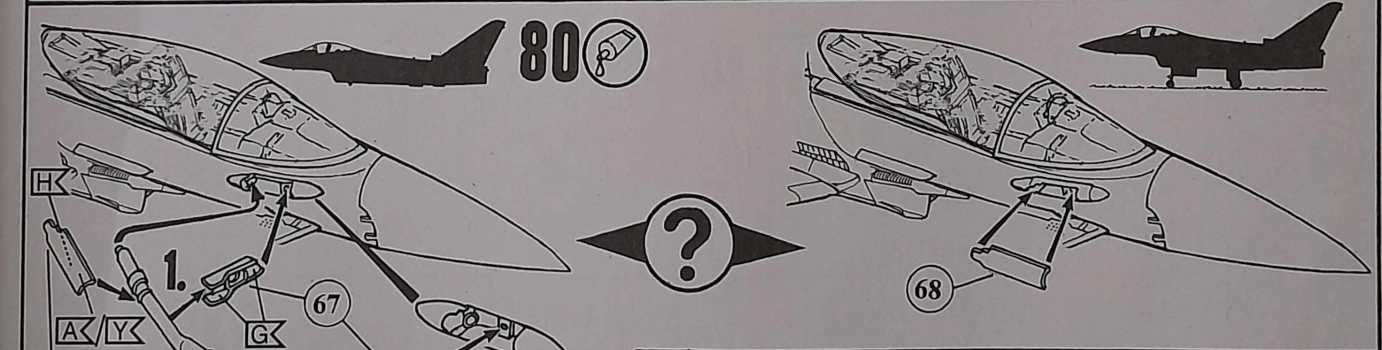
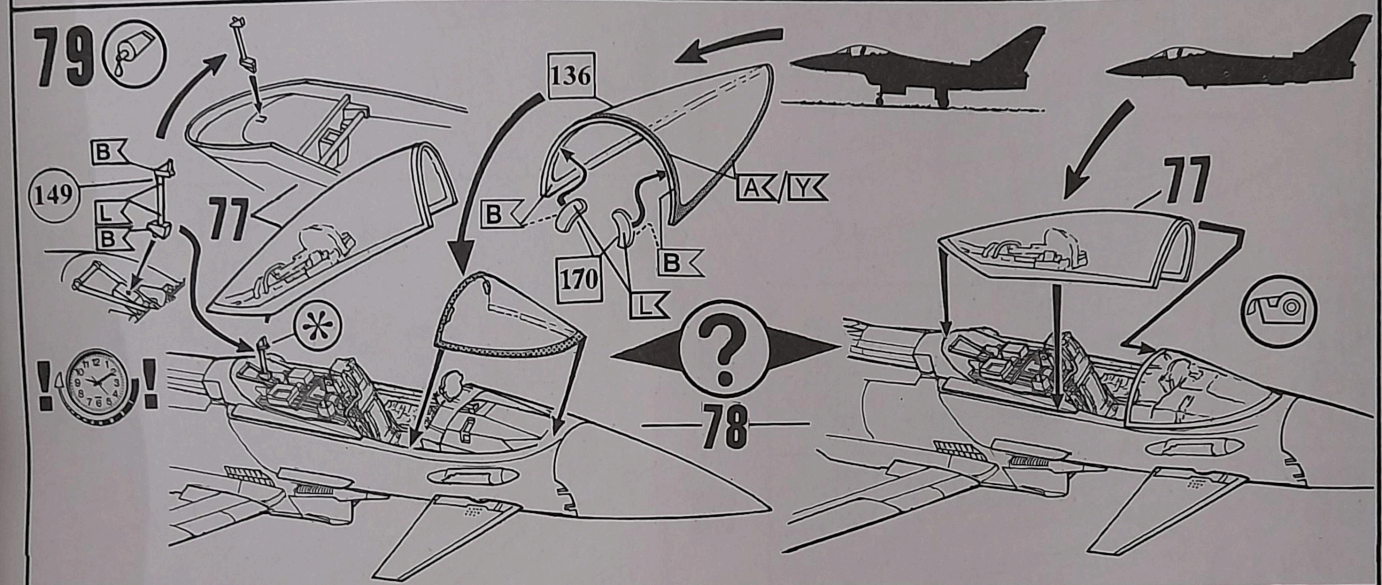
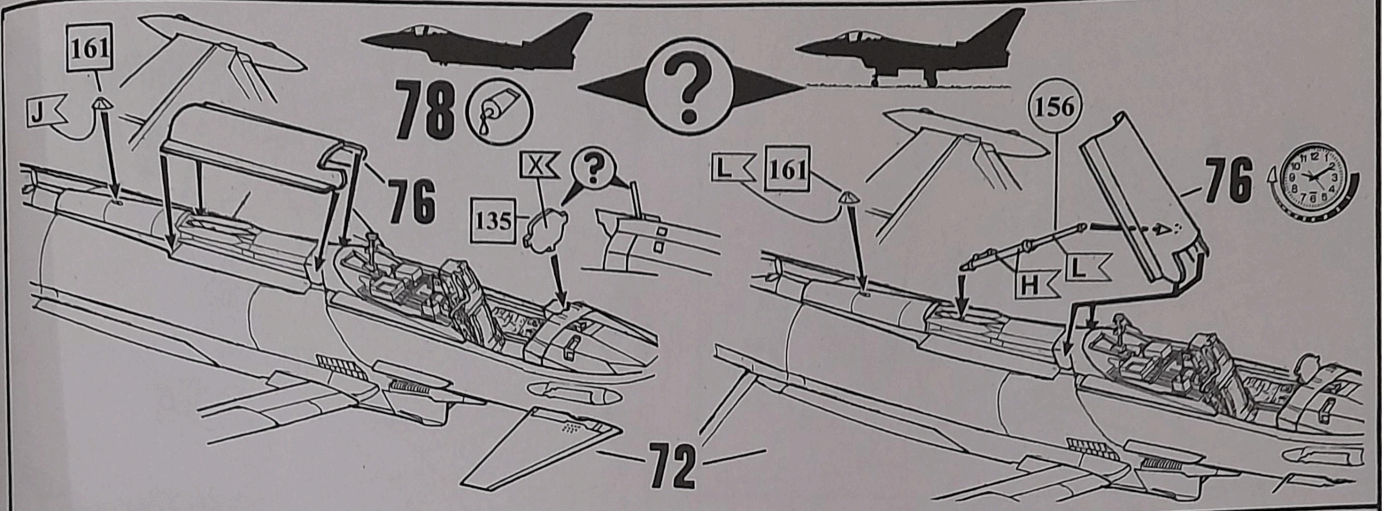

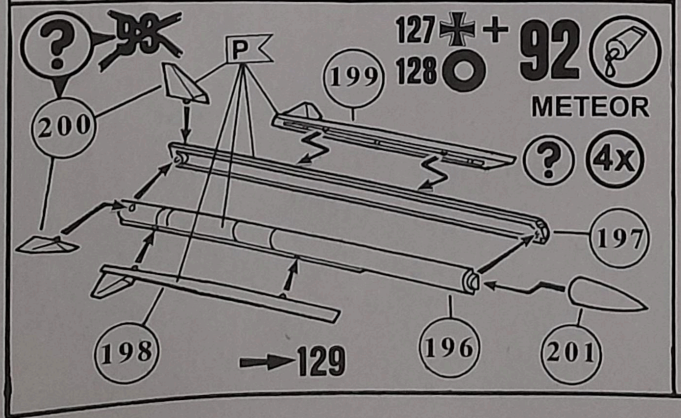
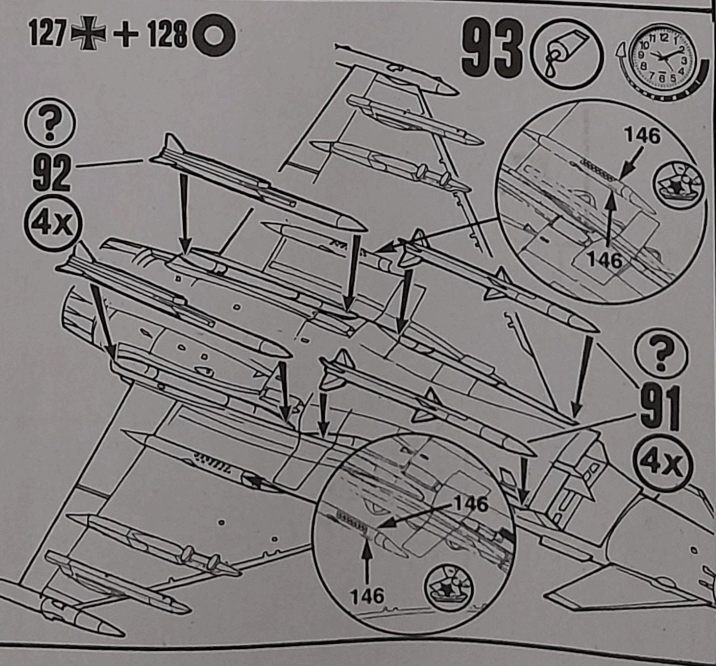
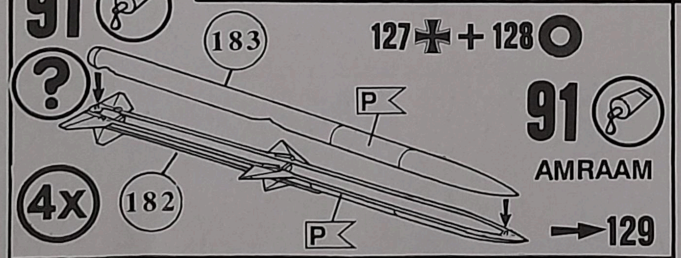
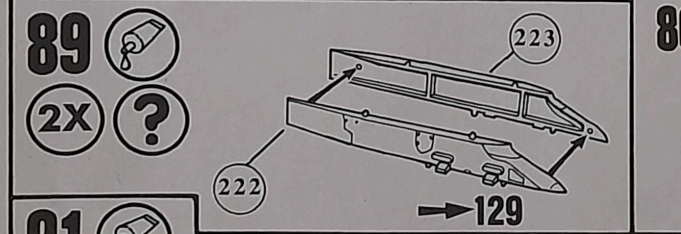
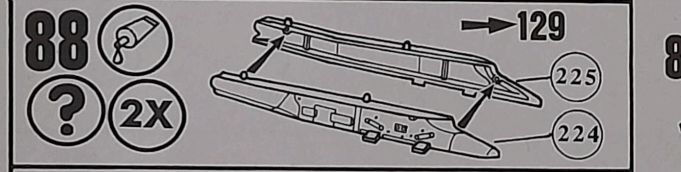
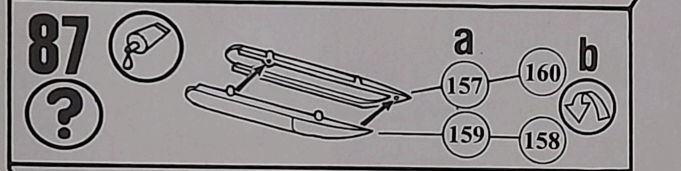
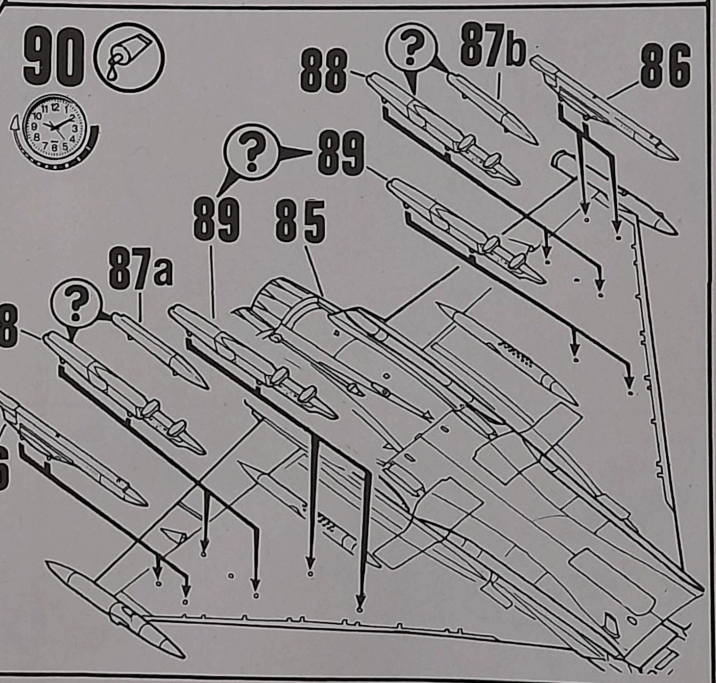
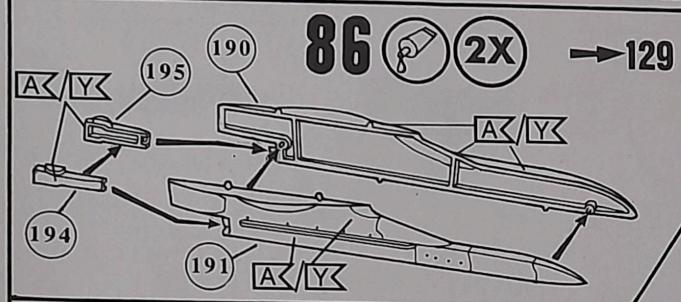
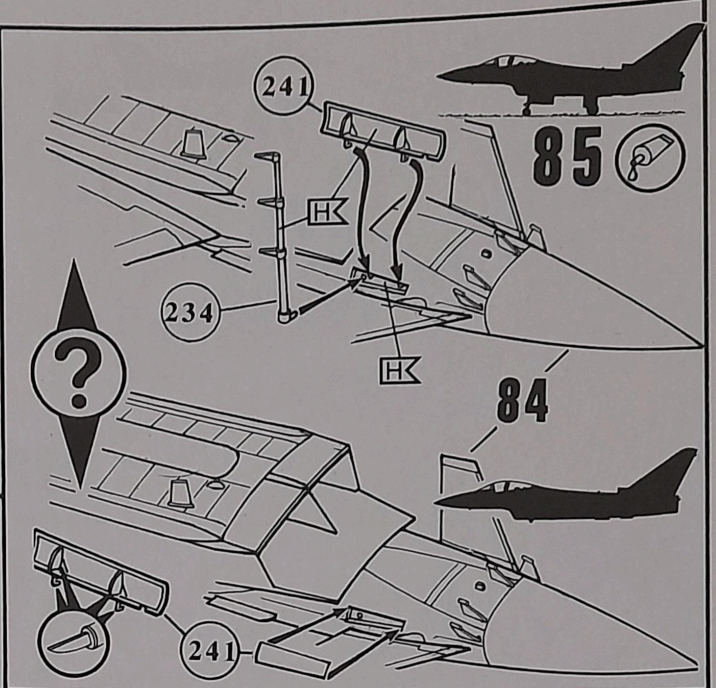
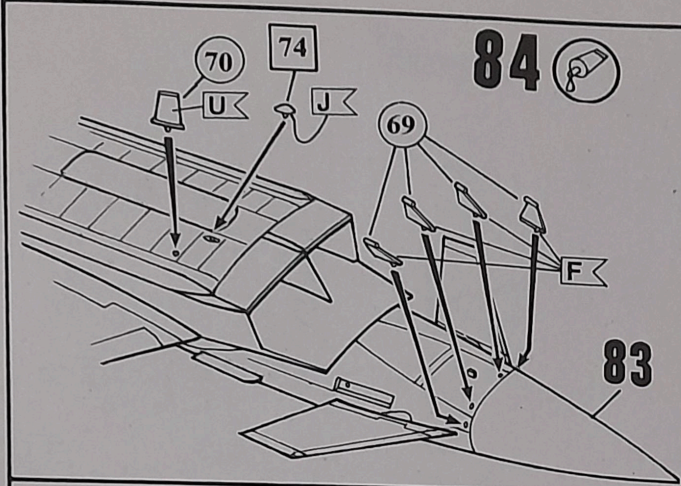

127 ✖ + 128 ○

**94** (Screwdriver icon) (2X) (?) (1X)

1000L TANK

(?)

178

A Y

177

176

→ 129

127 ✖ + 128 ○

**97** (Screwdriver icon)

(Clock icon)

(?)

**94** (?)

**96** (?)

127 ✖

**95** (Screwdriver icon) (2X) (?)

AIM-9L SIDEWINDER

180

OK HK

L

181

179

→ 129

127 ✖

**98** (Screwdriver icon) (?)

(Clock icon)

(?)

**96** (?)

**95** (?)

**99** (Screwdriver icon) (?) (2X)

128 ○

AIM-132 ASRAAM

185

P

186

184

L

→ 129

**96** (Screwdriver icon) (2X) (?) 128 ○

IRIS-T

188

Q

189

187

→ 129

**100** (Screwdriver icon) (?)

(Clock icon)

127 ✖

**94** (?)

128 ○

**99** (?)

**95** (?)

**101** (Screwdriver icon) (?)

(?)

**238**

**240**

**15**

F

F

→ 15

**102** (Screwdriver icon)

(Clock icon)

**101**

# 103 EJ200 engine

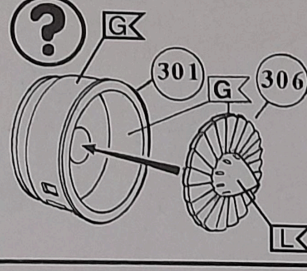

# 104

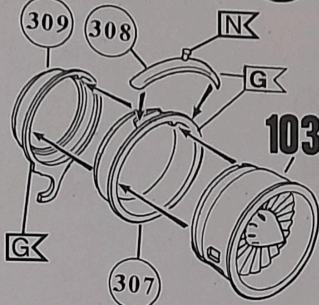

# 105

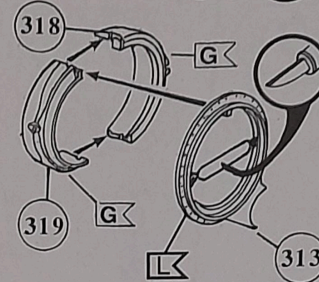

# 106

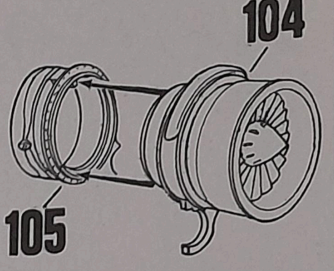

# 107

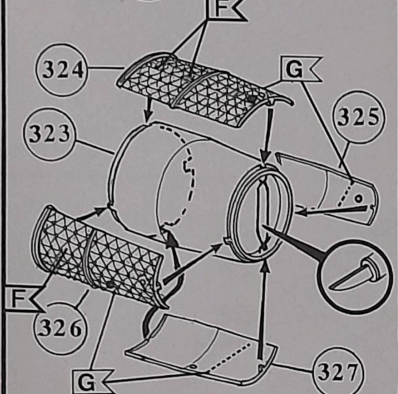

# 108

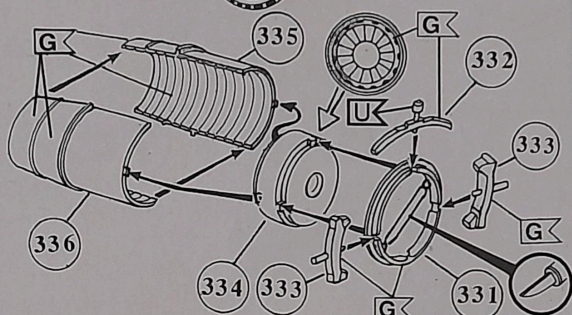

# 109

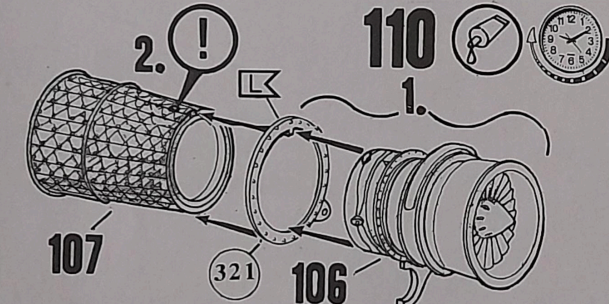
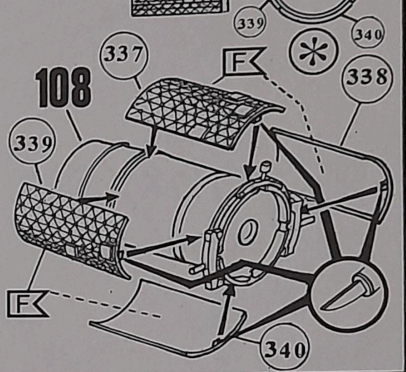

# 111

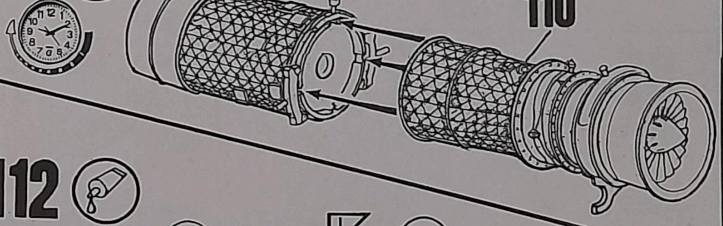

# 112

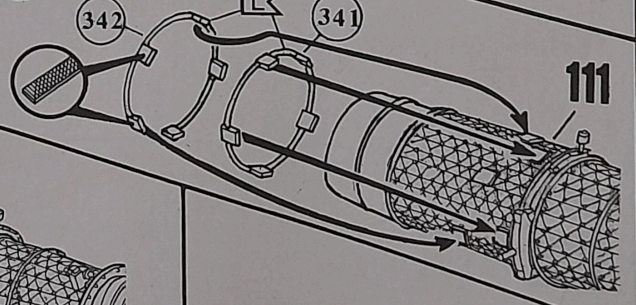

# 113

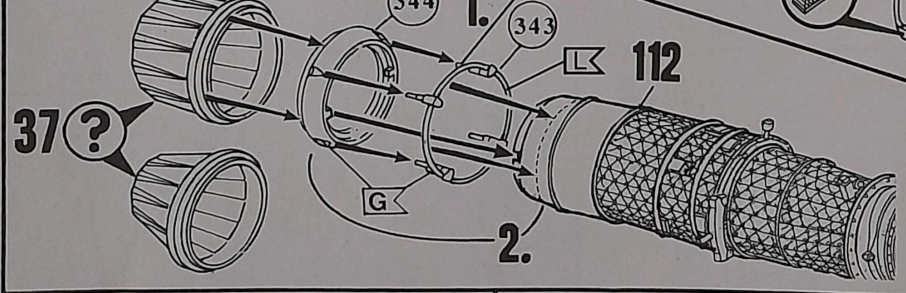

# 114

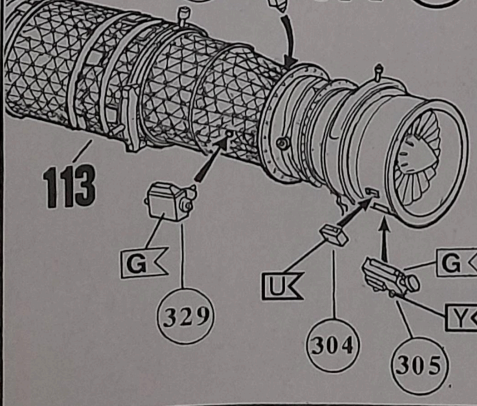

# 115

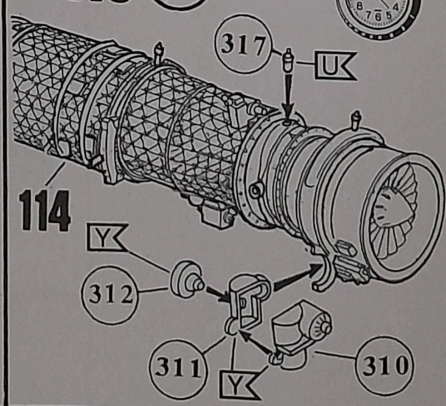

# 116

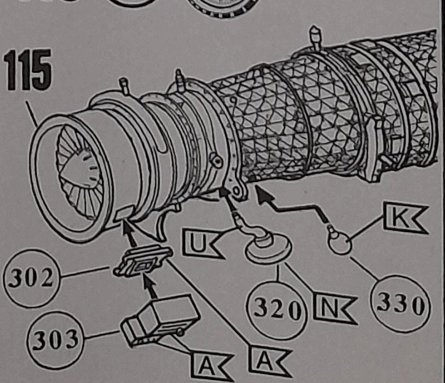



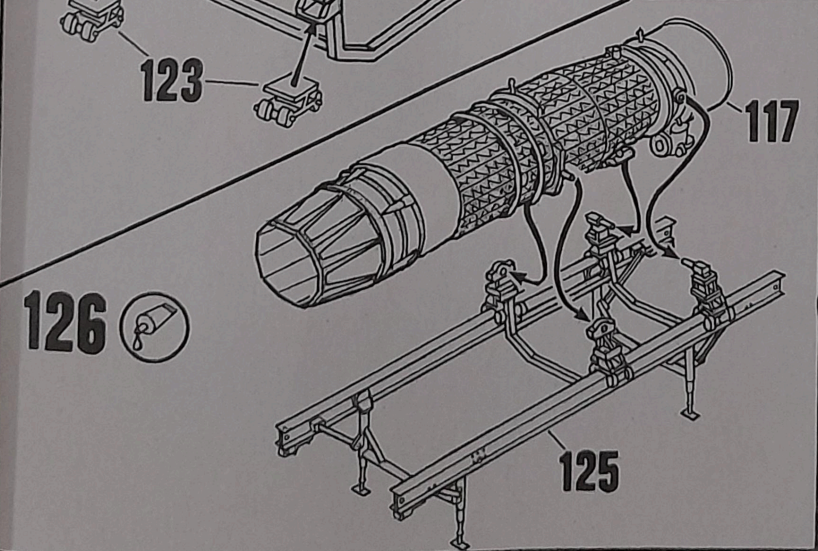
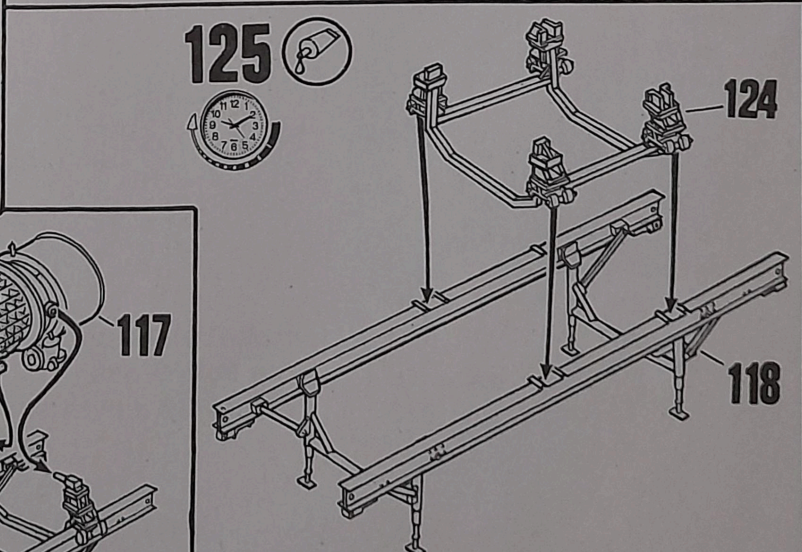
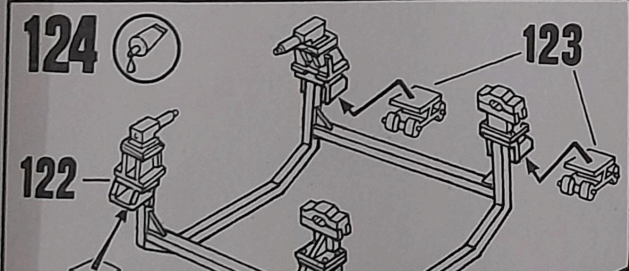
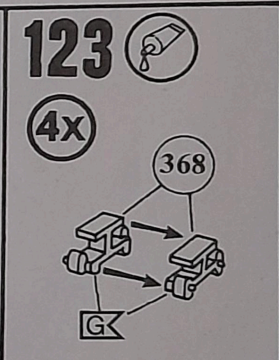
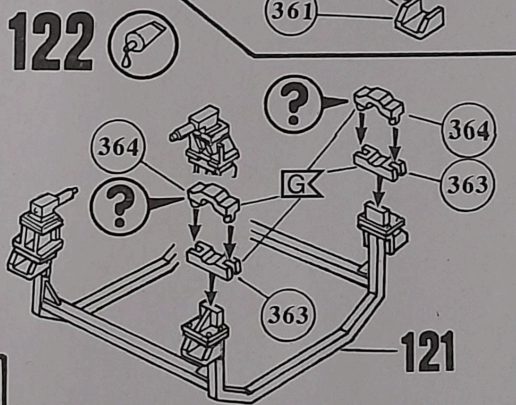
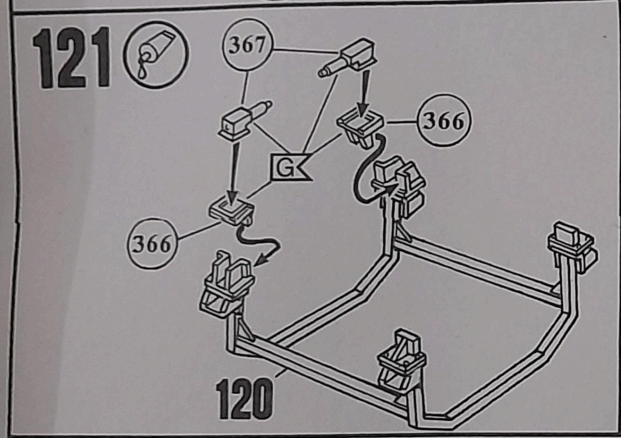
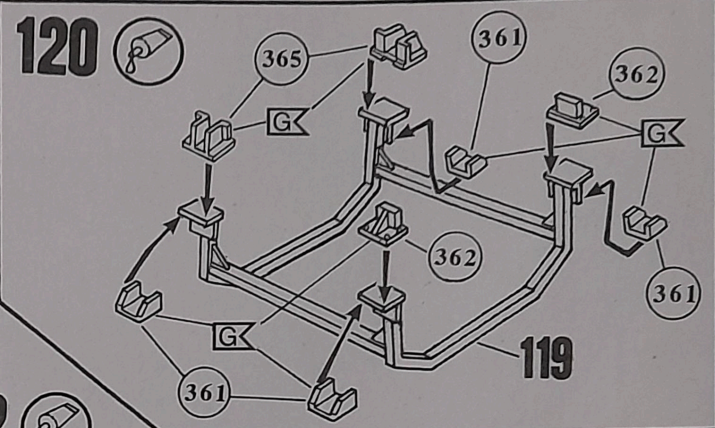
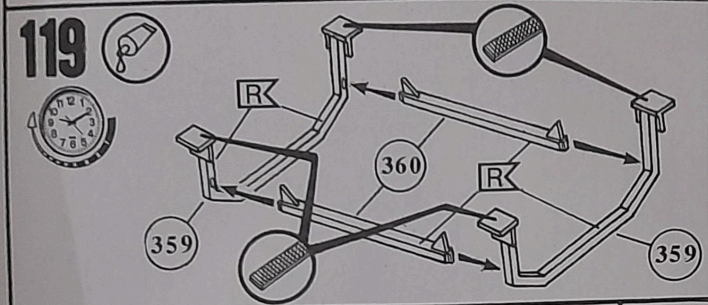
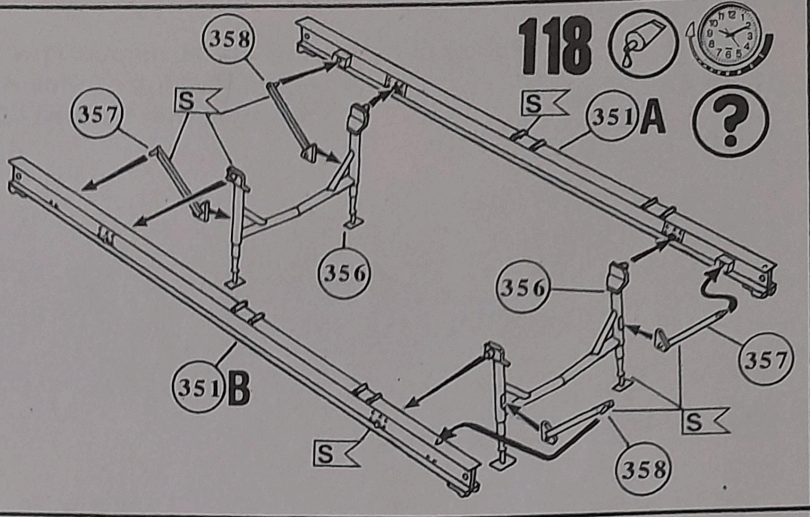
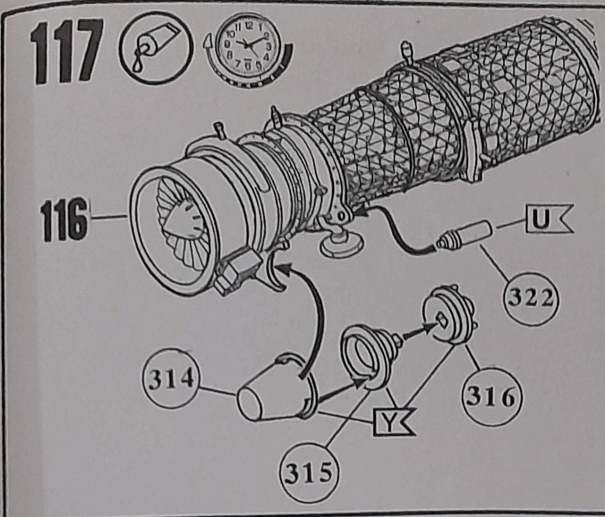

# 127

Eurofighter of German Air Force Jagdgeschwader 74 "Mölders", Neuburg, 2009;  
with Special Marking commemorate 10 000 Hours  
Flighttime with German Luftwaffe Units

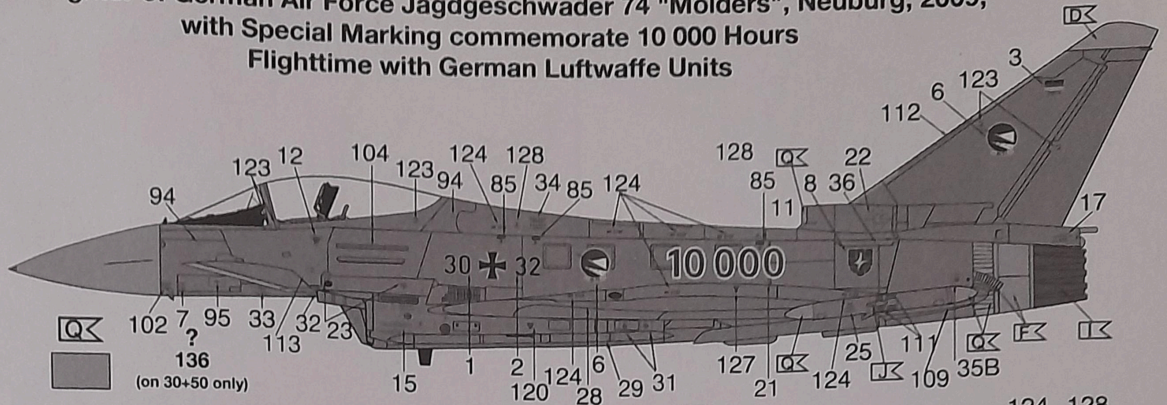
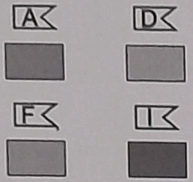
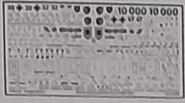

136  
(on 30+50 only)

Alternative Markings  
2. Version

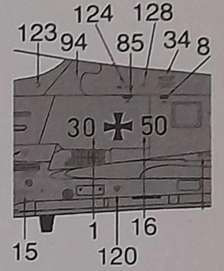
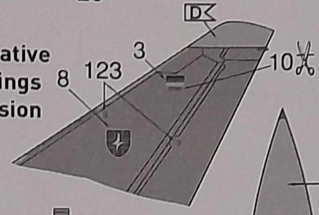

Alternative Markings  
2. Version

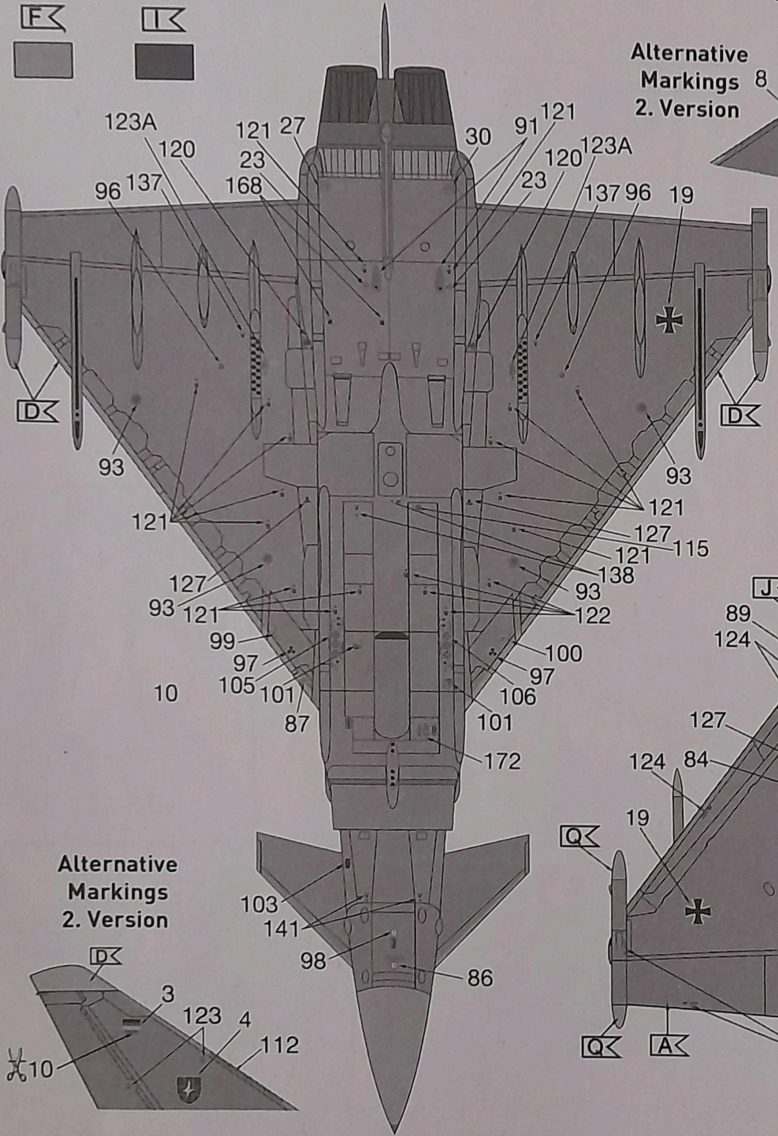

Alternative Markings  
2. Version

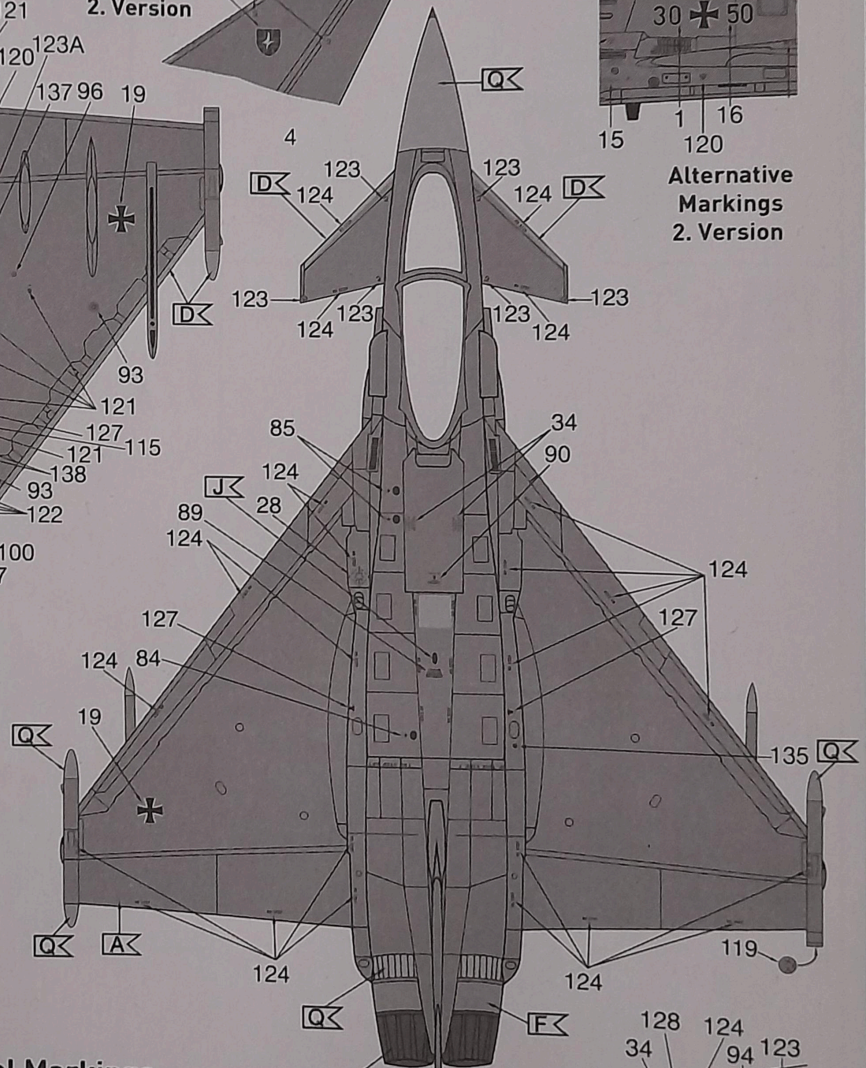
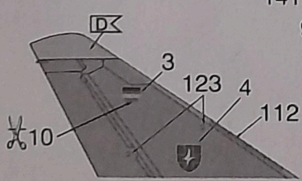

Special Markings  
on both Sides  
( of 30 + 32 only! )

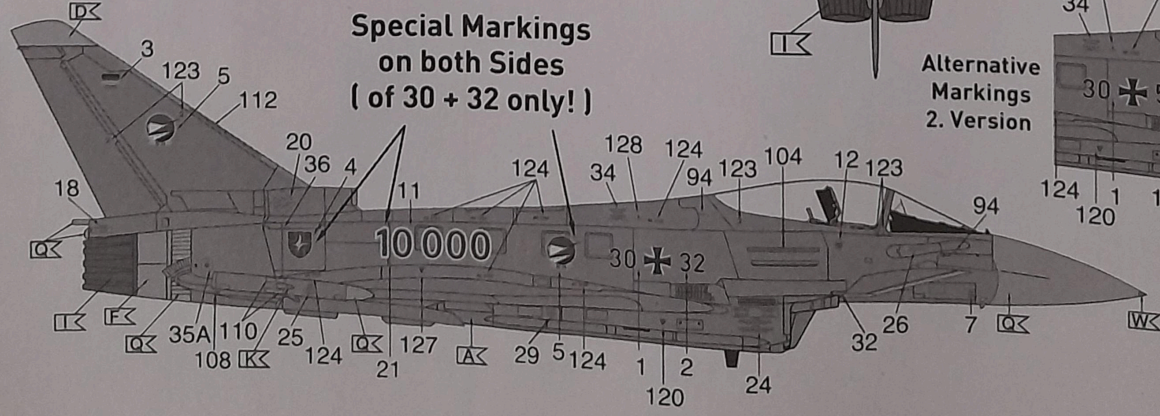

Alternative Markings  
2. Version

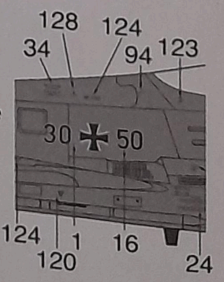

# Eurofighter Typhoon F.2 of No. 11 Squadron Royal Air Force; RAF Coningsby, Lincolnshire 2009

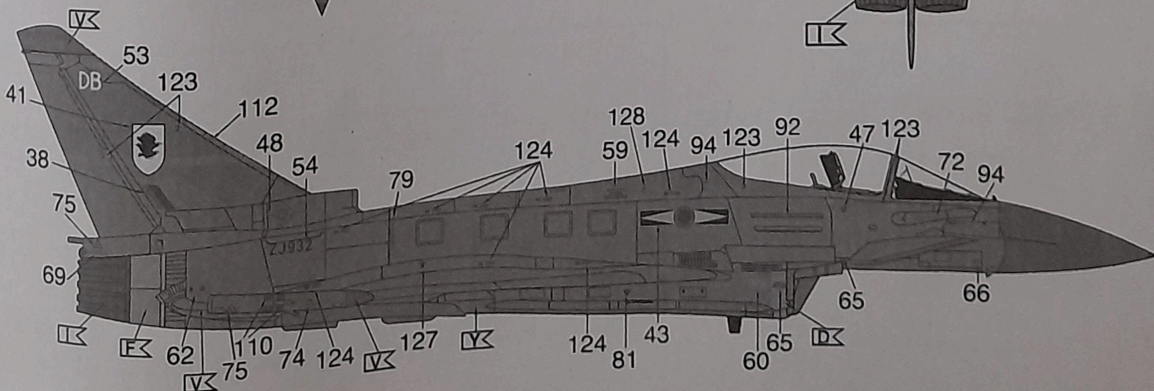
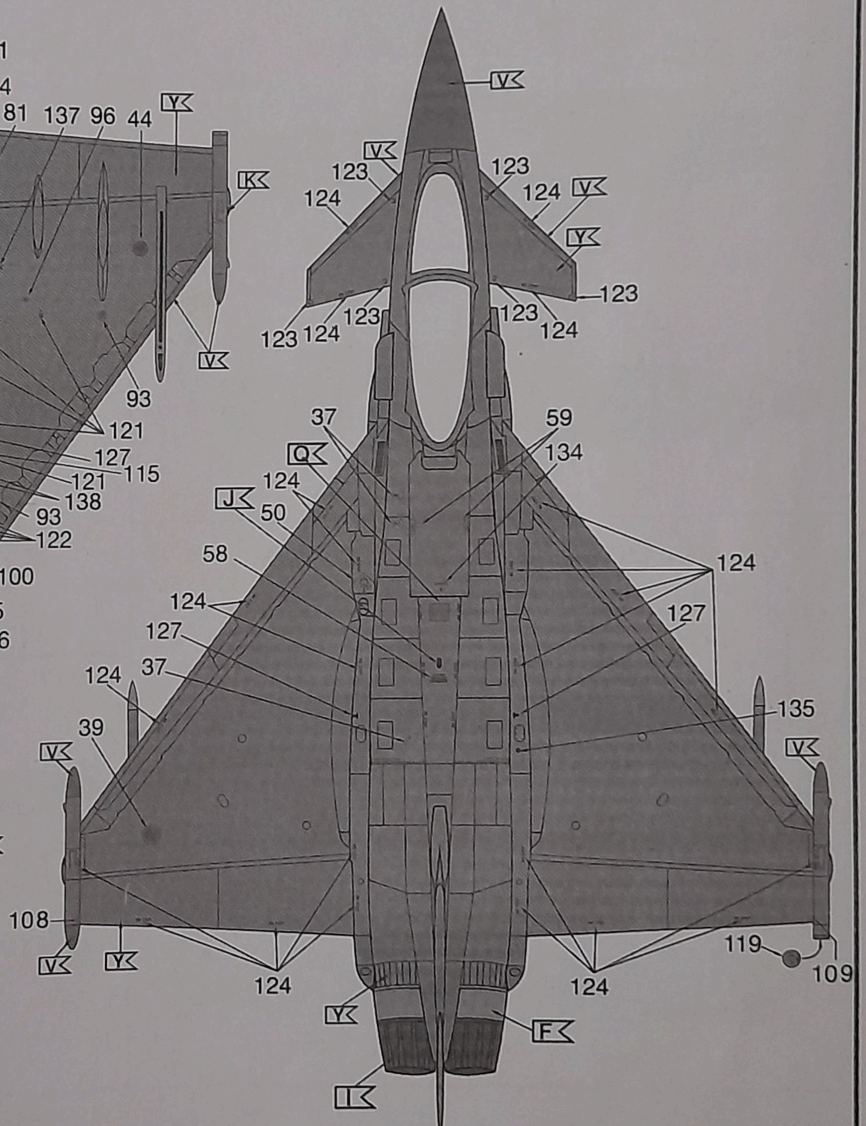
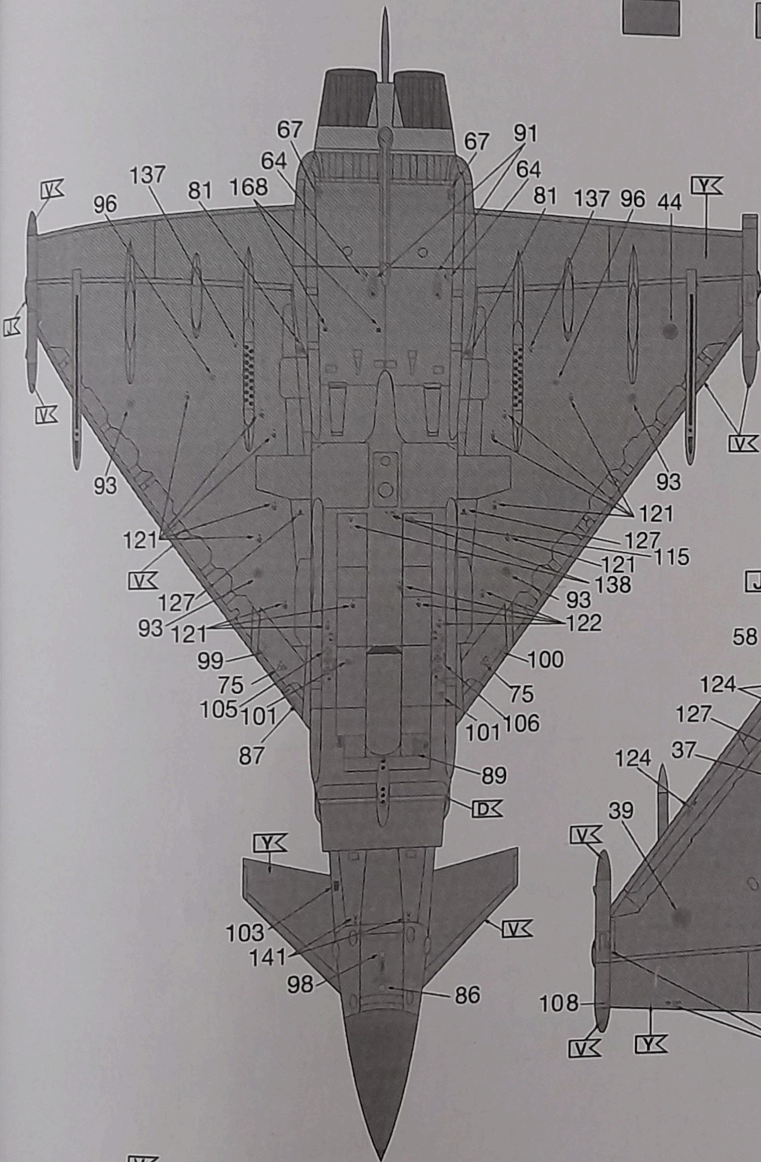
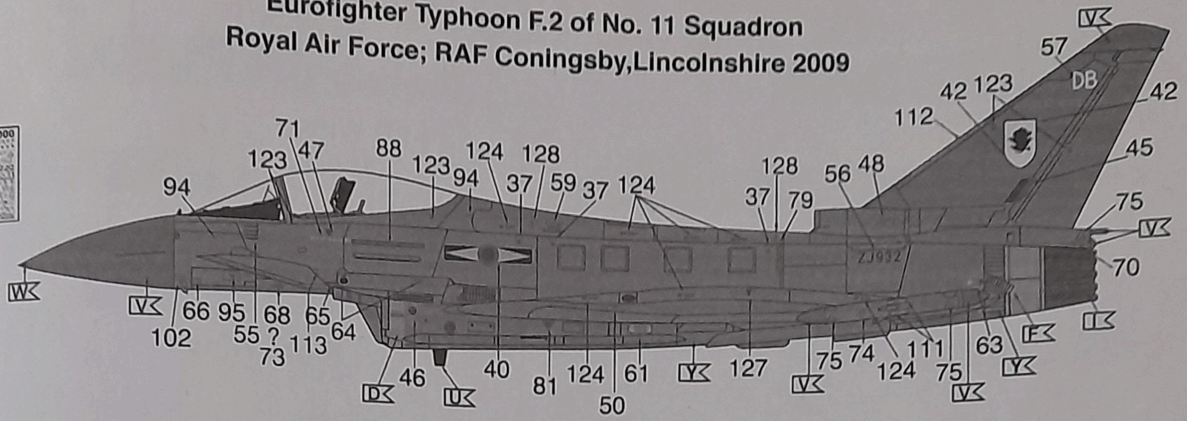
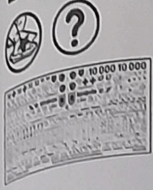

2 x

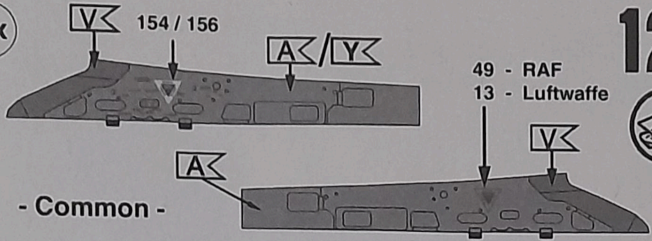

- Common -

129

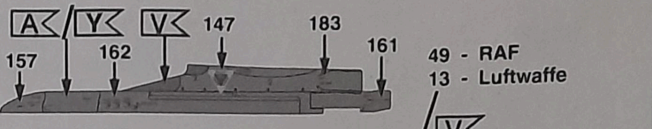

- Left Wing -

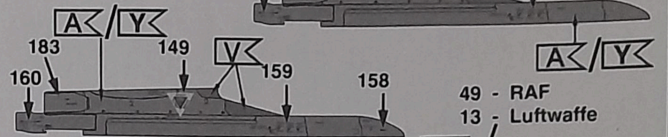

- Right Wing -

- Pylon with IRIS-T Launcher -

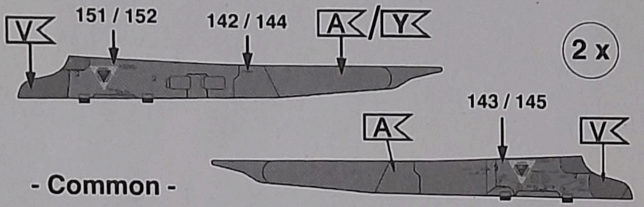

- Common -

2 x

- 1000 Ltr Fuel Tanks - German Air Force

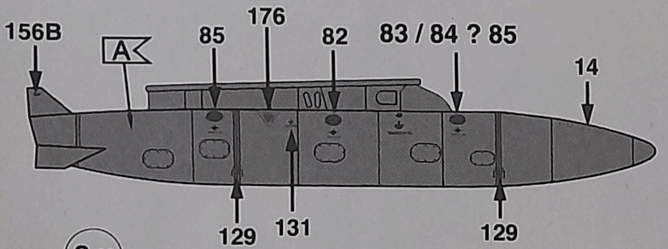

2 x

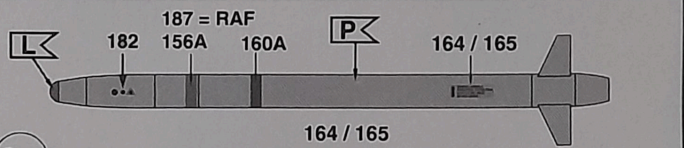

2 x

- AIM-132 ASRAAM -

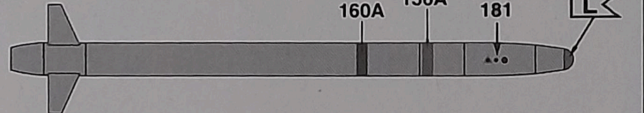

- 1000 Ltr Fuel Tanks - Royal Air Force

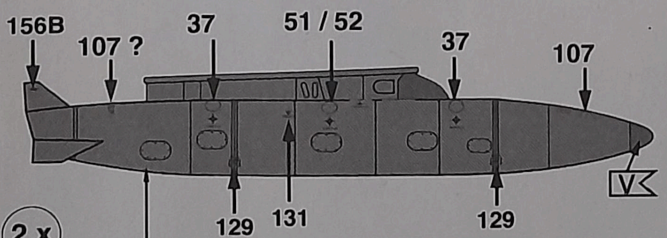

2 x

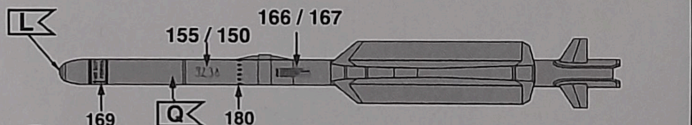

2 x

- IRIS - T -

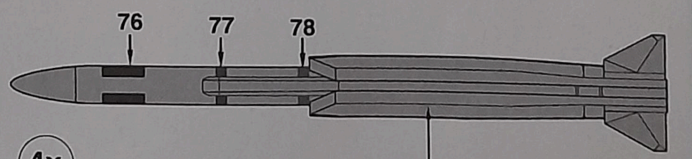
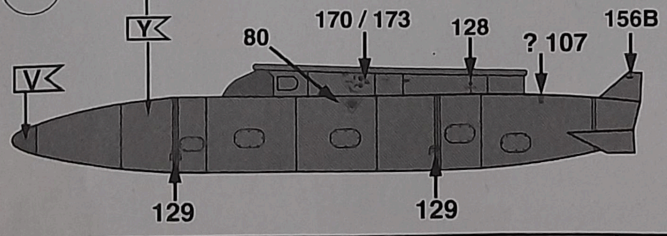
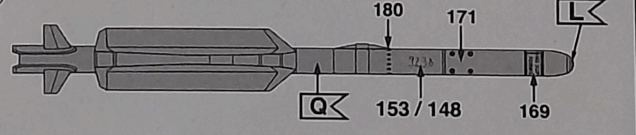

4 x

- Meteor -

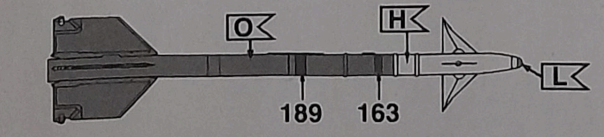

2 x

- AIM-9L Sidewinder -

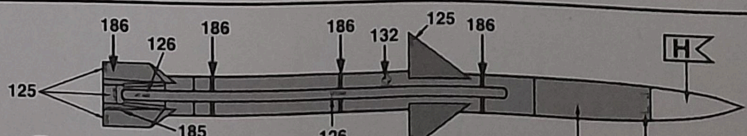

4 x

- AIM-120B AMRAAM -

