

H-252

ASSEMBLY INSTRUCTIONS

THE SCALE OF
THIS MODEL IS
1/91 ACTUAL SIZE
OR
1" = 7' 5"



Made in Germany by Revell Plastics GmbH, 498 Bünde

B-58 HUSTLER

INTERESTING FACTS ABOUT YOUR CONVAIR B-58 HUSTLER

Packing a big punch in a small package, CONVAIR'S delta-winged B-58 is the most fantastic long-range bomber to take the air. Many years in the planning stages, and taking many of its design features from its highly successful smaller brother, the F-102, the HUSTLER is expected to become America's first line long-range bomber.

Although most information about this aircraft is top secret, it is known to have a wingspan of 55 feet, and an overall length of about 95 feet. It has admittedly flown over 1500 miles per hour, but no official top speed has been announced. As part of the United States participation in the 24th International Aeronautical Show, a B-58 flew from New York to Paris in 3 hours, 19 minutes and 41 seconds.

It is powered with four General Electric J79 turbojets, each having a thrust rating of 12,000 pounds. With afterburners installed, this rating can be boosted appreciably. Perhaps the most interesting feature of this aircraft is the method in which it carries

its tactical cargo. A series of external pods have been designed, and in these the HUSTLER can carry a variety of equipment, ranging from extra fuel, photo reconnaissance systems, to nuclear weapons.

The standard crew consists of three: a pilot, a navigator-bombardier, and a defensive systems operator. A pressurization and air conditioning system is designed into the aircraft, and controls the heating, pressurization and dehumidification of the cabin air, as well as defogging the windshield, and keeping the cockpit temperatures low.

Among the other features included in the HUSTLER'S design is the "area rule" or "wasp waist" fuselage. This, along with a "conical camber" leading edge, and a completely new "honeycomb" wing construction has made the B-58 the most spectacular bomber to join United States Air Force.

FOR BEST RESULTS, READ THIS FIRST

1. Since this kit is molded of Styrene Plastic, use only Revell Type [®] Cement. Do not let cement touch your eyes, furniture or clothing.
2. Apply cement sparingly. Excess cement may run and damage the details on your model.
3. Carefully trim any excess plastic from parts before assembling. This will result in parts fitting together

perfectly, and also enable any moving parts to move freely. **THIS IS VERY IMPORTANT**

4. With Revell Paint Set Colors, paint all the details where indicated and allow to dry before assembling. All colors are Flagged as shown: WHITE
5. All parts are numbered for easy identification, or the numbers are engraved on the bar next to the part. Carefully remove each part from its bar only when that part is to be used.

6. Start with part No. 1 and cement it to No. 2, etc. Take your time — do not RUSH.
7. Directions for applying your decals are on the back of the decal sheet.
8. Follow these easy to assemble steps. Start with STEP 1.

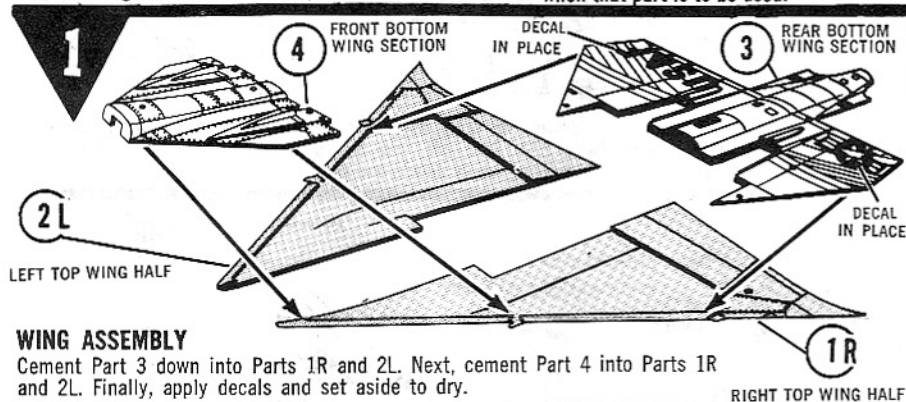

WING ASSEMBLY

Cement Part 3 down into Parts 1R and 2L. Next, cement Part 4 into Parts 1R and 2L. Finally, apply decals and set aside to dry.

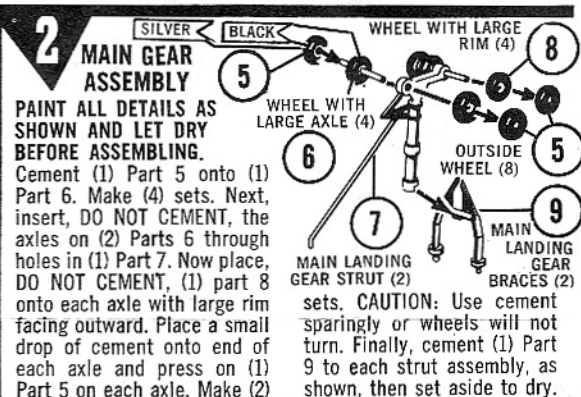

2 MAIN GEAR ASSEMBLY

PAINT ALL DETAILS AS SHOWN AND LET DRY BEFORE ASSEMBLING.

Cement (1) Part 5 onto (1) Part 6. Make (4) sets. Next, insert, DO NOT CEMENT, the axles on (2) Parts 6 through holes in (1) Part 7. Now place, DO NOT CEMENT, (1) part 8 onto each axle with large rim facing outward. Place a small drop of cement onto end of each axle and press on (1) Part 5 on each axle. Make (2)

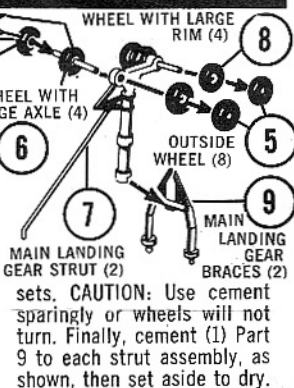

FUSELAGE ASSEMBLY

Cement Parts 10, 12 and 13 down onto Part 11, then cement this assembly into Part 14R. Apply cement sparingly to edges of Part 15L and press onto Part 14R. Use rubber bands to hold Fuselage halves until dry. Finally, apply decals and set aside to dry.

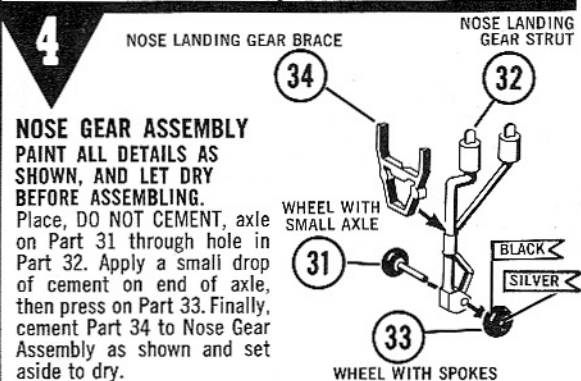

4 NOSE GEAR ASSEMBLY

PAINT ALL DETAILS AS SHOWN, AND LET DRY BEFORE ASSEMBLING.

Place, DO NOT CEMENT, axle on Part 31 through hole in Part 32. Apply a small drop of cement on end of axle, then press on Part 33. Finally, cement Part 34 to Nose Gear Assembly as shown and set aside to dry.

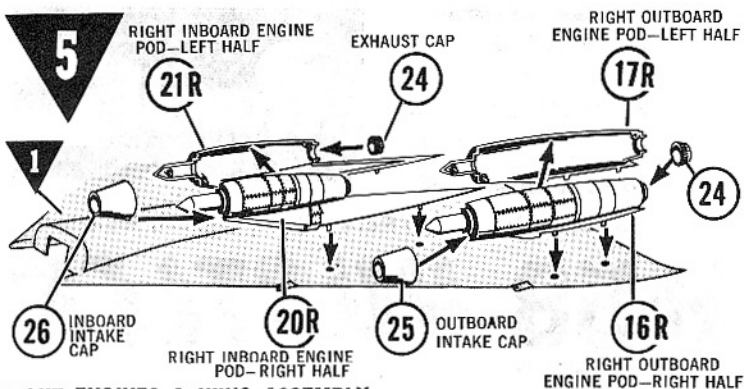

RIGHT ENGINES & WING ASSEMBLY

Cement Parts 16R and 17R together, then cement (1) Part 24 to rear and (1) Part 25 to front. Cement assembled engine into assembly 1 as shown. Next, cement Parts 20R and 21R together, then cement (1) Part 24 to rear and (1) Part 26 to front. Finally, cement completed engine into Assembly 1 and set aside to dry.

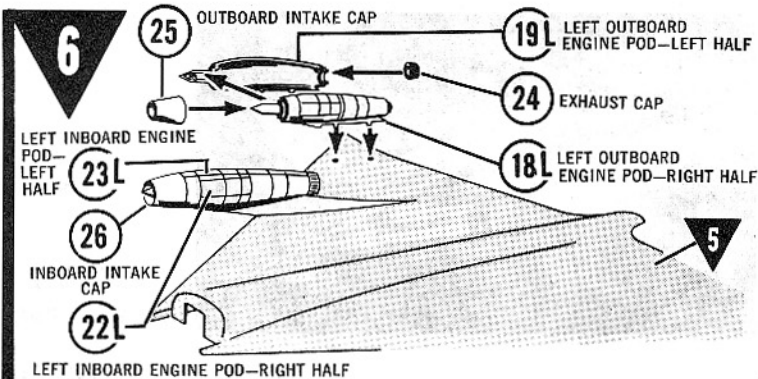

LEFT ENGINES AND WING ASSEMBLY

Cement Parts 18L and 19L together, then cement (1) Part 24 to rear and remaining Part 25 to front. Cement completed engine onto Assembly 5 as shown. Next, cement Parts 22L and 23L together, then cement remaining Parts 24 and 26 to rear and front. Finally, cement completed engine onto Assembly 5 and set aside to dry.

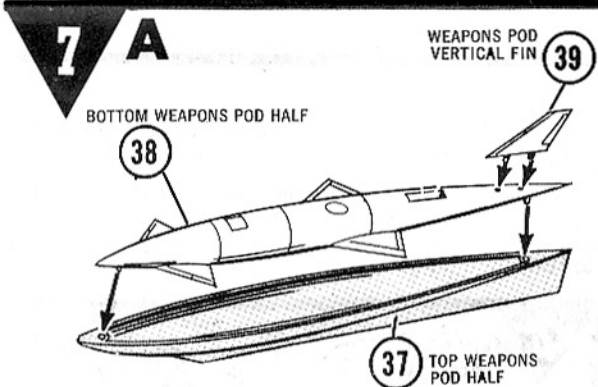

MAIN LANDING GEAR & WEAPONS POD TO WING ASSEMBLY

SEE DRAWING "A". Cement Parts 37 and 38 together. Next, cement Parts 39 and 47 onto Part 38 as shown. Set aside to dry. SEE MAIN DRAWING. Cement

(2) Assemblies 2 down into Wing as shown. Left Main Gear shown in place. Next, cement Parts 27R, 28R, 29L and 30L down onto assembly 6. Finally, cement Assembly A to Wing, apply decals and set aside to dry.

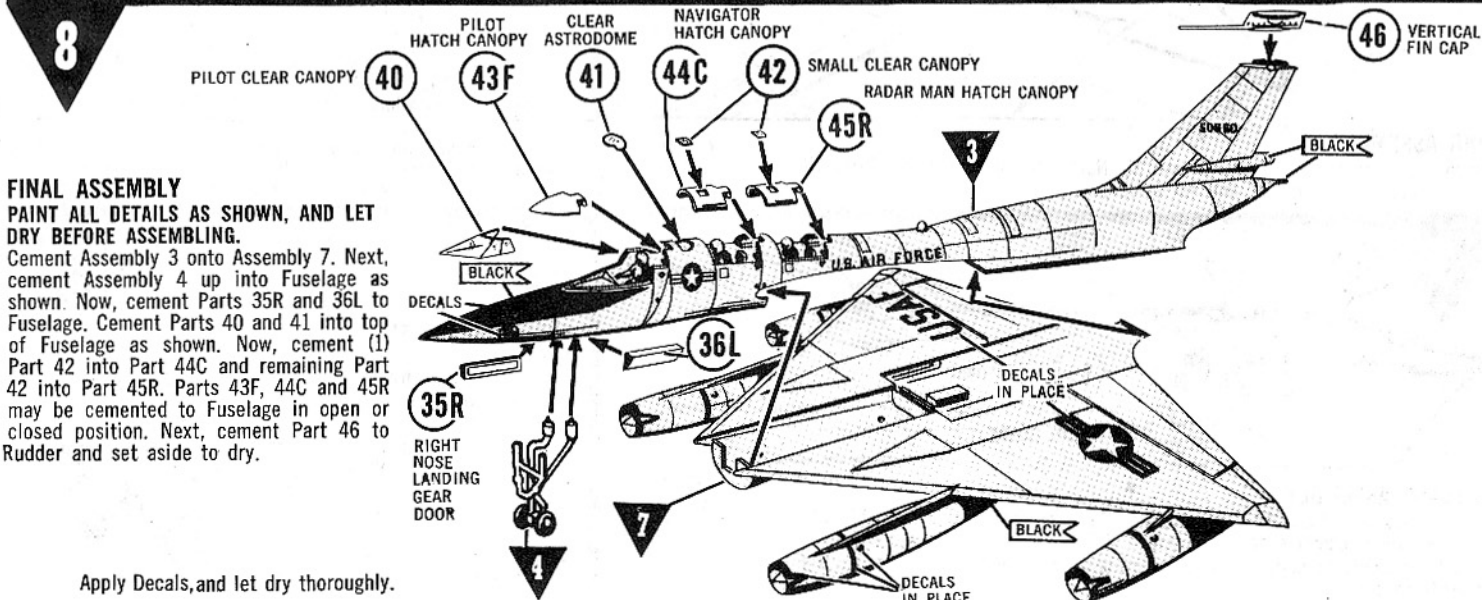

FINAL ASSEMBLY

PAINT ALL DETAILS AS SHOWN, AND LET DRY BEFORE ASSEMBLING.

Cement Assembly 3 onto Assembly 7. Next, cement Assembly 4 up into Fuselage as shown. Now, cement Parts 35R and 36L to Fuselage. Cement Parts 40 and 41 into top of Fuselage as shown. Now, cement (1) Part 42 into Part 44C and remaining Part 42 into Part 45R. Parts 43F, 44C and 45R may be cemented to Fuselage in open or closed position. Next, cement Part 46 to Rudder and set aside to dry.

Apply Decals, and let dry thoroughly.

B-58 HUSTLER 4354-4300



U.S. AIR FORCE

U.S. AIR FORCE

USAF USAF

WARNING
FLASH POINT
JET FUEL
AP TO-9003

LT.

RT.

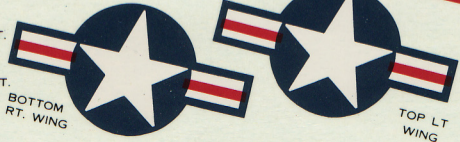

BOTTOM
RT. WING

TOP LT
WING

NO STEP NO STEP
NO STEP NO STEP
NO STEP NO STEP

LT. FUS.

RT. FUS.

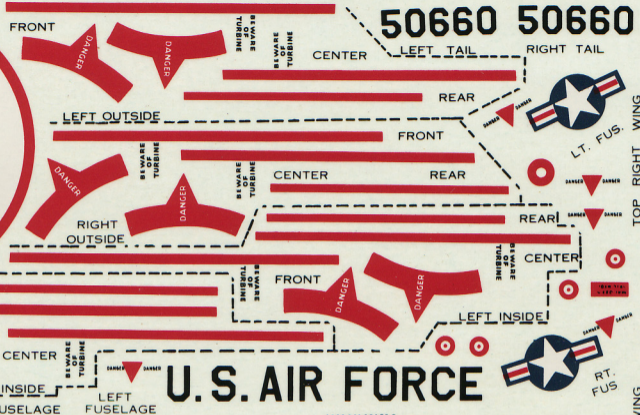
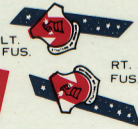

50660 50660

WALK WAY
NO STEP

TOP LEFT WING

NOSE

TOP RIGHT WING
BOTTOM LEFT WING