

1/48 Scale

SW 48008

EE (BAC) Lightning T.4



In 1947 the Ministry of Supply issued Experimental Requirement 103 for a manned research aircraft capable of exploring transsonic and supersonic speeds.

English Electric and Fairey Aviation submitted proposals, the former being designated the P.1 designed initially by W.E.W. "Teddy" Petter.

Fairey Aviation submitted proposal too in the design of the FD.2.

Design performance had been set to a maximum speed of Mach 1.5 at a height of 30,000'.

Lightning P1 - The ER103 design study was sufficiently good to be awarded by Air Ministry Requirement F.23/49 for two prototypes and a structural-test airframe. The requirement differed from E.R.103 in that the design had to incorporate military capabilities.

The design was a quite unorthodox - two engines were mounted on top of each other, the upper being slightly more forward, swept wings,

The first time a time a British aircraft was to go supersonic in level flight was on 11th August 1954. One of these two prototypes - WG760 went transsonic at 30,000 ft, but the event went unrecorded as the flight was too short.

One day later, on 12th August W/C Roland Beamont (who also had experience flying F-86 Sabre) took the aircraft to 38,000' and recorded a speed of Mach 1.02.

The transition was so smooth, it was even unnoticed, the aircraft continued to respond in a normal manner with no apparent difficulty.

There have been other tests and other prototypes, but finally it led to final design. The Lightning finally received its official name on 23 October 1958 at a ceremony which was held at Farnborough.

Lightning have been built in several variants starting F.1, followed by F.1A, F.2 and F.3 and definitive F.6, with responding trainer versions T.4 (based on F.1A) and T.5 (based on F.3).

T.4 and T.5 were two-seaters with pilots seating side by side, having a larger fin and also full armament capabilities like single versions.

Lightning have been also exported to Kuwait and Saudi Arabia.

Service with the RAF had lasted from 1960 until 1988 and now there are still flying Lightnings in private hands.

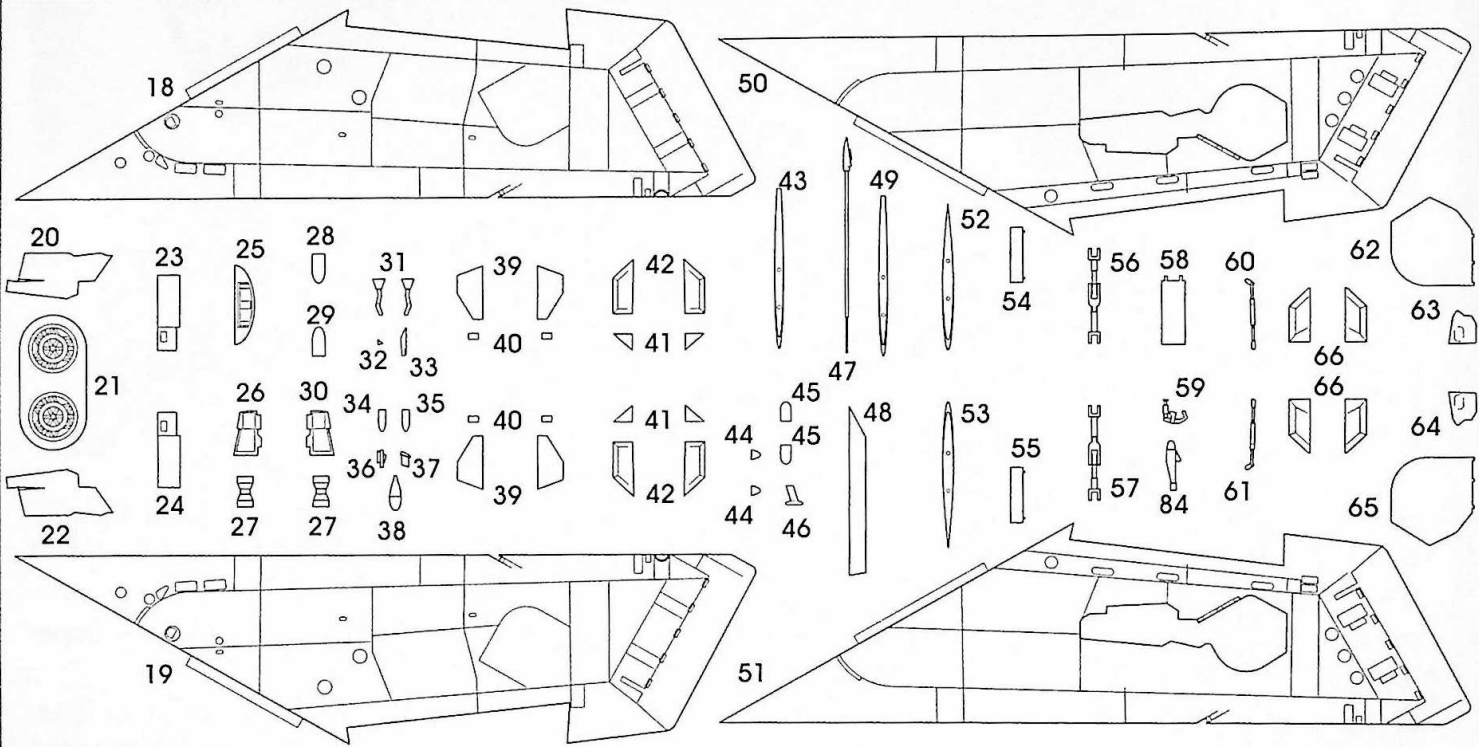
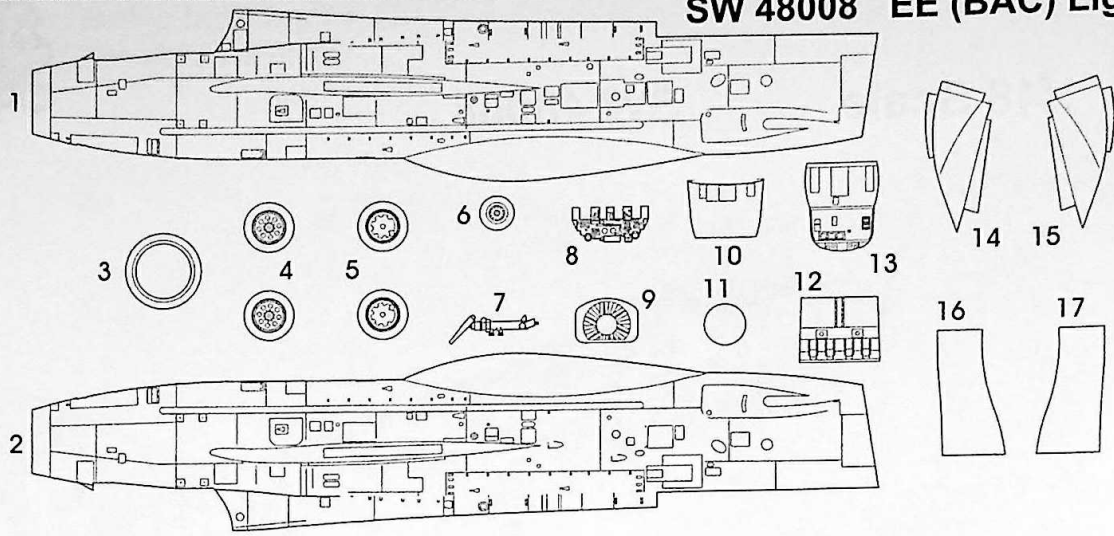
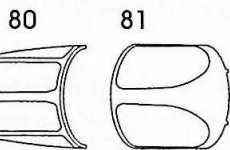
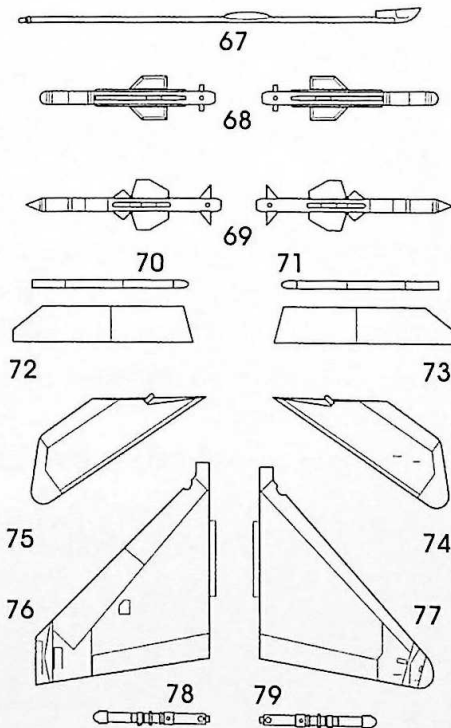
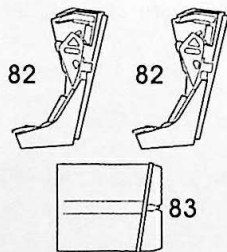

čiré díly/ clear parts

PUR díly/ PUR parts
 Lepit kyanoakrylátovým lepidlem/
 instant cyanoacrylate glue

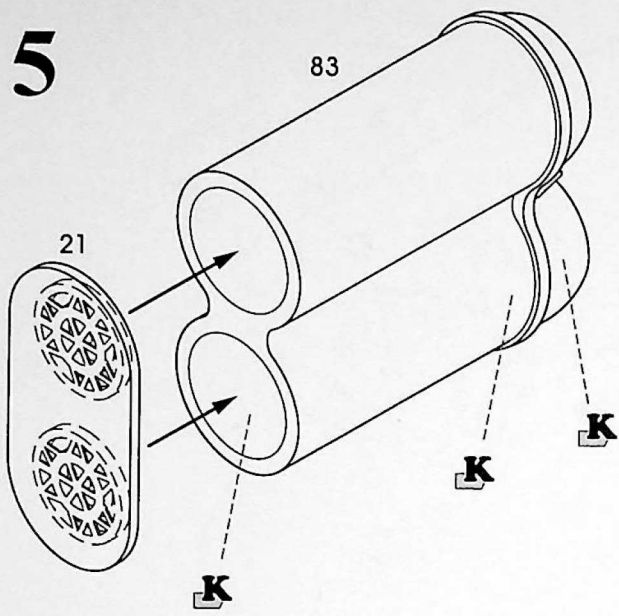
barvy/ colours

- A** — černá / Black
- B** — interiérová černá / Interior Black
- C** — stříbrná / Silver
- D** — hliníková / Aluminium
- E** — červená / Red
- F** — bílá / White
- G** — olivová / Olive
- H** — písková / Sand
- I** — chromová / Chrome
- J** — hnědá / Brown
- K** — kovová tmavá / Gun Metal
- L** — šedá / Gray
- M** — šedočerná / Tyre Black

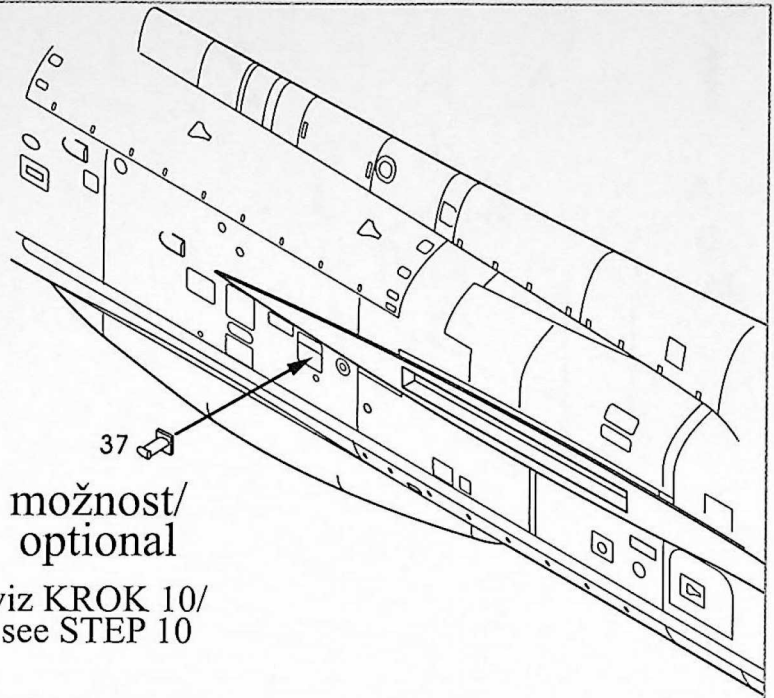
5



6



možnost/
optional
viz KROK 10/
see STEP 10

7

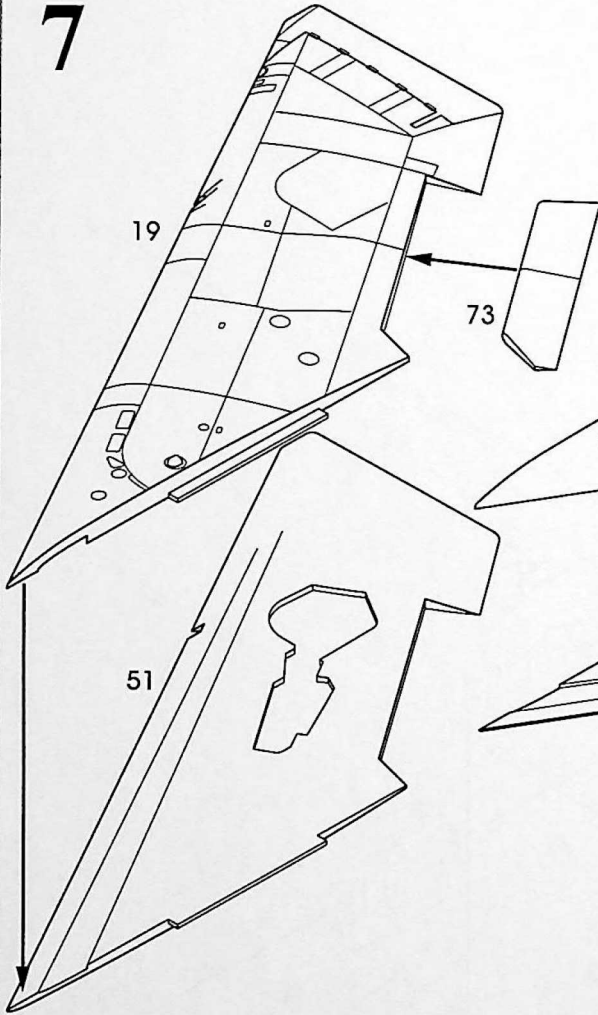

8

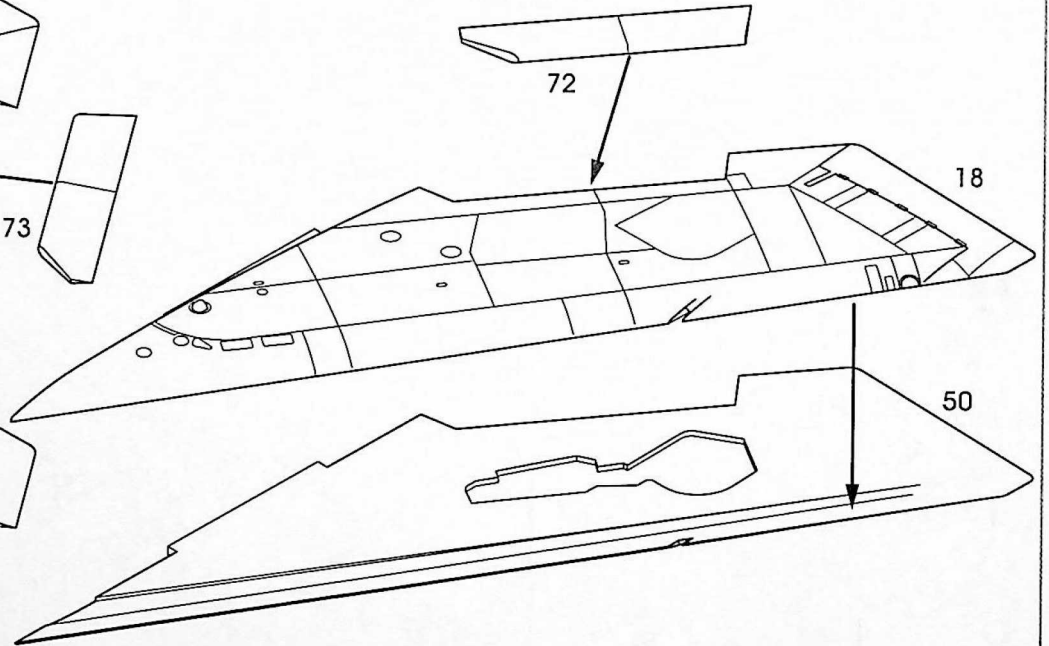

9

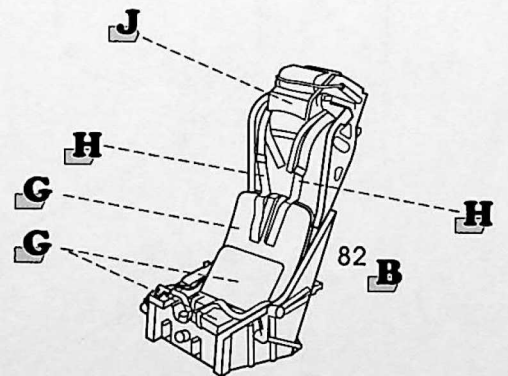

4

10

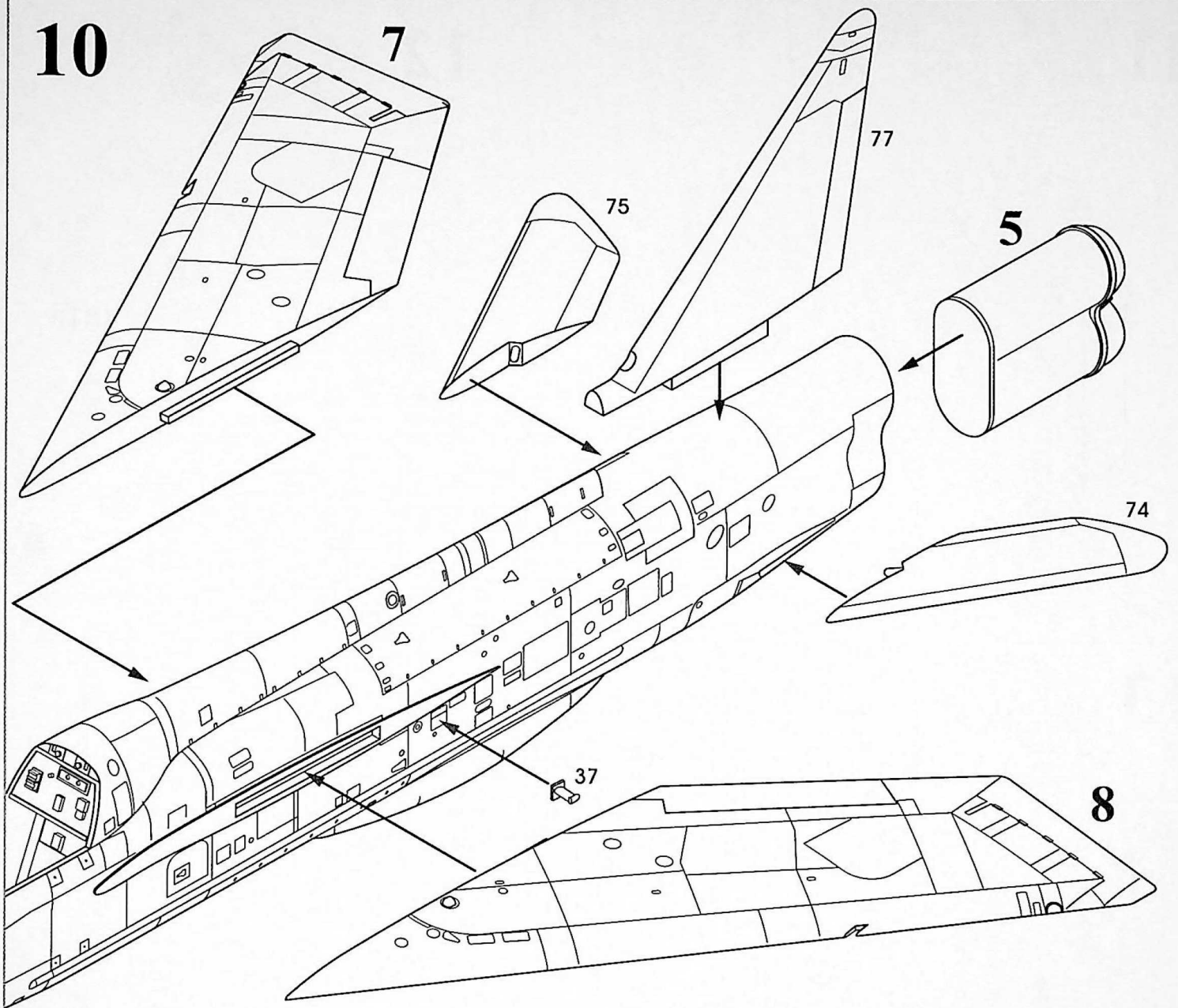

info

úhel vzepětí křídla - 6°
dihedral angle of wings - 6°

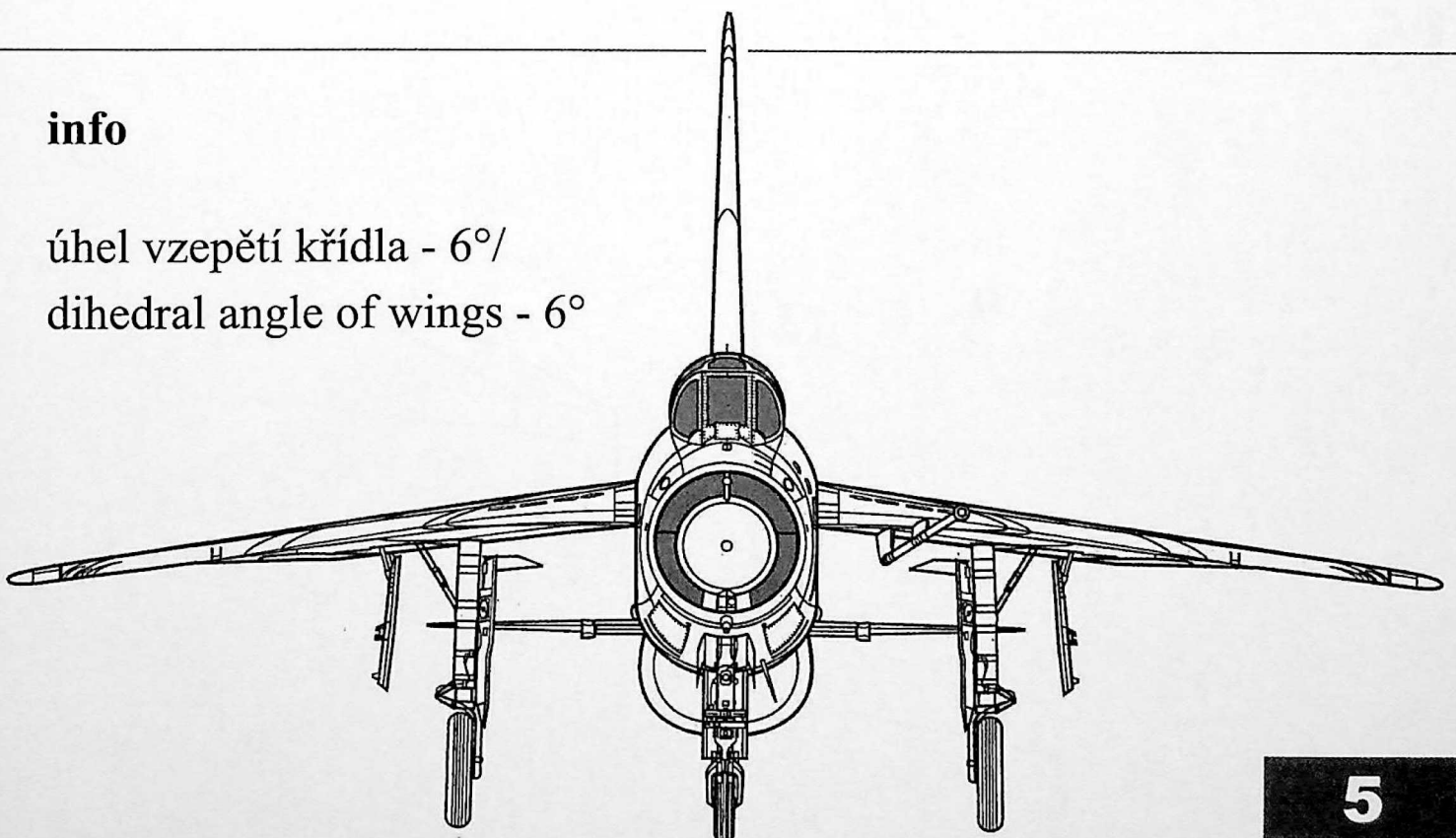

5

11

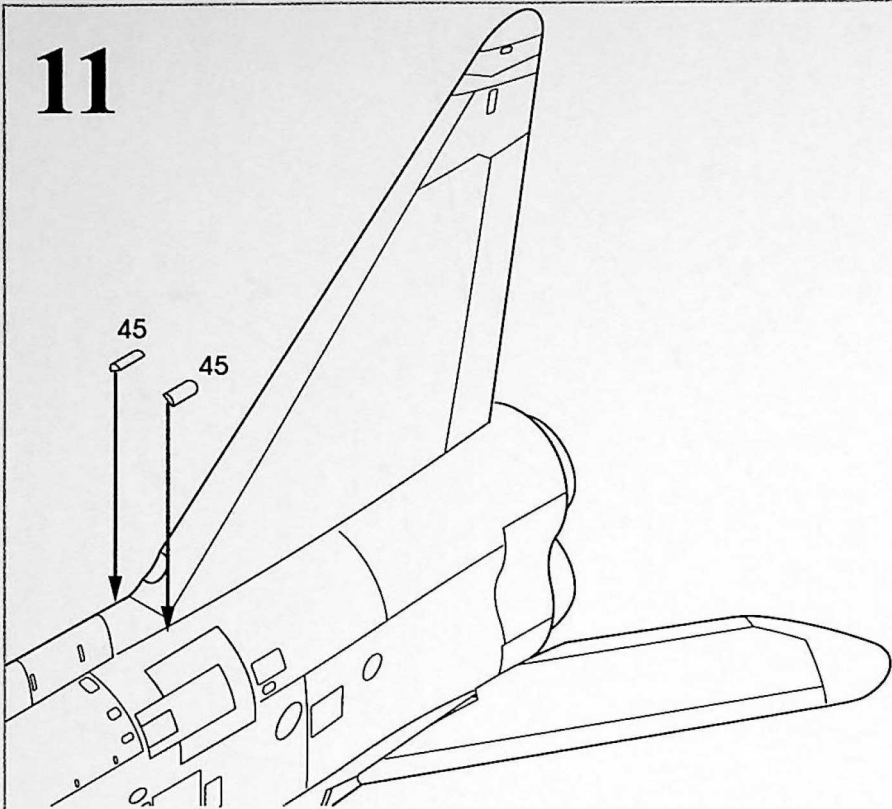

12

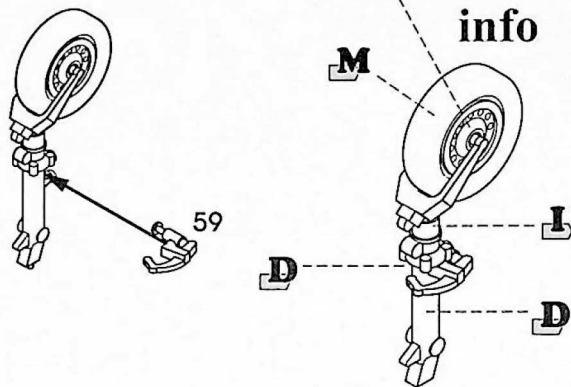
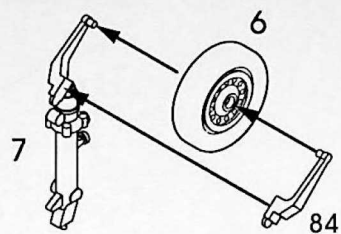

13

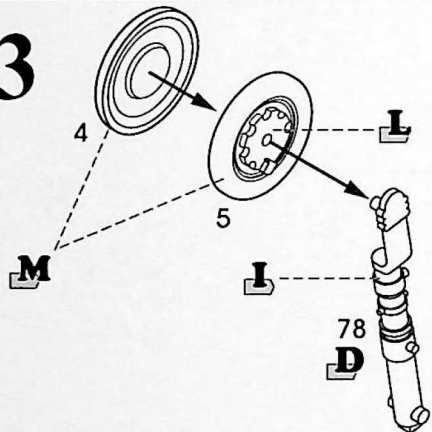

14

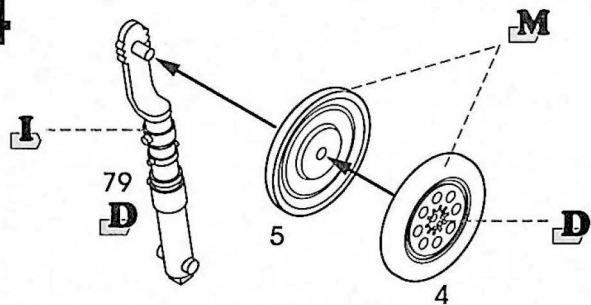

15

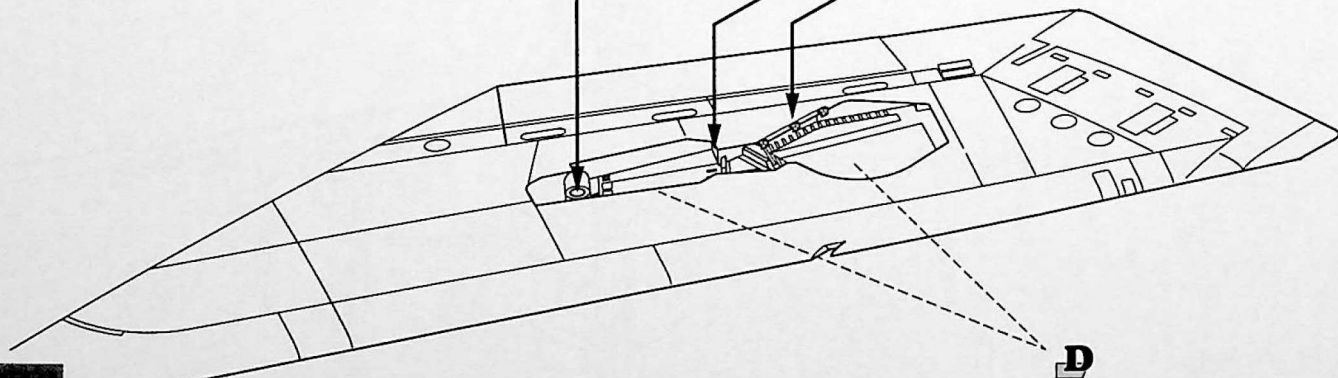
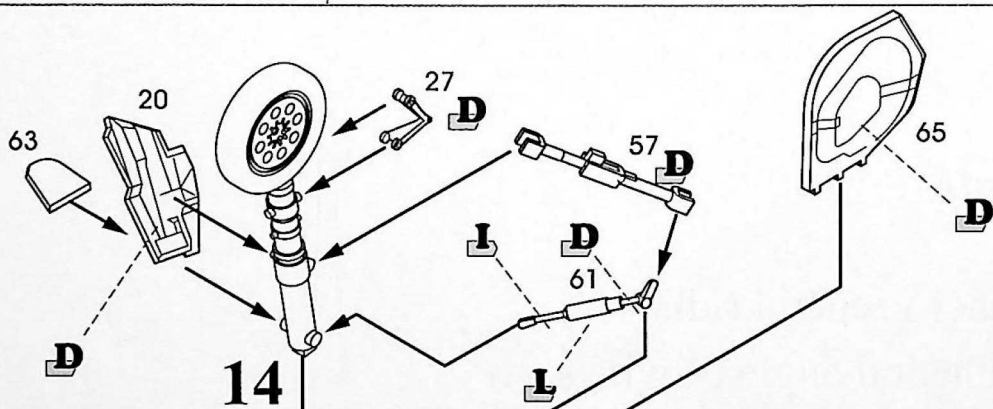

6

16

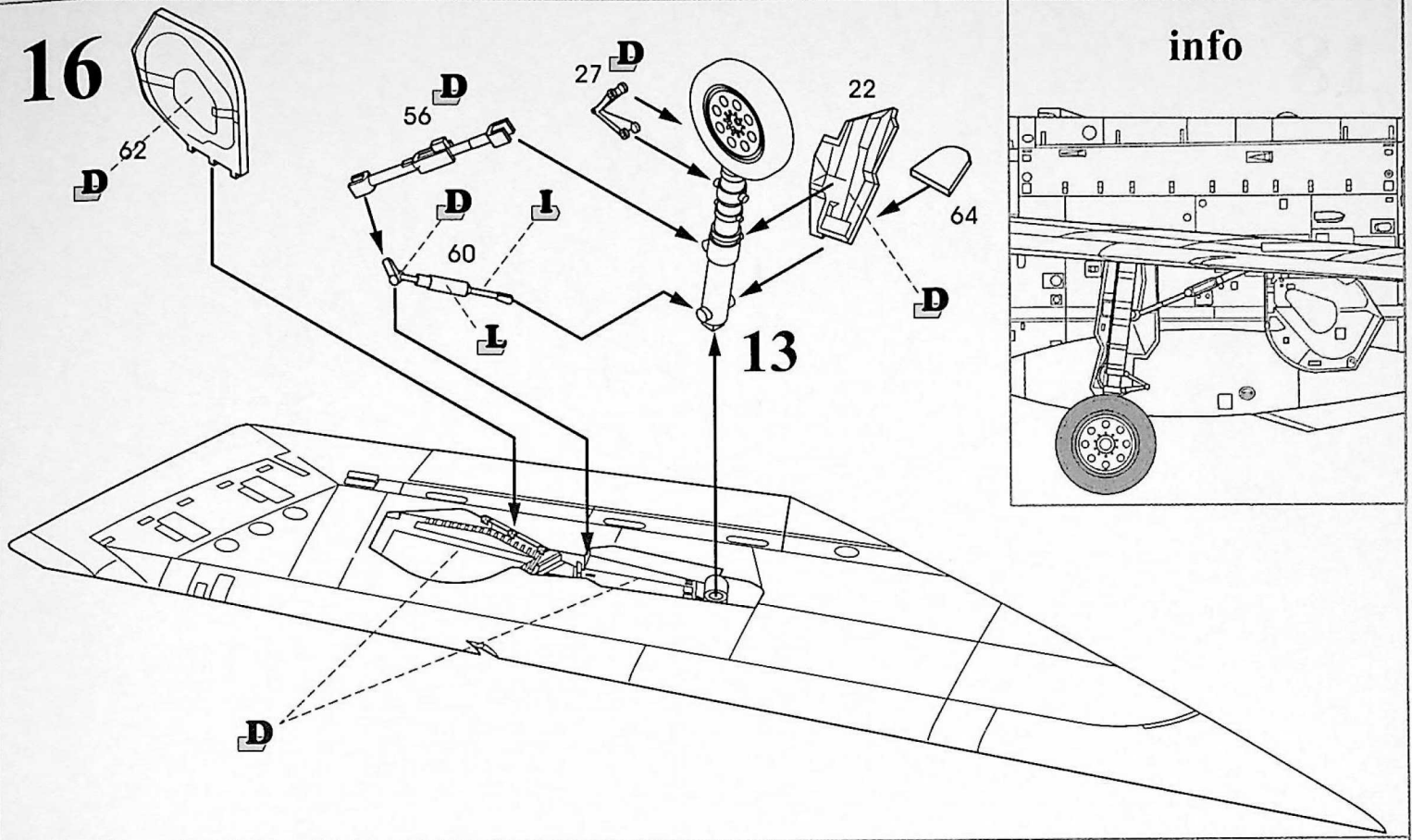

info

17

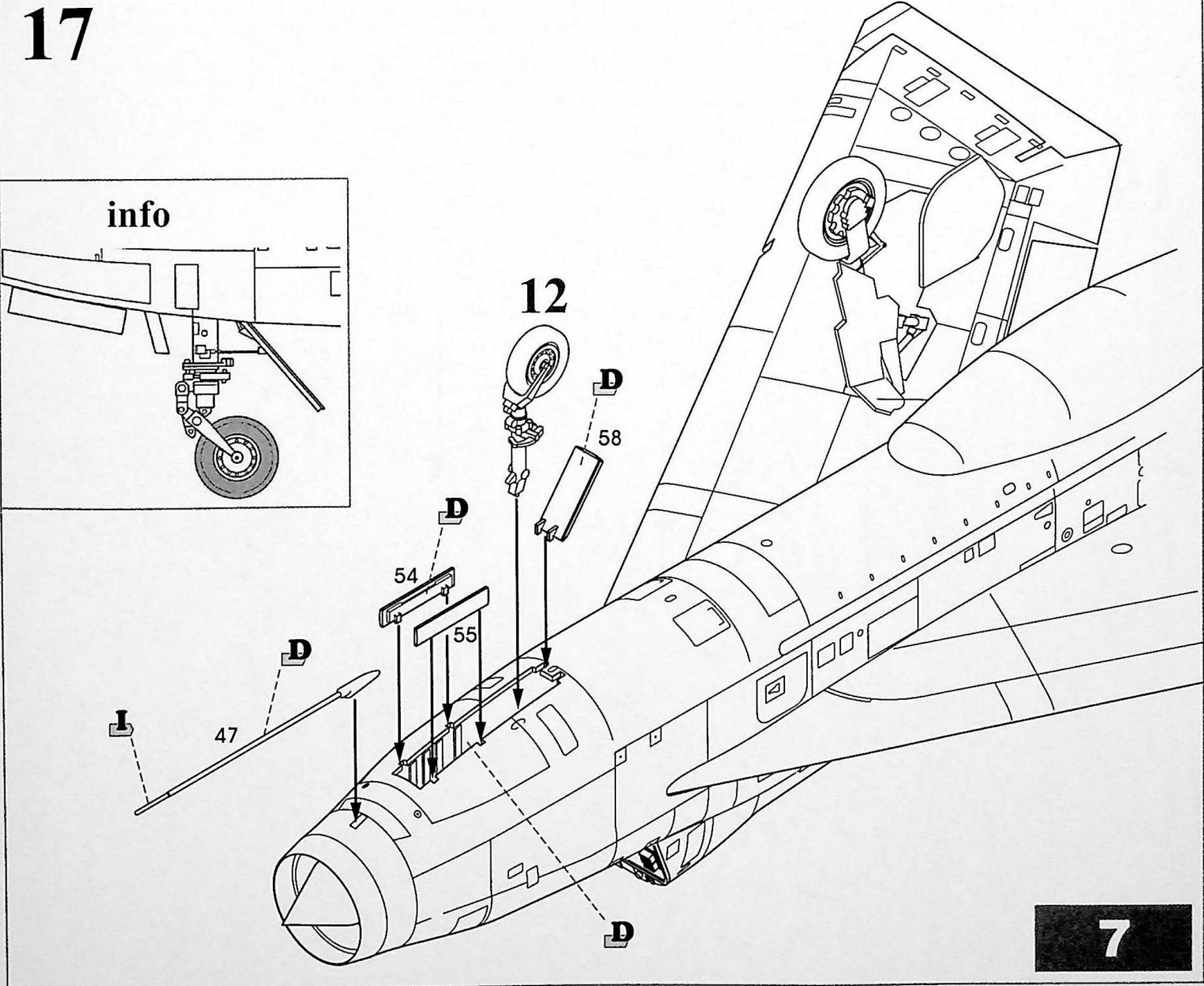

info

18

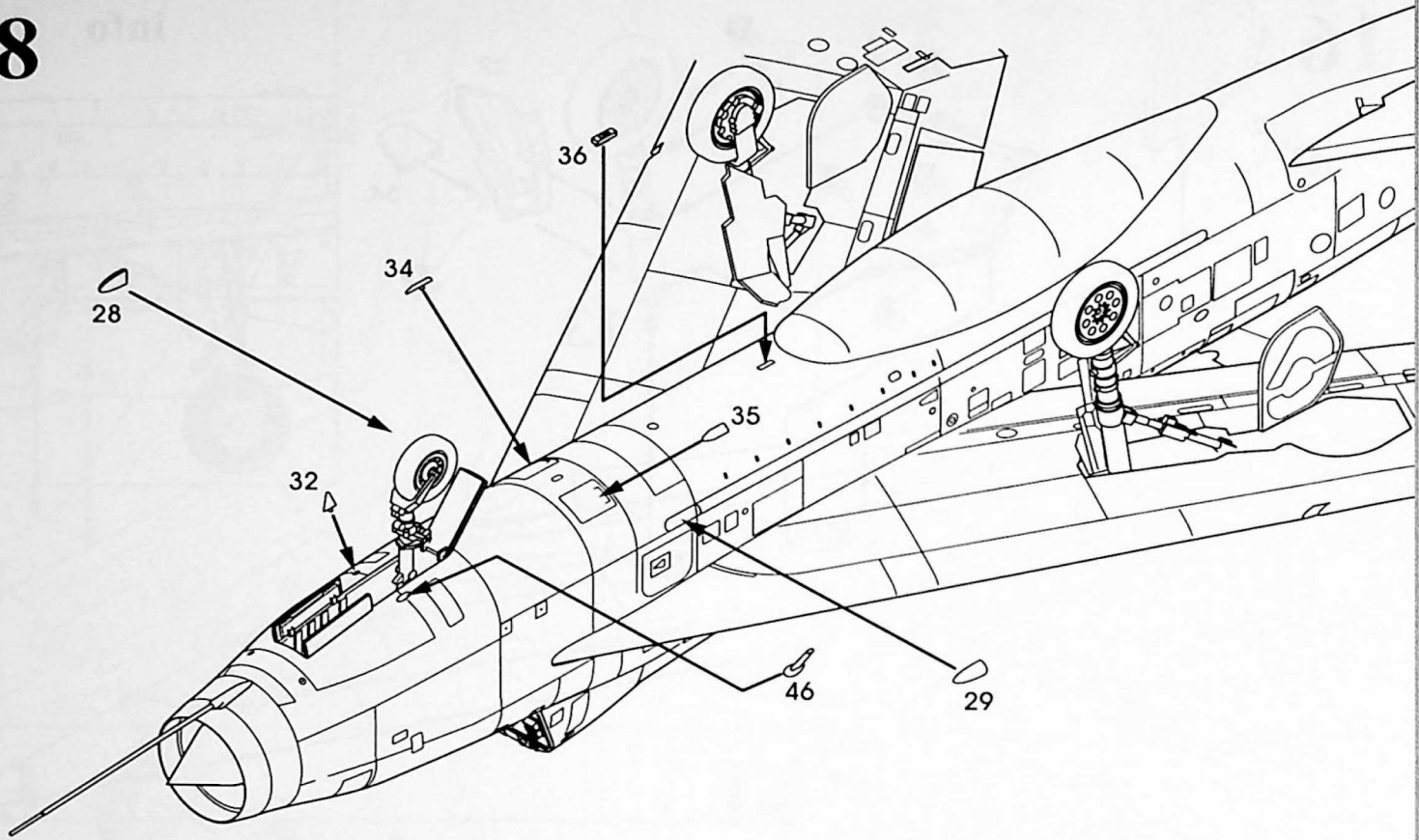

19

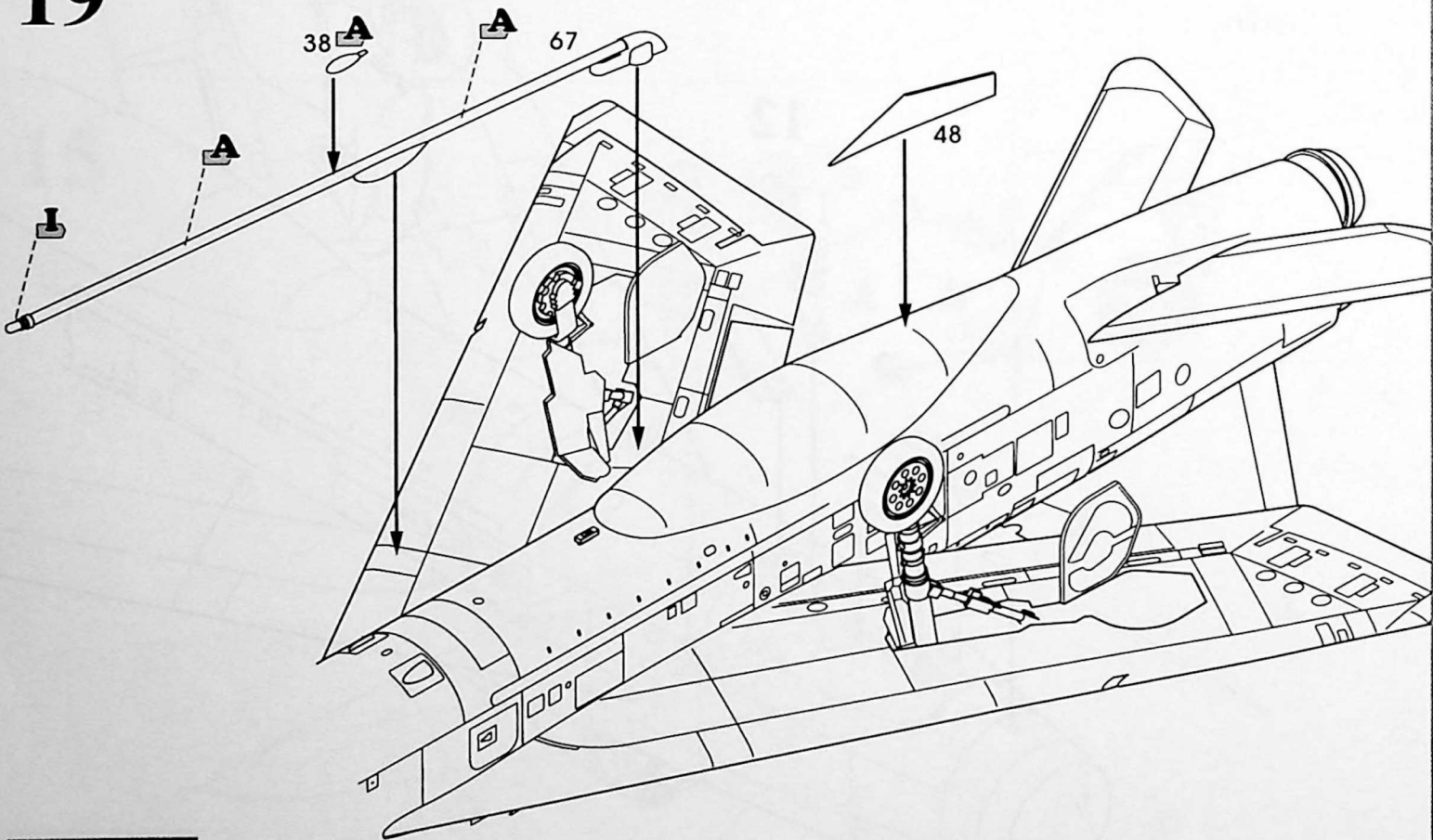

20

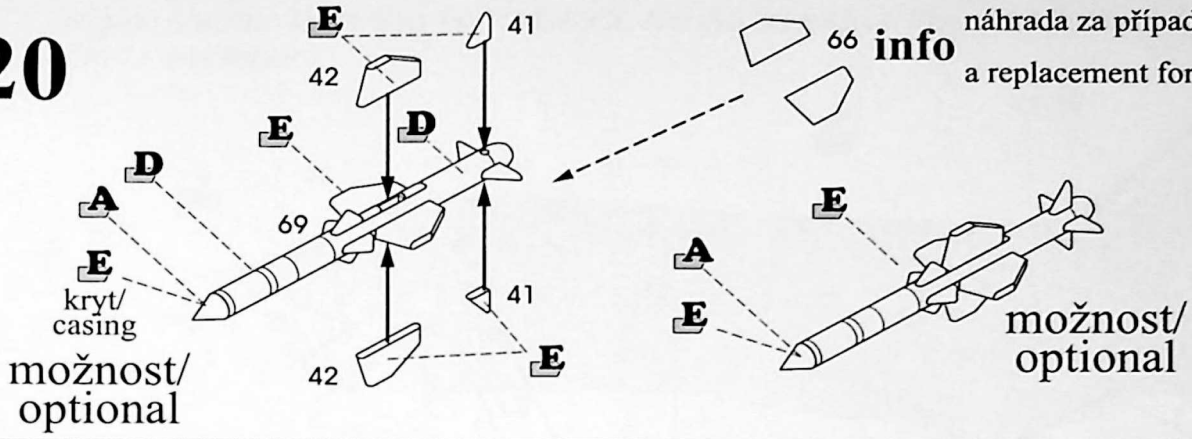

21

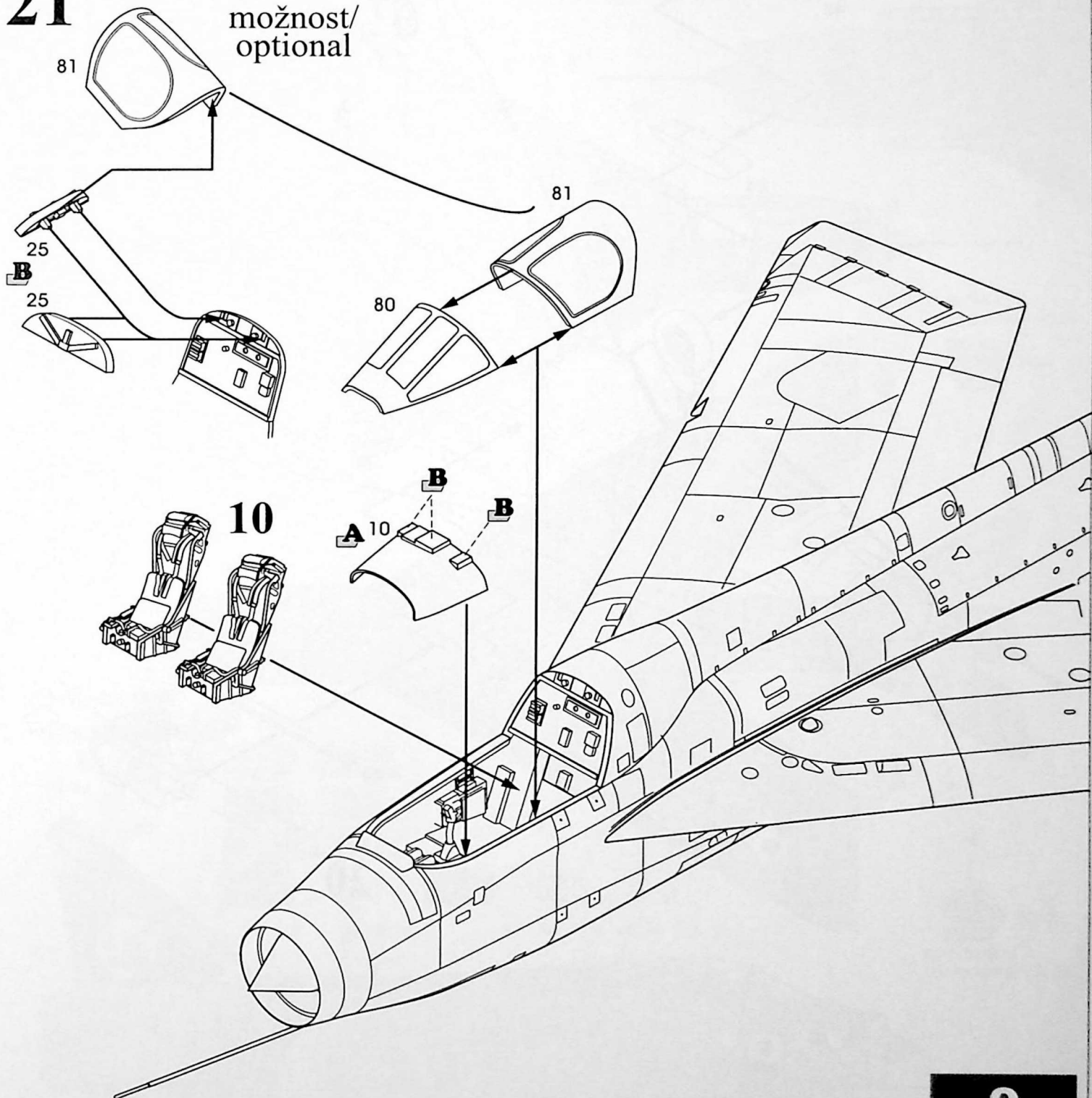

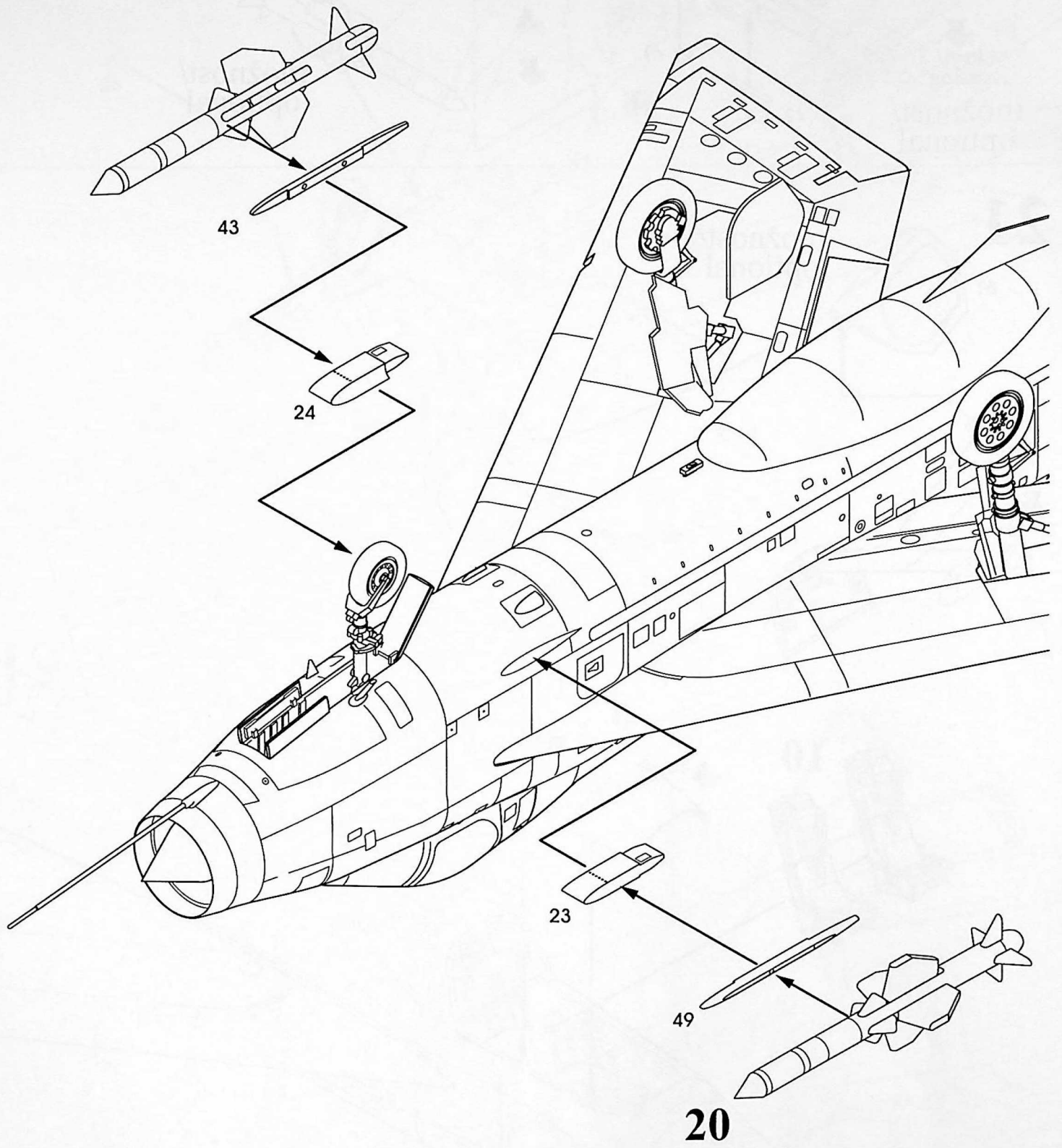

A

English Electric Lightning T.4, XM989/X, No. 56 Squadron Royal Air Force, 1963 - Wattisham

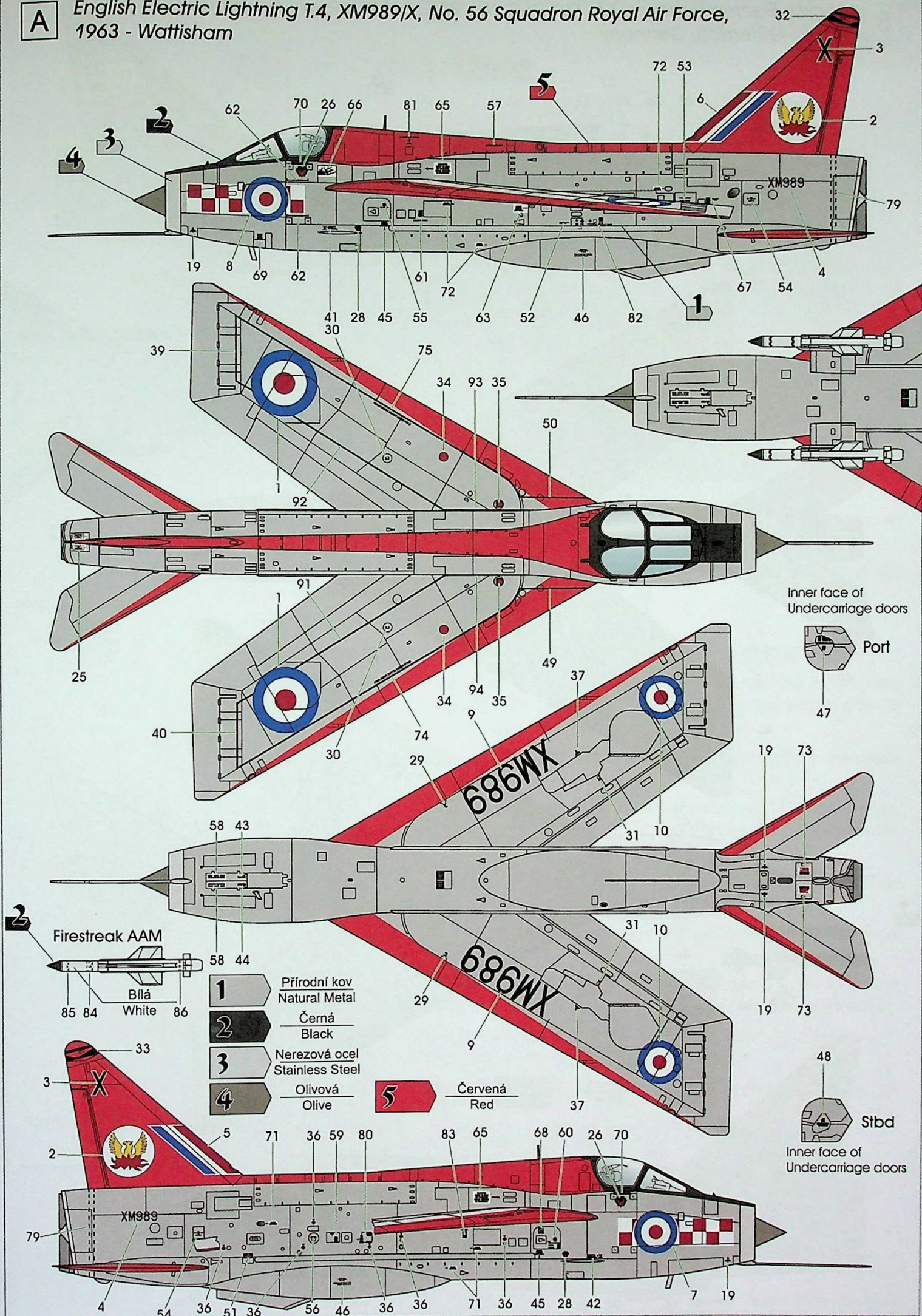

32
3

72 53

62 70 26 66 81 65 57

4 3 2

79
XM989

19 8 69 62 61 72 63 52 46 82 67 54 4

41 28 45 55 63 52 46 82

39 75 34 93 35

50

25 92 91 1 94 35 49 37

40 30 74 29 34 9 35 31 10

Inner face of Undercarriage doors

Port

47

19 73



Firestreak AAM

85 84 White 86

1 Přírodní kov
Natural Metal

2 Černá
Black

3 Nerezová ocel
Stainless Steel

4 Olivová
Olive

5 Červená
Red

19 73

48

Inner face of Undercarriage doors

Starboard

Inner face of Undercarriage doors

33 3 2 79 XM989 4 54 36 51 36 56 46 36 36 71 36 45 28 42 7 19

58 43 58 44 29 9 37 60 26 70 83 65 68 60 26 70



1



2

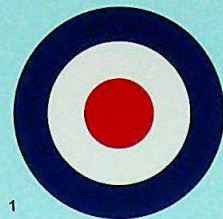

1

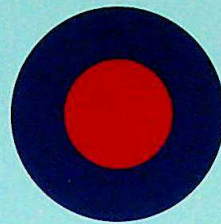

11



12



11

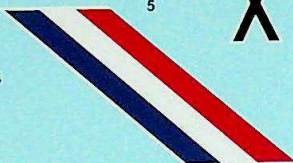
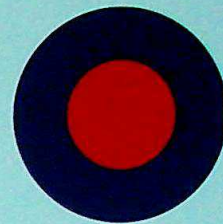

5

X X

3

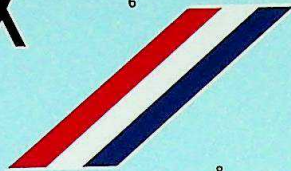

6



10



13



XM989₄

XM989

XM995

XM995



14



15

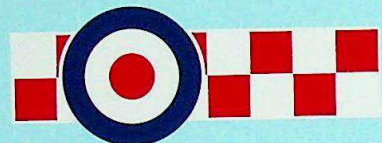

7



T T

17

XM995

18

XM995

XM989₉ XM989



26



27



28



29



30



31



32



33



39



40



34



35



36



37



38



41



42



43



44



45



46

19 20 21 22 23 24 25

51 52 53 54 55 56 57 58

59 60 61 62 63 64 65 66

67 68 69 70 71 72 73

78 79 80 81 82

83 84 85 86 87

88 89 90

91 92 93 94

X



41



42



43



44



45



74



75



76



77



78



79



41



42



43



44



45



74



75



76



77



78



79



41



42



43



44



45



74



75



76



77



78



79



41



42



43



44



45



74



75



76



77



78



79



41



42



43



44



45



74



75



76



77



78



79



41



42



43



44



45



74



75



76



77



78



79



41



42



43



44



45



74



75



76



77



78



79



41



42



43



44



45



74



75



76



77



78



79



SW 48008 EE(BAC) Lightning T.4

PRINTED BY TECHMOD