

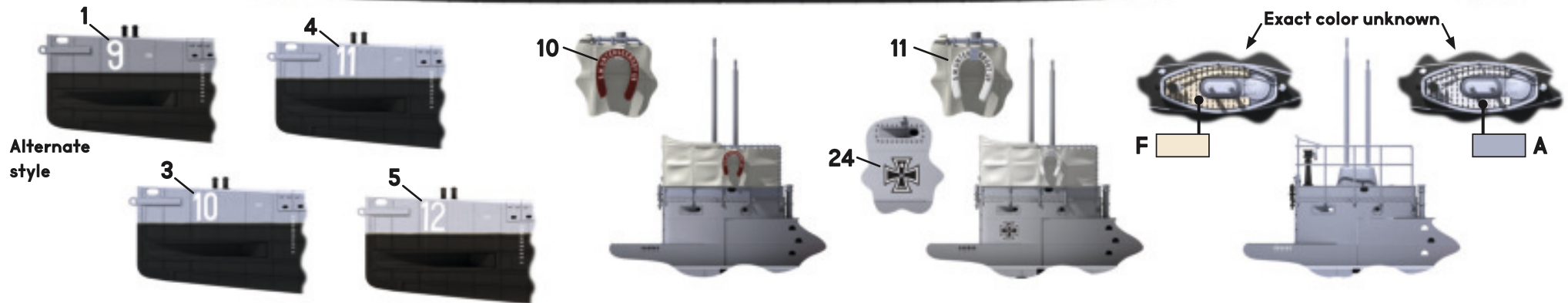

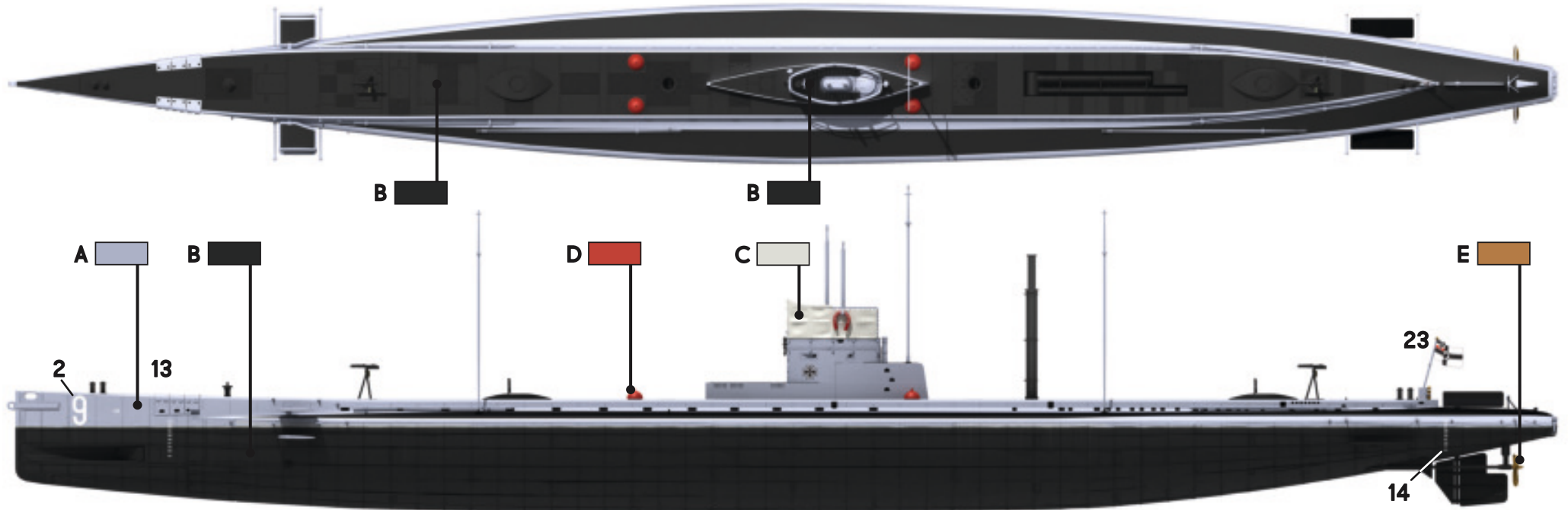



S.M. Unterseeboot U9

U9 Class: U9/U10/U11/U12

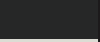

	COLOR	RAL / FS	Tamiya	Mr Hobby H-Series	AMMO of MIG	Vallejo	Humbrol	Mission Models
	A Light Grey / Hellgrau	7001	XF-19	H51	911	71050	127	MMP-042
	B Hull Grey / Schiffsbodenfarbe	7016	XF-77	H301	250	70995	32	MMP-045
	C Canvas	9001 / 7008	XF-49	H336	017	70879	103	MMP-044
	D Matte Red / Deckfarbe Rot	3011	XF-7	H13	049	70947	60	MMP-003
	E Bronze	-	X-33	MC219	190	70998	55	MMM-009
	F Deck Tan	-	XF55	H10	088	71122	71	MMP-019

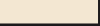
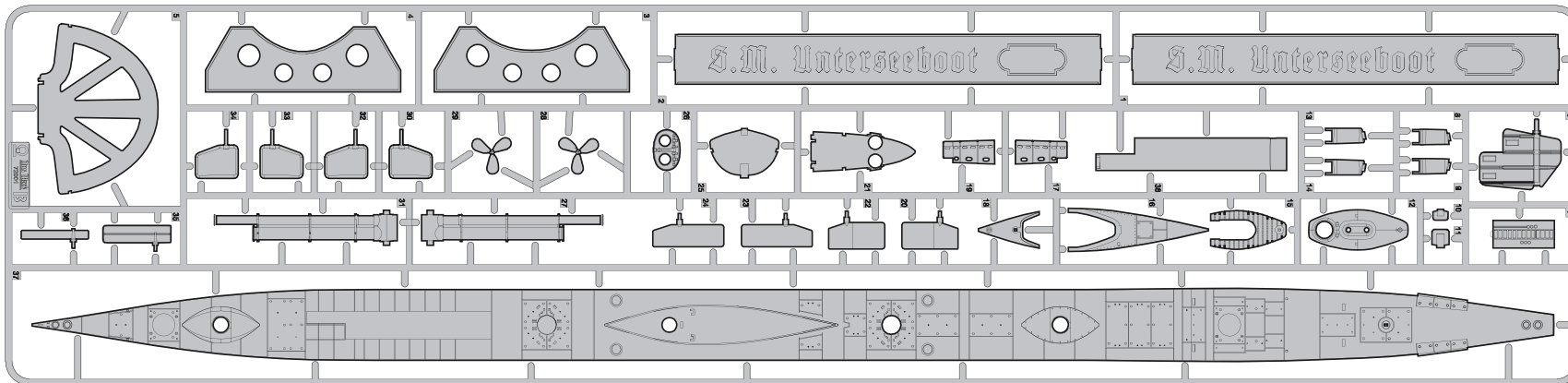
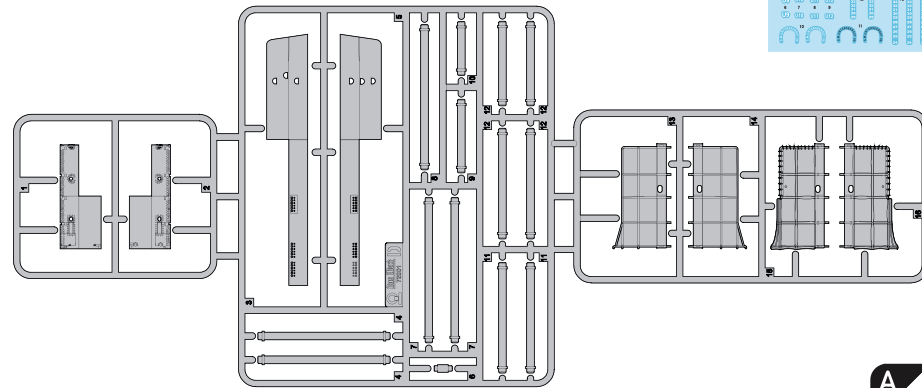
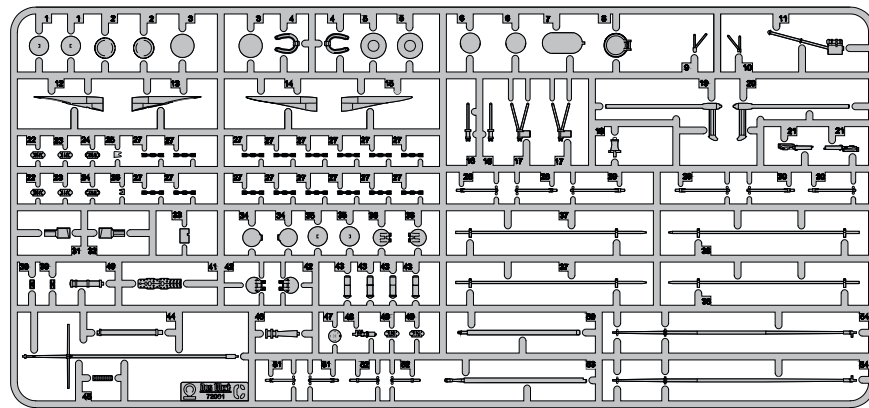
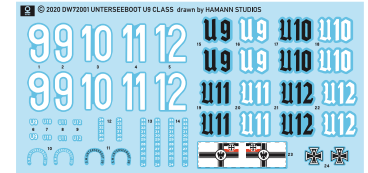
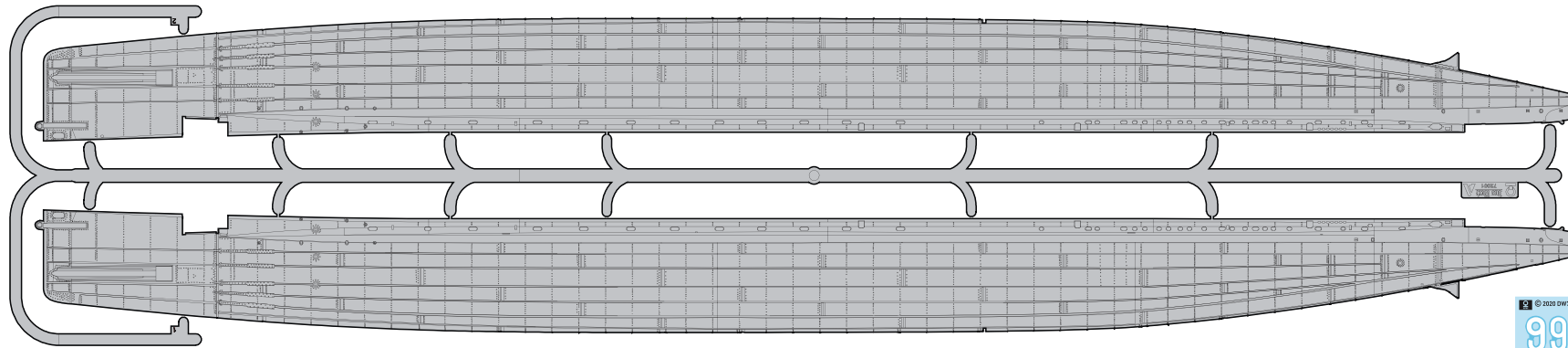

USE
NIPPERS

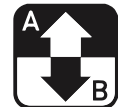

OPTION



PAINT



ACHTUNG!



DECALS



NO GLUE



REPEAT

S.M. Unterseeboot U9

S.M. Unterseeboot U9

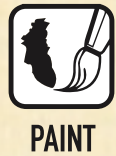
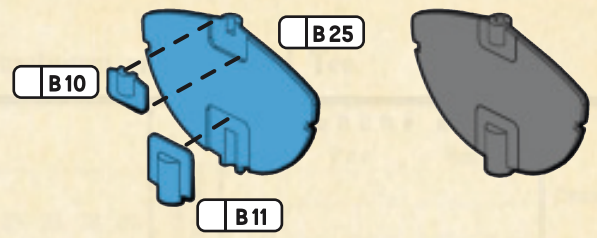
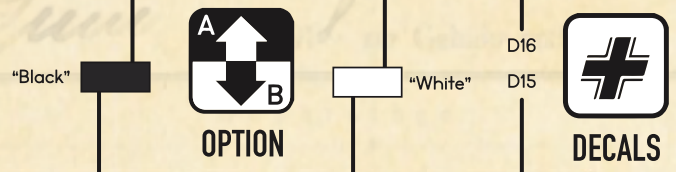
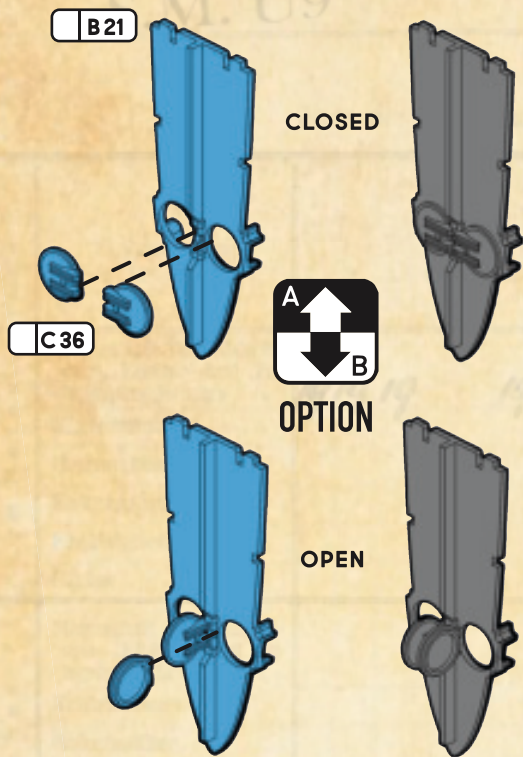

Glue the spreader bars to only one of the hull halves

ACHTUNG!

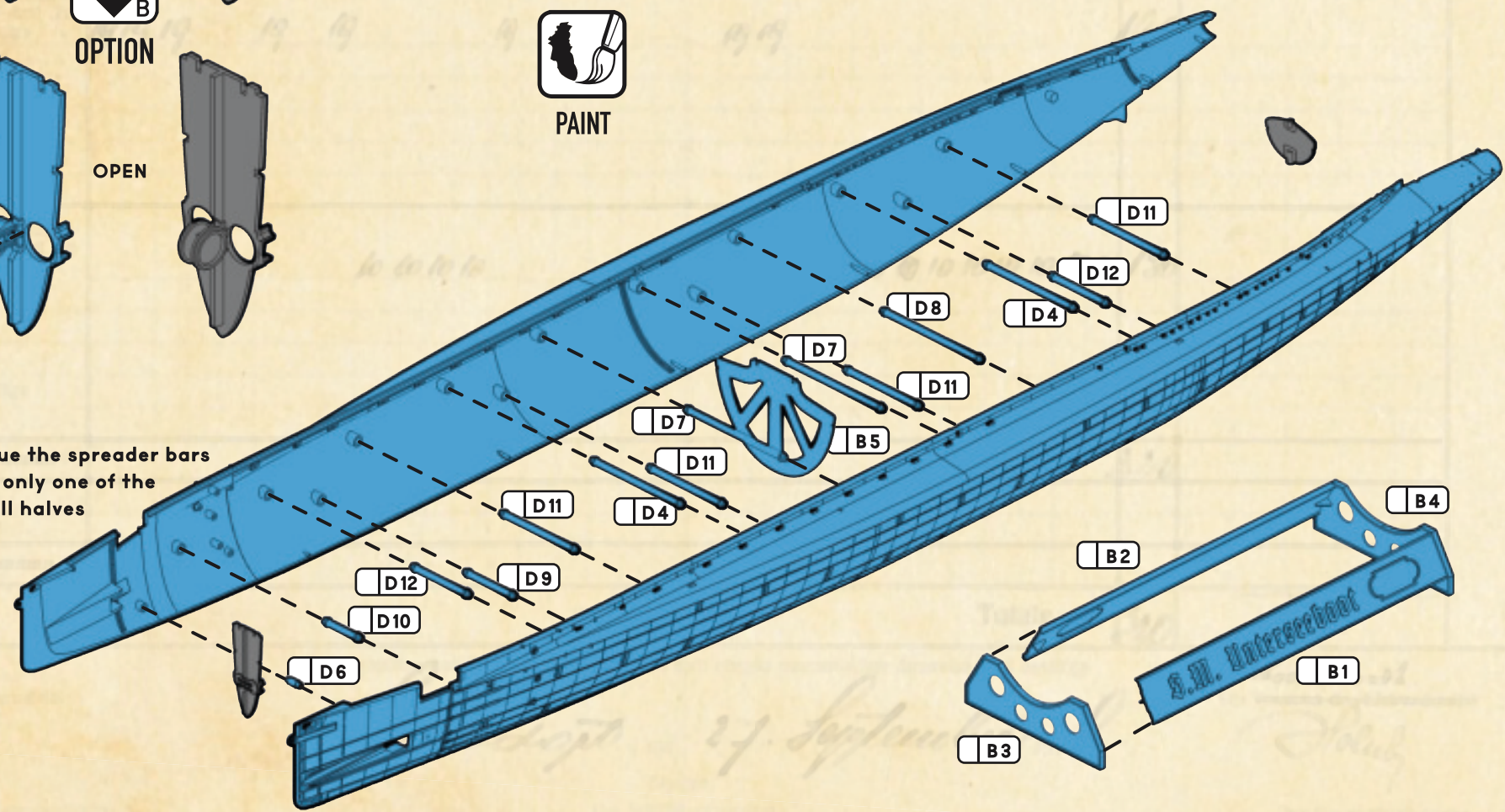

5

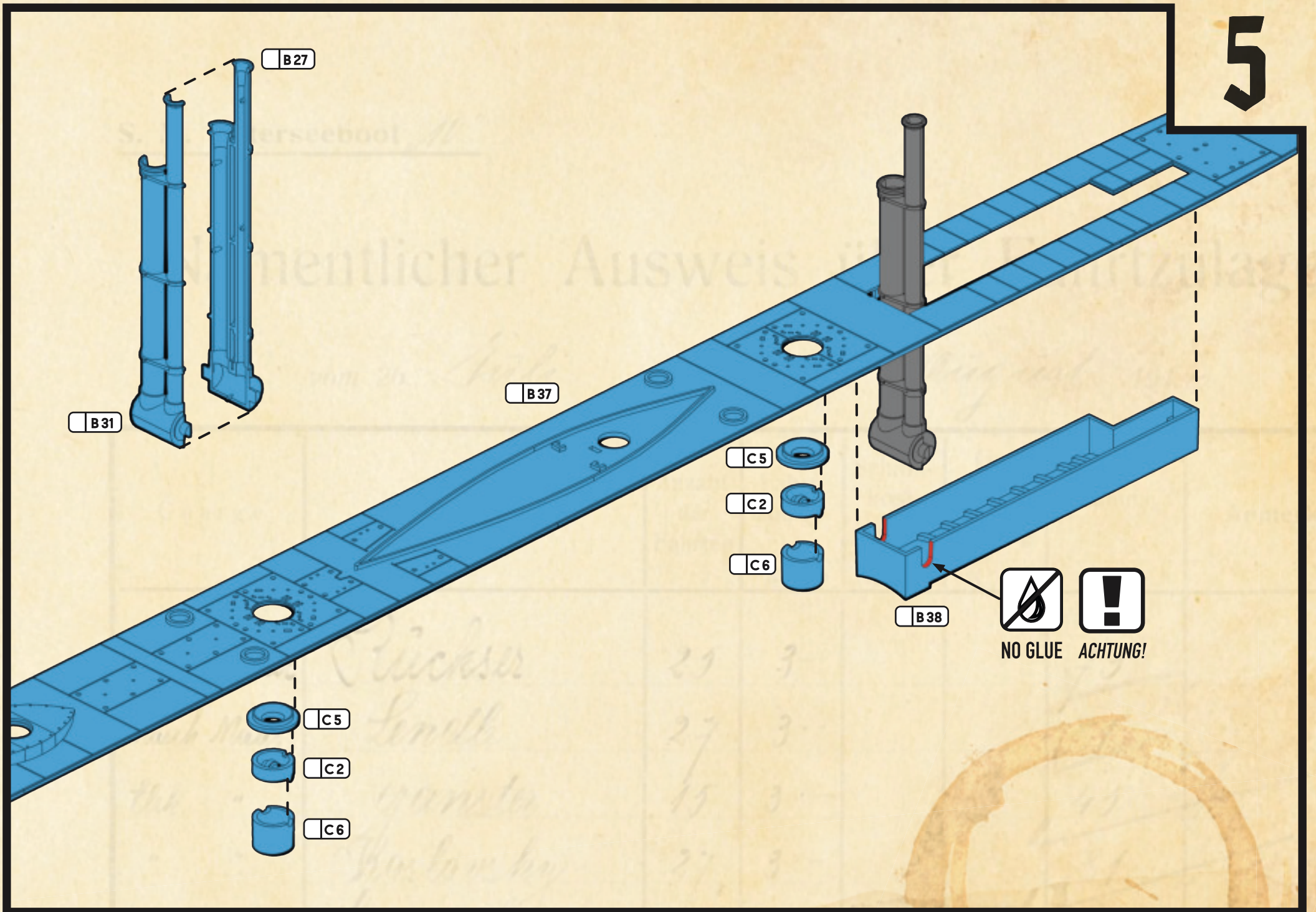

B27

B31

B37

C5

C2

C6

B38

C5

C2

C6



NO GLUE



ACHTUNG!

S.M. U9

Ausweis



ACHTUNG!

Insert the deck assembly into the hull assembly starting at the rear and slowly work it into place moving from rear to front.

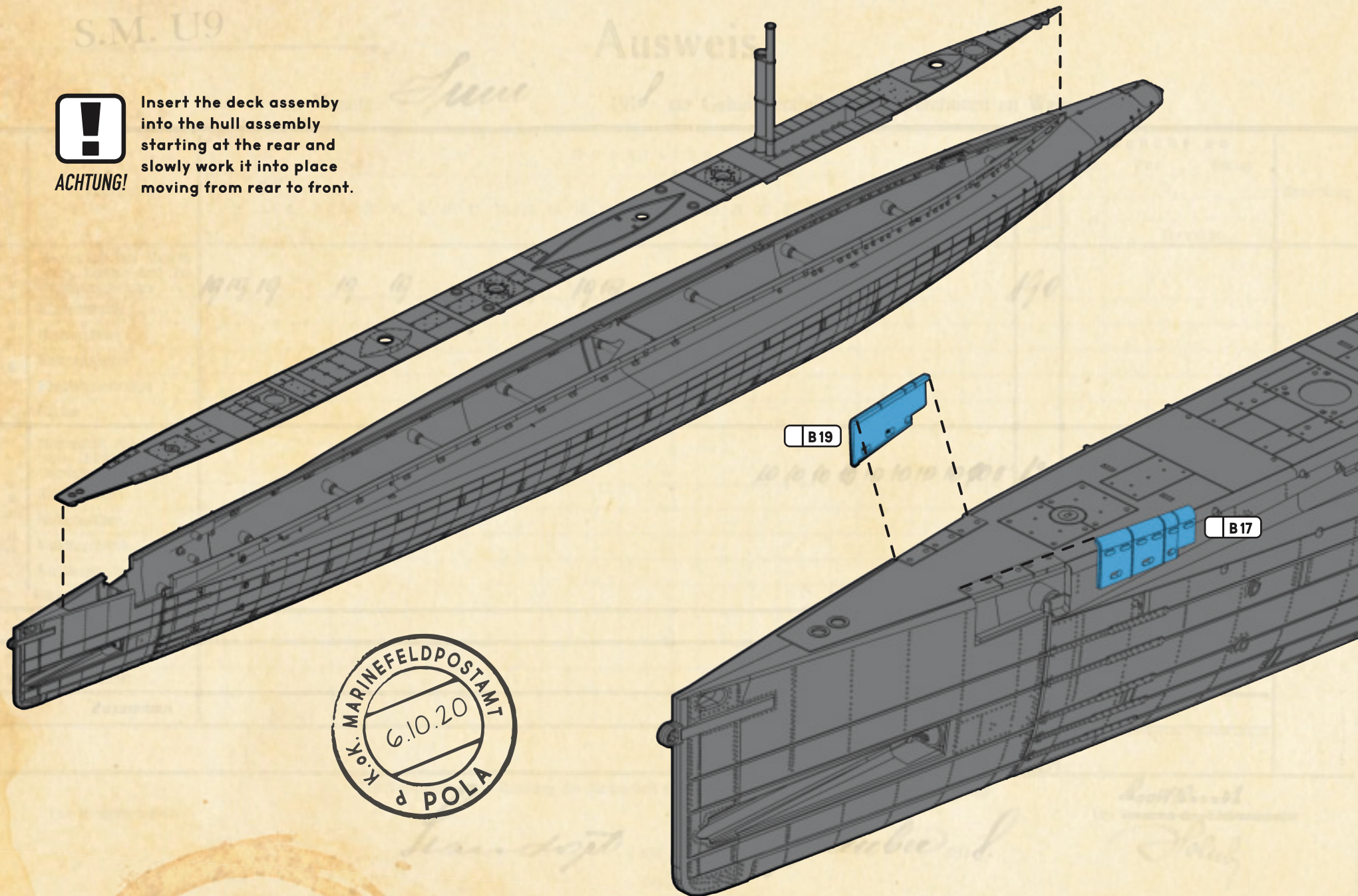

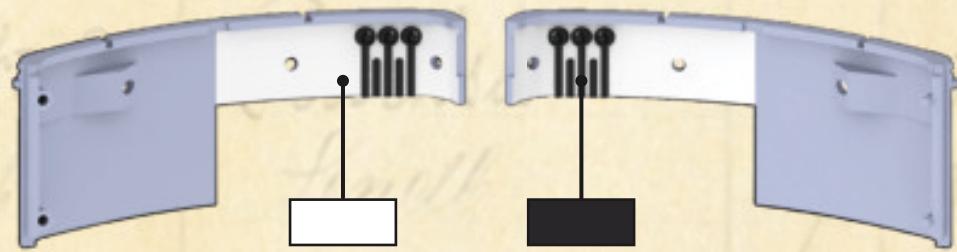
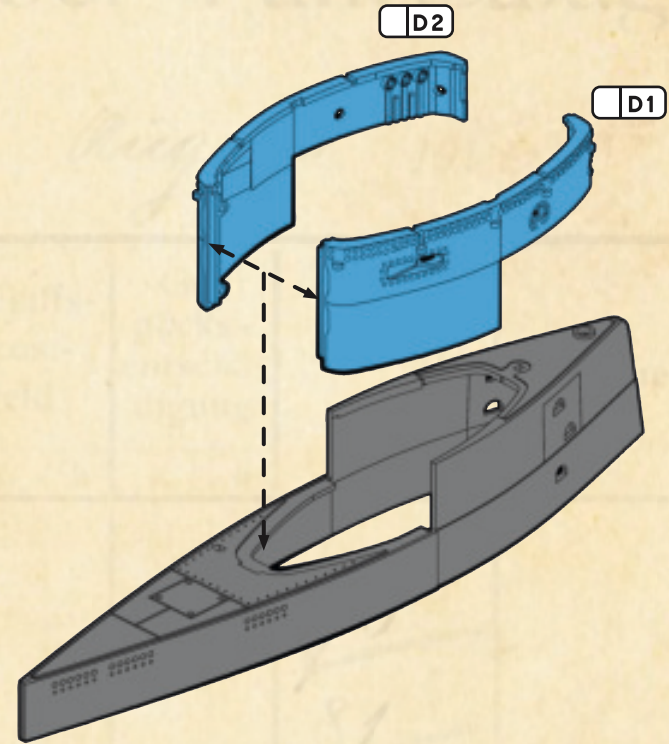
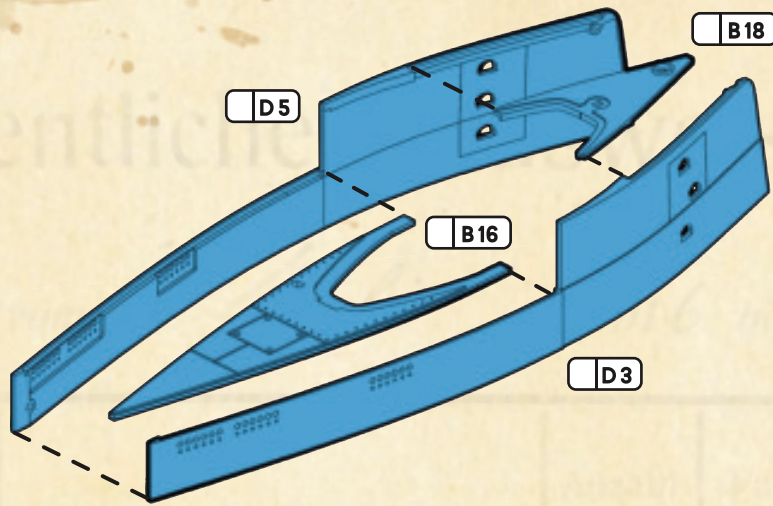

"White"

"Black"



PAINT

S.M. U9

Ausweis

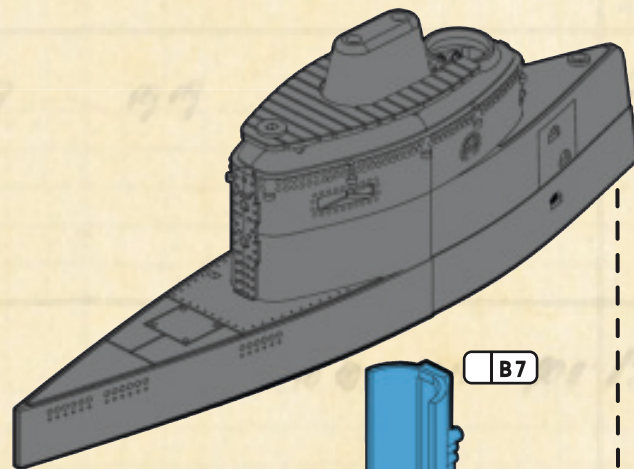
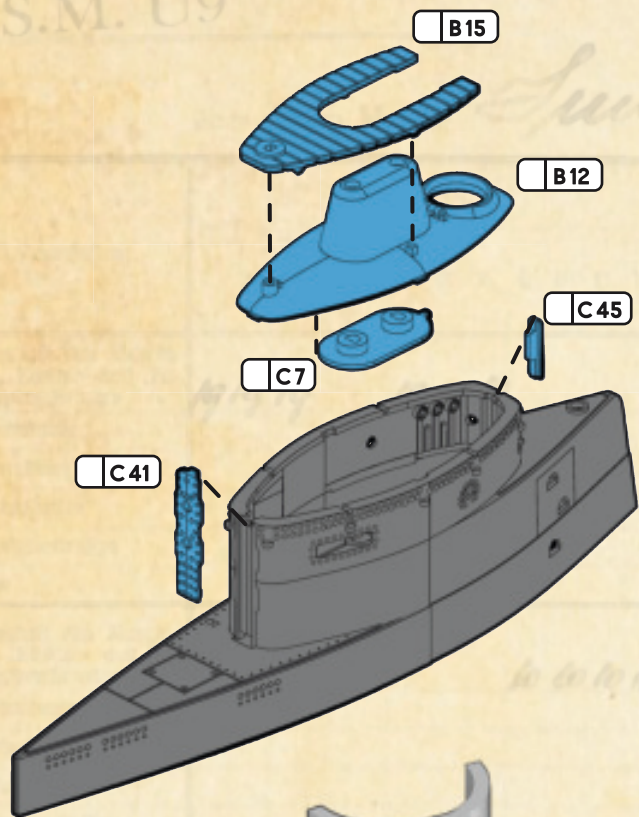

PAINT

White

Black



B7

B7

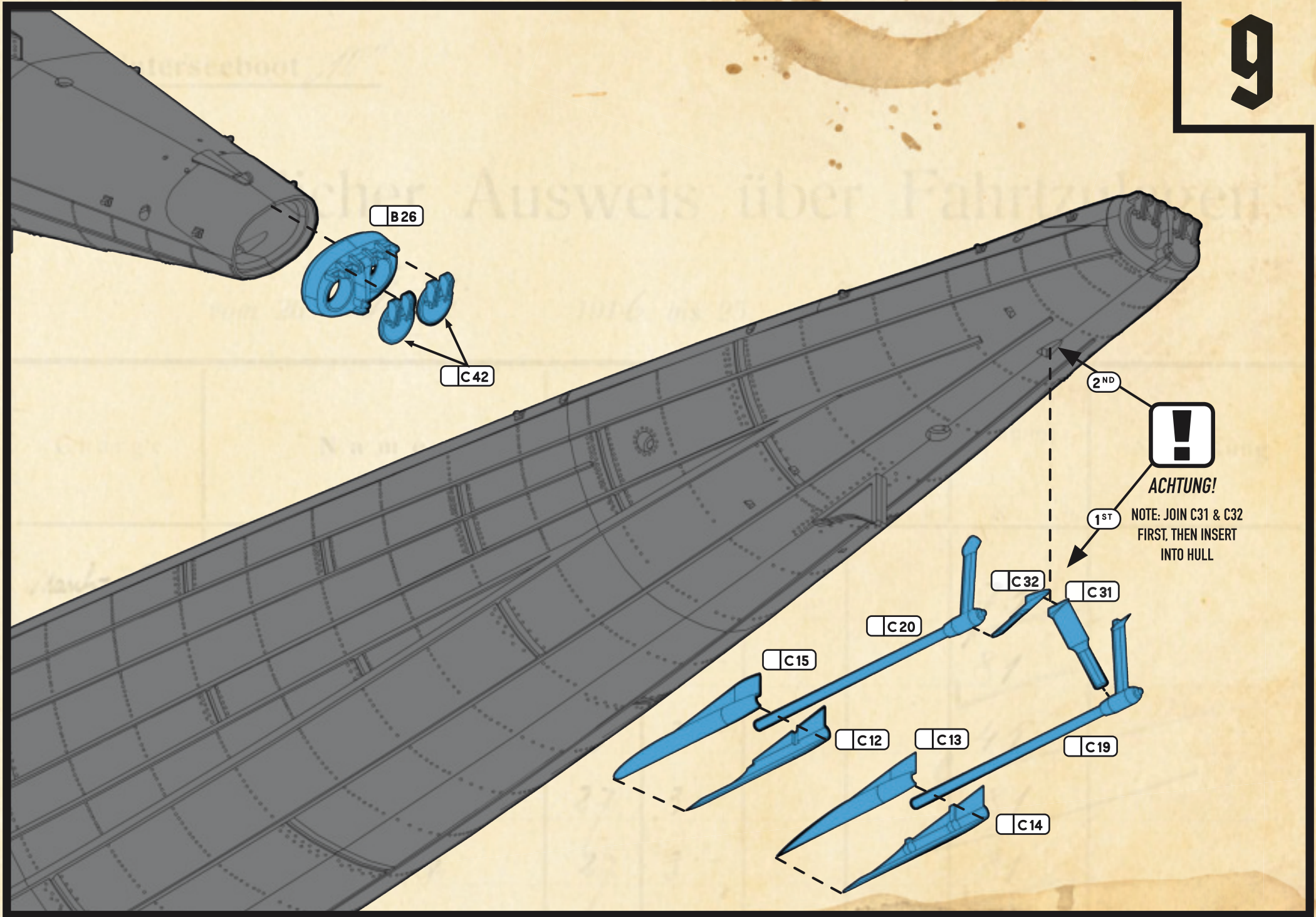

S.M. U9

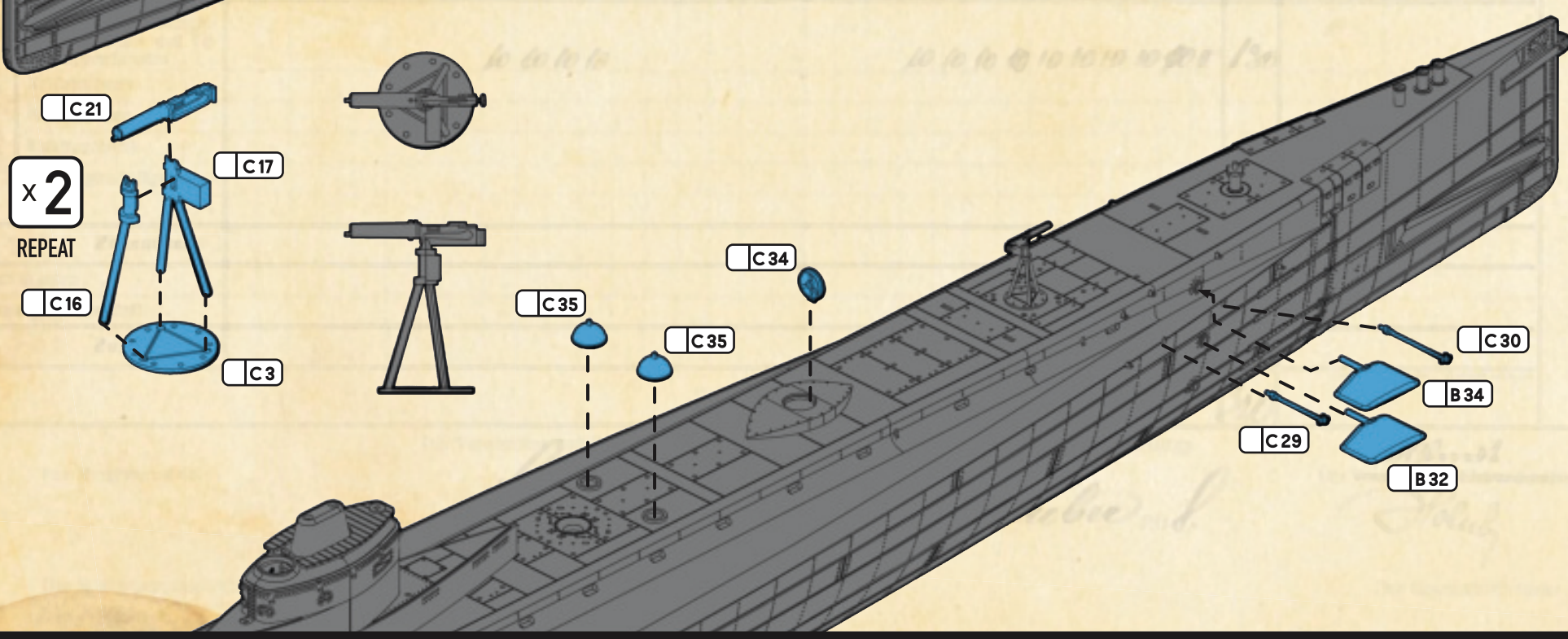
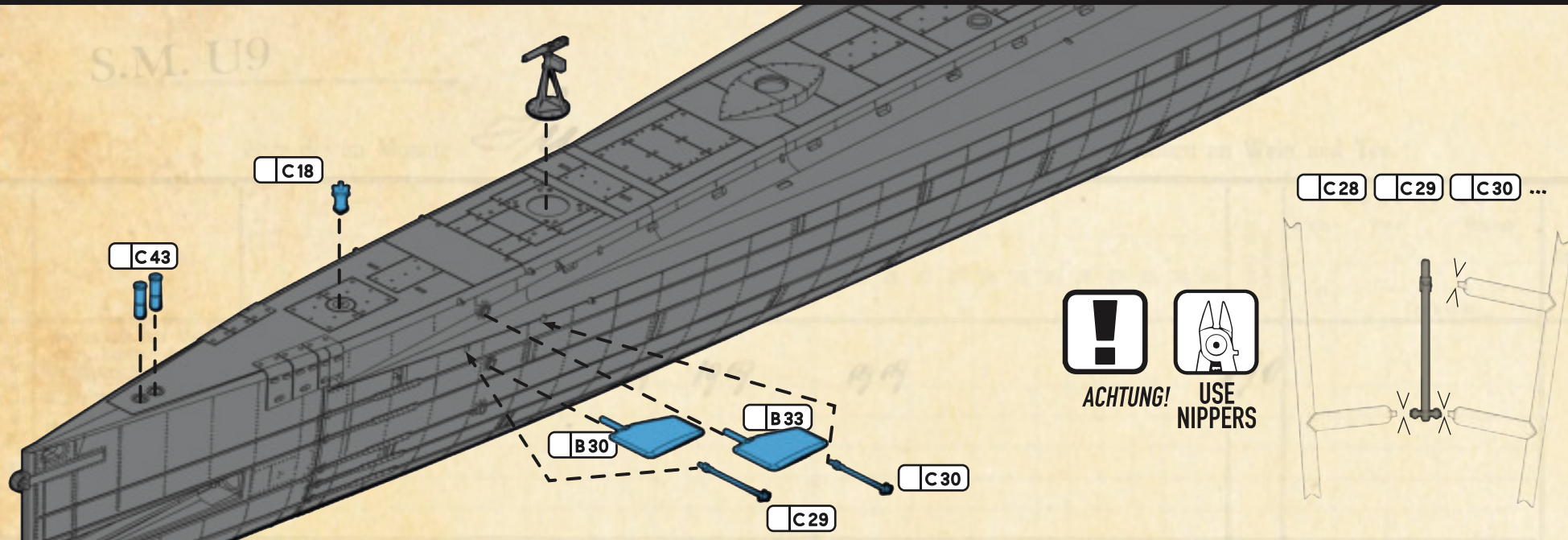

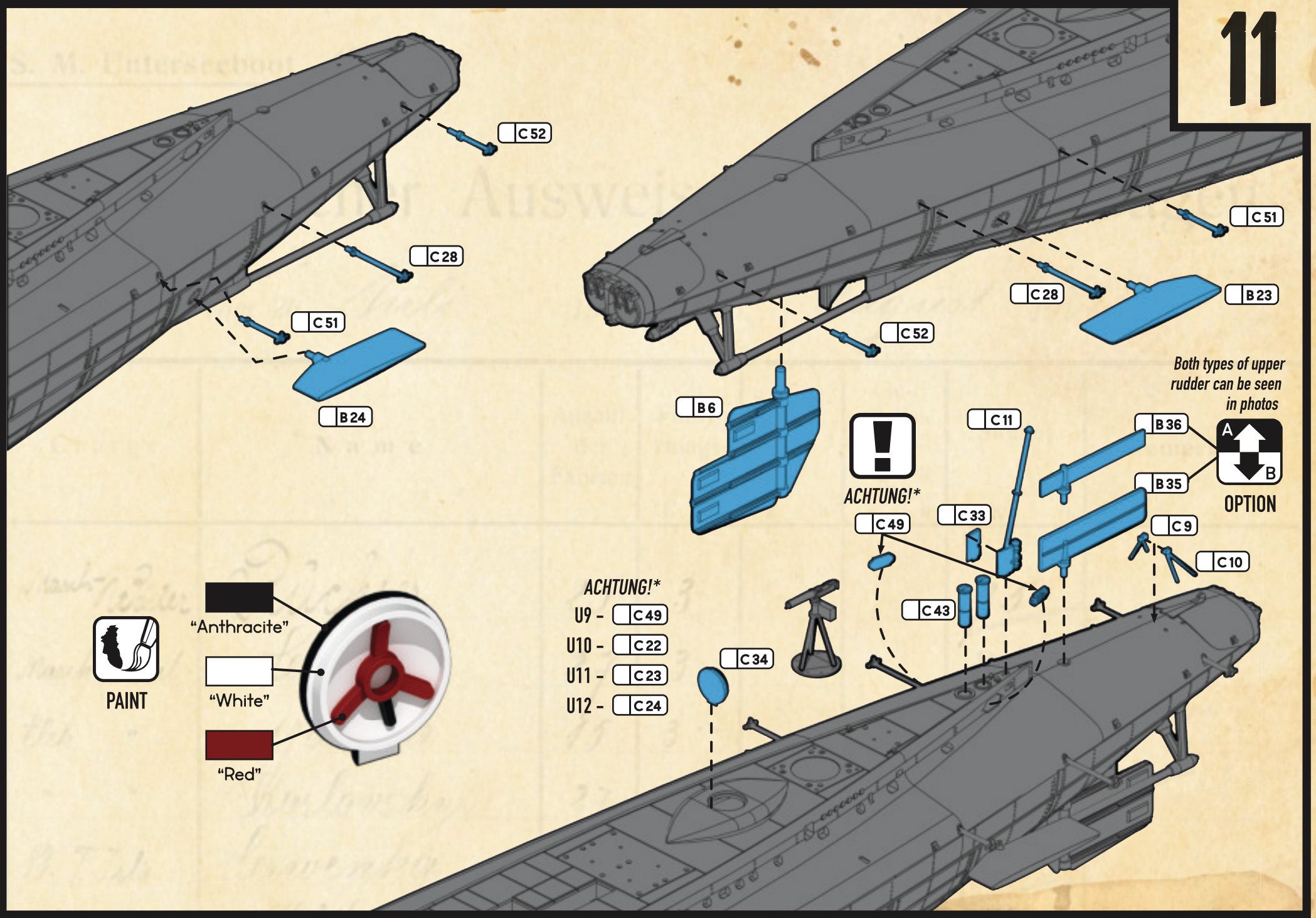

Both types of upper rudder can be seen in photos



ACHTUNG!*

- ACHTUNG!***
- U9 - C49
 - U10 - C22
 - U11 - C23
 - U12 - C24



PAINT

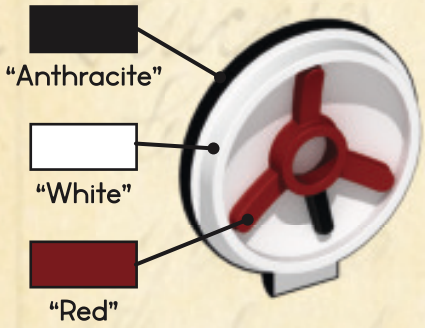



OPTION

Turnbuckles (PART C27) have been supplied in the event that you would like to add them according to the diagram below.



ACHTUNG!*
Drill hole with .5mm drill bit while parts are still attached to sprue!



C27

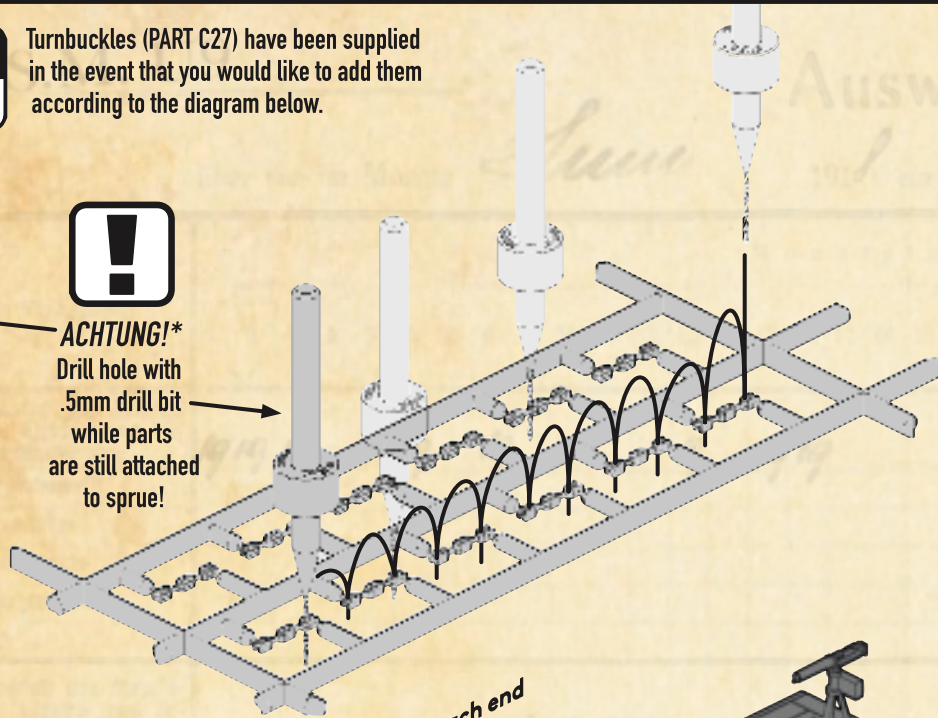

OPTION

B14



B9

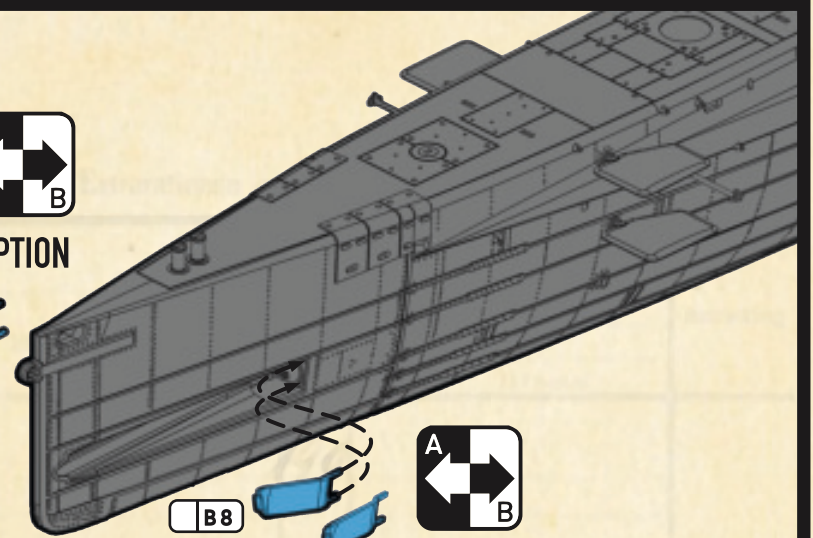

B8



B13

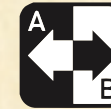

OPTION

x16

REPEAT

30mm minimum each end

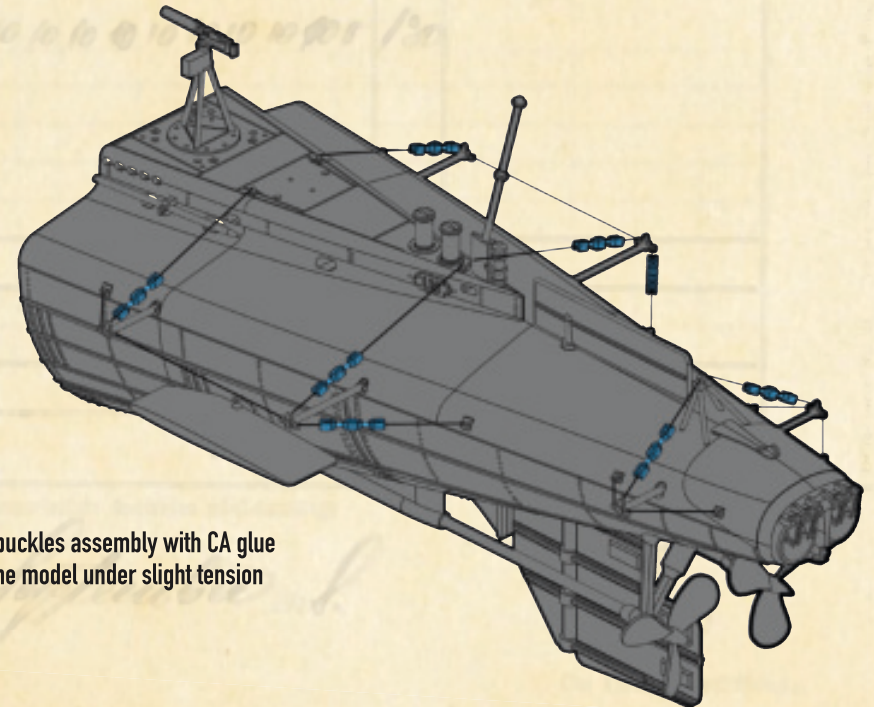
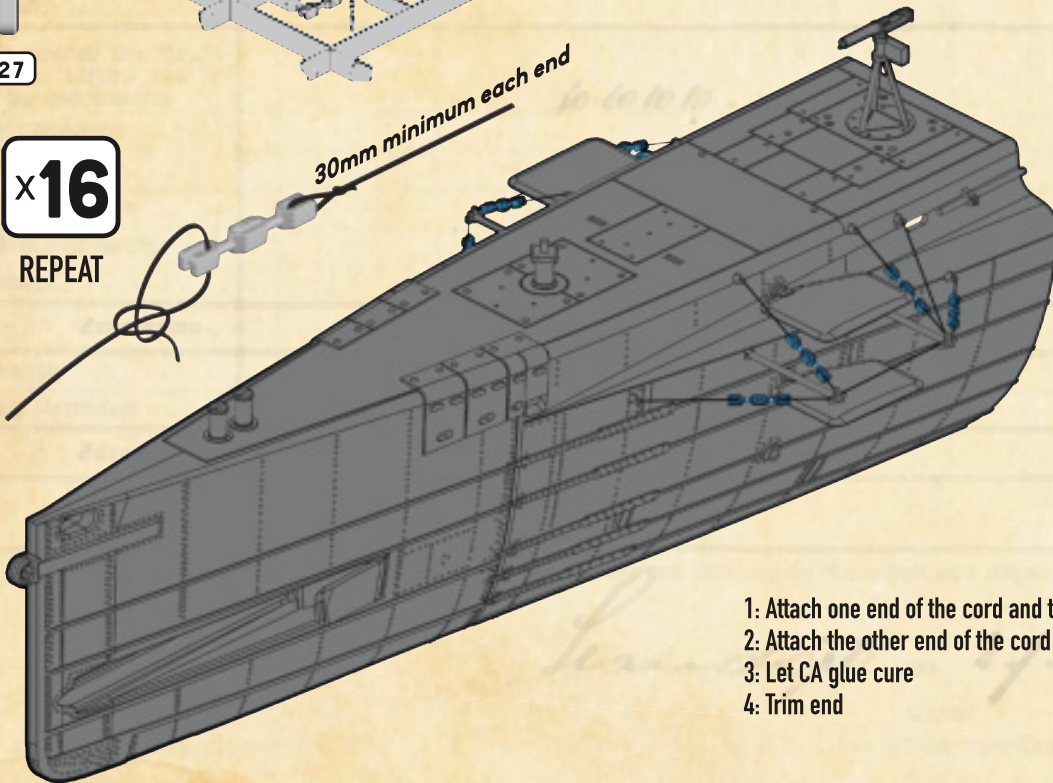

- 1: Attach one end of the cord and turnbuckles assembly with CA glue
- 2: Attach the other end of the cord to the model under slight tension
- 3: Let CA glue cure
- 4: Trim end

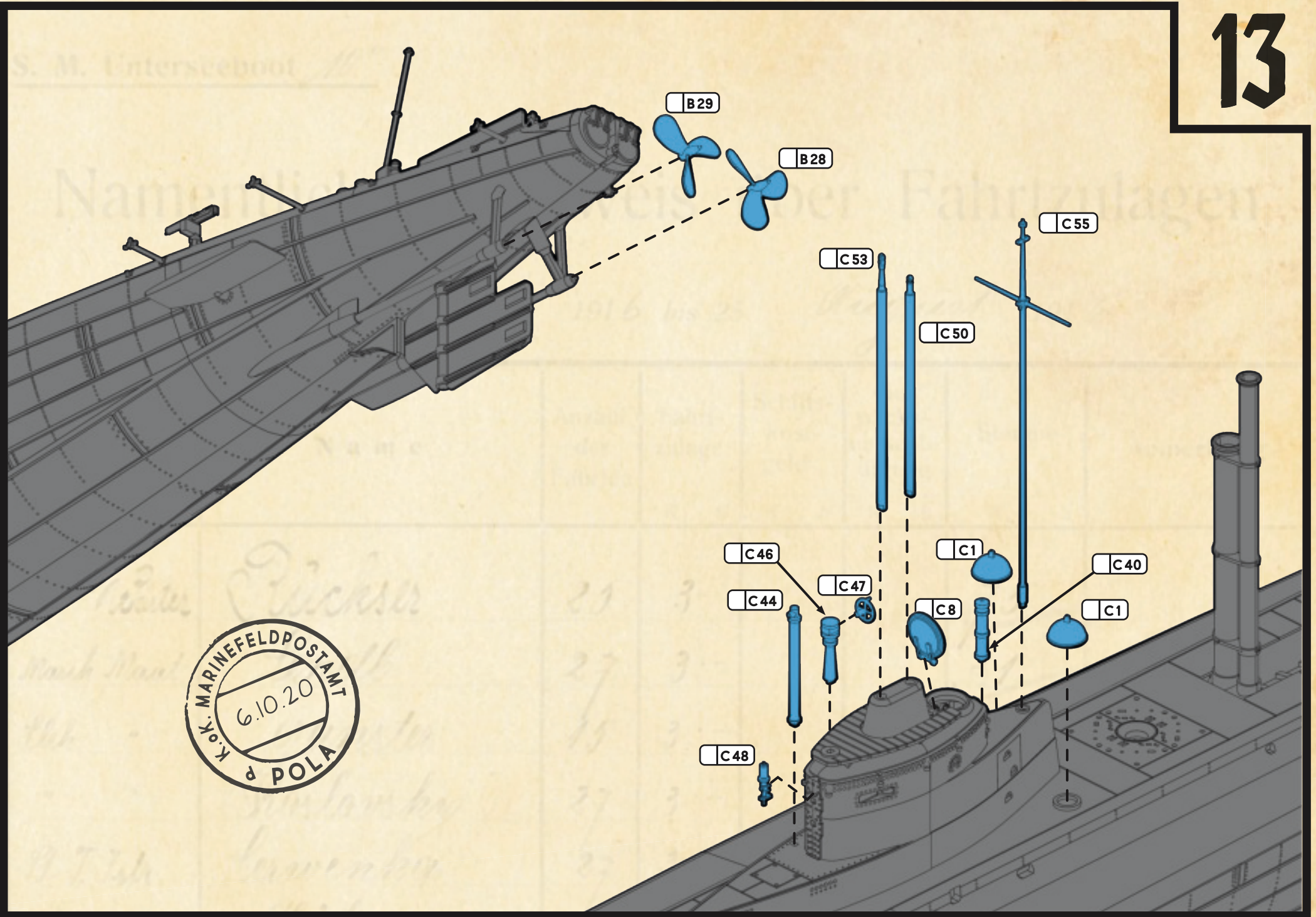

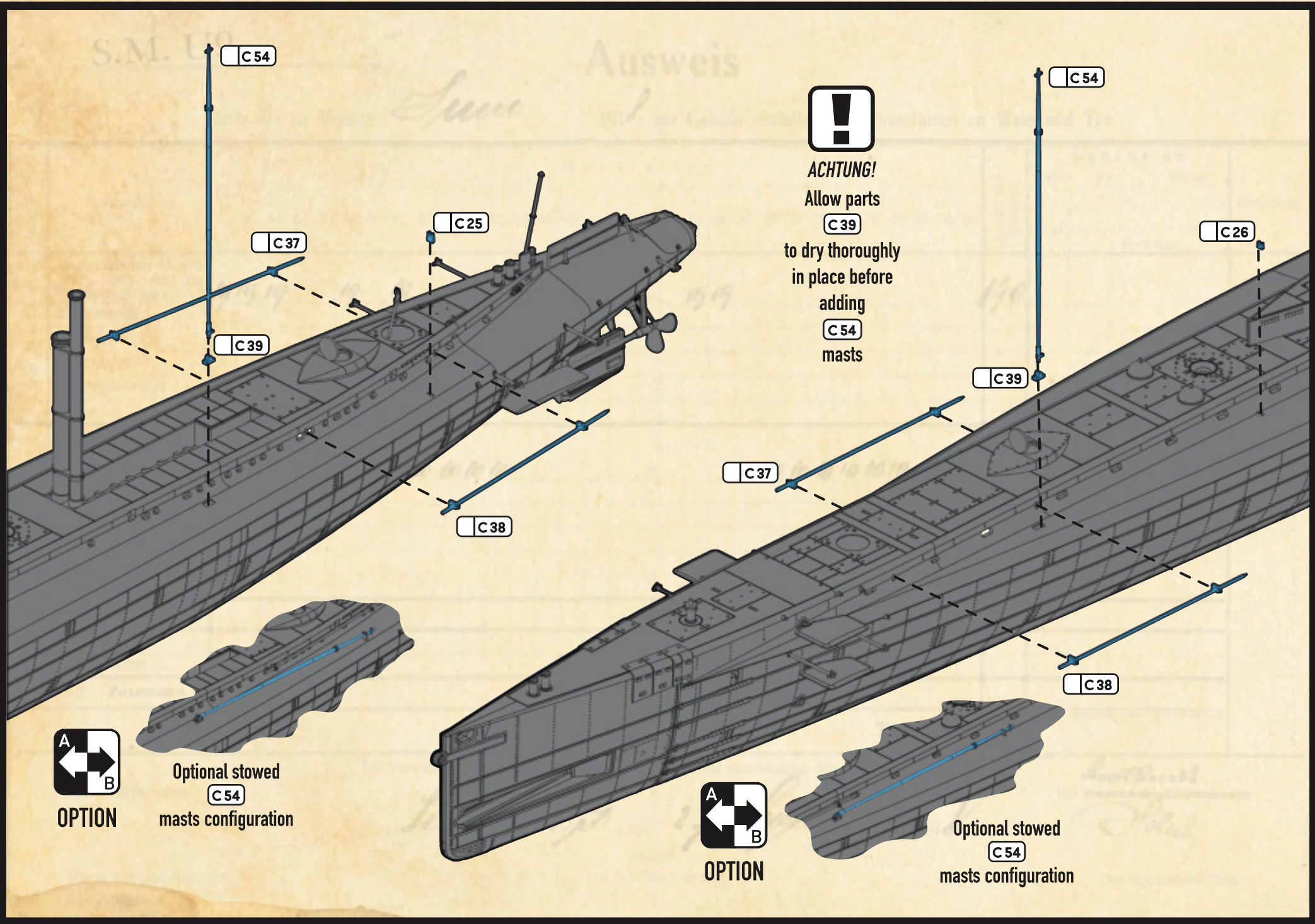

S.M. U 9

Ausweis

Sum



ACHTUNG!
Allow parts
C39
to dry thoroughly
in place before
adding
C54
masts

C54

C37

C25

C39

C38

C54

C26

C39

C37

C38



OPTION

Optional stowed
C54
masts configuration

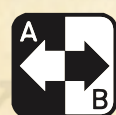

OPTION

Optional stowed
C54
masts configuration

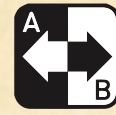
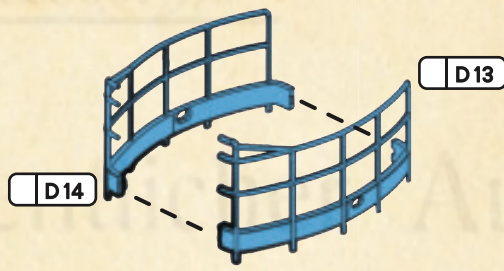

OPTION



NO GLUE

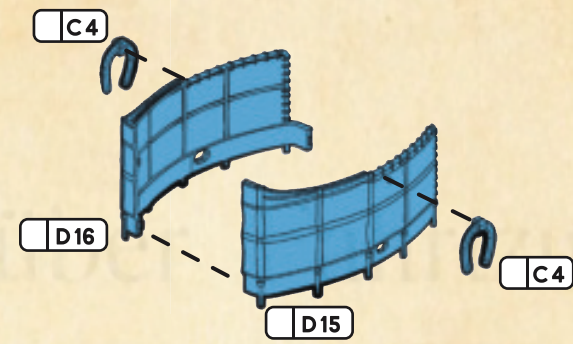

INTERCHANGABLE AT ANY TIME IF NO GLUE IS USED

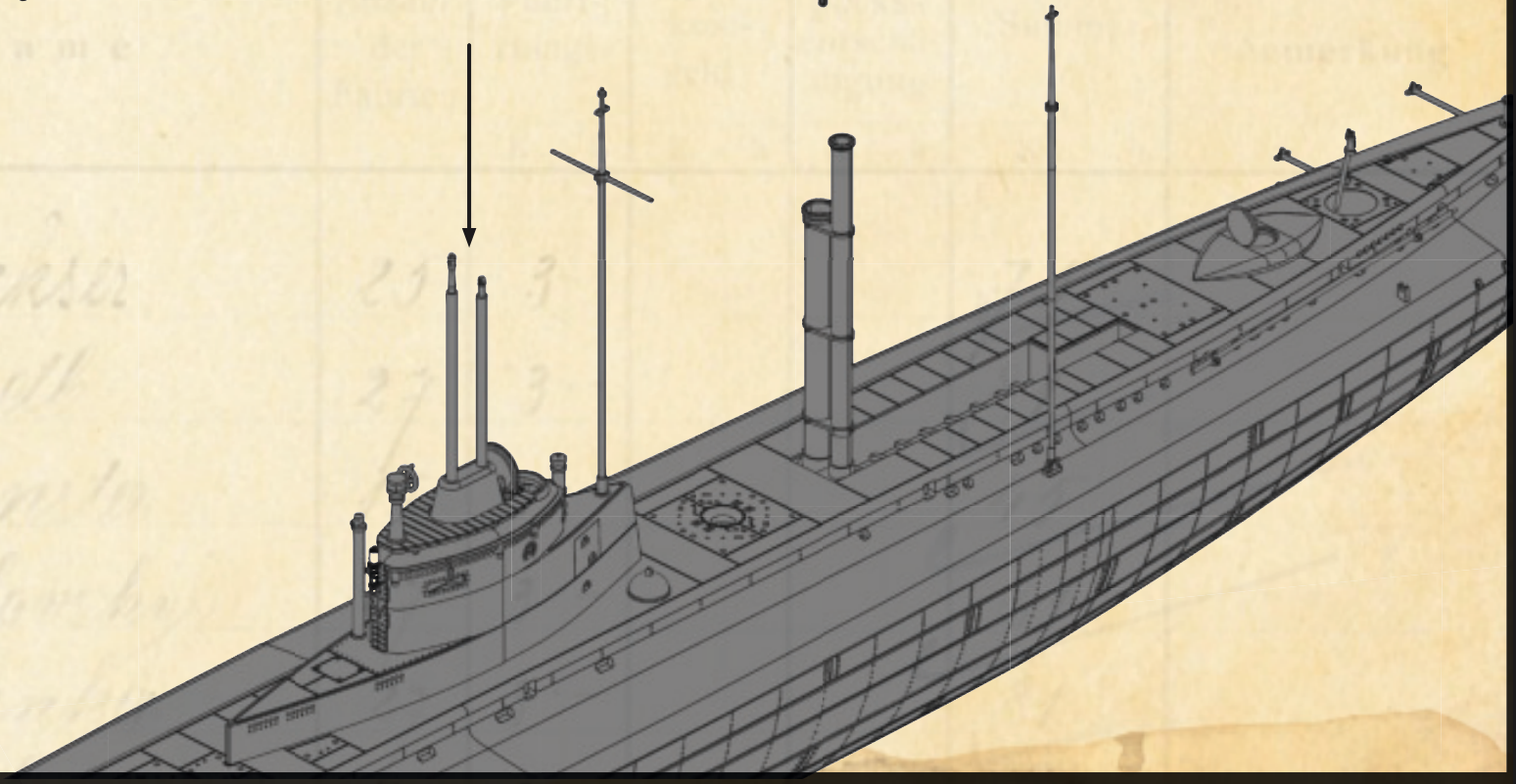



Harald Bauske ~ CEO

As the owner and managing director of Modellbau König, Germany, Harald assembled a team of creative professionals and provide the budgets to pursue on of his dreams: releasing his own favourite subjects as plastic models kit under his own brand. Back in 1999, when he made the first steps with his company, he did not imagine that this dream would ever become a reality.

Harald is very proud and happy that the models from Das Werk not only appeal to him but also that so many other model makers have fun with the kits



Pete Hamann ~ 3D designer, CAD modeler, Graphic Design

Born and raised in California, Pete worked on his design chops as an aerospace designer in Seattle, Washington, before packing up and relocating to Spain. He developed a deep interest in flying machines while growing up next to military air bases in Southern California. After spending a few years as a machinist, making other people's designs a reality, he obtained a bachelor of arts degree in industrial design from The Academy of Art in San Francisco, California.

Pete can be reached at Peterjhamann@gmail.com



Felipe Rodna ~ Box art

Born in 1976, Felipe lives with his wife and two children in Salamanca, Spain, where he works as an architect and digital artist. He combines his experience in 3D digital art with his passion for modelling in his illustrations, where he always strives to achieve a balance between technical detail and craft. His illustration credits include books for Osprey publishing, Panzerwrecks, Peko publishing, Canfora Publishing, Tankograd, and the Spanish magazine Despeta Ferro.

Felipe can be reached at feliperodna@hotmail.com

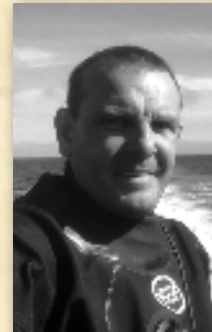

Neil Richmond ~ Mixed Gas Closed Circuit Rebreather Diver and Instructor, Underwater videographer and Diving Expedition Leader. Neil had been diving for almost 30 years, and been instructing at all levels for the last 20 years, sharing his skills to allow others to access the more adventurous and technically demanding dive sites that are his passion. Neil has spent much of his spare time locating and diving historic offshore wrecks from both his own RIB "EQUINOX" and local charter boats. His use of closed circuit rebreather technology allows much longer and deeper exploratory and survey dives to be safely conducted. Neil can be reached at neil_m_richmond@icloud.com



James Hartley ~ Commercial Skipper, Wreck and Cave Diver, Vice Chairman of Berwickshire Marine Reserve. Born in Yorkshire, UK, James had a background in construction survey and management. 15 years ago he discovered Scuba diving. Once he began wreck diving and discovered the amount of history buried under the waves around the UK he was hooked. He's dived 10 Submarines around the UK, five U-boats and was involved in a ministry of defence survey of UC-39 off his native Yorkshire coast.

Das Werk and Hamann Studios would also like to thank the following people for their contribution to this project:

Bernhard Wenzel

Paul Webster ~ Underwater Photographer (paul@paul-webster.co.uk)

Carlos Elias Llop

A DAS WERK production 2020
Modellbaukönig GmbH & Co. KG
Nordenhamer Str. 177
27751 Delmenhorst
Deutschland