

KOVOZÁVODY

PROSTĚJOV

# Hawker Tempest Mk V

## Historie

Hawker Tempest (v angličtině bouře) byl velmi výkonným britským jednomotorovým stíhacím letounem druhé světové války. První sériový Tempest Mk.V (JN729) byl zalétán 21. června 1943. Již od počátku výroby byly Mk.V vybaveny kapkovitým krytem kabiny a čtyřadvacetiválcovým řadovým motorem Napier Sabre IIA o vzletovém výkonu 1603 kW. Prvních sto kusů Mk.V Series 1 bylo vyzbrojeno čtveřicí kanónů British Hispano Mk.II instalovaných v křídle, jejichž hlavně o 0,2 m přesahovaly náběžnou hranu. Další Tempesty Mk.V Series 2 obdržely kanóny Hispano Mk.V s kratší hlavní. Tempesty byly poprvé bojově nasazeny začátkem května 1944 nad Francií při útocích na dopravní systém a letiště. Letadla Tempest aspirovala díky své rychlosti i ostatním vlastnostem na titul nejlepší stíhačky Royal Air Force.

## History

The Hawker Tempest was a very powerful British single-engine fighter aircraft of World War II. The first serial Tempest Mk.V (JN729) was flown on June 21, 1943. From the beginning of production, the Mk.V were equipped with a teardrop-shaped cabin cover and a twenty-four-cylinder inline engine Napier Saber IIA with a takeoff power of 1603 kW. The first hundred pieces of the Mk.V Series 1 were armed with four British Hispano Mk.II cannons installed in the wing, whose barrel by 0.2 m exceeded the leading edge. Other Tempesty Mk.V Series 2 received Hispano Mk.V cannons with a shorter barrel. Tempests were first deployed in combat in early May 1944 over France during attacks on the transport system and airports. Thanks to its speed and other characteristics, Tempest aircraft aspired to the title of the best Royal Air Force fighter.



OPTIONAL  
VOLITELNĚ



DRILL HOLE  
VYVRTAT



SYMMETRICAL  
SYMETRICKY



REMOVE  
ODSTRANIT

Plastikové díly/  
Plastic parts

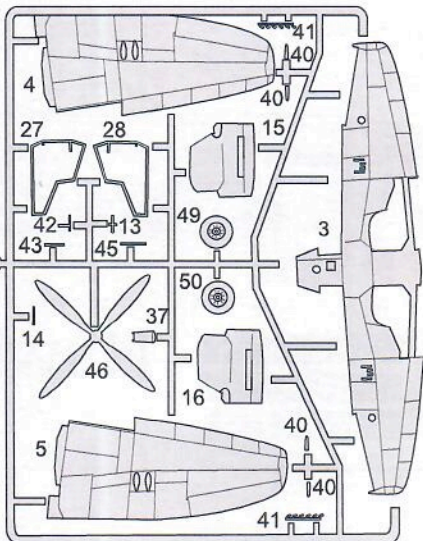
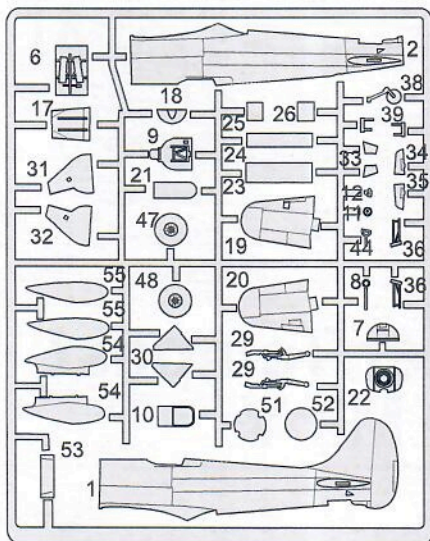

Průhledné díly/  
Clearer parts

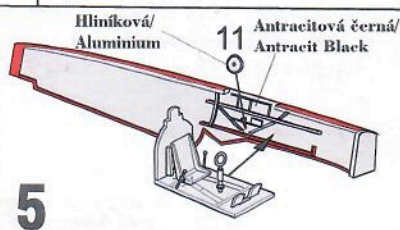
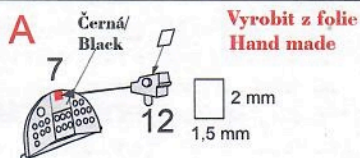
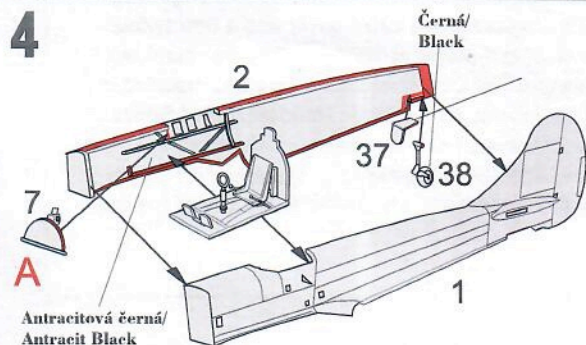
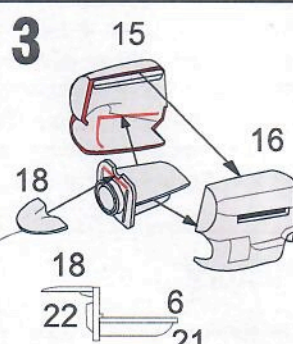
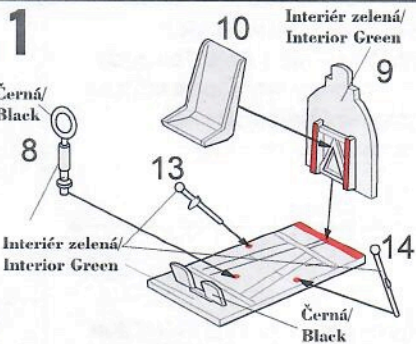

6

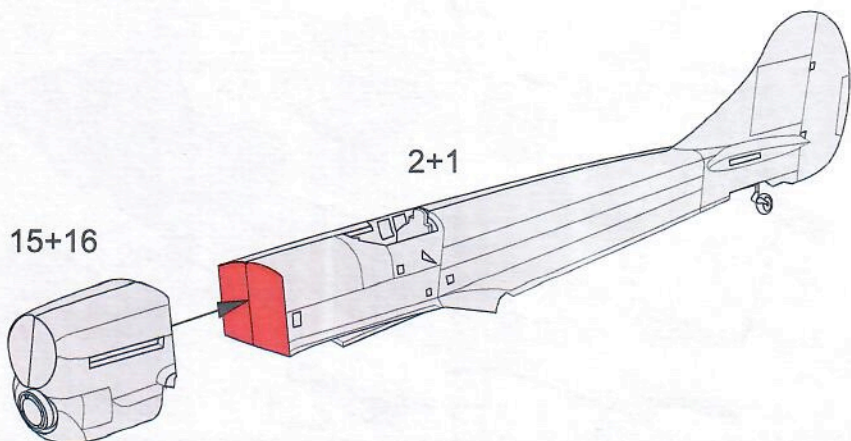

8

7

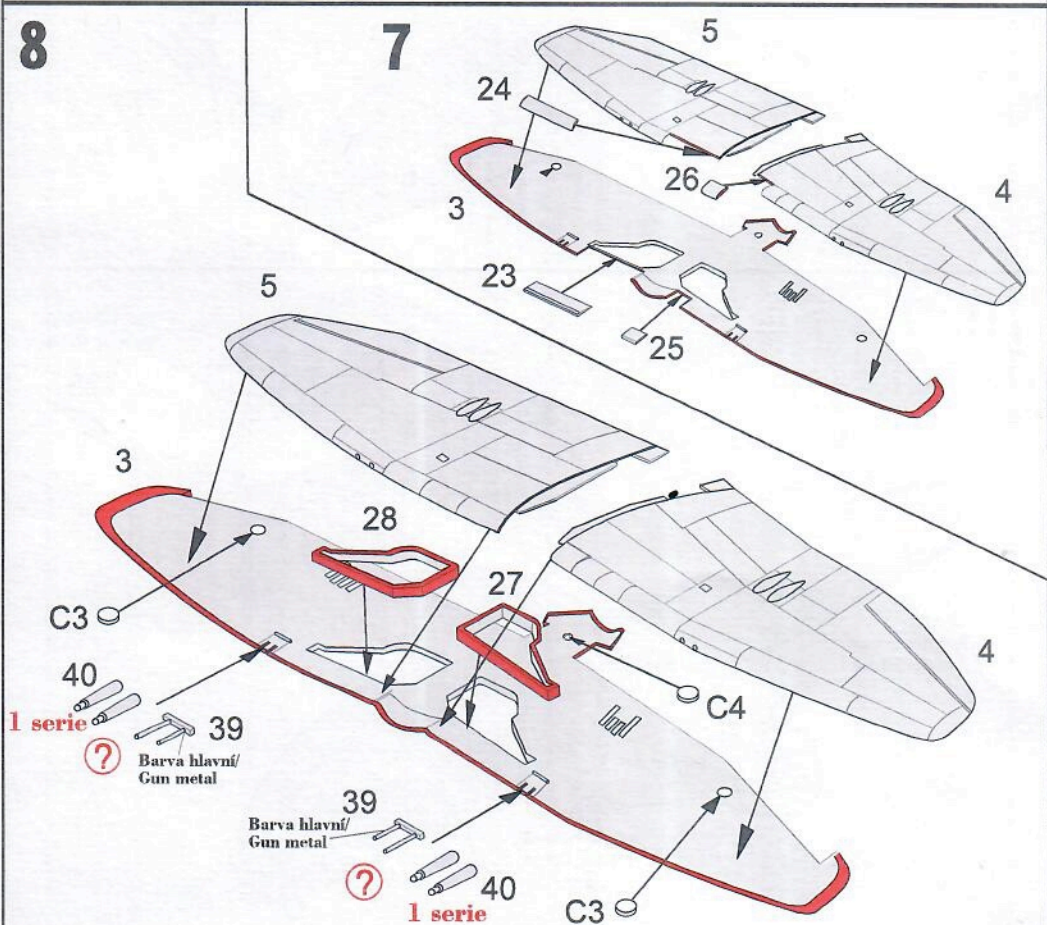

9

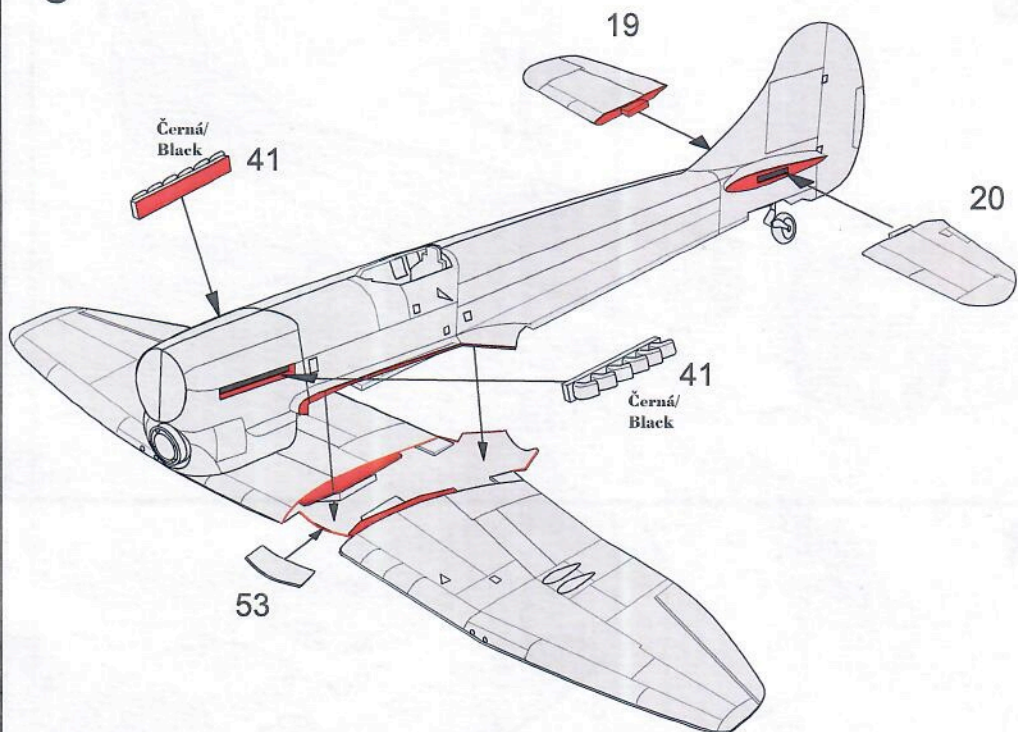

10

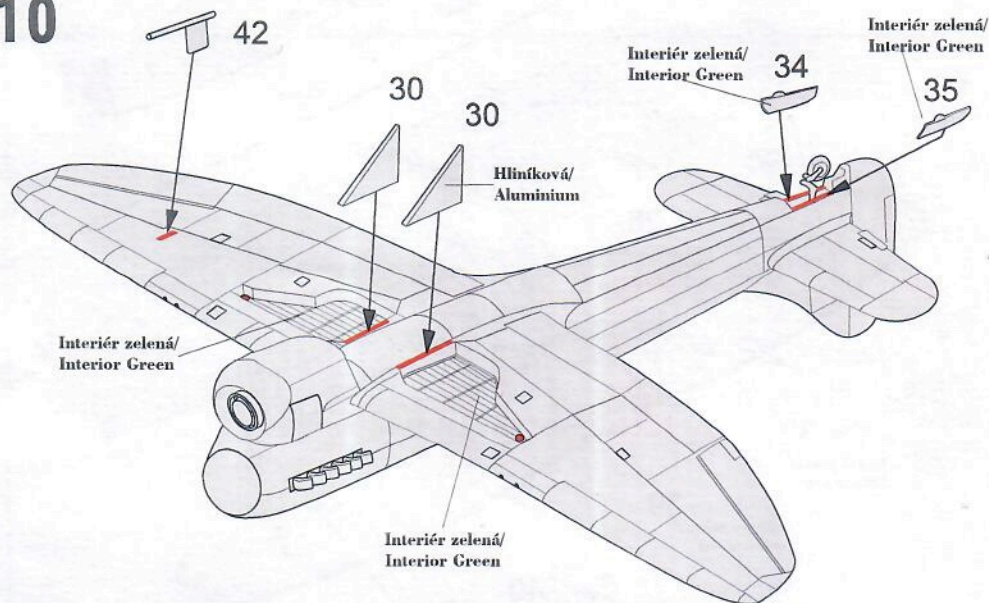

# 11

Interiér zelená/  
Interior Green

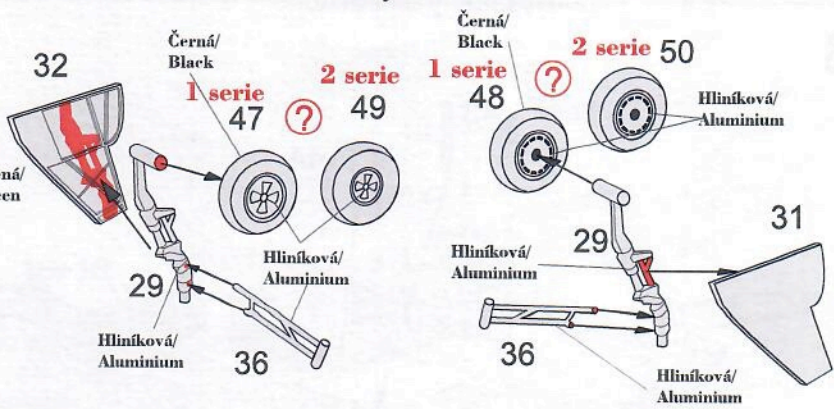

# 12

Interiér zelená/  
Interior Green

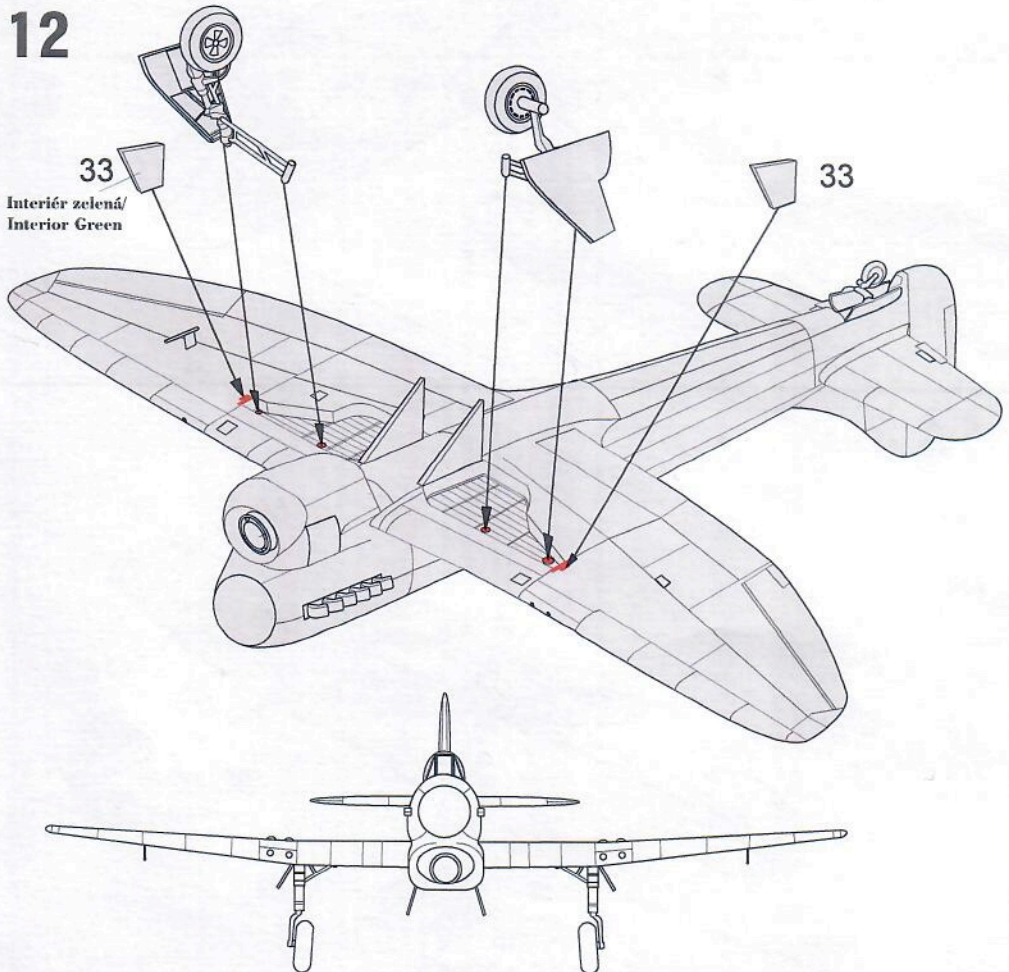

13

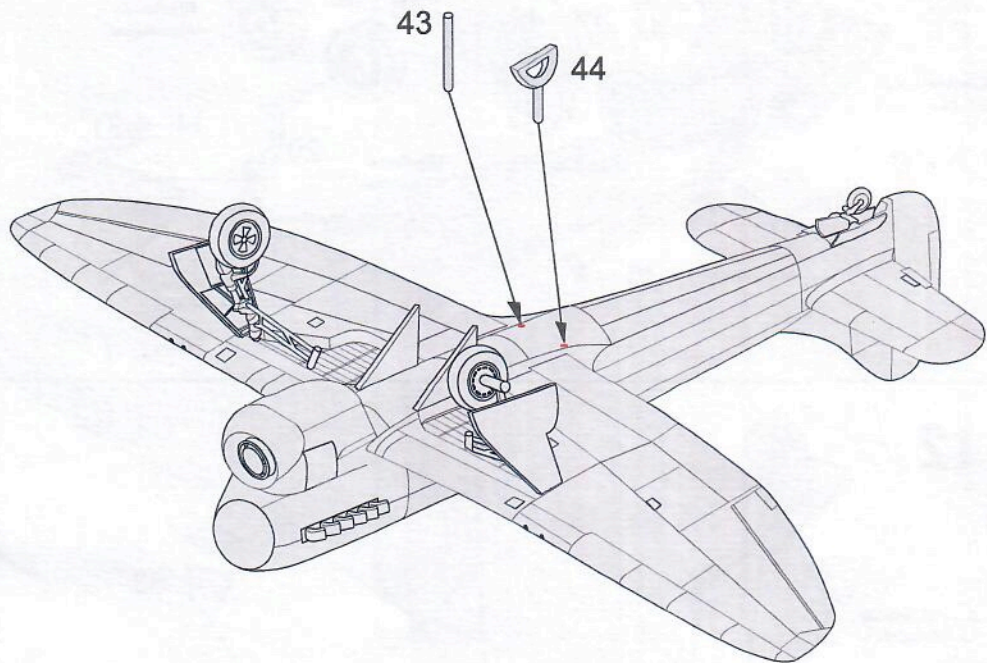

14

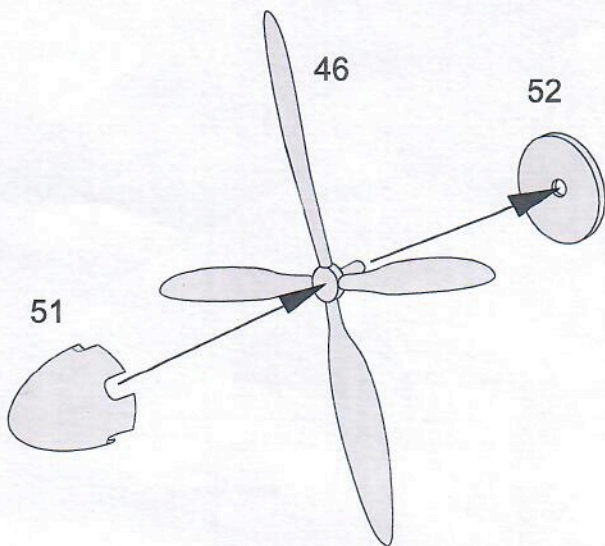

15

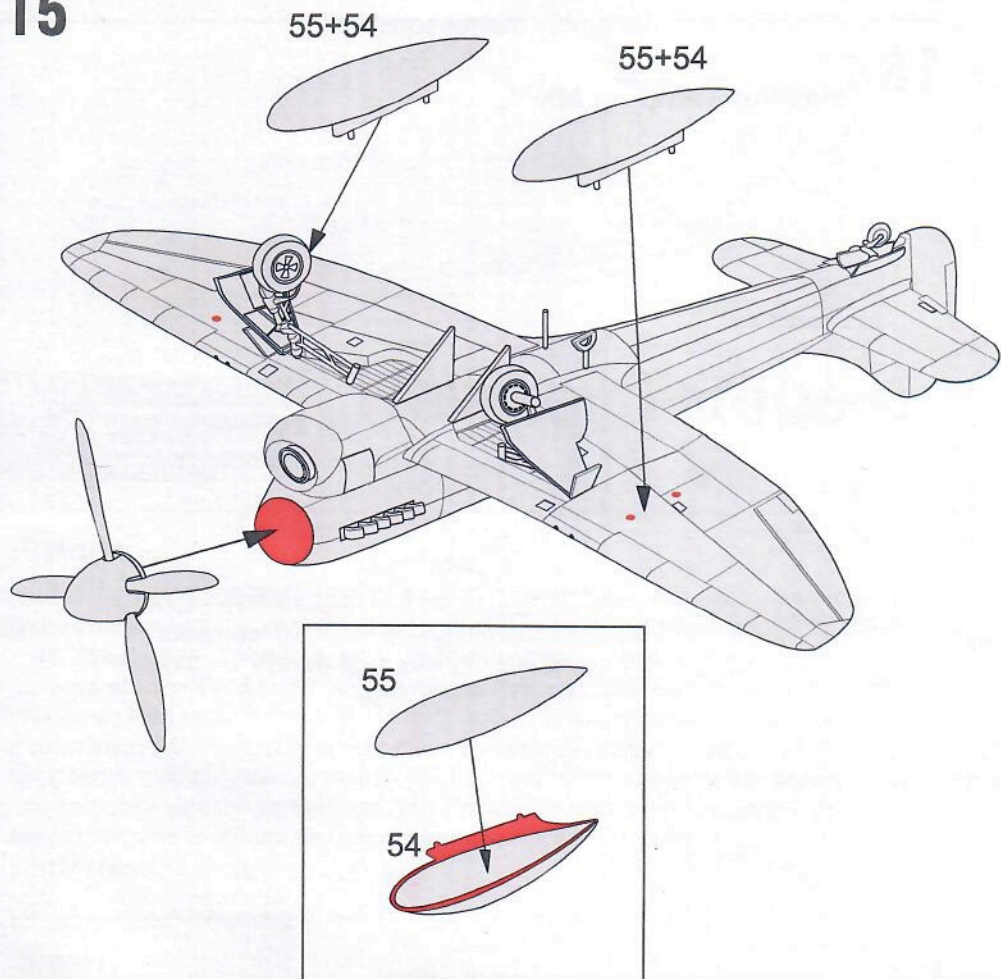

16

C1+C2

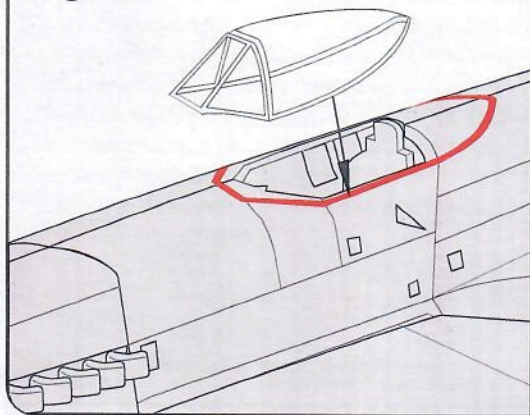

17

C1 C2

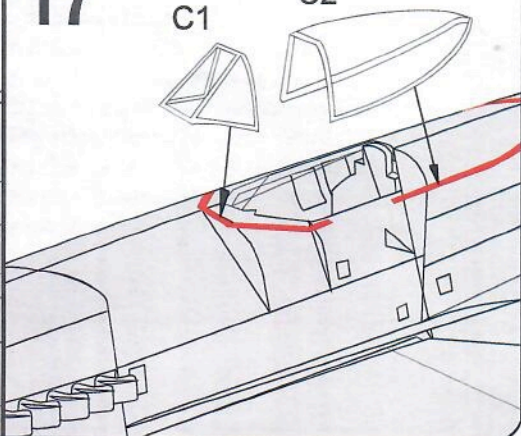

18

Hawker Tempest Mk V

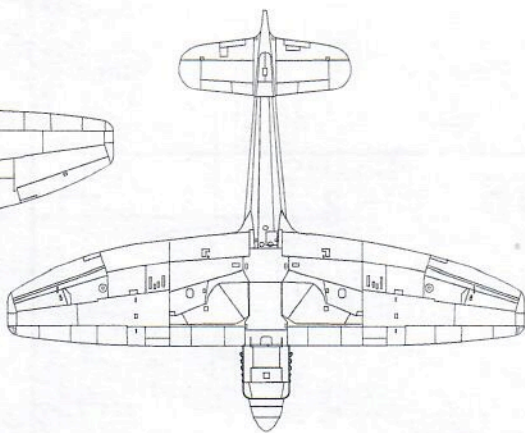
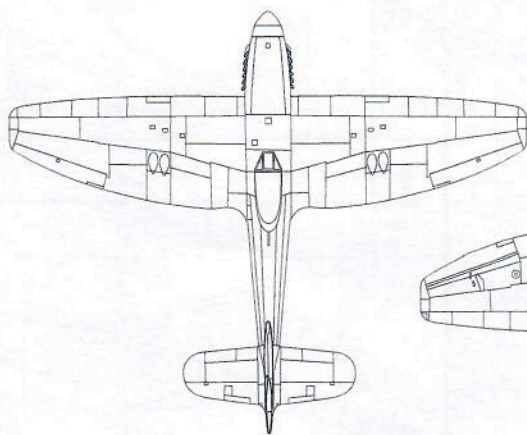
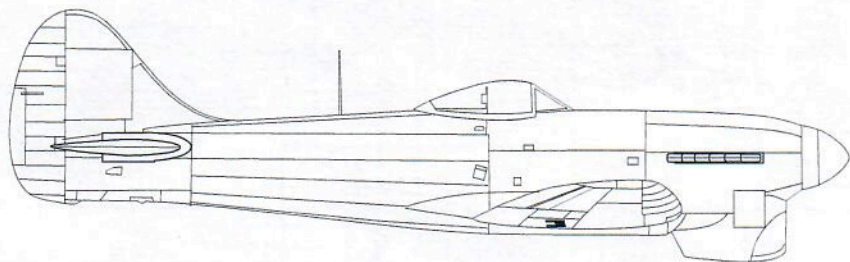
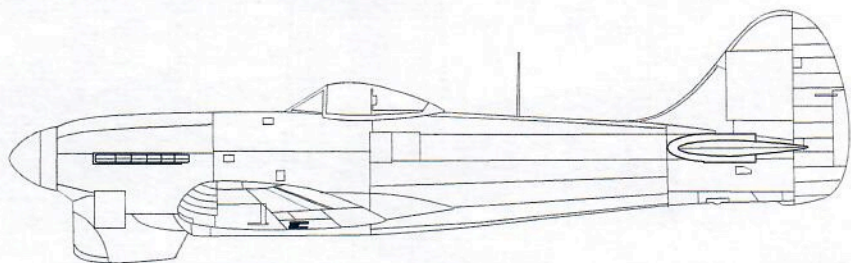



## Colours & Markings

1

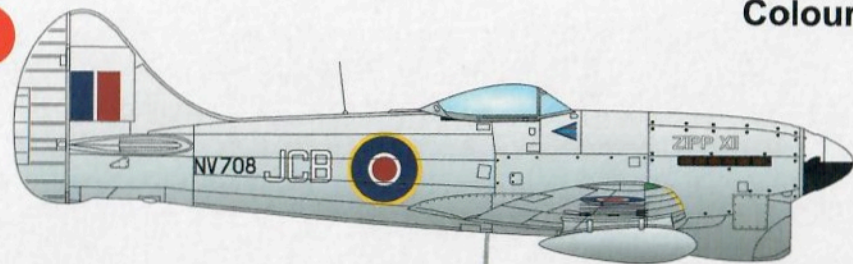

Hawker Tempest Mk. V series 2, NV708, JCB, pilot W/Cdr. John Chester Button, 123. wing, základna Wunstorf, Německo, 1946.  
Hawker Tempest Mk. V series 2, NV708, JCB, flown by W/Cdr. John Chester Button, No 123 Wing, RAF Wunstorf, Germany, 1946.

56

Hliník  
Aluminium

24

Zlutá  
Yellow



27

Tmavá šedá  
Ocean Grey

vtule/propeller

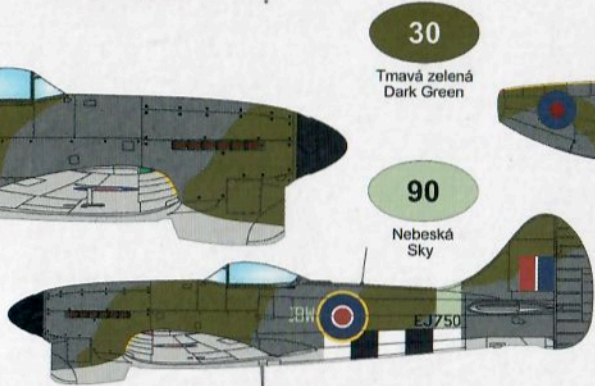
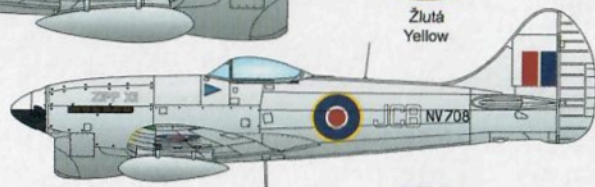

30

Tmavá zelená  
Dark Green

90

Nebeská  
Sky



64

Světlá šedá  
Medium Sea Grey

vtule/propeller

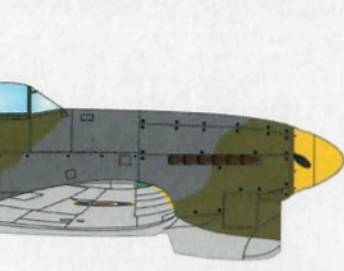
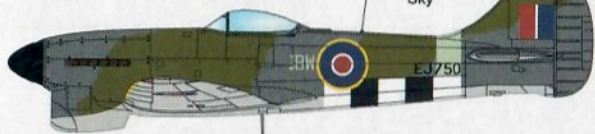

33

Černá  
Black

113

Výfuky  
Exhausts



34

Bílá  
White

vtule/propeller



Paints used:

**HUMBROL**

2

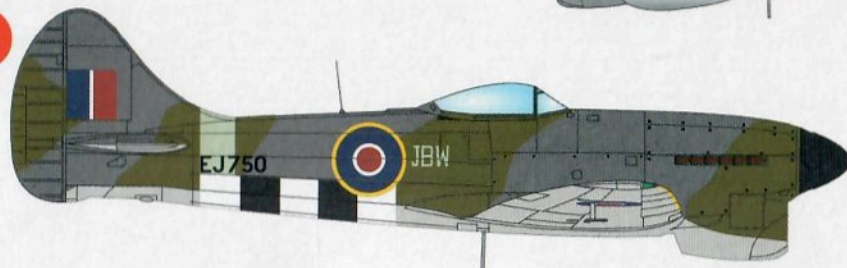

Hawker Tempest Mk. V series 2, EJ750, JBW, pilot W/Cdr John B. Wray, velitel 122. wingu, základna Volkel, Nizozemí, prosinec 1944.  
Hawker Tempest Mk. V series 2, EJ750, JBW, flown by W/Cdr John B. Wray, CO of No 122 Wing, Volkel AB, Netherlands, December 1944.

3

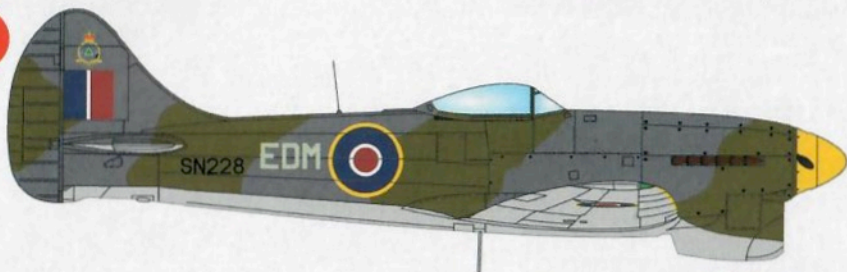

Hawker Tempest Mk. V series 2, SN228, EDM, pilot W/Cdr Ewan D. Mackie, velitel 122. wingu, základna Kastrup, Dánsko, léto 1945.  
Hawker Tempest Mk. V series 2, SN228, EDM, flown by W/Cdr Ewan D. Mackie, CO of No. 122 Wing, Kastrup AB, Denmark, late summer 1945.