

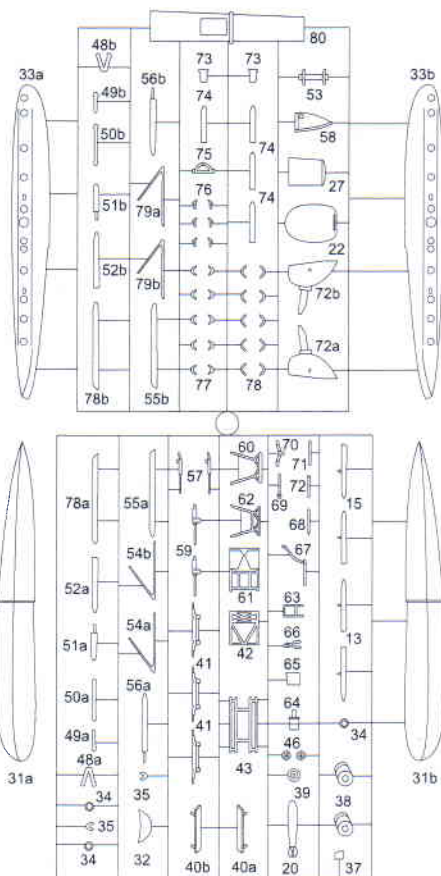

92281

The Dornier Do 22 was a German seaplane, developed in the 1930s. Despite good performance, it was built only in small numbers and entirely for the export market. The type was operated in the Second World War by Greece, Yugoslavia and Finland. The first production model, known as the Do 22/See when fitted with floats, did not fly until 15 July 1938 from Dornier's factory at Friedrichshafen, Germany, although it did incorporate parts made in Switzerland. While the Luftwaffe was not interested in the aircraft, examples were sold to Yugoslavia, Greece and Latvia.

PLASTIC PARTS

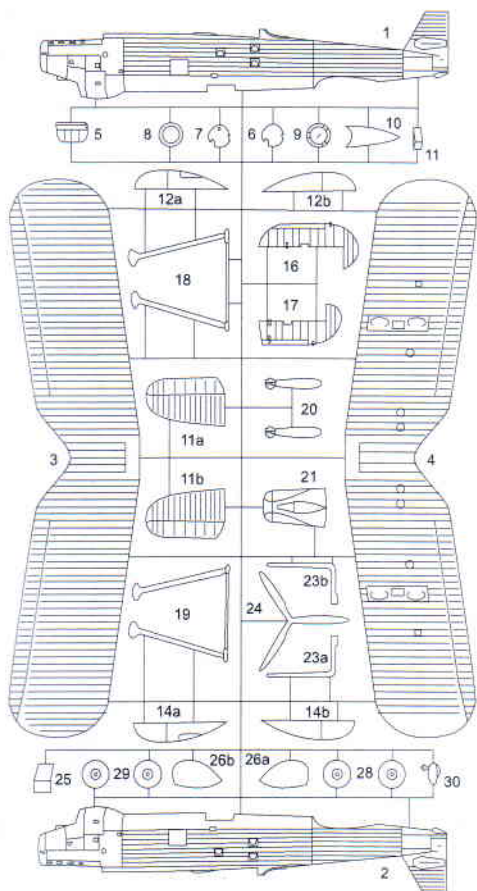

PHOTOETCHED PARTS (PP)



CLEAR PARTS (CP)



INSTRUMENTS (I)



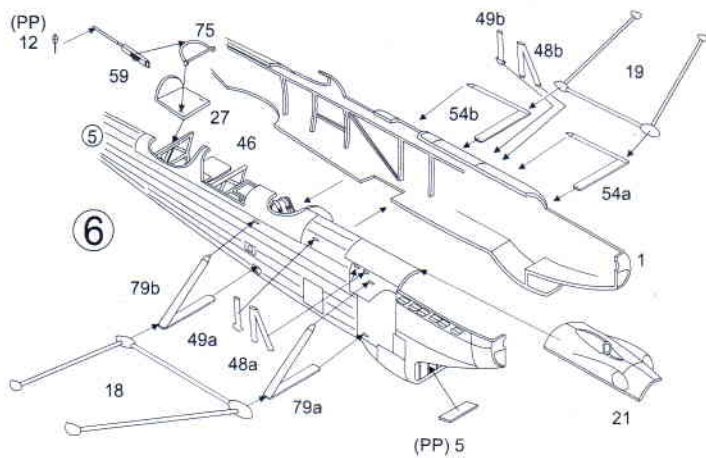
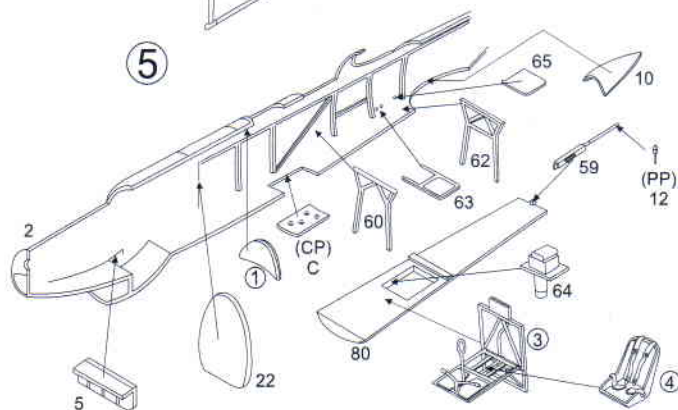
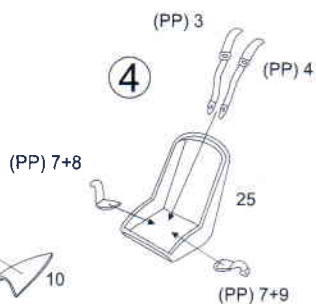
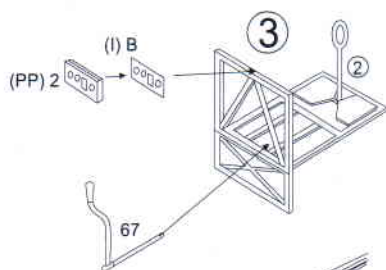
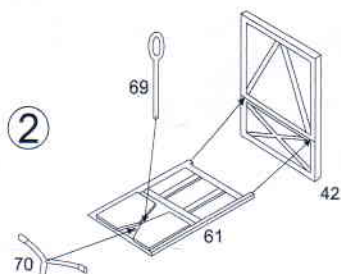
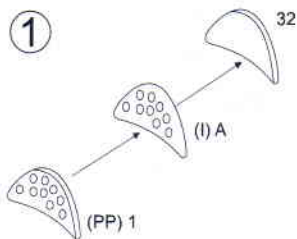

PART 16+58 - Marking no. 1 and 4
PART 17 - Marking no. 2 and 3

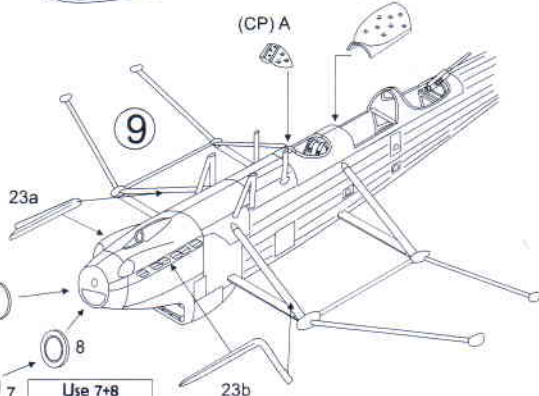
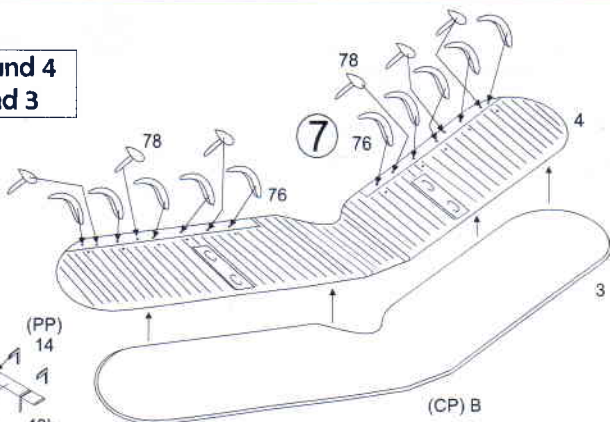
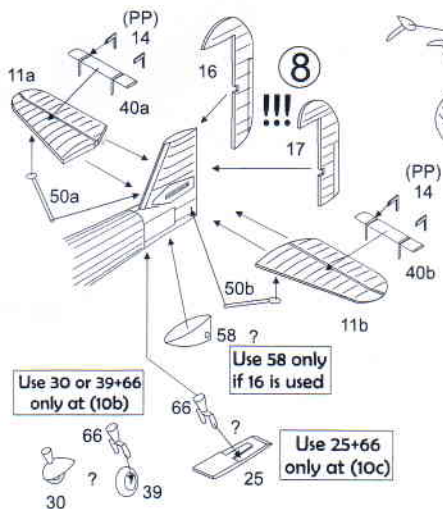

10a. Do 22
Float version

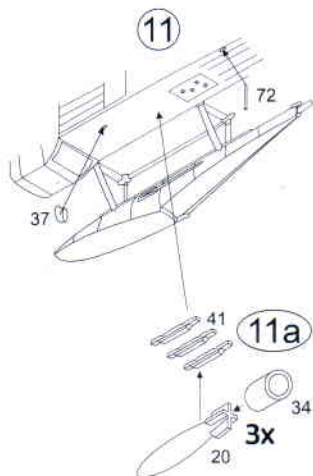
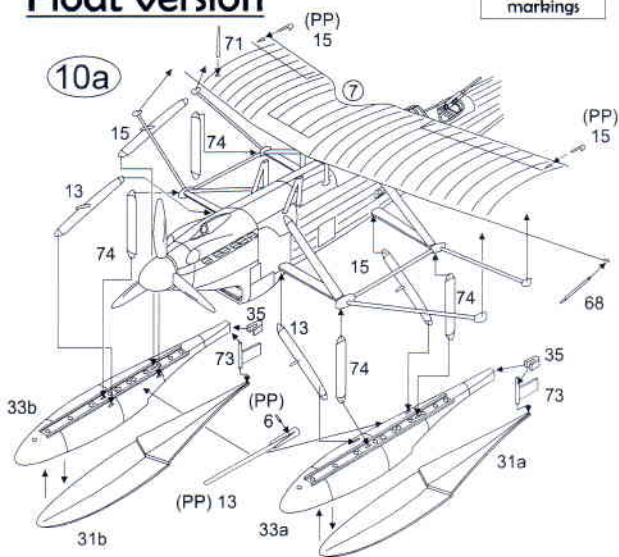

10b. Do 22 Wheels version

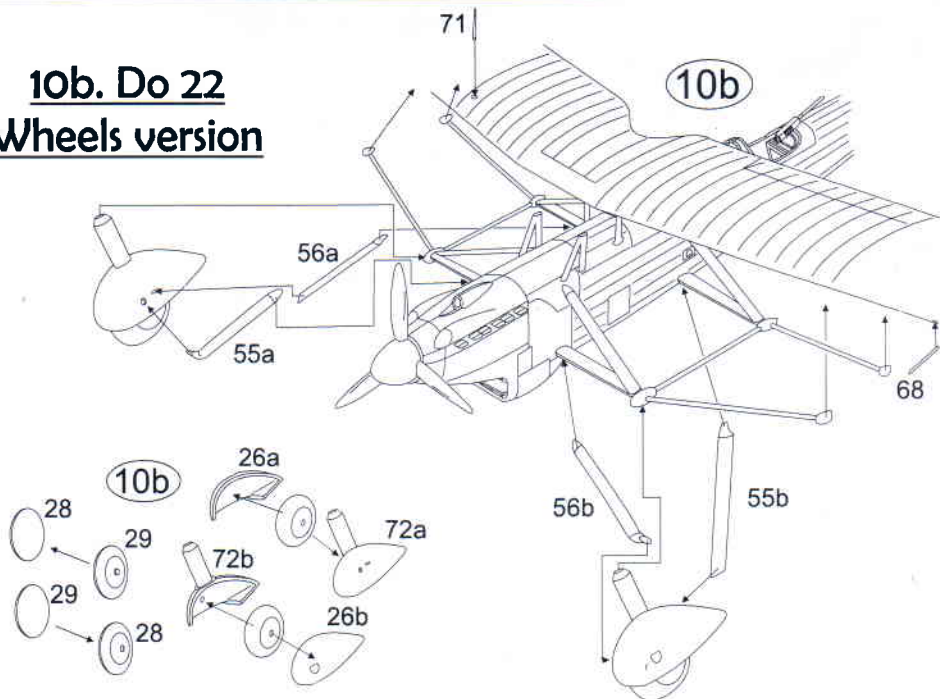

10c. Do 22 Ski version

