

# Combat Trainers

## 2 in 1: PZL 23 A Karaś and PZL P.11a



Cat. No. 72529  
Scale 1/72



3d design: Przemysław Głogowski  
Research: IBG Crew



**Element złożony we wcześniejszym etapie**  
*Element assembled in previous step*



**Element po złożeniu w aktualnym etapie**  
*Element after assembly in current step*



**Wersja do wyboru**  
*Version to choose*



**Kolor farby**  
*Paint colour*



**Kalkomania**  
*Decal*

### Kalkomanie / Decals



	VALLEJO	HATAKA	LIFE COLOR	MR HOBBY	AK INTERACTIVE	MISSION MODELS	
Polish Khaki	A	71.024	HTK-_011	TM008	H81	AK4042	MMP-123
Black	B	71.057	HTK-_100	LC02	H12	RC001	MMP-047
White	C	71.001	HTK-_101	LC01	H21	AK738	MMP-001
Silver	D	71.067	HTK-_003	LC24	H8	AK479	MMP-006
Rust	E	71.130	HTK-_132	LC32	H47	AK708	MMW-001
Light Blue-Grey	F	71.046	HTK-_036	TM009	H67	RC239	MMP-096
Brown Leather	G	72.740	HTK-_186	UA764	H460	AK3031	MMP-002
Black Leather	H	71.057	HTK-_100	UA763	H12	AK3034	MMP-040
Gunmetal	J	71.072	HTK-_106	LC26	H018	AK798	MMM-010
Light Brown	K	71.027	HTK-_074	UA767	H455	AK787	MMP-131

**Przed montażem przeczytać instrukcję. Przestrzegać kolejności montażu podanego w instrukcji. Klej i farby nie wchodzą w skład zestawu.**  
*Please read instructions before assembly. Follow the sequence of assembly presented in instructions. Glue and paint not included.*

IBG Models  
ul. Benedykta Hertza 2  
04-603 Warszawa  
Poland

tel +48 22 8159150  
fax +48 22 8159151  
ibgsc@ibg.com.pl  
www.ibg.com.pl  
www.ibgmodels.com

Ramka A / Frame A

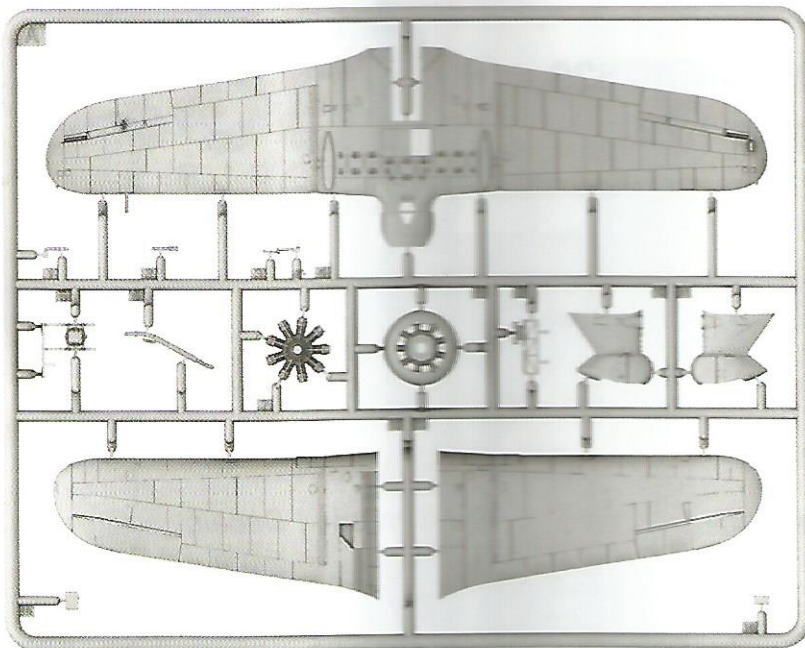

Ramka B / Frame B

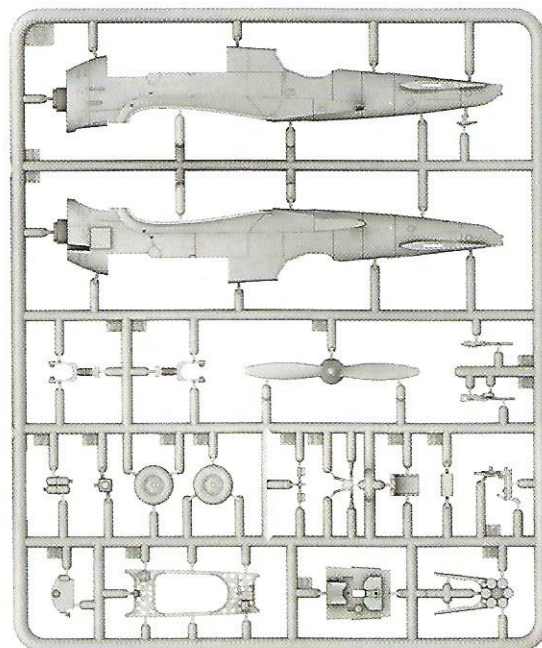

Ramka C / Frame C

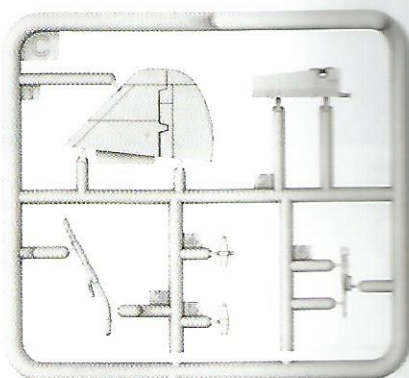

Ramki F, H i M / Frames F, H and M

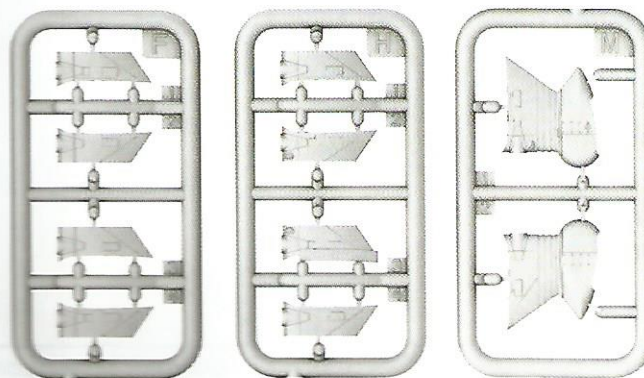

Ramka K / Frame K

Przezroczysta / Transparent

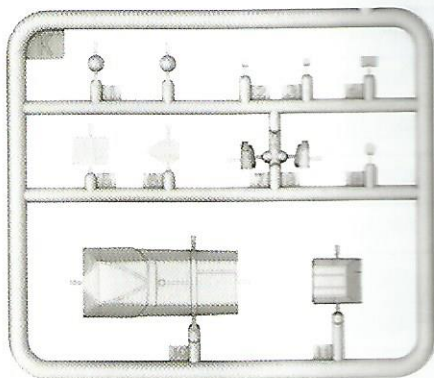

Ramka N / Frame N

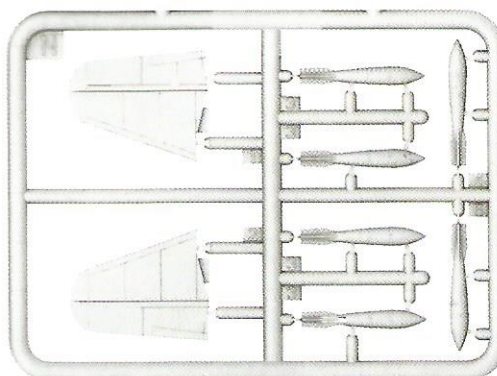

Elementy Fototrawione / Photo-etched Parts

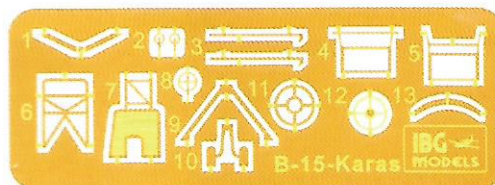

Ramka A / Frame A

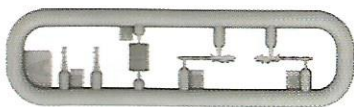

Ramka B / Frame B

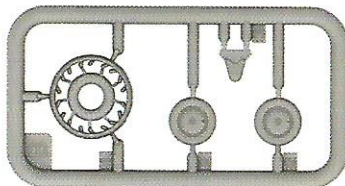

Ramka J / Frame J

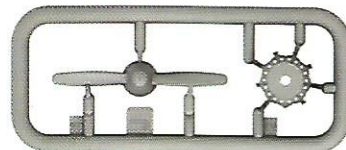

Ramka C / Frame C

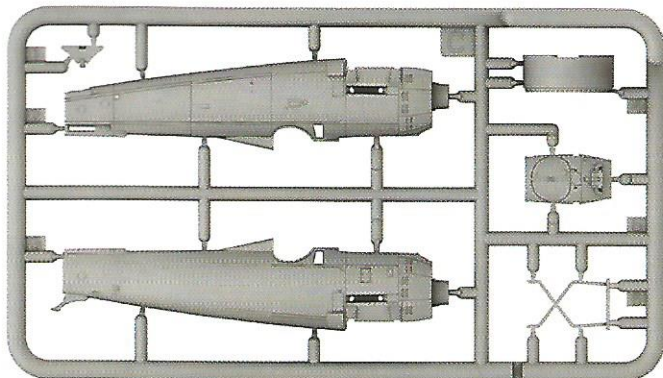

Ramka N / Frame N

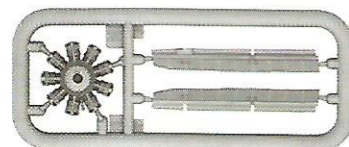

Ramka R / Frame R

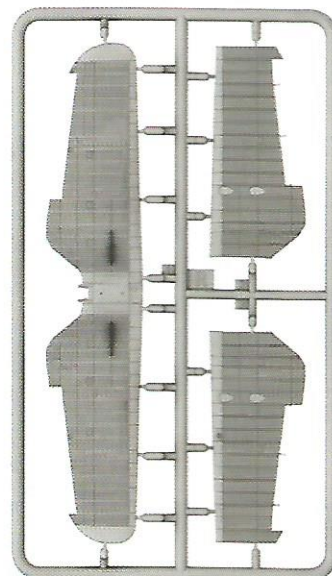

Ramka K przezroczysta / Frame K transparent



Ramka T / Frame T

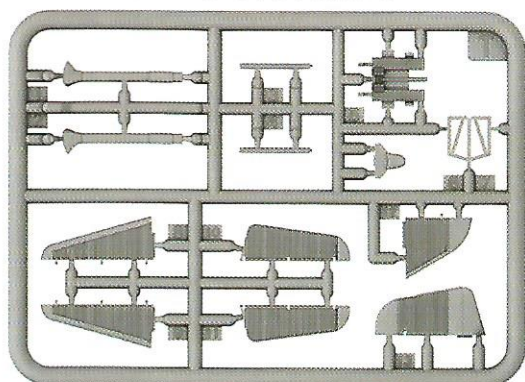

Ramka V / Frame V

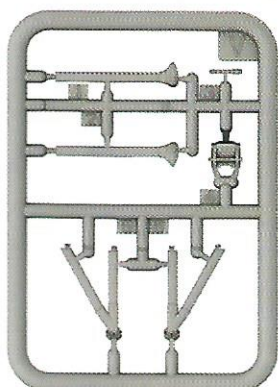

Elementy Fototrawione / Photo-etched Parts

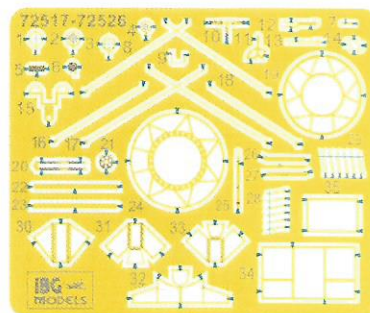

**Etap 1**  
*Step 1*

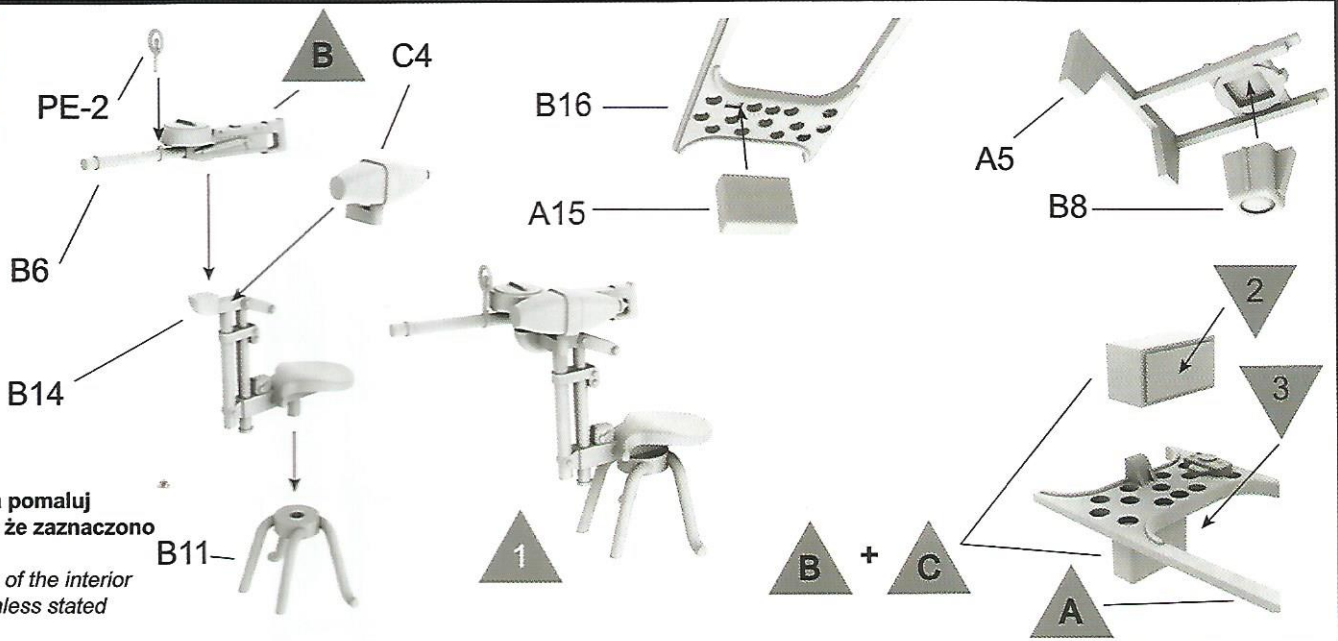

**Etap 2**  
*Step 2*

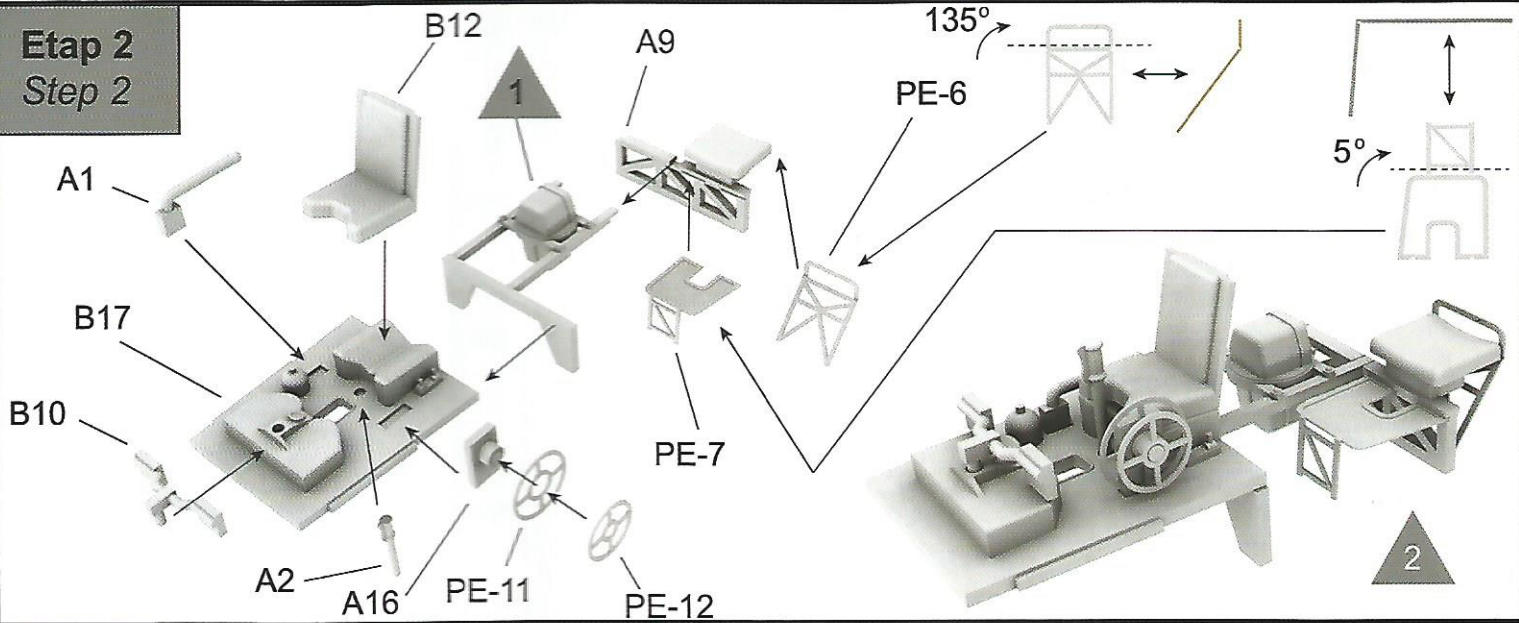

**Etap 3**  
*Step 3*

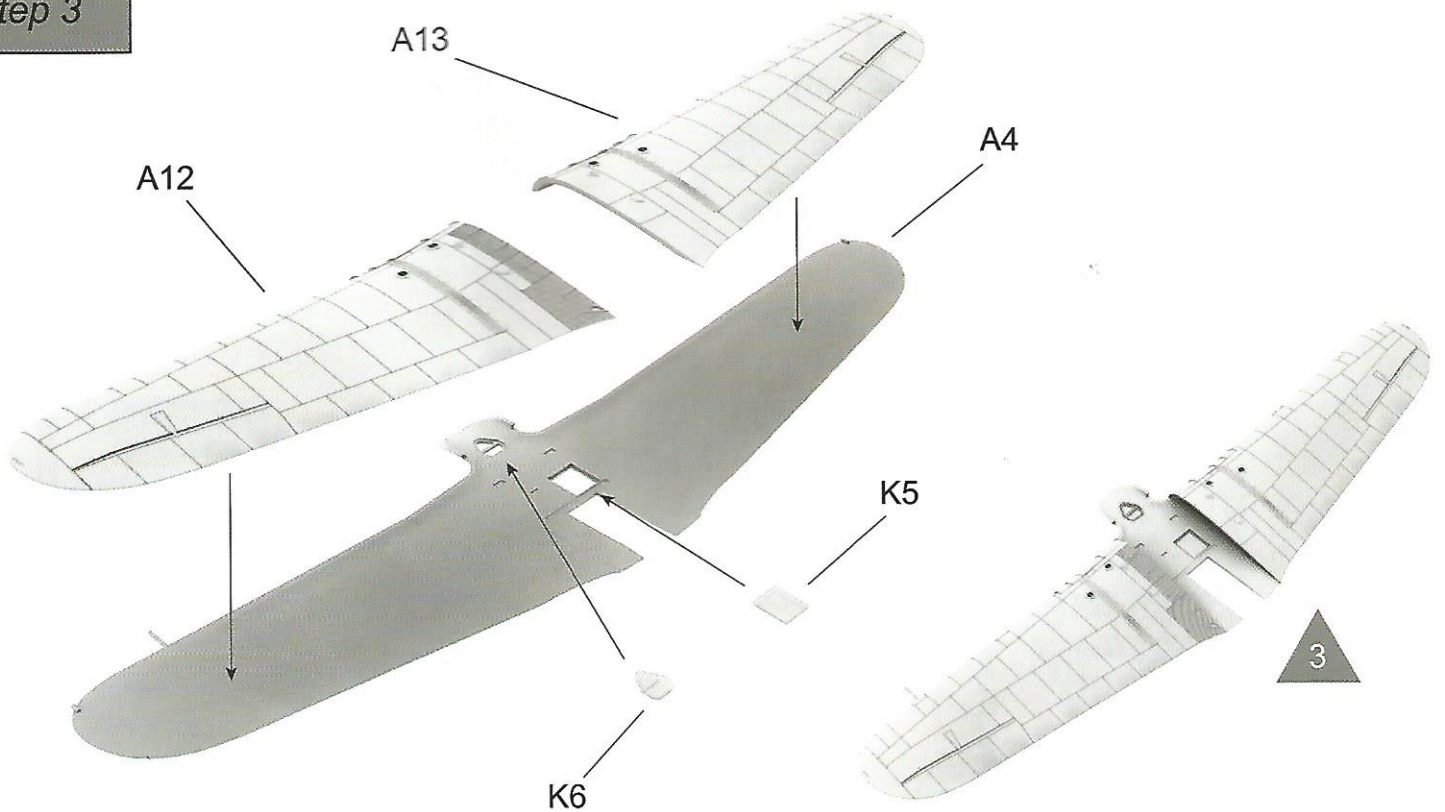

**Etap 4**  
*Step 4*

PE-10

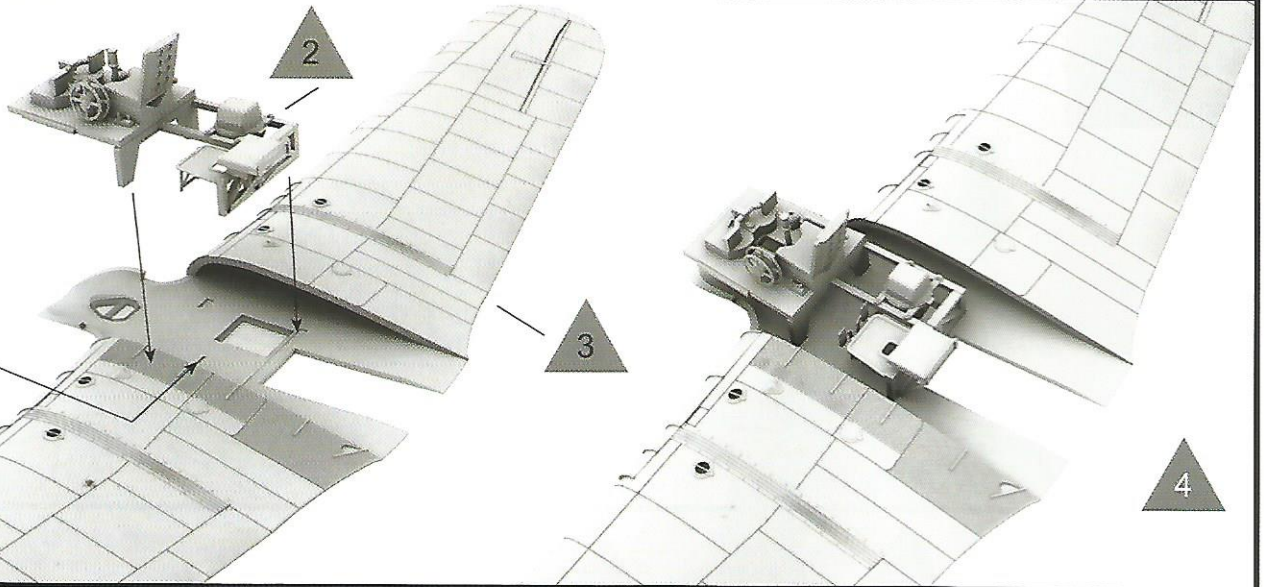

**Etap 5**  
*Step 5*

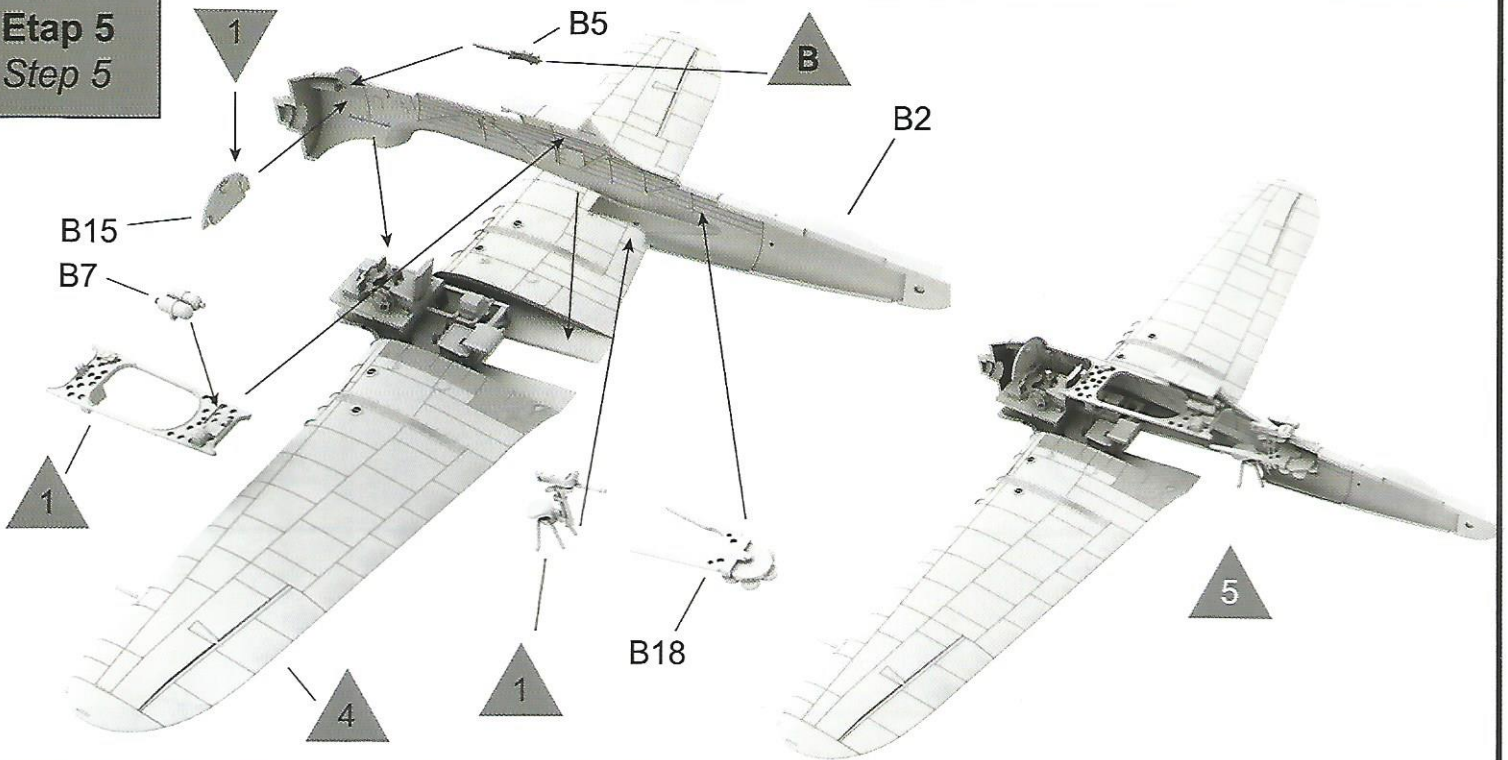

**Etap 6**  
*Step 6*

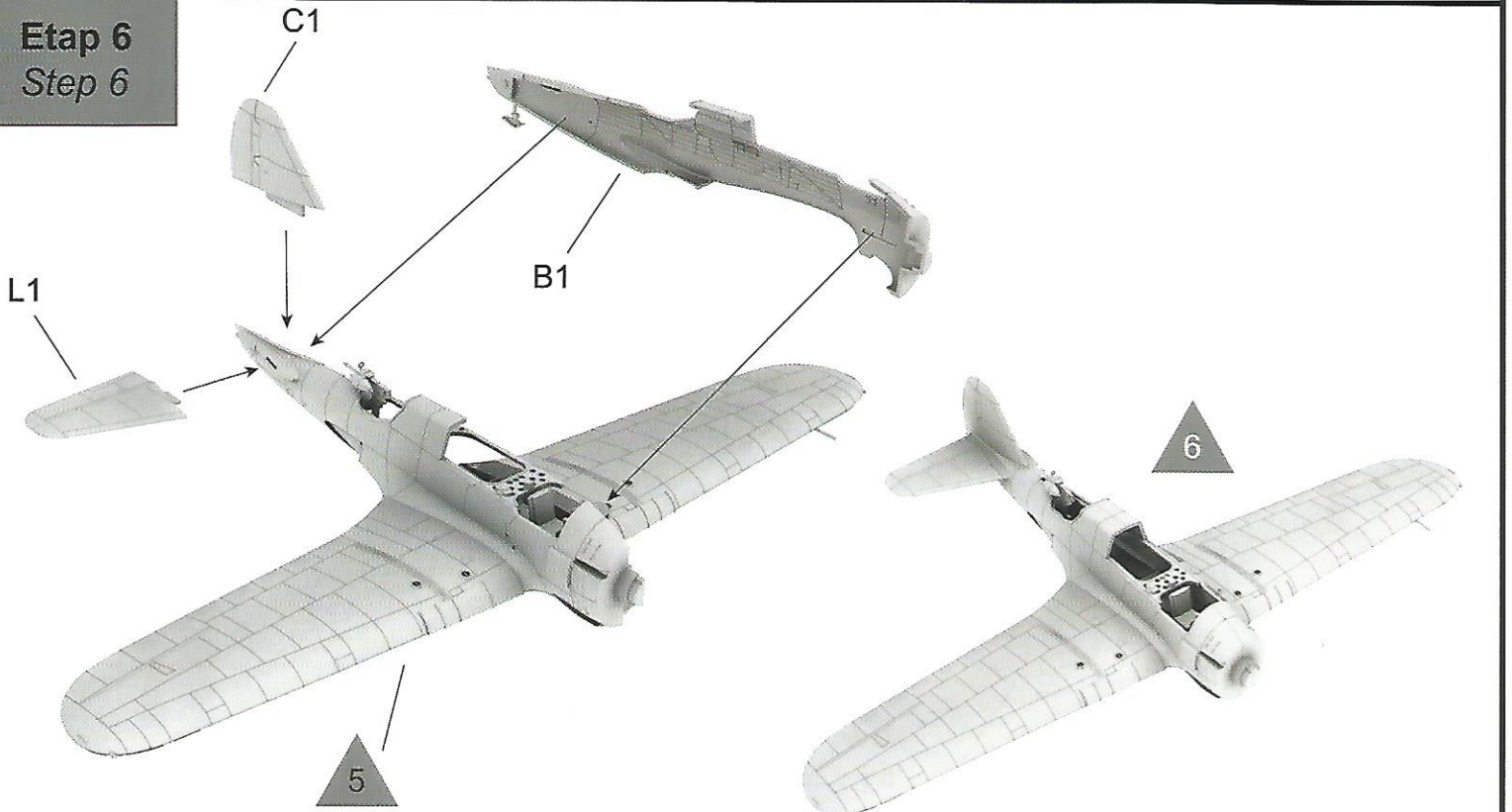

**Etap 7**  
*Step 7*

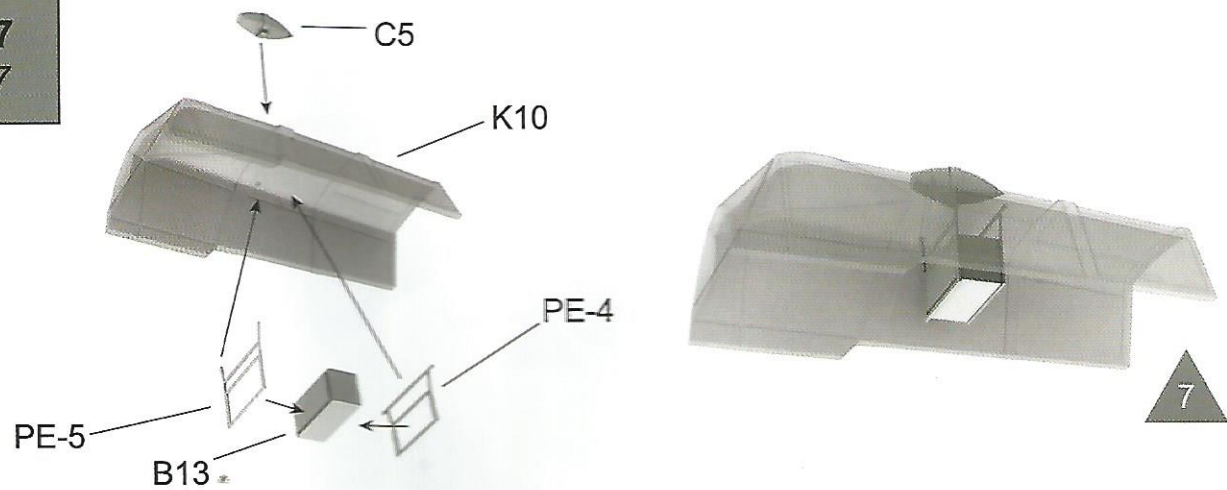

**Etap 8**  
*Step 8*

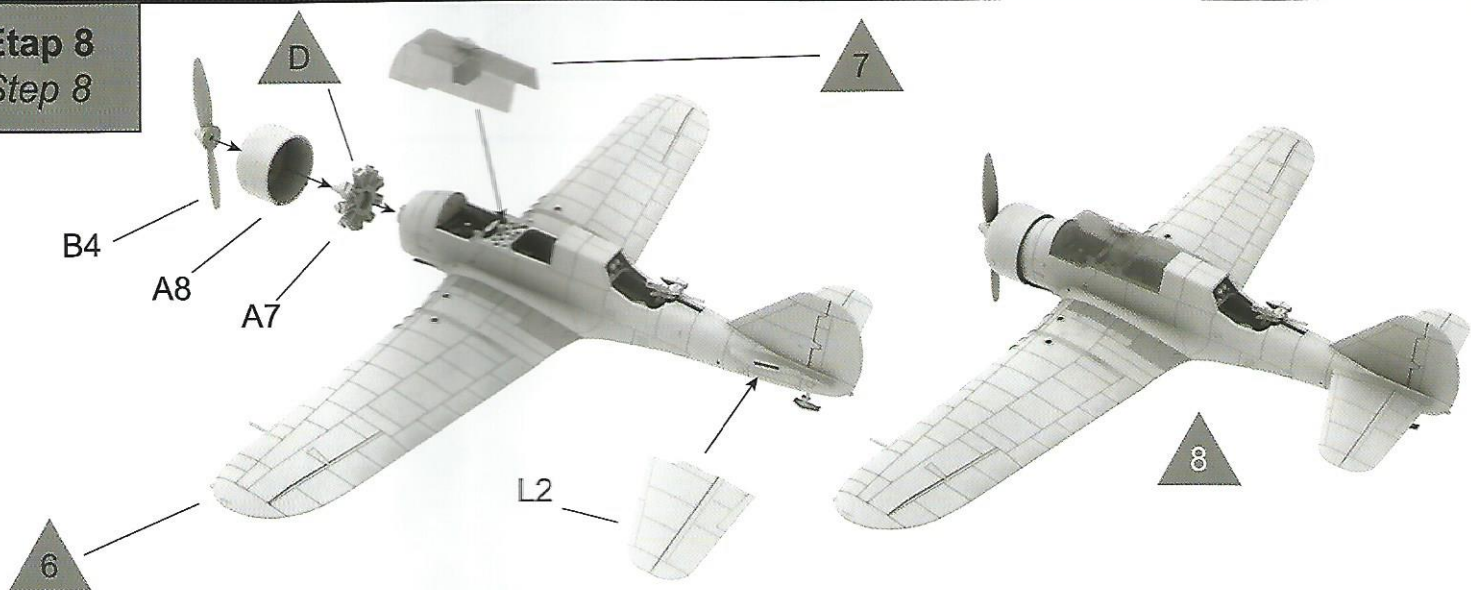

**Etap 9**  
*Step 9*

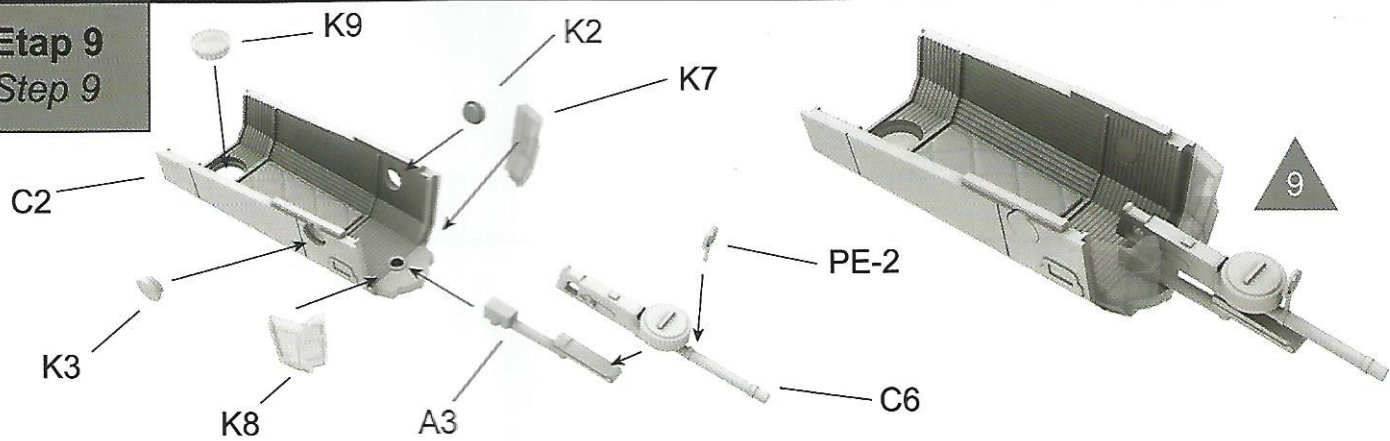

**Etap 10**  
*Step 10*

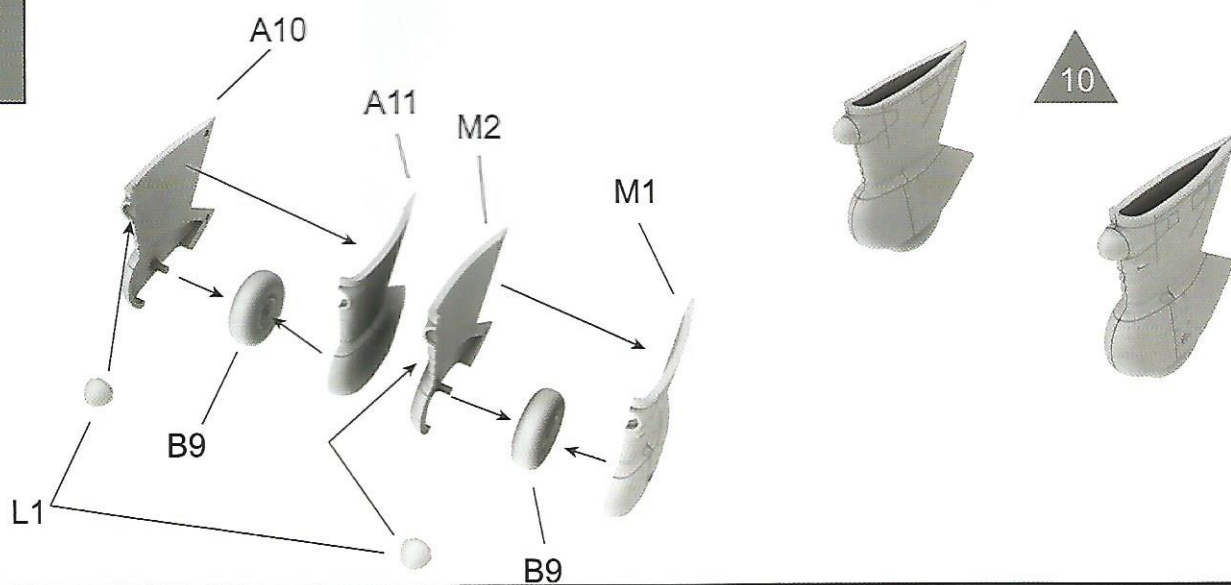

**Etap 11**  
**Step 11**

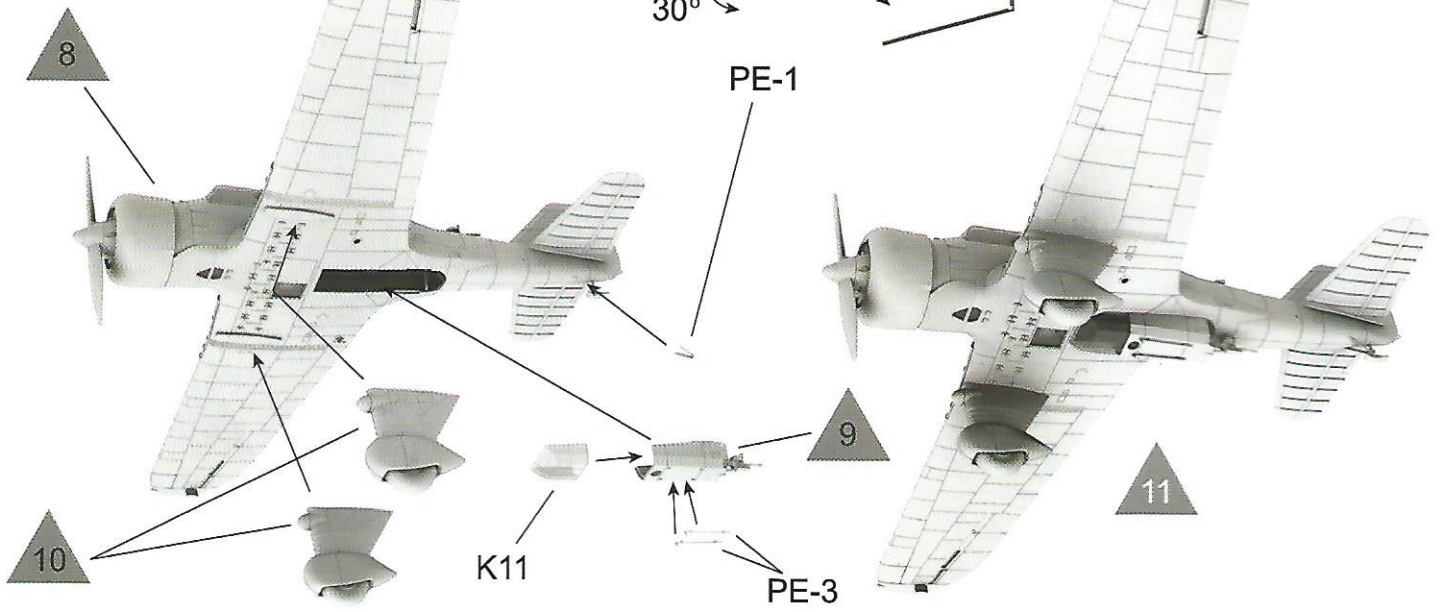

**Etap 12**  
**Step 12**

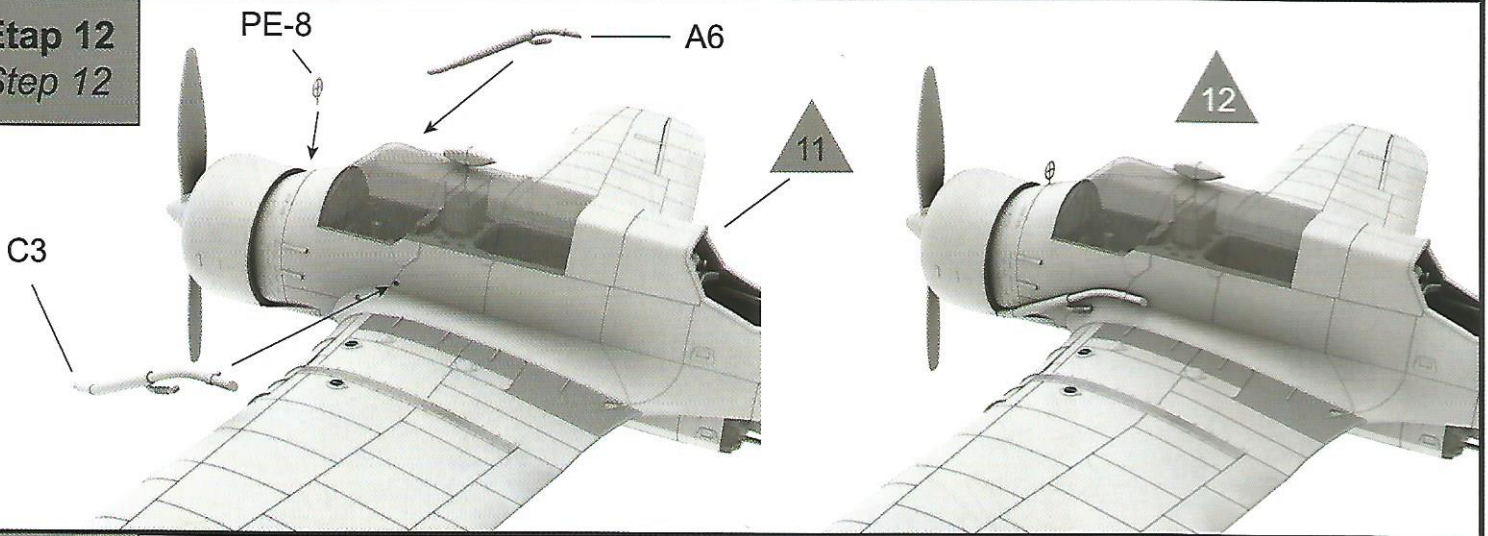

**Etap 13**  
**Step 13**

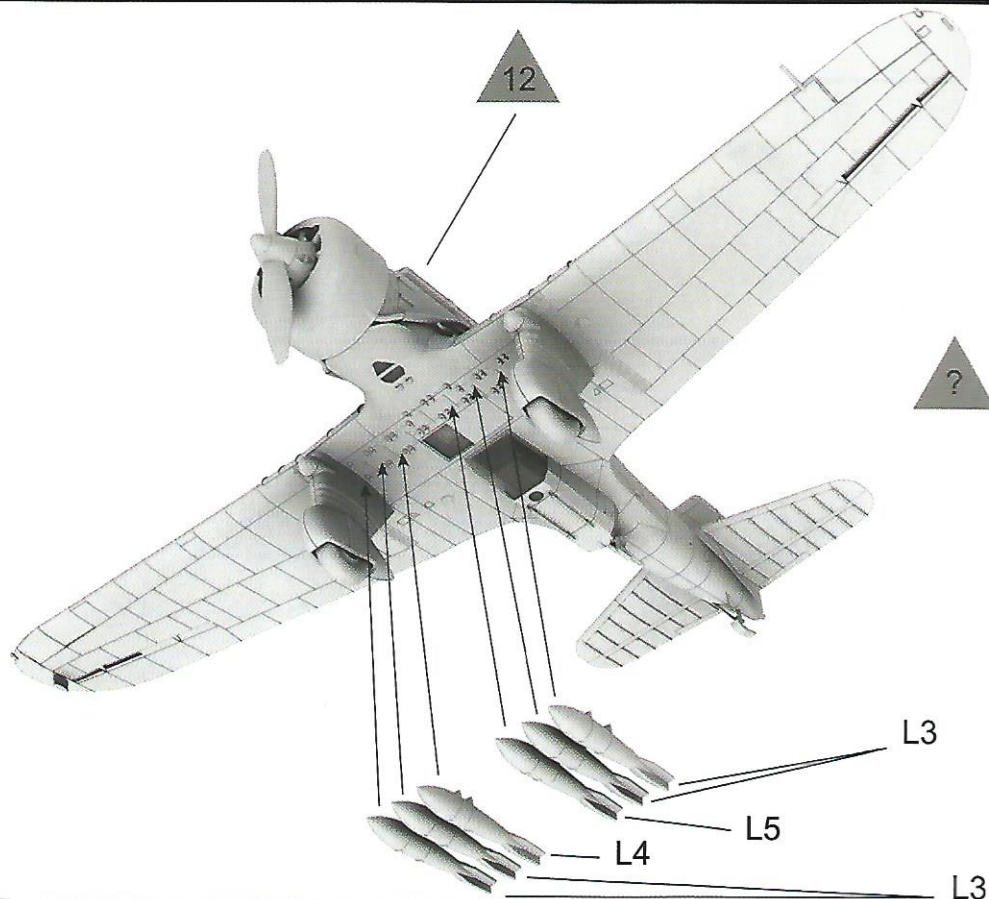

**?** Krok opcjonalny  
Optional Step

**Malowanie wnętrza P.11a**  
*Painting of the interior of P.11a*

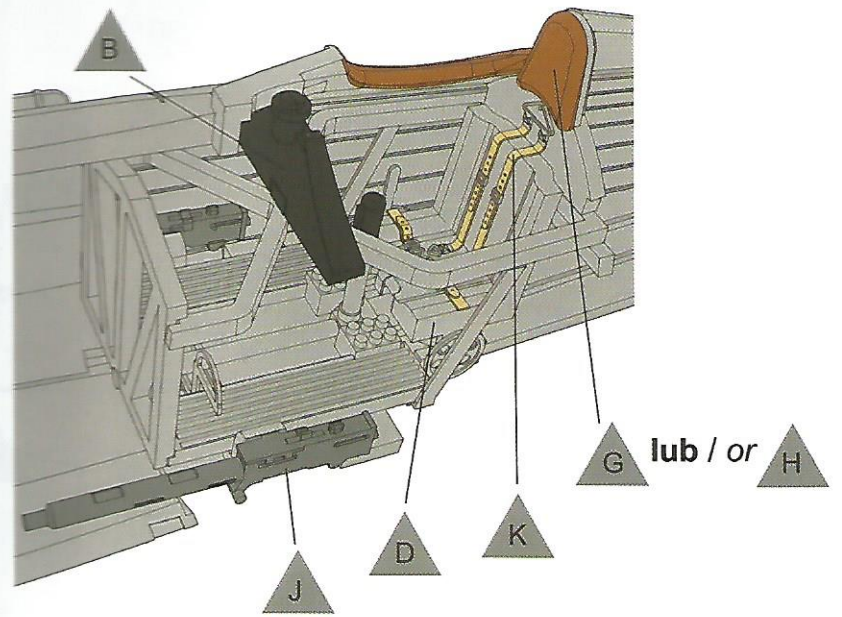

**Etap 1**  
*Step 1*

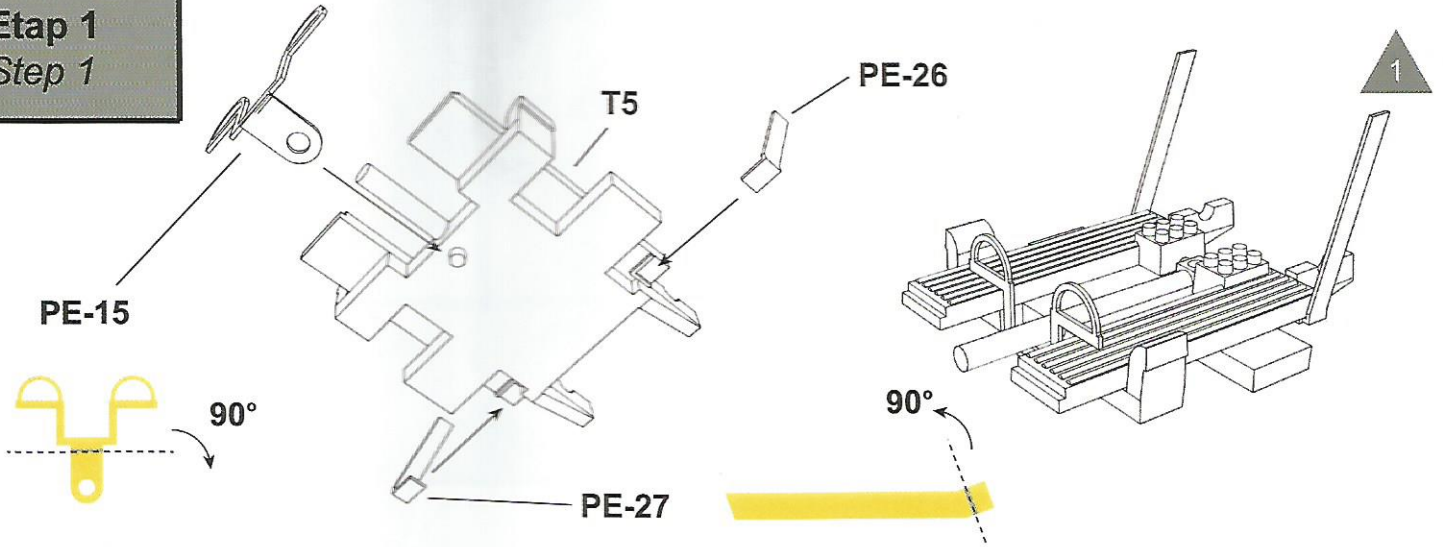

**Etap 2**  
*Step 2*

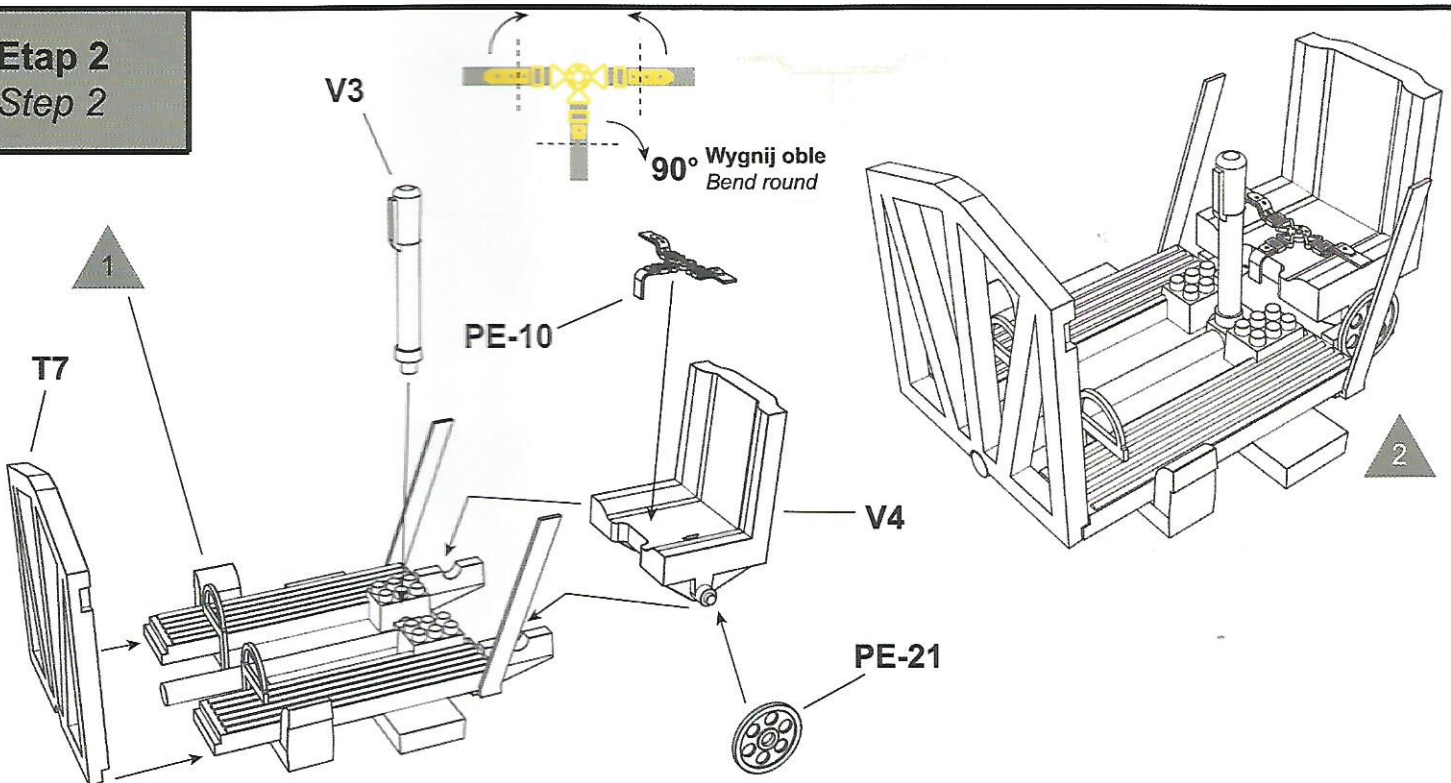



**Etap 3**  
*Step 3*

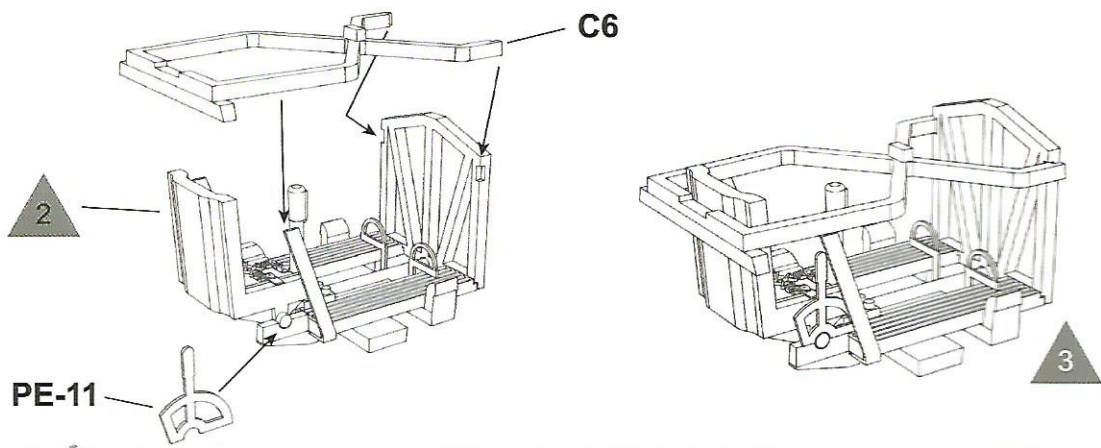

**Etap 4**  
*Step 4*

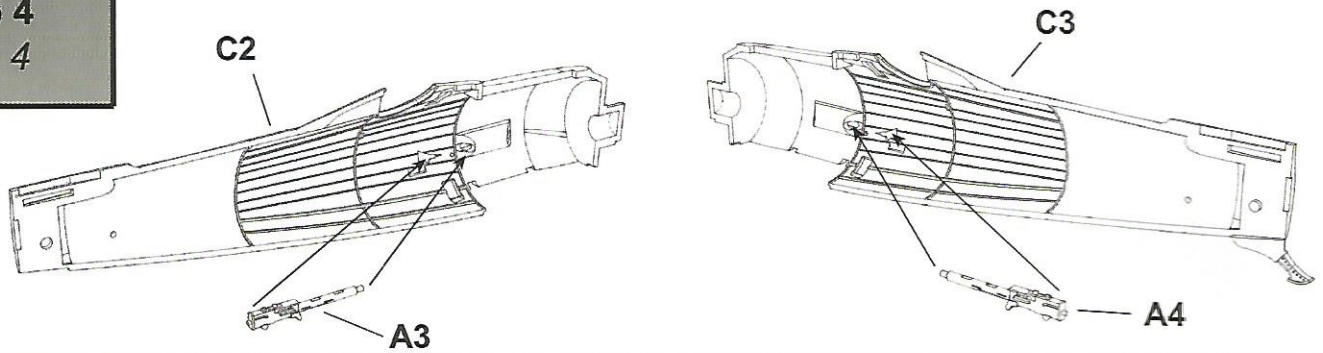

**Etap 5**  
*Step 5*

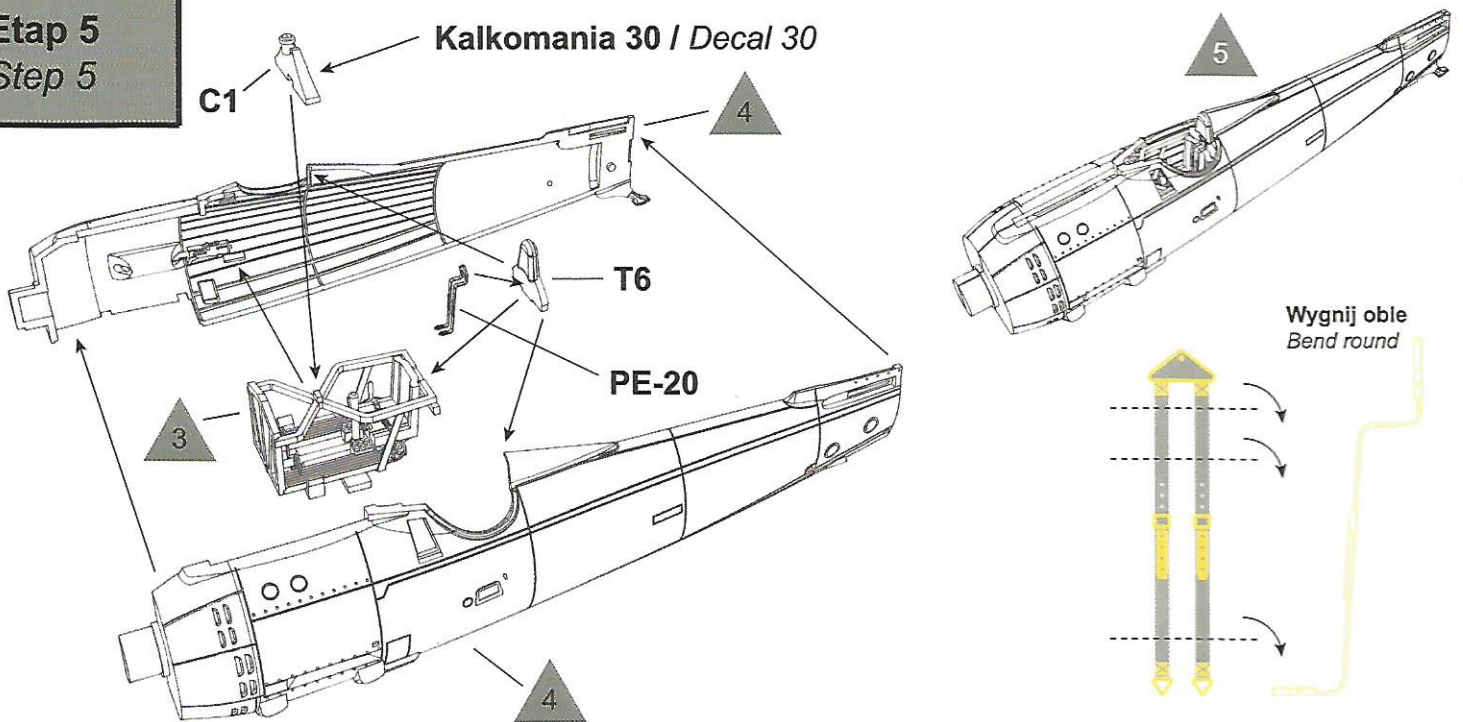

**Etap 6**  
*Step 6*

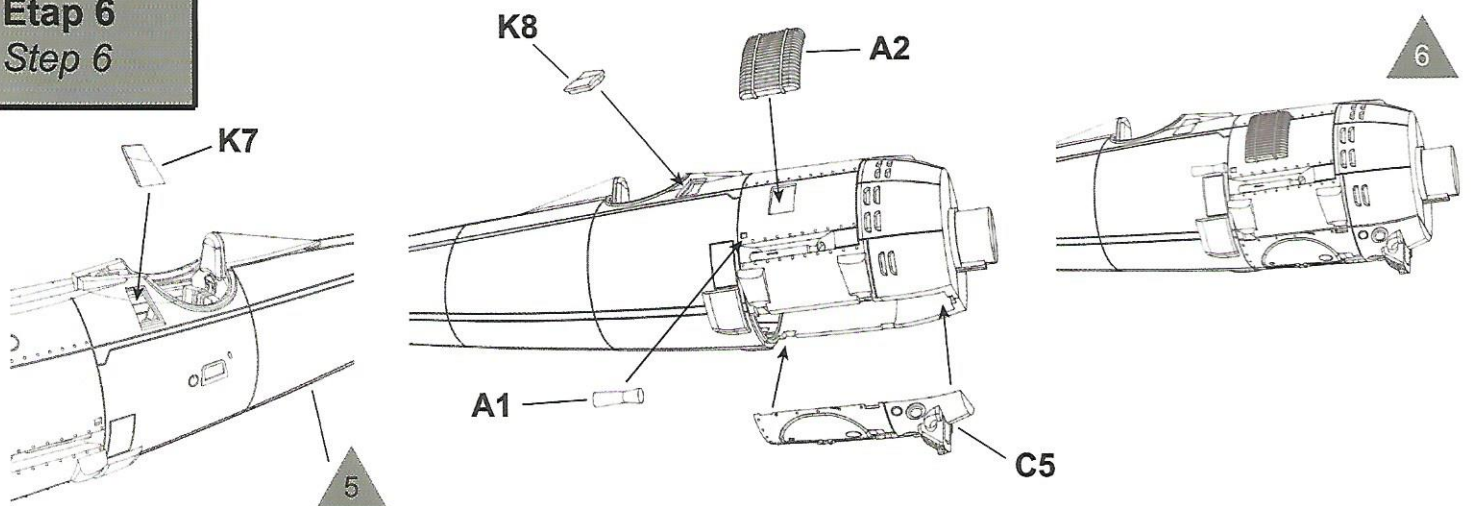

**Etap 7**  
Step 7

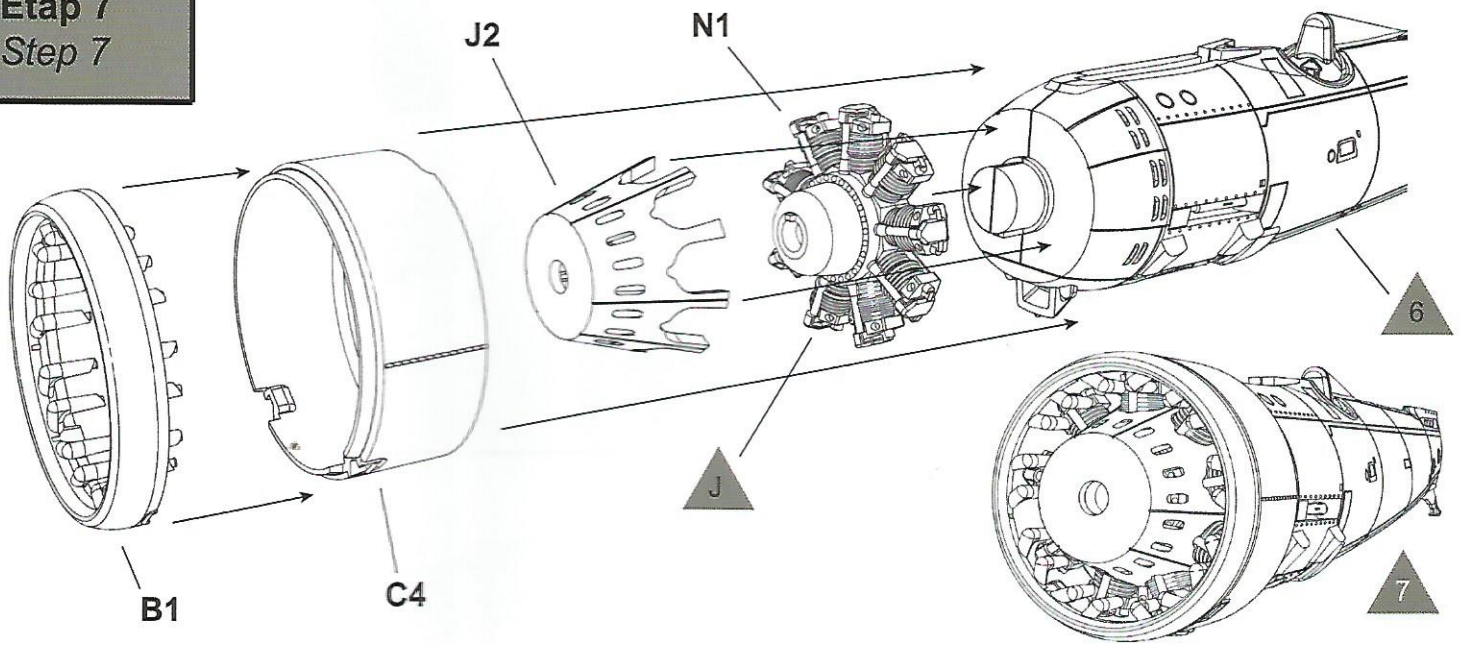

**Etap 8**  
Step 8

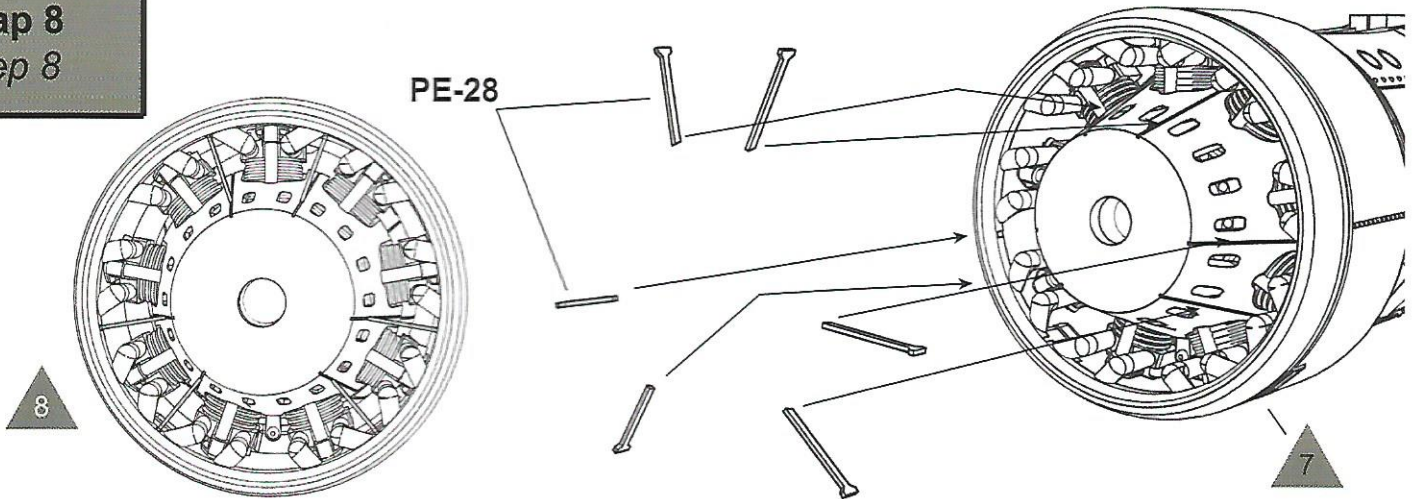

**Etap 9**  
Step 9

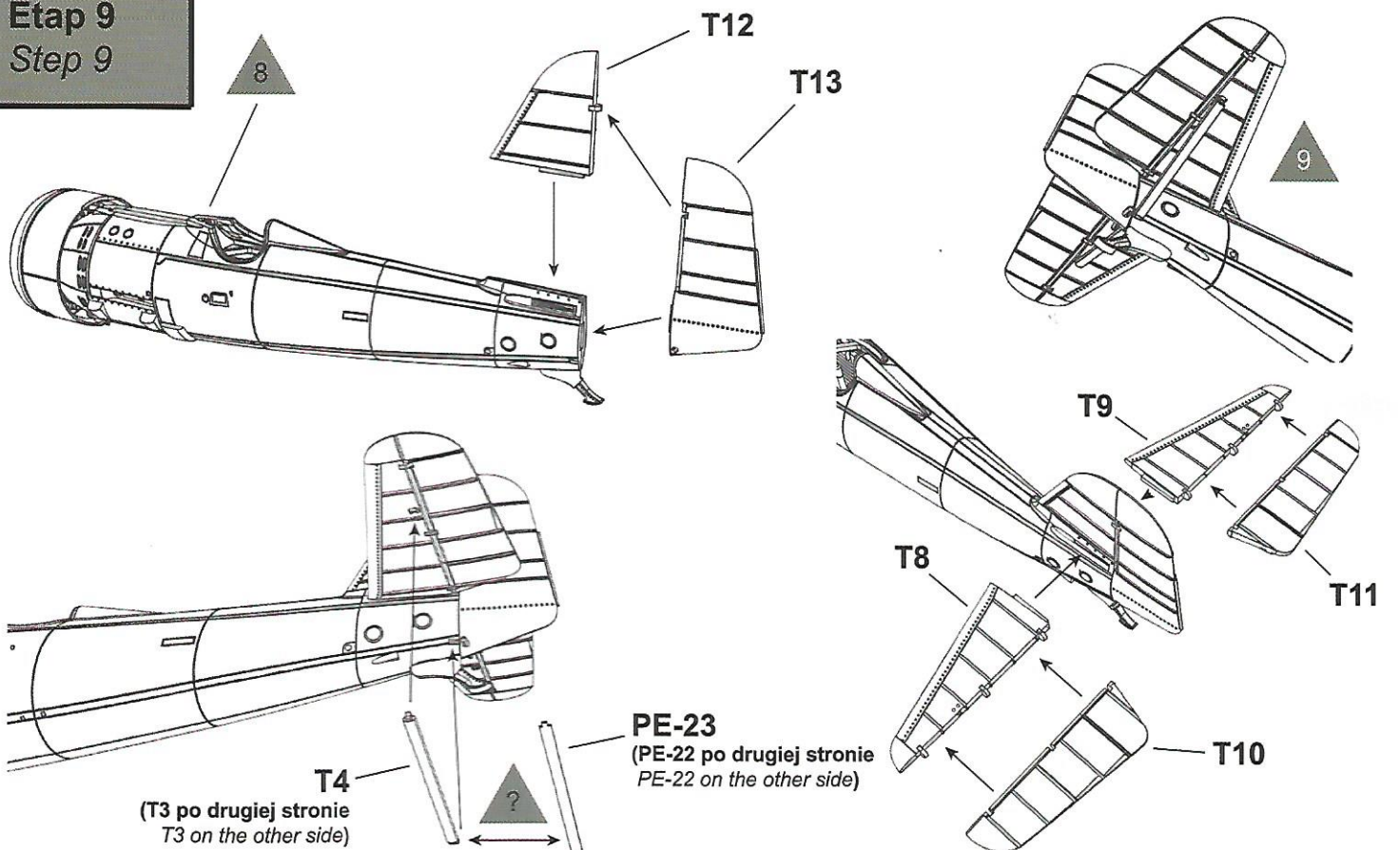

**Etap 10**  
*Step 10*

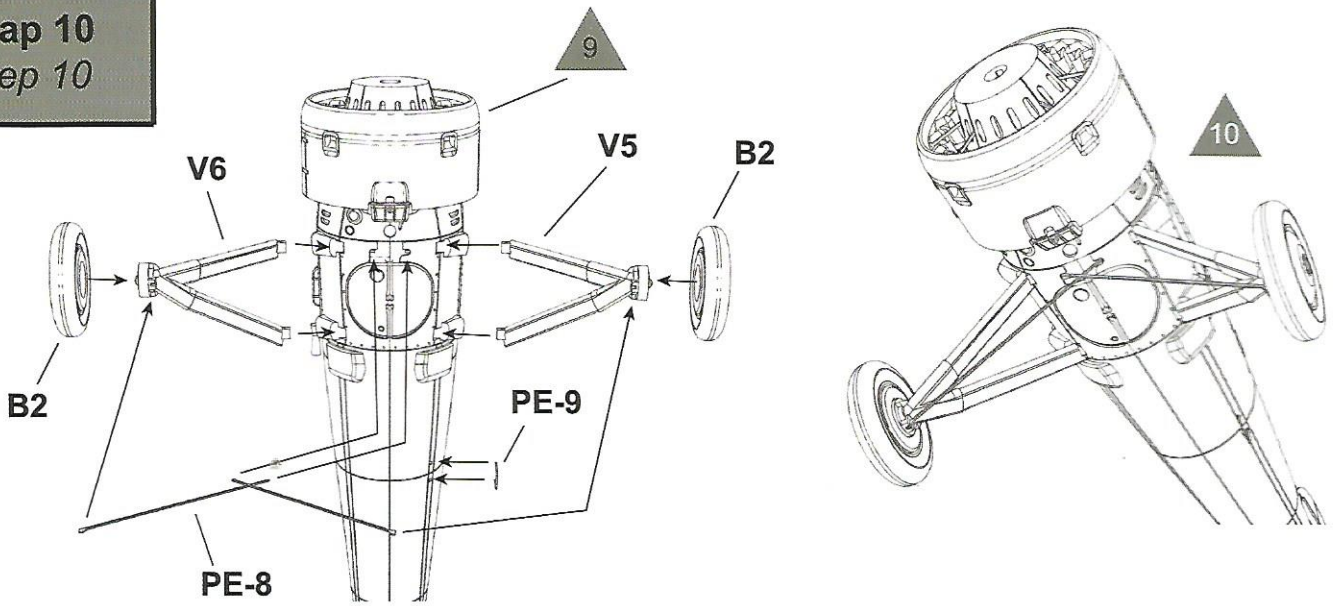

**Etap 11**  
*Step 11*

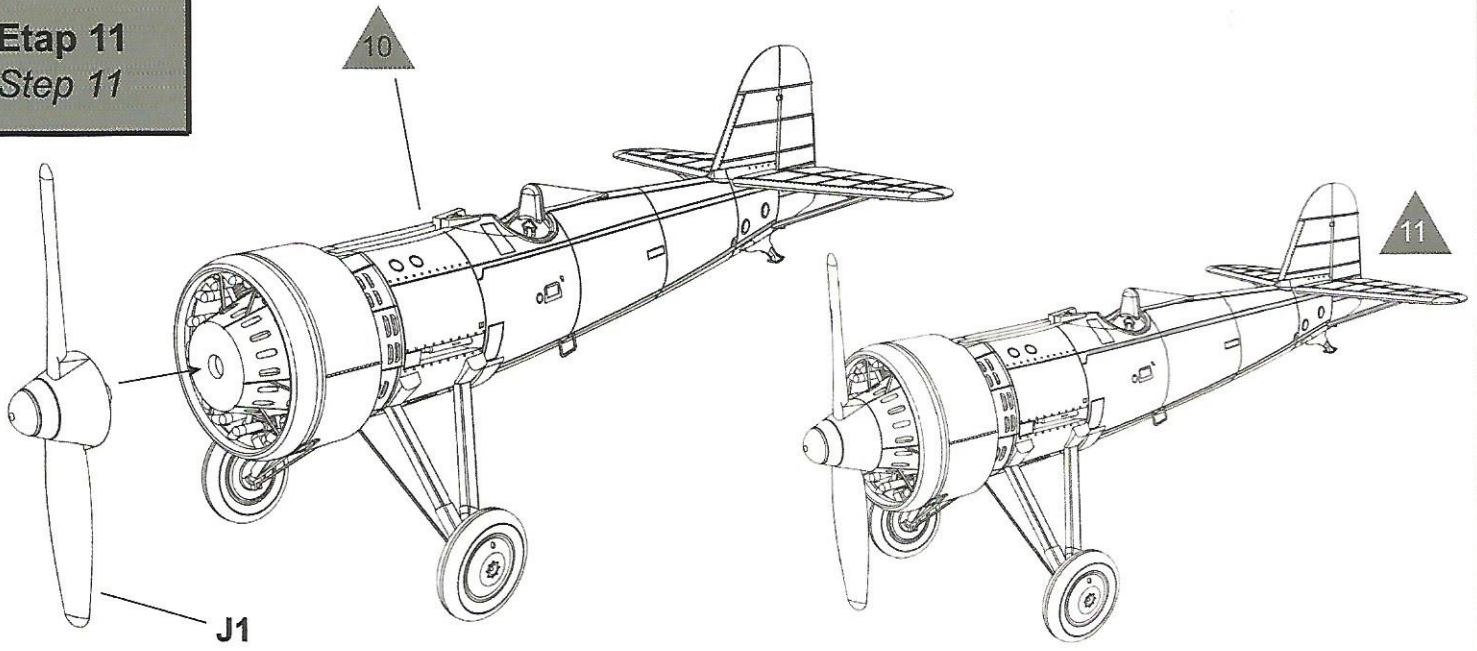

**Etap 12**  
*Step 12*

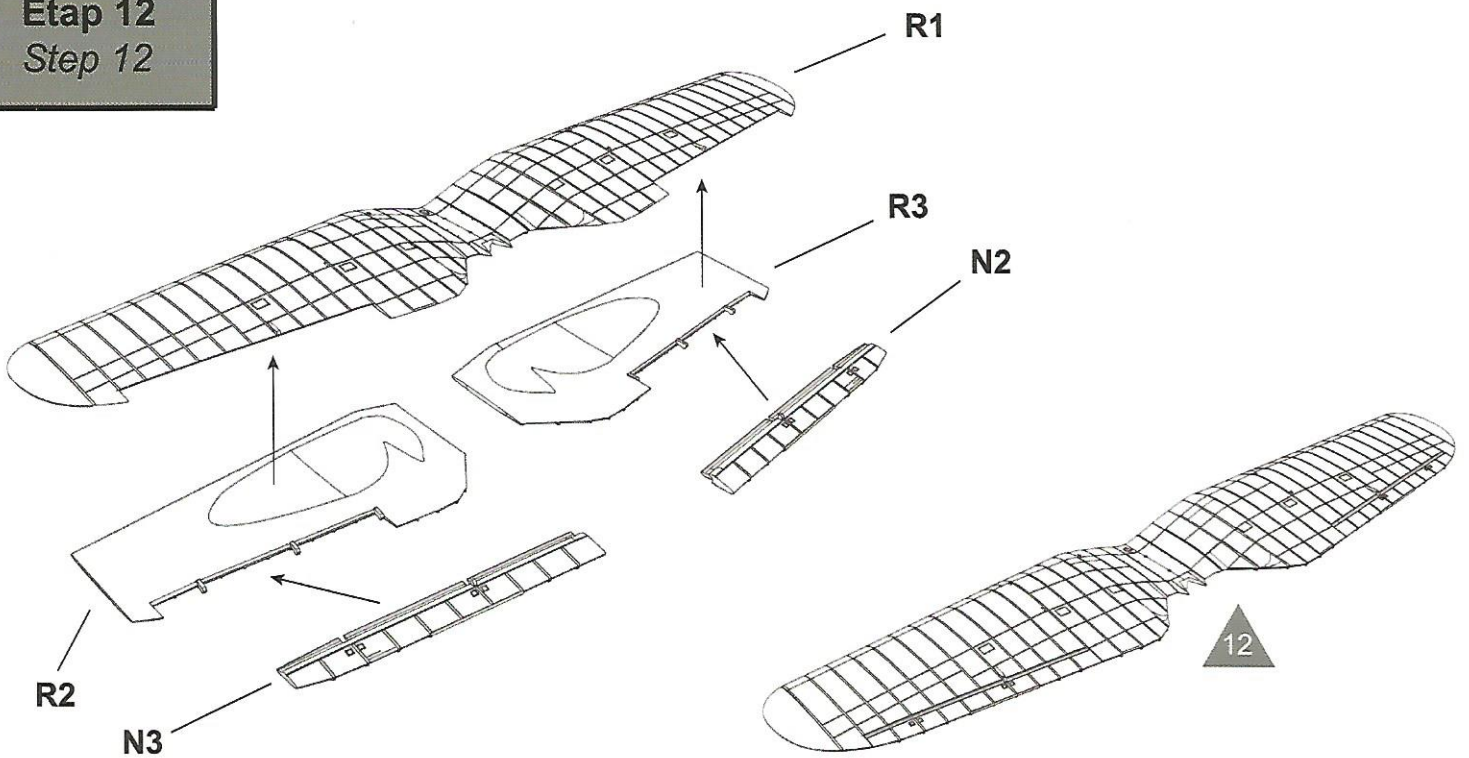

**Etap 13**  
**Step 13**

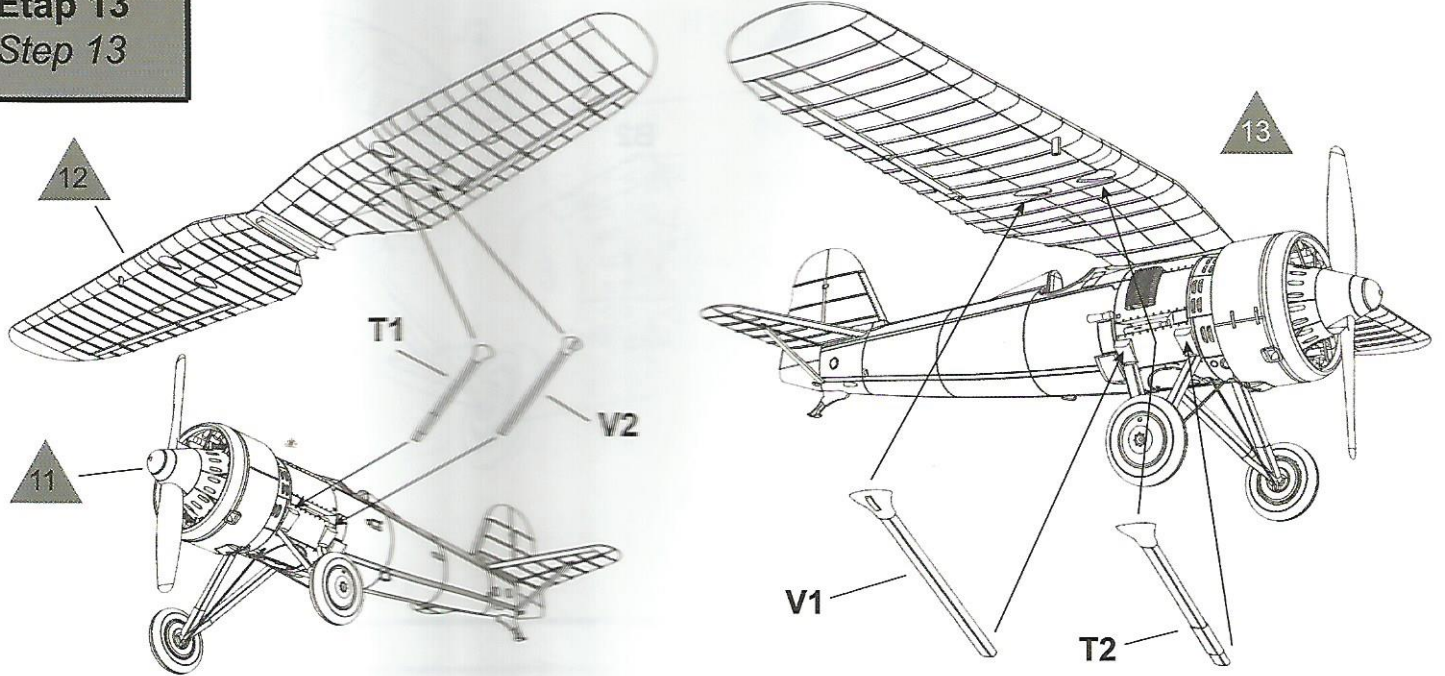

**Etap 14**  
**Step 14**

**Klisze wklejać od wewnętrznej strony części PE-33 /**  
*Glue the film from the inside of PE-33 part*

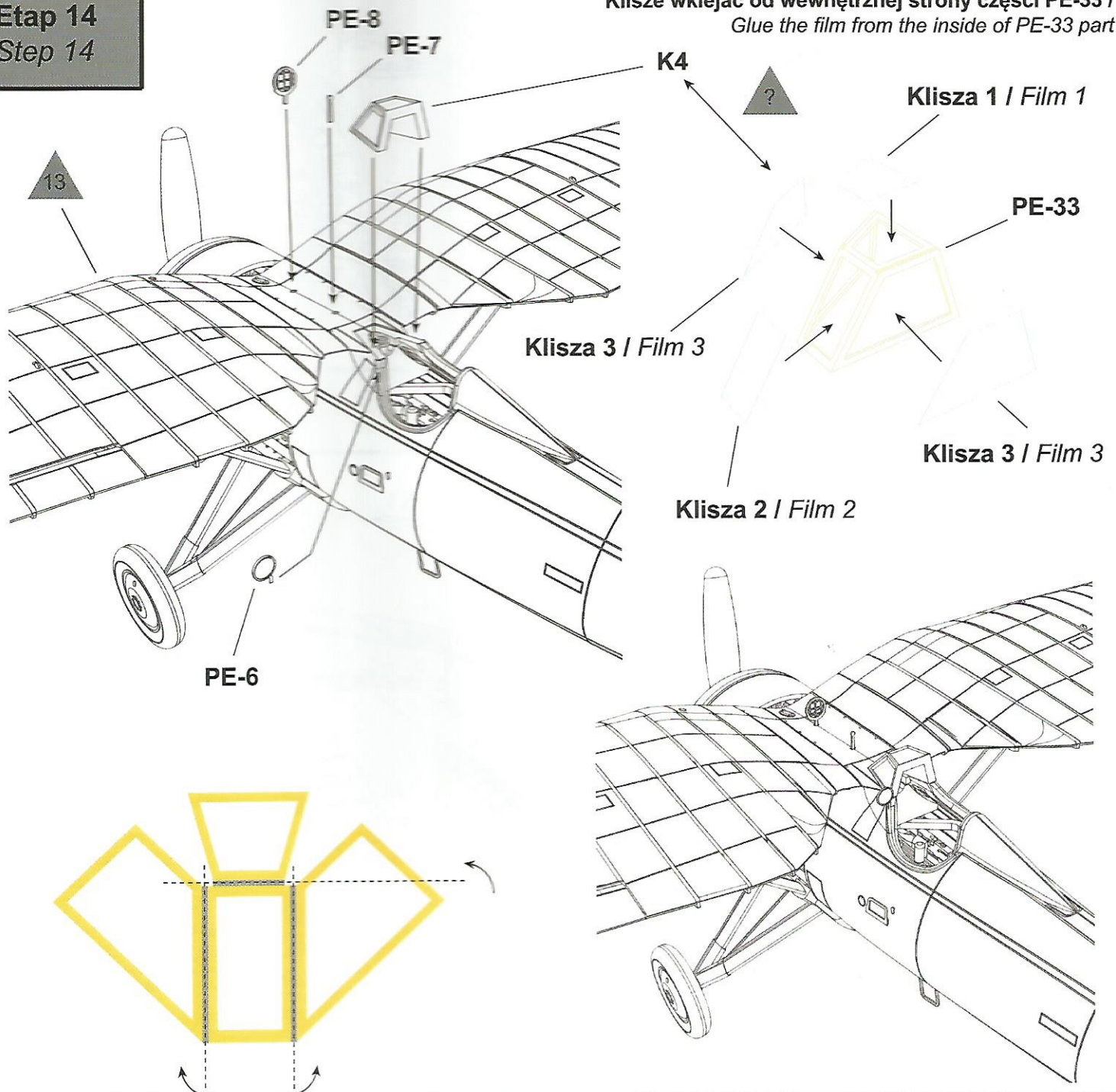

PZL P.11a, osobisty samolot mjr Józefa Kępińskiego, szefa szkolenia lotniczego w Centrum Wyszkolenia Lotnictwa nr 1, Dęblin, 1938-39 r. We wrześniu 1939 r. mjr Kępiński dowodził obroną powietrzną "Szkoły Orła" i uczestniczył w jej ewakuacji. Po przedostaniu się do Francji sformował i przeszkolił I/145 Dywizjon "Warszawski". 10 czerwca 1940r. został ciężko ranny w walce powietrznej. Za męstwo na polu walki odznaczony Srebrnym Krzyżem Virtuti Militari. Do latania bojowego już nie wrócił.

*PZL P.11a, personal airplane of S/Ldr Józef Kępiński, Head of Air Training in Air Training Centre no.1, Dęblin, 1938-39 In September 1939 S/Ldr Kępiński commanded air defence of the School of Eagles and participated in its evacuation. After reaching France through Romania, he organized and trained I/145 Fighter Squadron 'City of Warsaw'. On 10 June 1940 he was seriously wounded in air combat. For his merit he was awarded Silver Cross of Virtuti Militari War Order. He did not return to combat flying.*

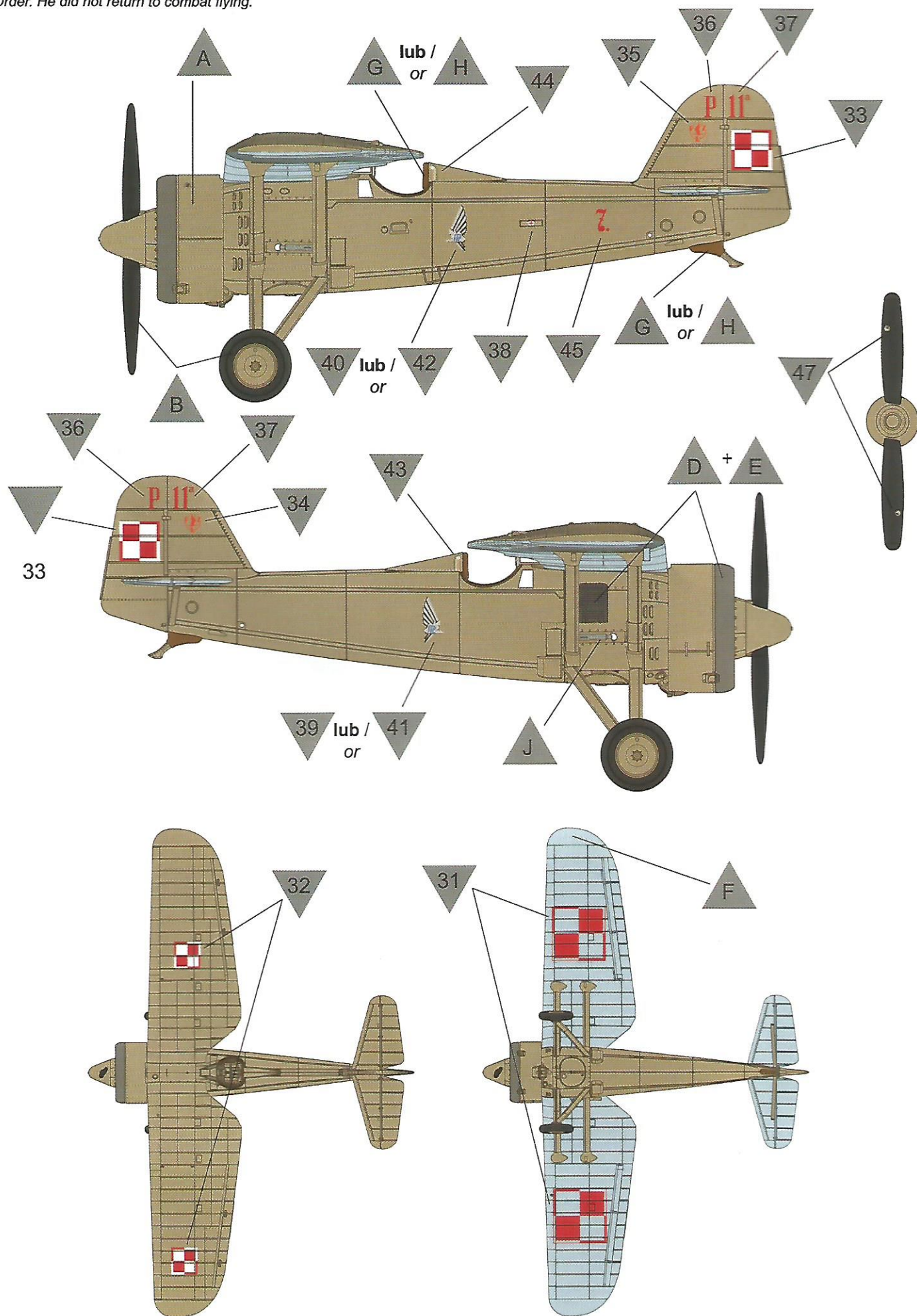

PZL P.11a, Dęblin, sierpień 1939

Na usterzeniu litera "T" namalowana w sposób charakterystyczny dla maszyn treningowych w 3 Pułku Lotniczym w Poznaniu

PZL P.11a, Dęblin, August 1939

Letter 'T' on the fin painted in a way typical for training machines of 3rd Air Regiment in Poznan

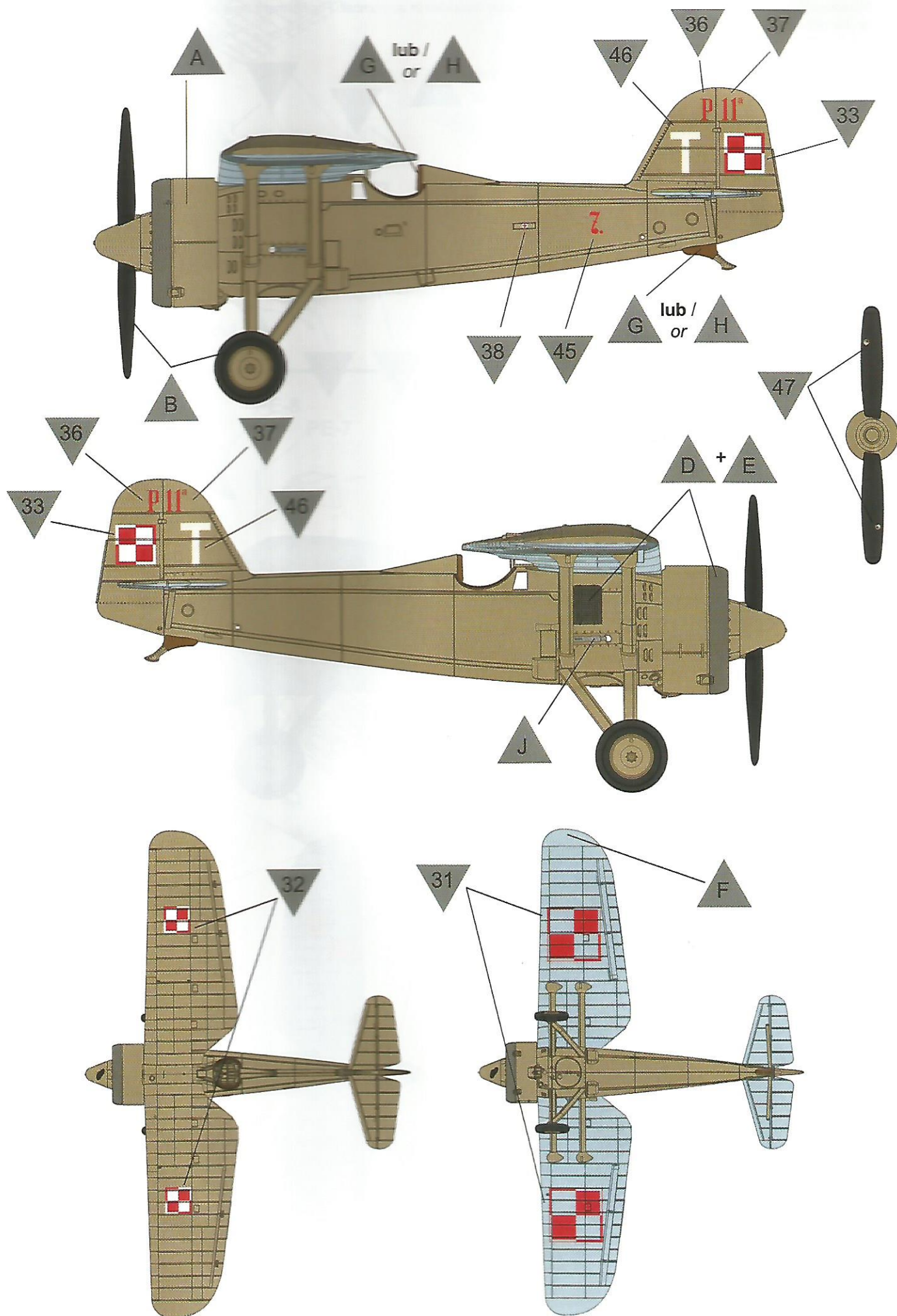

PZL.23A Karaś, nr 44.31, Centrum Wyszolenia Lotnictwa nr 1, Dęblin, ok. 1938 r.

Nie jest całkowicie pewne, czy numer seryjny 44.31 należał do tej konkretnej maszyny, czy też innego Karasia o numerze "2" w jednostce  
PZL.23A Karaś, no. 44.31, Air Training Centre no.1, Dęblin, around 1938

It is not entirely certain if the 44.31 serial number code belonged to this particular machine or other Karas number '2' in the unit

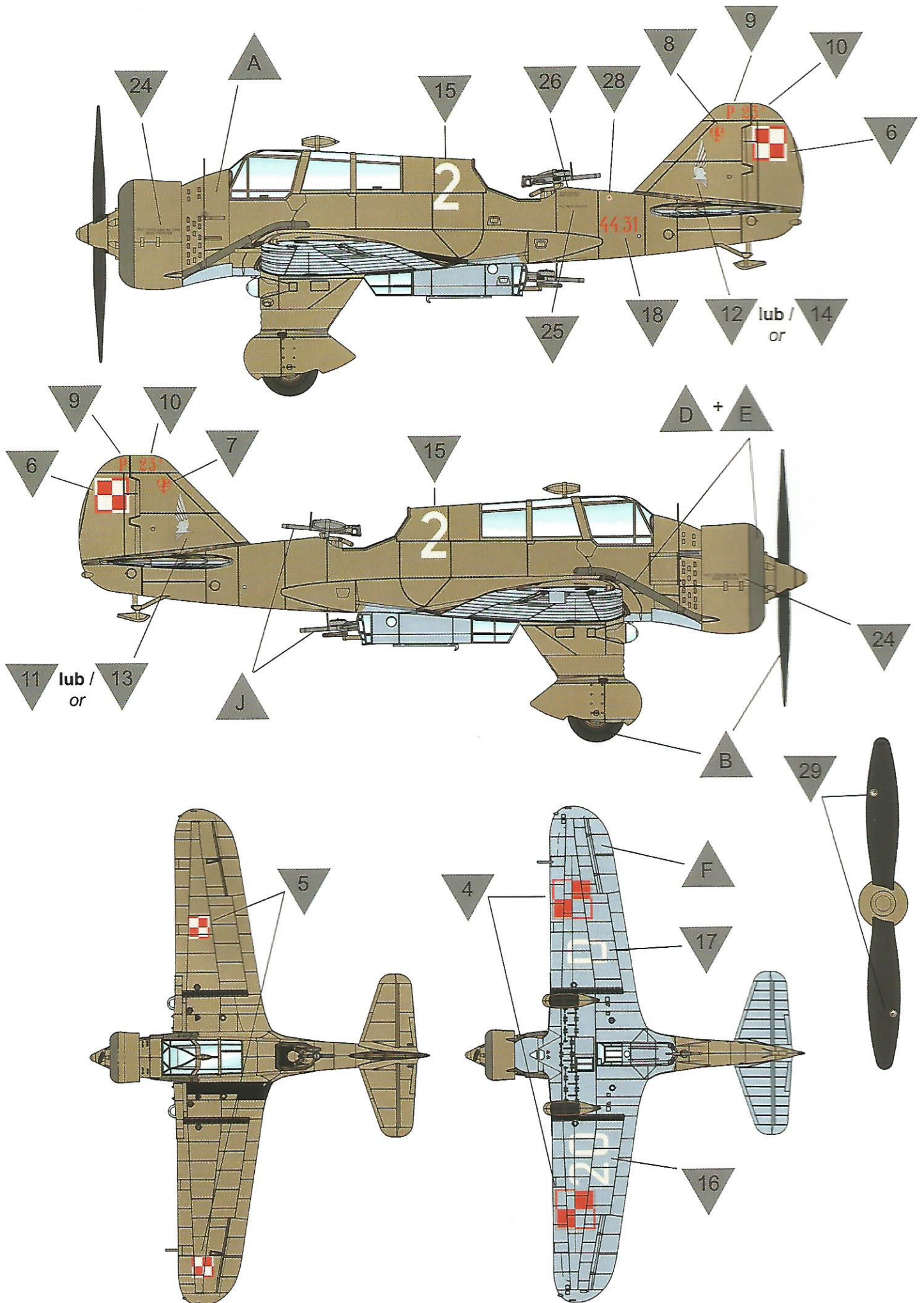

PZL.23A Karaś, Eskadra Treningowa 1. Pułku Lotniczego, Warszawa 1938 r.

Nie jest całkowicie pewne, czy numer podskrzydłowy 55-A należał do tej konkretnej maszyny, czy też innego Karasia w Eskadrze

PZL.23A Karaś, Training Flight of 1st Air Regiment, Warsaw 1938

It is not entirely certain if the 55-A underwing code belonged to this particular machine or other Karas in the Flight

