

# BOEING 747 *JUMBO JET*

1 / 100 IDENTICAL SCALE

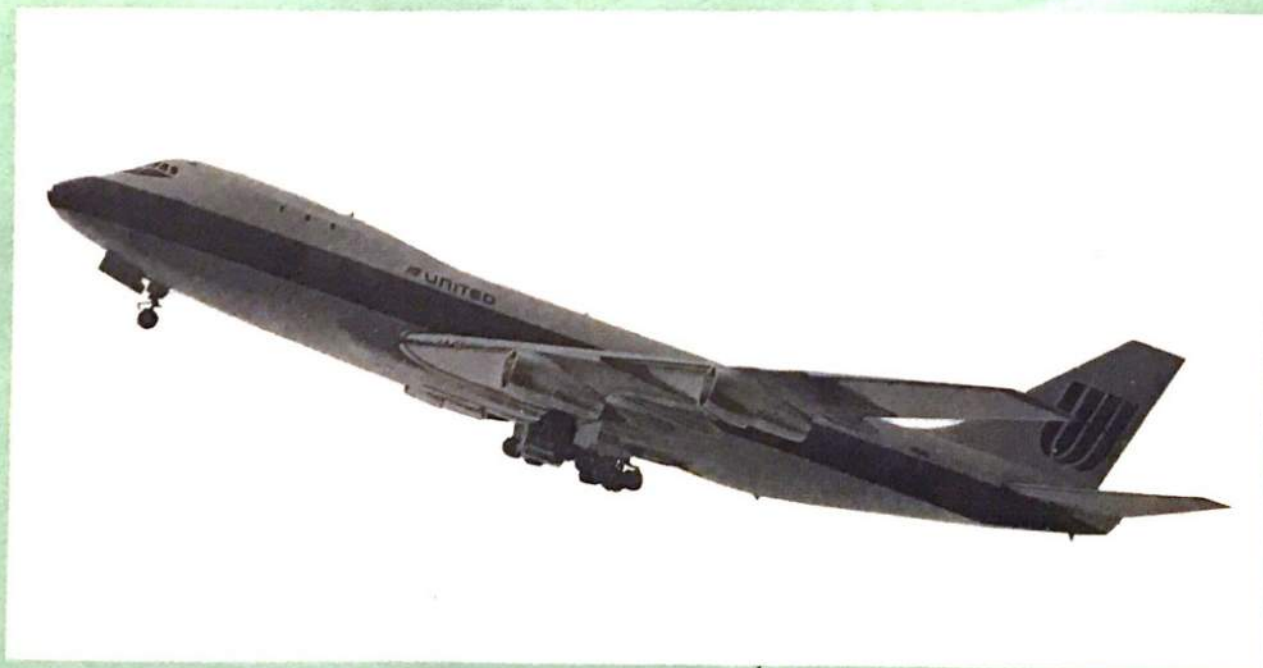

This kit can be built three ways:  
A Take Off. B Landing. C In Flight.  
Decide which to build before you start.  
Do not build undercarriages if C is selected.







## BOEING 747



Boeing began design and production of the biggest aeroplane ever to go into passenger service. This is the Boeing 747 which can carry up to 490 passengers although most are initially being equipped to carry about 360 passengers. In appearance the 747 resembles a scaled-up 707 but is a truly massive aeroplane, with the flight deck and first class lounge and bar on a separate deck above the main passenger cabins. The 747 has 50 ft greater span than the 707, is more than 78 ft longer, has more than twice the power and is well over double the weight.

The cabins of the 747 are 20 ft wide and the seating is arranged in three blocks with two aisles dividing the cabins lengthwise. The floor is more than 16 ft above the ground and the height to the top of the fin when the aircraft is at rest is more than 63 ft.

The thrust of each of the four Pratt & Whitney JT9D turbofans is 47,000 lb and the engine intakes have a diameter of 8 ft. The main undercarriage has sixteen wheels comprising four sets of four-wheel bogies. A cargo version with swing-nose can carry more than 100 tons.





Pan American operated the first 747 service, from New York to London, in January 1970, and more than 200 have been ordered by nearly thirty airlines including Air Canada, Air France, Air-India, Alitalia, American Airlines, BOAC, Japan Air Lines, KLM, Lufthansa, Qantas, SAS, South African Airways, Swissair, TWA and United Air Lines.

### KIT BUILDING TIPS FOR BEGINNERS

1. Trim all plastic parts from molding frame with sharp knife or nail clippers.
2. Smooth all sharp edges with sandpaper or nail file. Remove the coating on metalized parts where cement is to be applied.
3. Use "styrene" or "kit" glue (Testors and DuPont are good brands). Use a toothpick to apply and use sparingly so no excess is visible.
4. Hold small parts in place with tweezers, or brace them until they hold firm. Rubber bands and straight pins are helpful.
5. Be sure glue is firm in one joint before attempting the next.
6. Paint parts before assembly (if possible), using spray enamel, available at your local toy or hobby store. Several light coats, with drying time in between, are much better than one heavy coat.
7. Before gluing metal parts to plastic, use a coat of household glue on the metal for better bond.
8. All parts will fit. If not, you've made a mistake. Time and patience will insure good results. Adding weight (clay, metal washers, old small-size batteries) to hidden locations in a model makes it easier to handle (batteries can be placed in engines, under seats, or any place which will not be exposed when your model is complete).
9. Displaying your kit on a shelf, a board, or in a frame, will help protect it. Few kits survive a fall from a desk or table.

If you break or lose a part (and who doesn't once in a while?), all is not lost. Send 50¢ for handling, and a good description of the part needed, to:

**Helen Parts  
Entex Industries, Inc.  
1016 East Burgrove  
Carson, California 90746**

\*\$1.50 for fuselage 1 or 2.

#### WARRANTY (limited):

Entex guarantees its products against defects due to faulty workmanship and materials for 90 days from the date of purchase. Send the defective part or description of missing parts to the address shown on this sheet. Be sure to include your name and address.

AREAS TO APPLY CEMENT ARE PRINTED GREEN.

Paint colors shown are optional.



Parts List

A

A<sup>28</sup> have no use for construction.

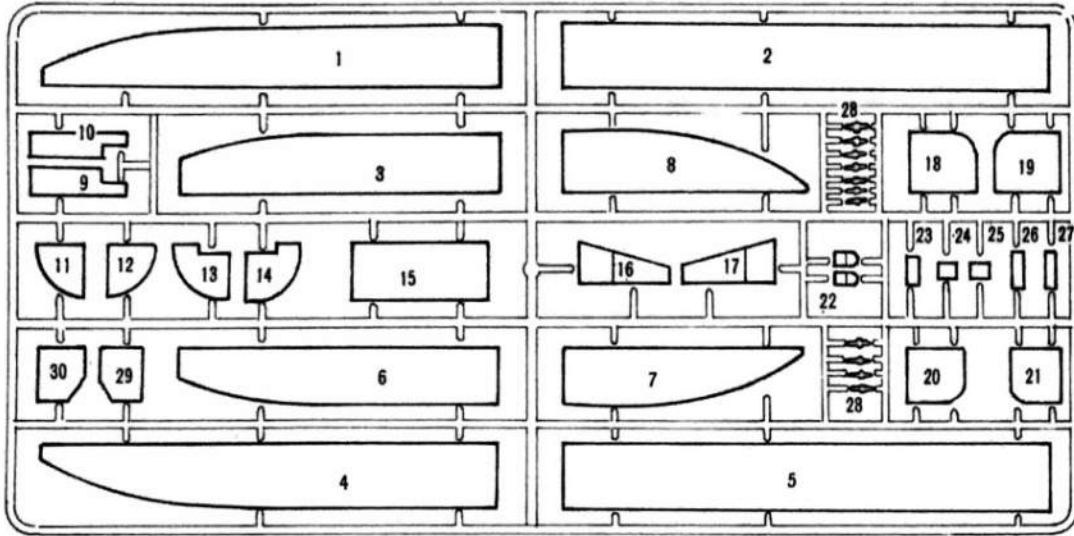

B

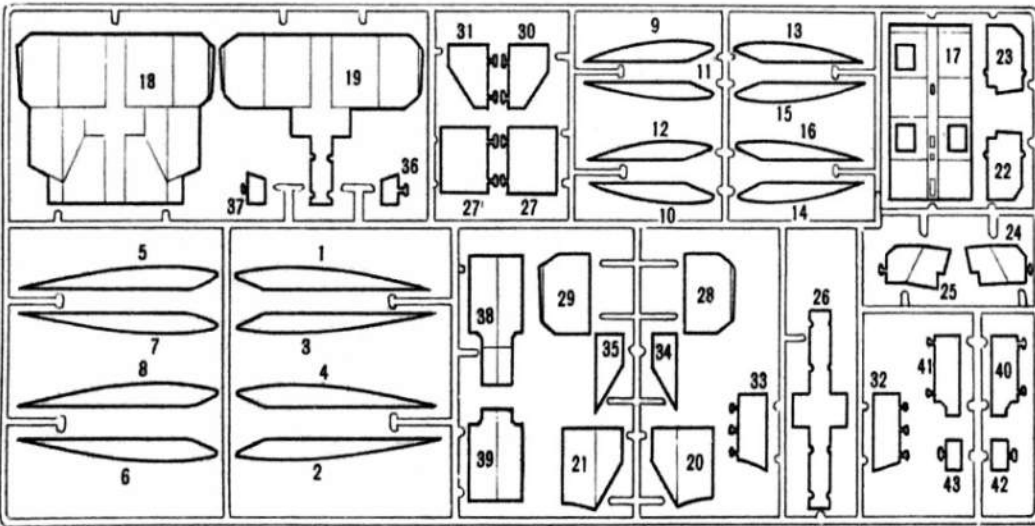

- 1. deck
- 2. deck
- 3. deck
- 4. deck
- 5. deck
- 6. deck
- 7. flight deck
- 8. flight deck
- 9. nose gear
- 10. nose gear
- 11. flight deck part
- 12. flight deck part
- 13. flight deck part
- 14. flight deck part
- 15. landing gear
- 16. nose gear
- 17. nose gear
- 18. landing gear
- 19. landing gear
- 20. landing gear
- 21. landing gear
- 22. body landing gear part
- 23. door
- 24. nose gear
- 25. nose gear
- 26. nose gear
- 27. nose gear
- 28. door part

- 1. flap track fairing access (No.1)
- 2. flap track fairing access (No.1)
- 3. flap track fairing access (No.1)
- 4. flap track fairing access (No.1)
- 5. flap track fairing access (No.2)
- 6. flap track fairing access (No.2)
- 7. flap track fairing access (No.2)
- 8. flap track fairing access (No.2)
- 9. flap track fairing access (No.3)
- 10. flap track fairing access (No.3)
- 11. flap track fairing access (No.3)
- 12. flap track fairing access (No.3)
- 13. flap track fairing access (No.4)
- 14. flap track fairing access (No.4)
- 15. flap track fairing access (No.4)
- 16. flap track fairing access (No.4)
- 17. fuselage part
- 18. landing gear door (closed)
- 19. landing gear door (closed)
- 20. body landing gear door (closed)
- 21. body landing gear door (closed)
- 22. wing gear door (closed)
- 23. wing gear door (closed)
- 24. wing gear door (open)
- 25. wing gear door (open)
- 26. door part
- 27. wing gear door
- 28. wing gear door
- 29. wing gear door
- 30. body gear door
- 31. body gear door
- 32. body gear door
- 33. body gear door
- 34. body gear door
- 35. body gear door
- 36. body gear door
- 37. body gear door
- 38. nose door
- 39. nose door
- 40. nose door
- 41. nose door
- 42. nose door
- 43. nose door

C

Two C 1 is spare parts.

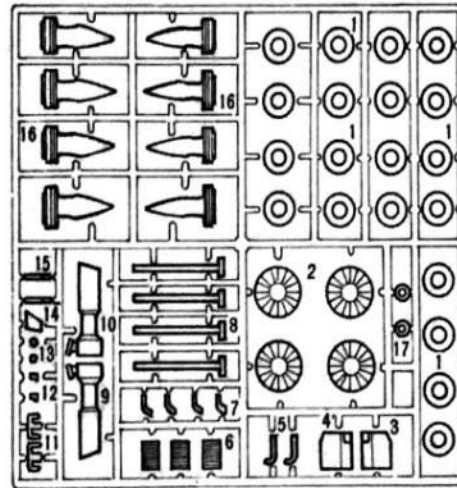

TWO C 13 and four C 9 are spare parts  
C 25 are not used.

D

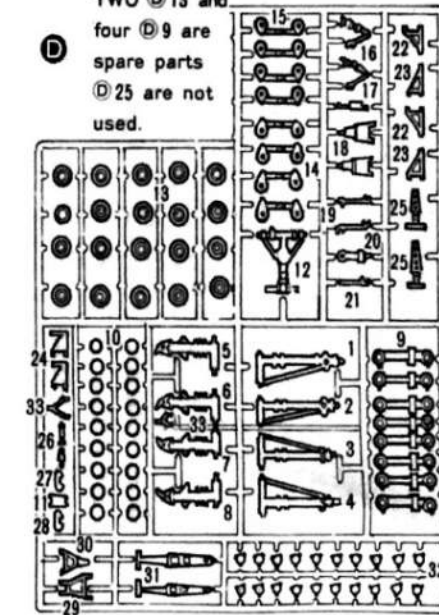

- 1. wheel tyres
- 2. engine fan
- 3. meter
- 4. meter
- 5. control stick part
- 6. ventilator
- 7. antenna
- 8. shaft
- 9. power unit
- 10. power unit
- 11. control stick
- 12. antenna
- 13. antenna
- 14. antenna
- 15. engine
- 16. engine
- 17. engine

- 1. wing landing gear
- 2. wing landing gear
- 3. wing landing gear
- 4. wing landing gear
- 5. body landing gear
- 6. body landing gear
- 7. body landing gear
- 8. body landing gear
- 9. landing gear part
- 10. landing gear part
- 11. nose landing gear part
- 12. nose landing gear part
- 13. wheel hub
- 14. brake lock
- 15. brake lock
- 16. wing landing gear part
- 17. nose landing gear part

- 18. wing landing gear part
- 19. body landing gear part
- 20. nose landing gear part
- 21. nose landing gear part
- 22. wing landing gear part
- 23. wing landing gear part
- 24. body landing gear part
- 25. body landing gear part
- 26. nose landing gear part
- 27. nose landing gear part
- 28. nose landing gear part
- 29. nose landing gear part
- 30. nose landing gear part
- 31. wing landing gear part
- 32. stopper
- 33. body landing gear part

E

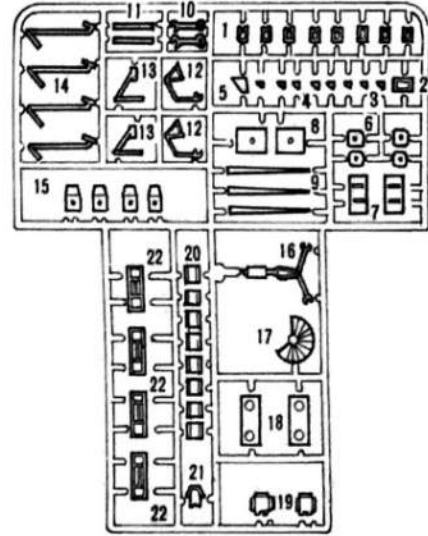

F

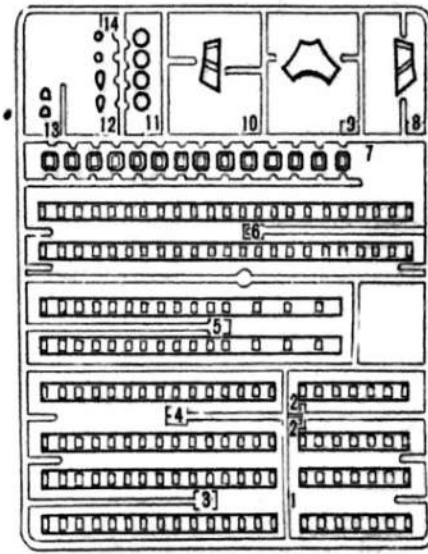

- 1. Seat part
- 2. box
- 3. door part
- 4. door part
- 5. antenna
- 6. seat part
- 7. seat
- 8. table
- 9. antenna
- 10. door rod
- 11. rod
- 12. door rod
- 13. door rod
- 14. door rod
- 15. seat
- 16. bell crank
- 17. stair
- 18. seat
- 19. seat
- 20. chock
- 21. nose landing gear part
- 22. chock

- 1. window
- 2. window
- 3. window
- 4. window
- 5. window
- 6. window
- 7. window
- 8. canopy
- 9. canopy
- 10. canopy
- 11. landing light
- 12. light (wing)
- 13. light
- 14. landing light

# Parts List

2 fuselage (right)  
1 fuselage (left)

wing (upper)

tailplane (upper)

wing (lower)

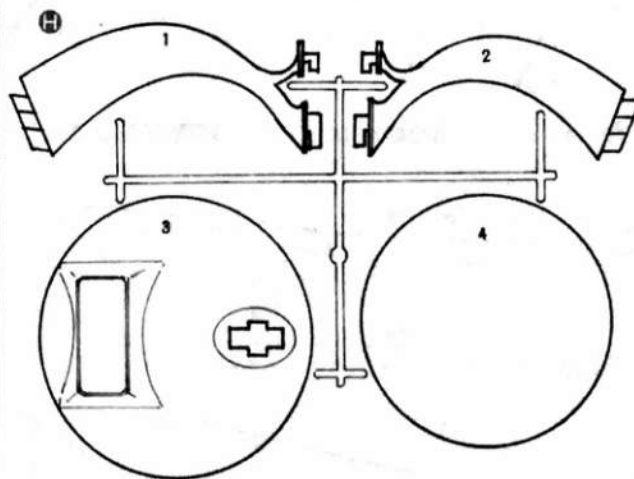
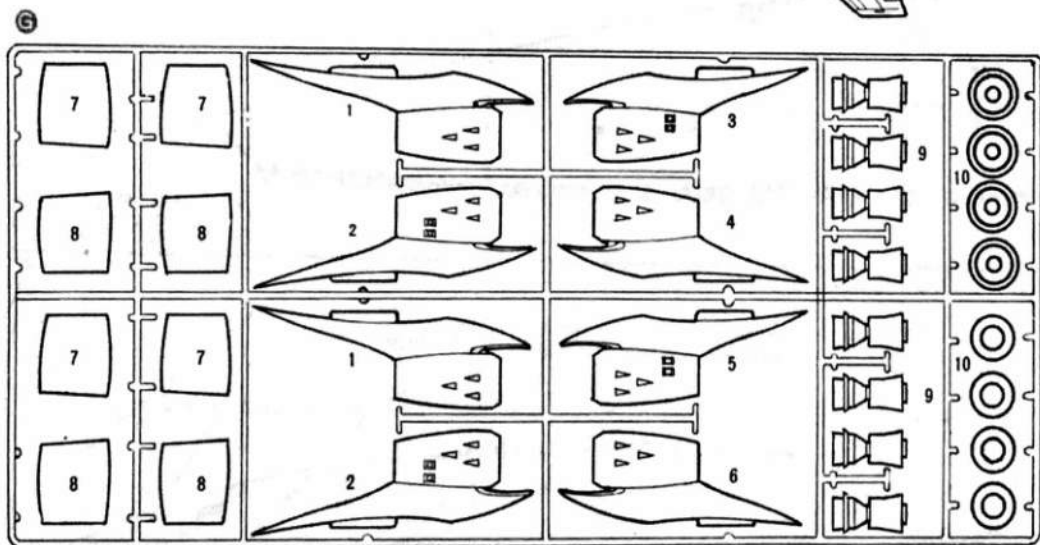
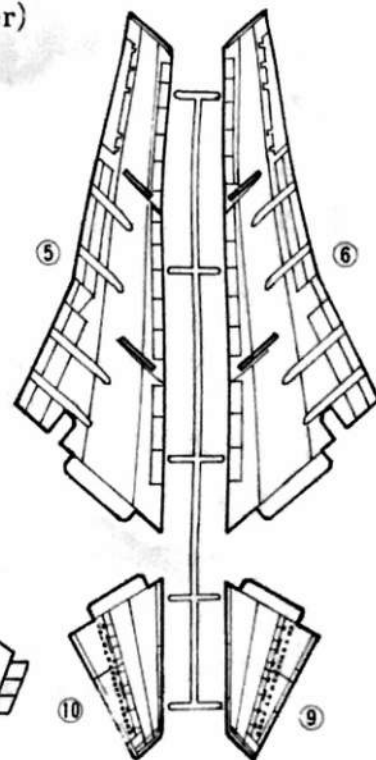
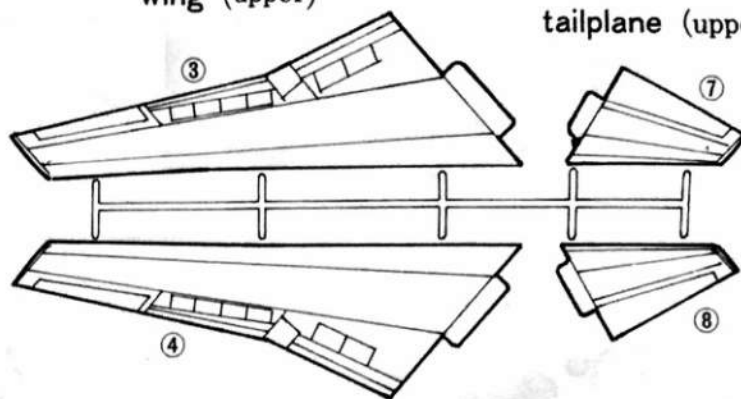
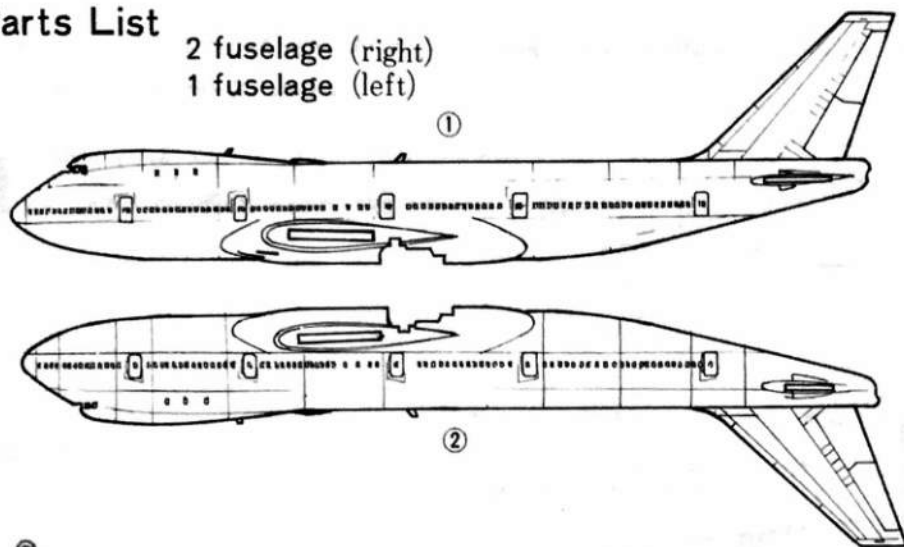

tailplane (lower)

- |                |                    |            |         |
|----------------|--------------------|------------|---------|
| 1. engine pods | 6. engine pods     | 1. support | 3. base |
| 2. engine pods | 7. engine nacelles | 2. support | 4. base |
| 3. engine pods | 8. engine nacelles |            |         |
| 4. engine pods | 9. engine parts    |            |         |
| 5. engine pods | 10. engine parts   |            |         |

## Important

Some of the detail on this model kit is very fine. For the inexperienced model builder, some of the steps can be eliminated. These are noted in the instructions.

For best results, use tweezers to place small parts and be sure to trim off the surplus plastic, which will be found at the point at which the part is cut from the frame.





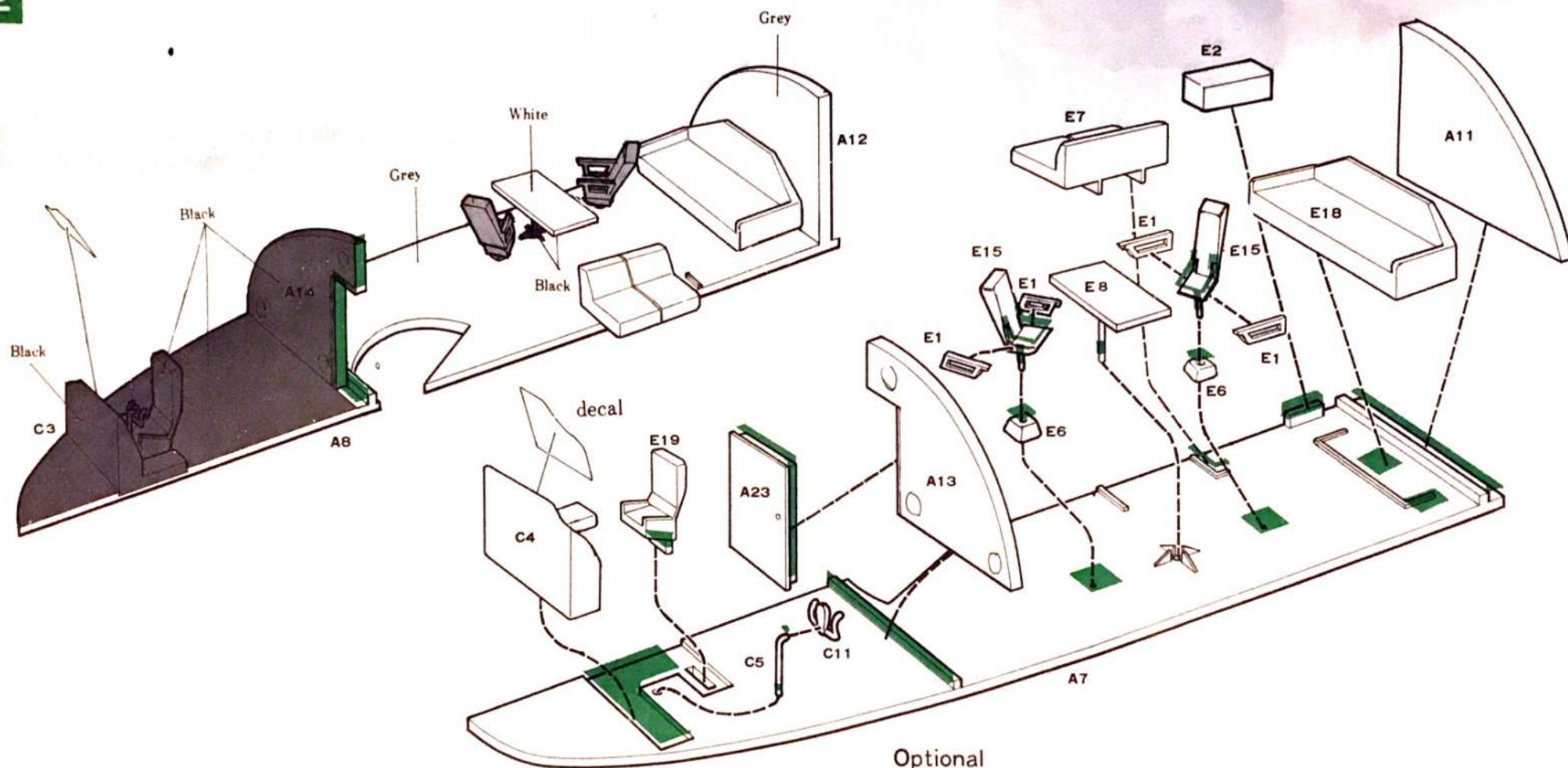

**2****Optional**

Assembling the lounge and decks (see Step 6) into the fuselage requires care and skill. For ease of construction, these may be eliminated.

**2**

Cement all parts together as shown, and to A ⑦ and A ⑧.

Make sure that the long edges of bulkheads A 11 and A 12 are cemented to the decks A ⑦ and A ⑧. Door A 23 must fit easily into A 14 or be left in the open position.

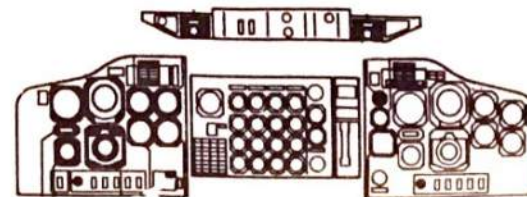
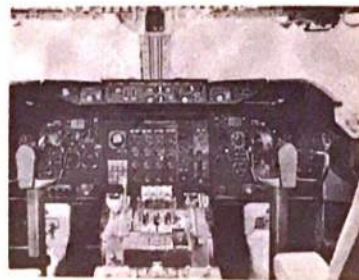

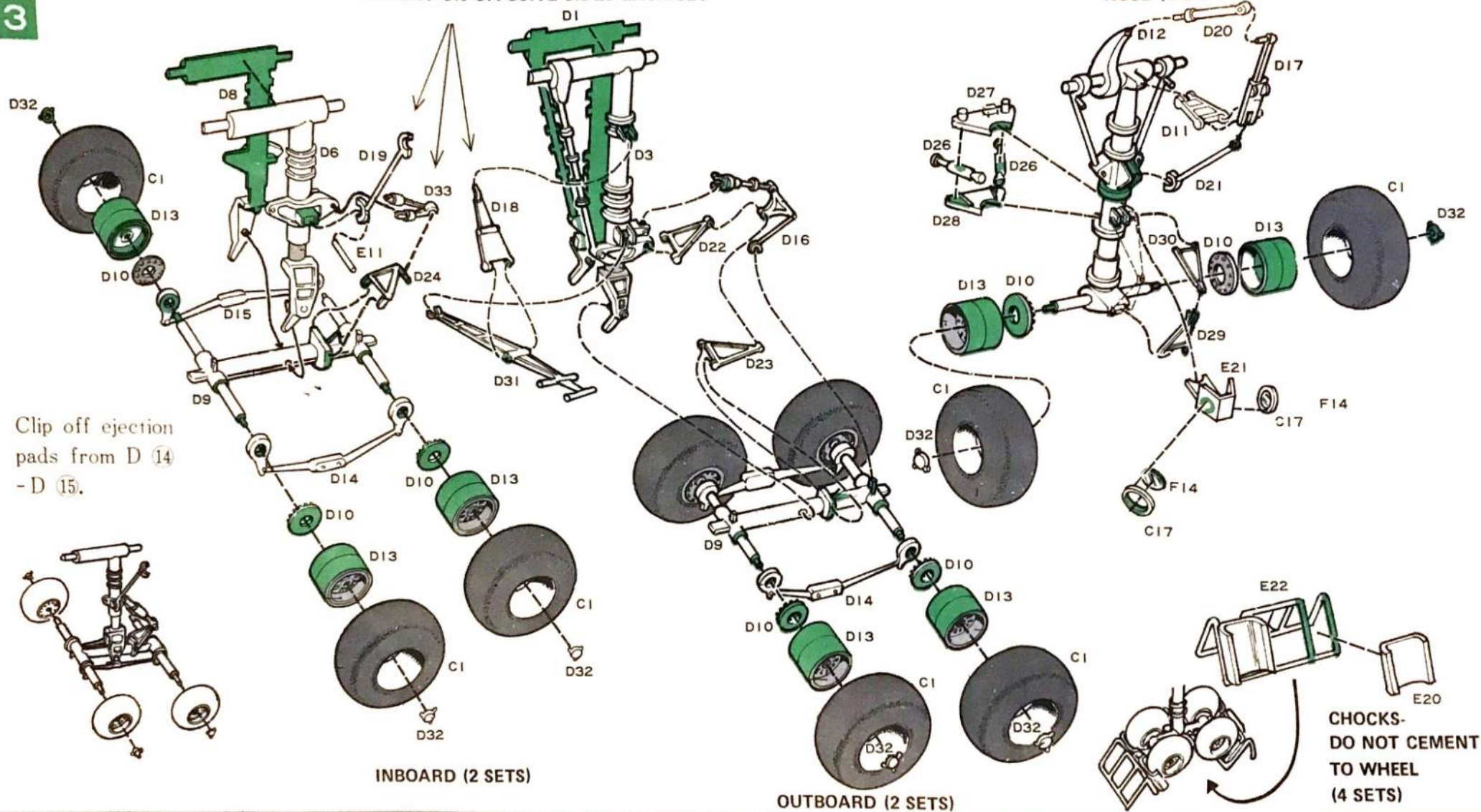

**3****CEMENT ON OPPOSITE SIDES EACH SET****NOSE (1 SET)**

Clip off ejection pads from D 14 - D 15.

CHOCKS-DO NOT CEMENT TO WHEEL (4 SETS)

**3**

(Not required for In Flight construction) Make up landing gear as shown. Important: D 19, D 18, and D 31 should not be cemented on until steps 5 - 6, as they are cemented on opposite sides to make righthand and lefthand sets.

D 32 is only required if you want the wheels to rotate.

Use tweezers to position.

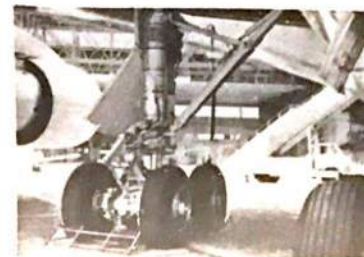
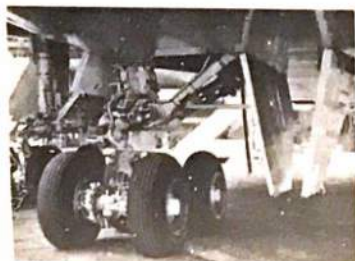



4

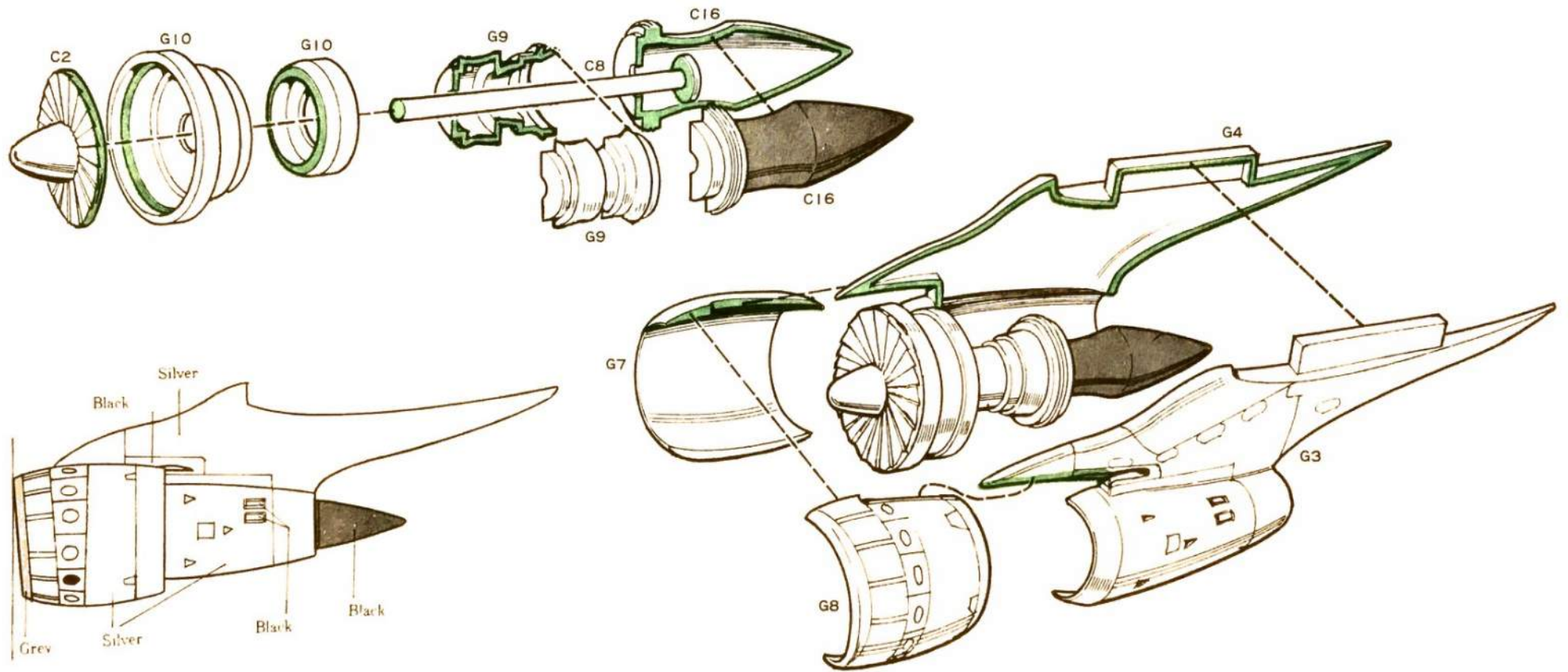

4 Make up 4 engines as shown, using engine pods G ① through G ⑥.

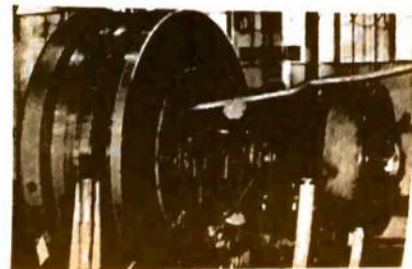
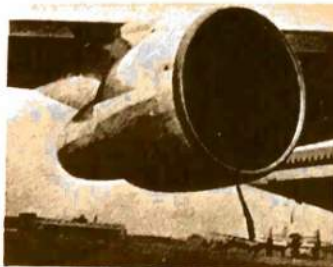



5

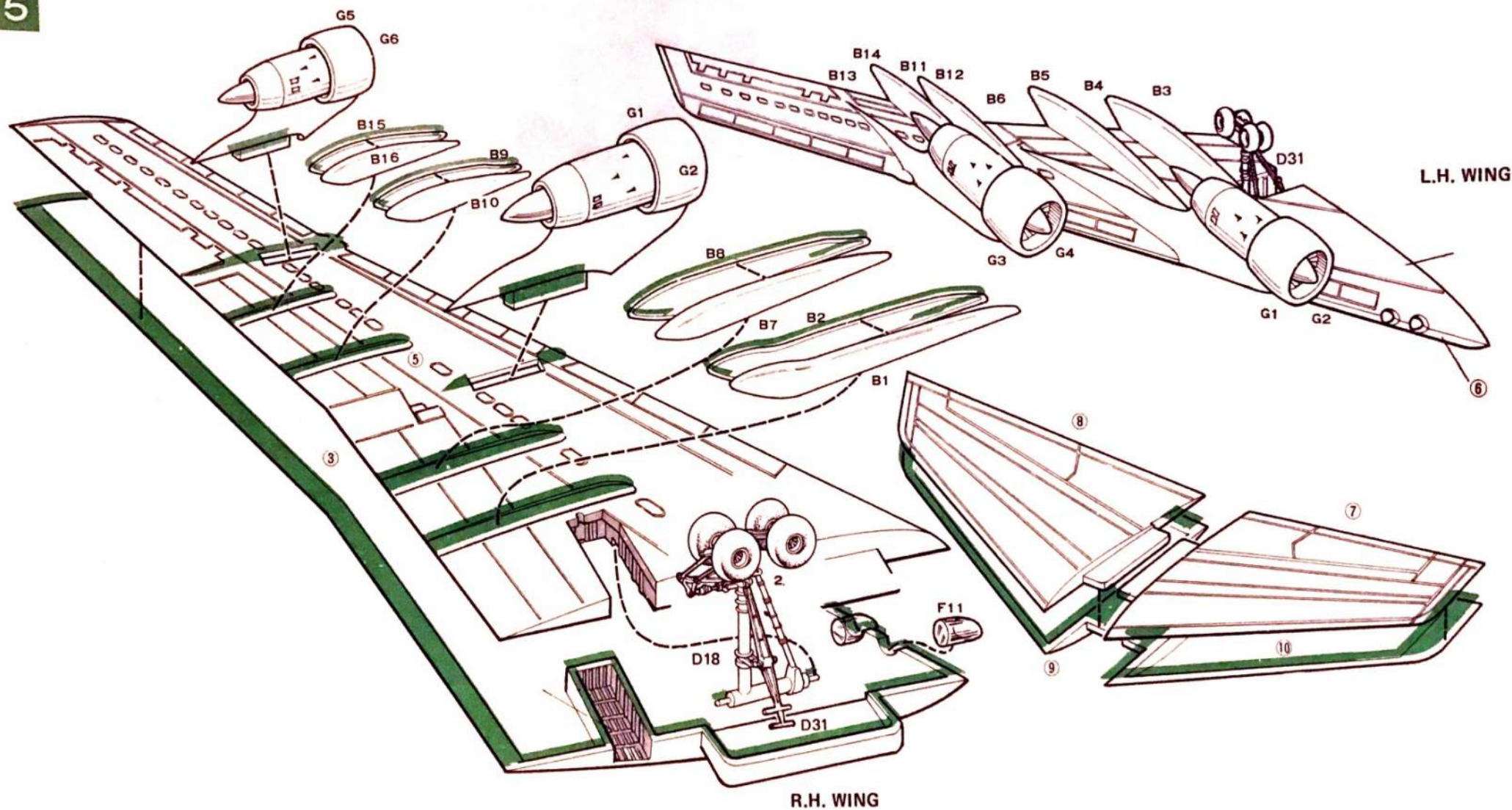

5

Cement outboard landing gear to lower wing halves. Make up lefthand and righthand wings and tails as shown.





6

Important-OPTIONAL

For simple assembly, the following parts can be eliminated:  
A 3 6 14 7 8, E 17.

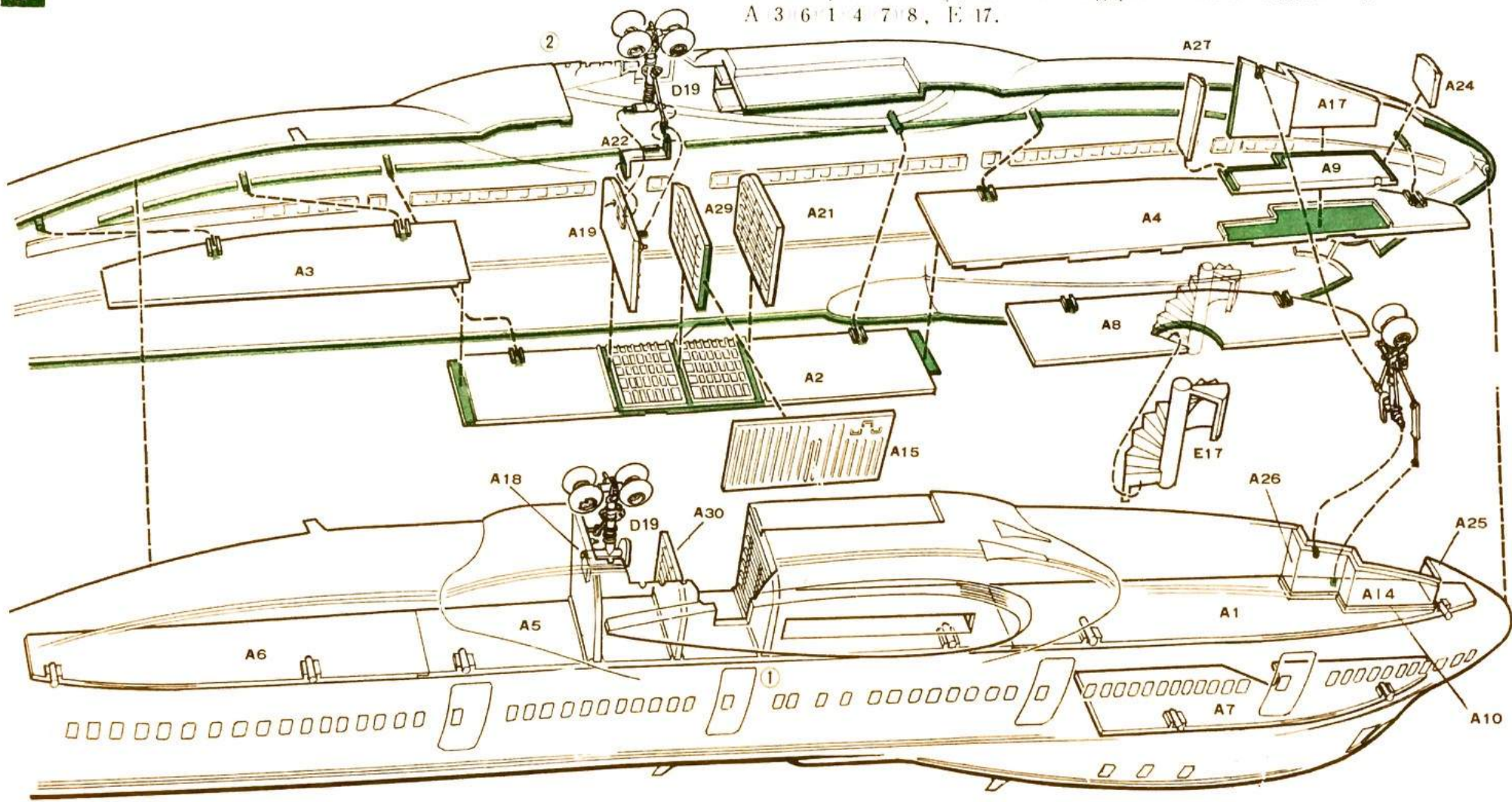

6

Cement all parts in place in each half of the fuselage. Cement A 22 over the inboard undercarriages and to A 19 on each side. Cement D 19 in place.

Cement fuselage halves 1 and 2 together with care. Hold with string or rubber bands until dry.

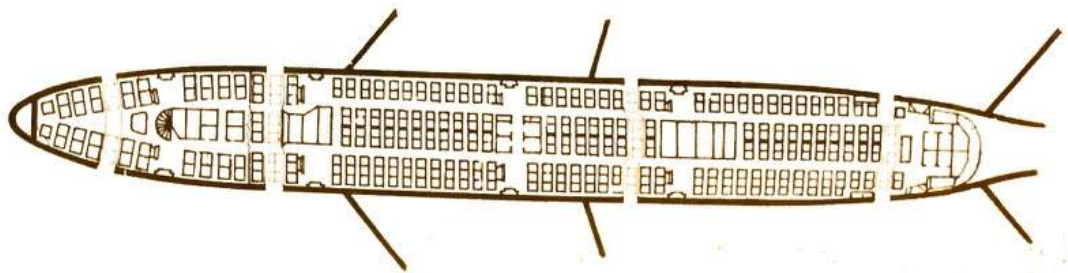



7

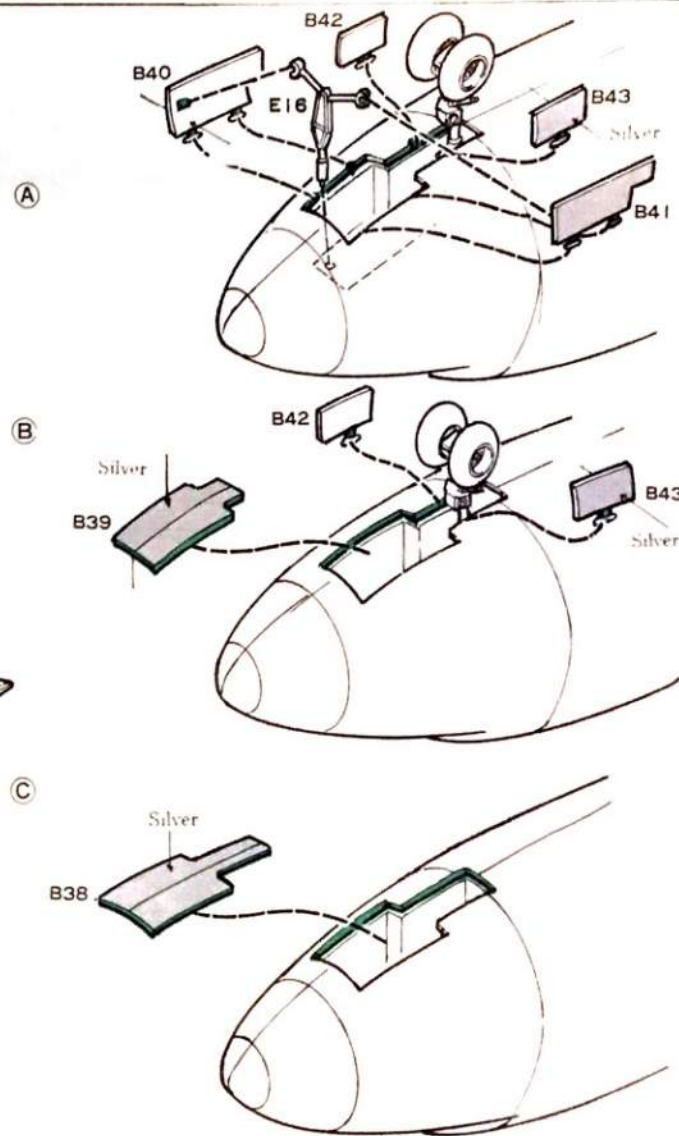
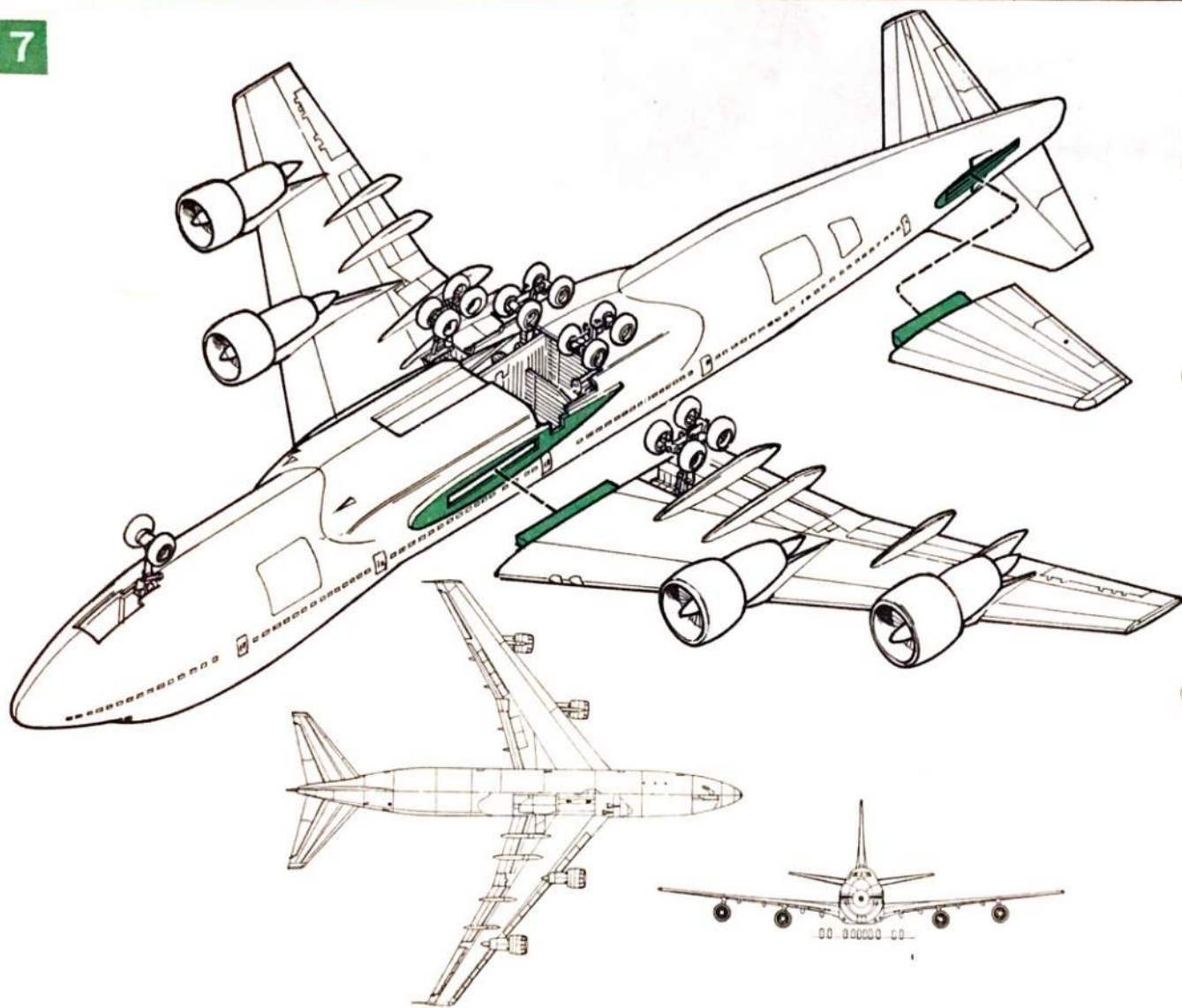

7

Cement wings and tail section to the fuselage. Diagrams A - B - C show optional positions for the nose undercarriage.





**8**

Assemble underside according to method selected A, B or C.

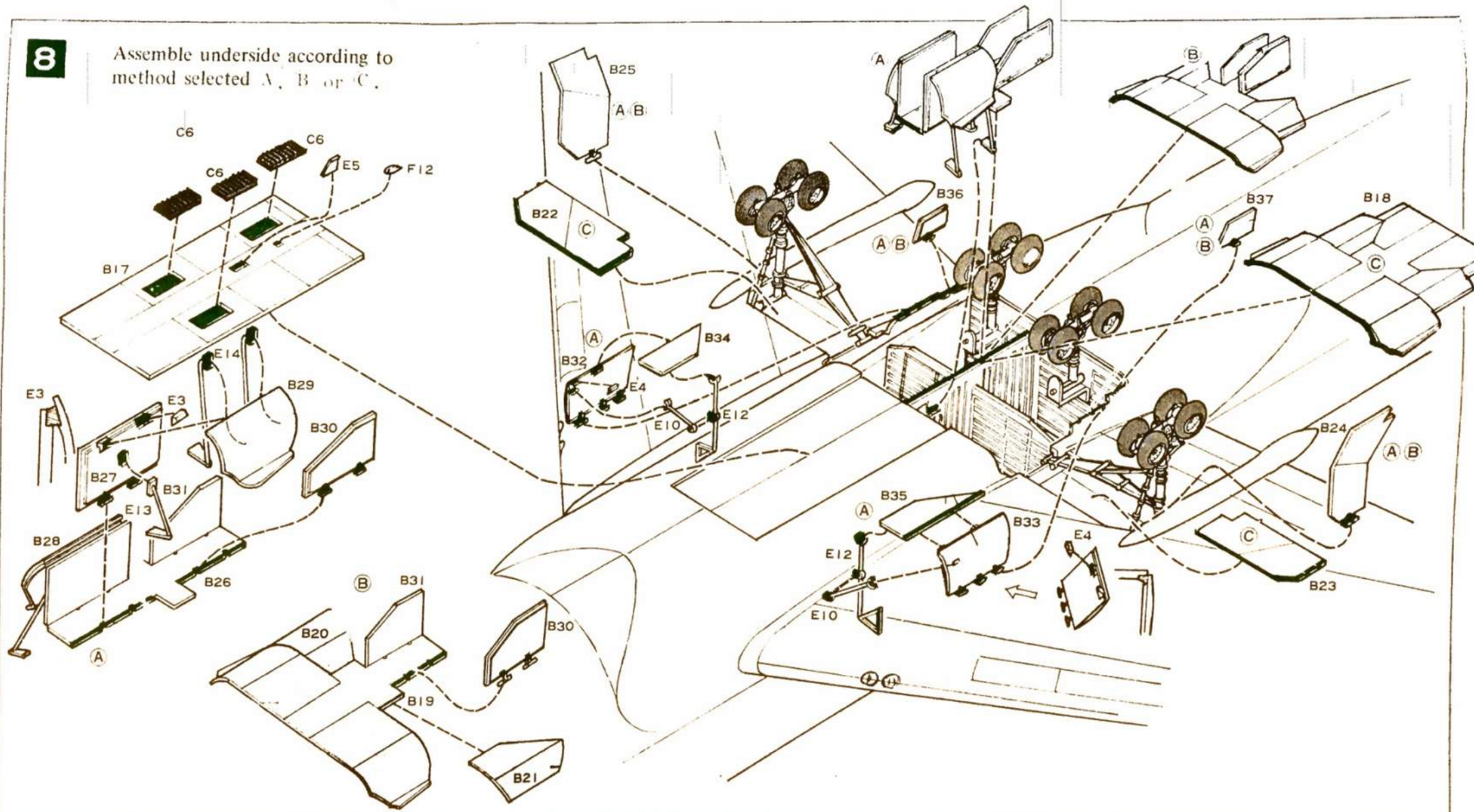
**8**

As shown in figure, cement C 6 E 5 F 12 to the hole of B 17 and then cement B 17 as per figure.

A As shown in figure, cement E 3 and E 13 to B 27 E 14 to B 29 and then cement B 27-29 as per figure.

A As shown in figure, cement B 30 31 27 28 to B 26 and then cement doors assembled to fuselage.

A As shown in figure, cement B 35 37 24 25 and then cement E 4 to B 33, and E 12 to B 35 as per figure.

B A As shown in figure, insert and cement B 20 21 30 31 to B 19 and then cement it to fuselage.

C A As shown in figure, insert and cement of B 18 22 23 to fuselage.

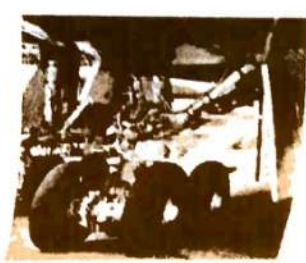
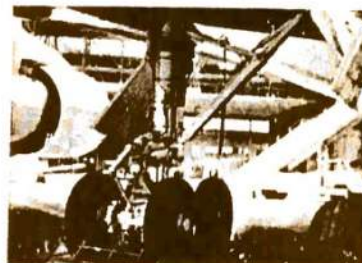
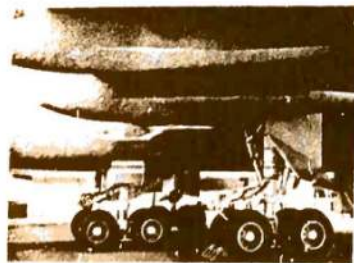



9

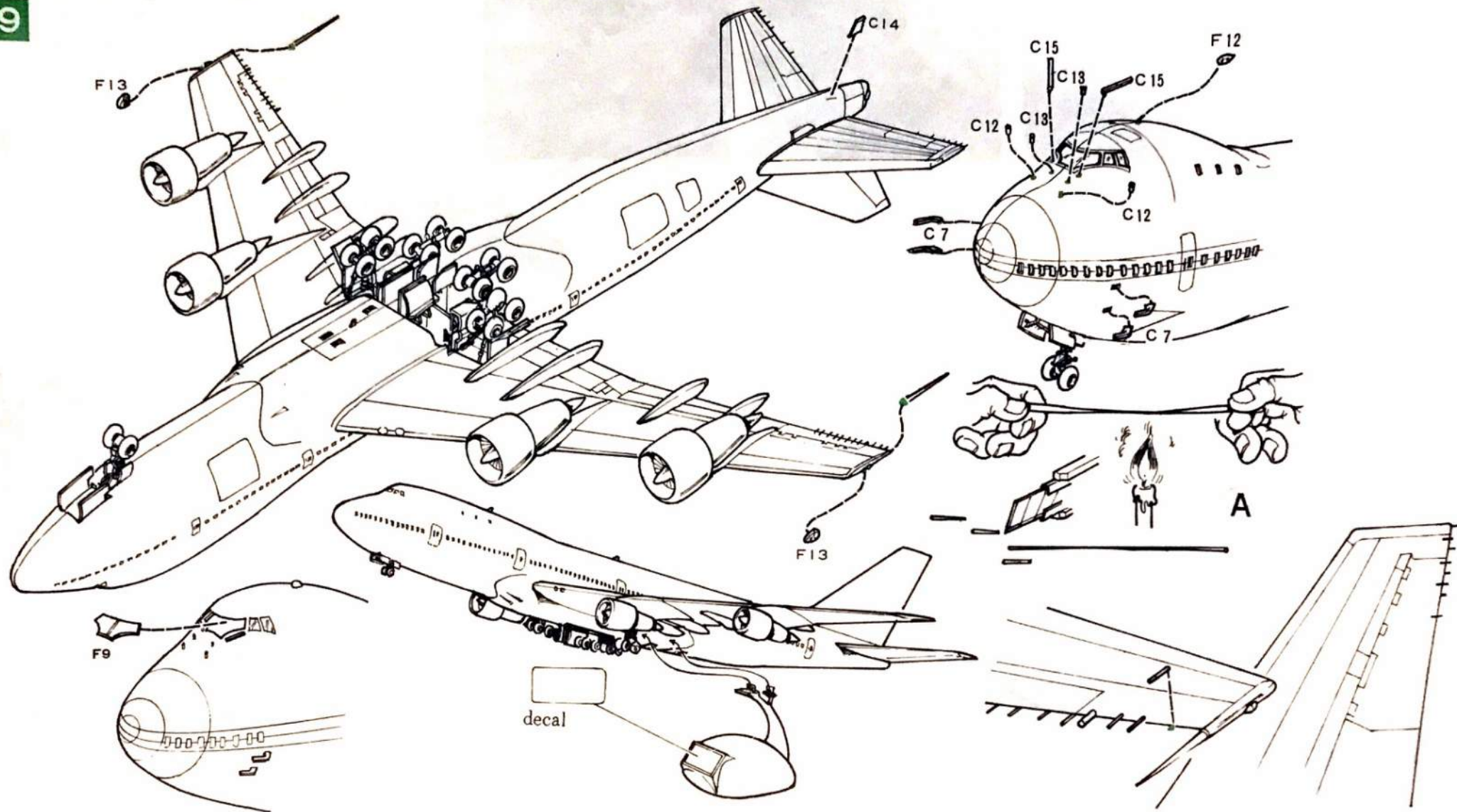

9

Cement small parts in place as shown. Wing tip antennas are made by cutting a small strip of plastic and heating and stretching as shown in A. Cut and cement to the trailing edge of the wing. Display on stand or chocks after decorating.

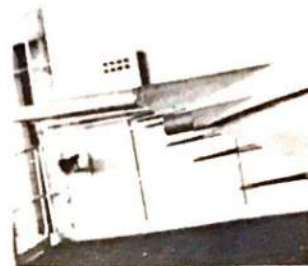



## PAINTING DECALS

Apply decals on the upper and underside of wings as per figure.  
(Paint first if required.)

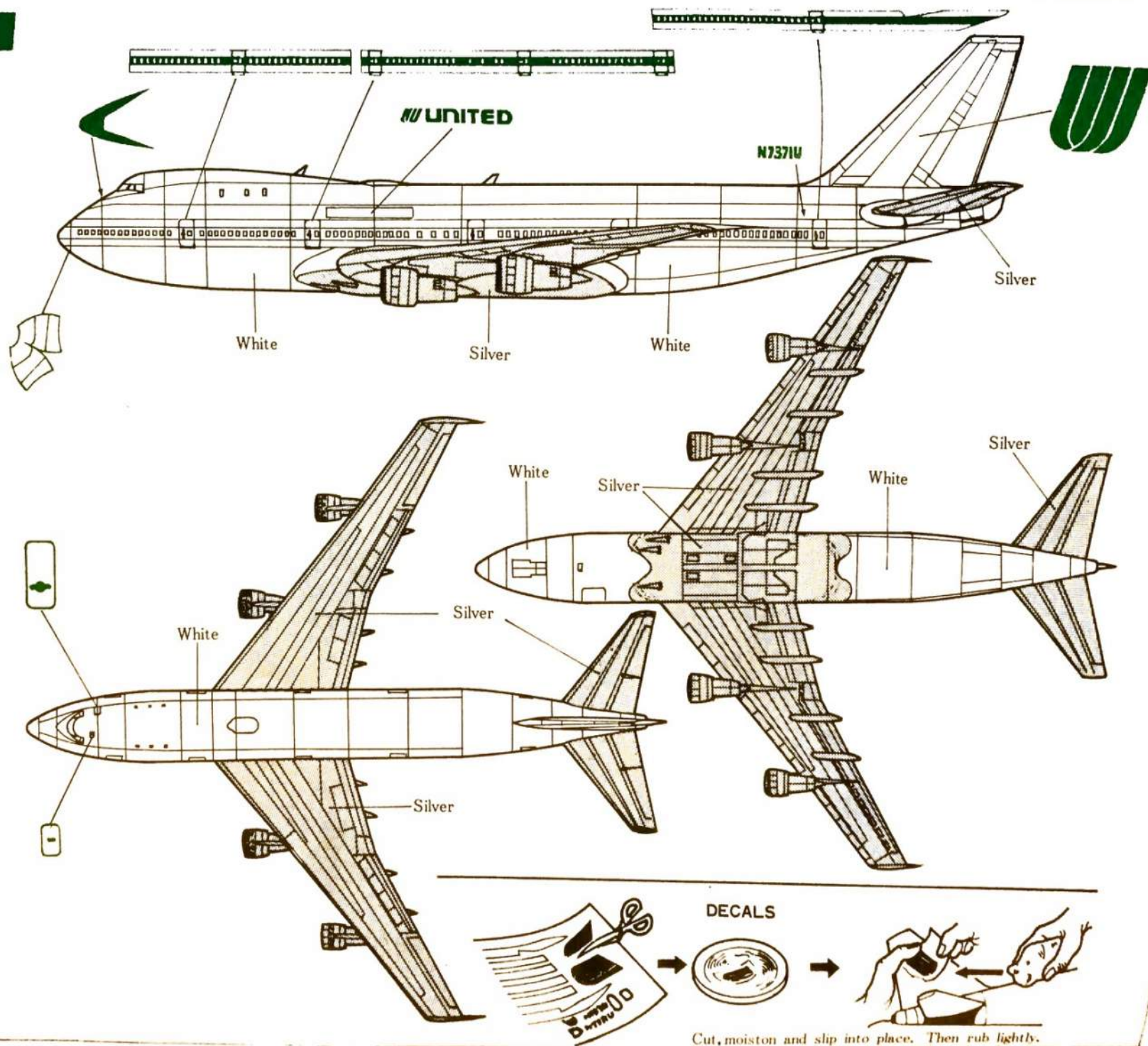

Cut, moisten and slip into place. Then rub lightly.





Unique 8½" **DERAILLEUR RACING BIKE**

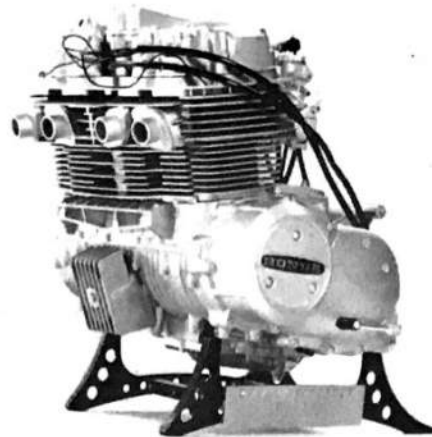

Operating Model **HONDA 750 ENGINE**

Unique Pistonless **Wankel Rotary Engine**

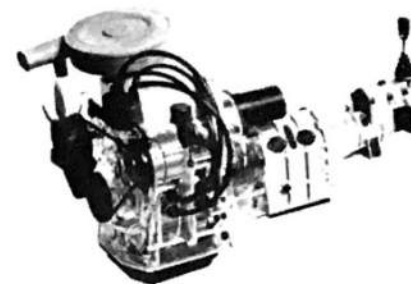

Printed in Japan



The Luxurious Prince Alphonso **1919 Hispano-Suiza**

Cutty Sark, World's Fastest **China Clipper**

ALSO

available at your favorite hobby store.

- 1907 Itala
- WORLD'S FIRST DUNE BUGGY**
- 100th Anniversary Edition
- 1872 VULCAN
- The World's Largest Airliner
- LOCKHEED 500
- The classic Sports Car
- M.G.T.C

Fabulously Detailed **MERCER RACEABOUT**

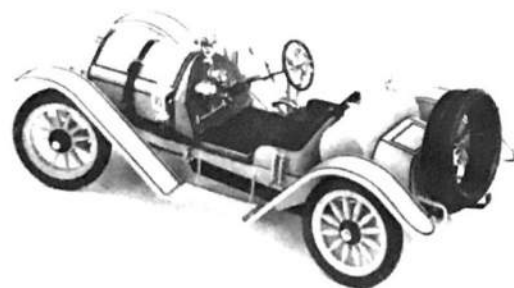
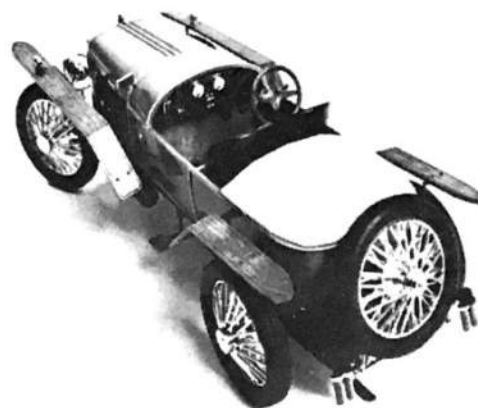

For a copy of the Entex catalog, please send 50¢ to:  
**Entex Industries, Inc.**  
1016 East Burgrove  
Carson, California 90746

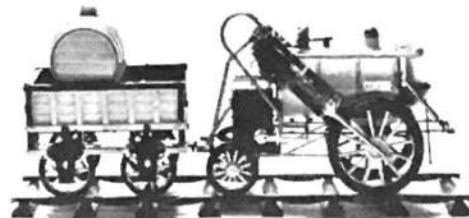

George Stephenson's 1829 "Rocket" **1st Passenger Engine**

