

**CAMO A**

HA-1112 M-1L Buchón, alias Bf 109E, žlutá 15, fiktivní jednotka Luftwaffe ve filmu Bitva o Británii.

HA-1112 M-1L Buchón, aka Bf 109E, Yellow "15", fictive Luftwaffe unit that flew in the Battle of Britain movie.

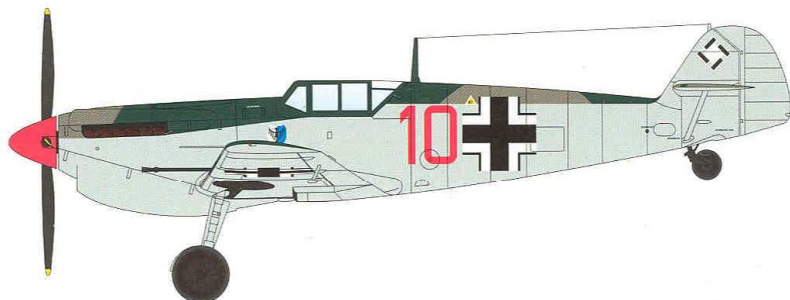

**CAMO B**

HA-1112 M-1L Buchón, alias Bf 109E, červená 10, fiktivní jednotka Luftwaffe ve filmu Bitva o Británii.

HA-1112 M-1L Buchón, aka Bf 109E, Red "10", fictive Luftwaffe unit that flew in the Battle of Britain movie.

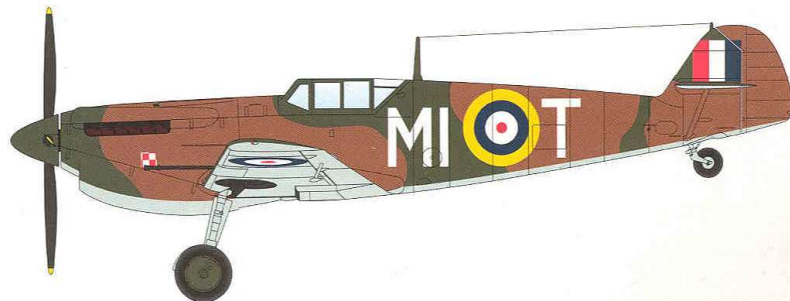

**CAMO C**

HA-1112 M-1L Buchón, alias Hurrischmitt, MI-T, fiktivní polská jednotka RAF ve filmu Bitva o Británii, vyzbrojená Hurricany.

HA-1112 M-1L Buchón, aka Hurrischmitt, MI-T, fictive Polish RAF squadron equipped with Hurricanes that flew in the Battle of Britain movie.

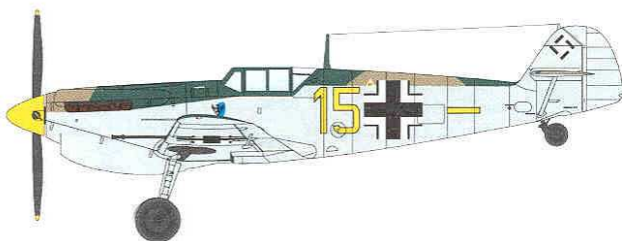

## HA-1112 M-1L Buchón

### “Movie Star”

GB

Spanish dictator Francisco Franco owed Italian fascist and German nazis a great deal for the successful coup, but he did not let them pull him into the Second World War. On the other hand, that did not prevent him from purchasing weapons of German origin or buying licence rights for their production. And it was also the case of the Bf 109 F/G production in Spain. To ease the start of the type's mass production, several built Bf 109G airframes were delivered, however sans their power units and also lacking some other equipment. It was not considered a big problem to produce the aircraft themselves in Spain, but the engines were to be delivered from Germany. The deliveries eventually failed however and the domestic team had to find a way out of the shortage of the original engines. At first, they intended to test their own power unit, the HS-12Z-89 engine which went through a long and rather complicated series of trials in both the Bf 109E and Bf 109G airframes (known as the C.4J) with radiators redesigned per Spanish requirements. All this effort almost came in vain as the production would not start until 1949 giving only a small series of the HA-1109 K-1L/C-4J with a French power unit HS-12Z-17 built also under a licence. And yet the engine-less airframes had been waiting since 1944. The usage of the de Havilland Hydromatic propeller also did not allow for the cannon to be built into the engine block firing through the propeller shaft, so the type's wing had to be redesigned to be able to carry a pair of HS-404/408 cannon. The main development version, however, was the later type with completely different engine. In the early fifties the relations between Spain and West European countries improved and as Britain lifted her embargo in 1953, Spain was allowed to purchase Merlin 500/45 engines which became to be used in the modified messerschmitt airframes. During 1955-56, the Spanish Air Force received 171 of the new HA-1112 M-1L/C-4K Buchón (Pigeon), the version which was not to be used in a fighter role, its main raison d'être being rather in ground attack missions. Besides their cannon armament, the type carried also underwing rocket projectiles and armed such, the Buchón saw action in suppressing insurgent forces in Spanish Morocco in 1958-60. Two-seat trainer prototypes were also built, both with the HS-12Z-17 engine and with the Merlin 500/45. During the mid 60s, Buchóns were transferred to training and reserve units. But their finest hour was yet to come. About 15 Buchóns along with Spanish licence-built He 111s (CASA 2.111) were used for the filming purposes during shooting of the Battle of Britain movie in 1968. To resemble the Bf 109 the film Buchóns were modified by the addition of squared wing tips, mock up wing weapons and tailplane struts. Of interest might be also the fact that during the filming the Buchóns were used not only as German aircraft but also to increase the Hurricane fleet when they flew in the background. Several Buchóns even survived the filming and participated in other films, too. Some of them keep flying until today as Warbirds.

TTD:

Wingspan (combat aircraft): 9,92 m, Length: 9,10 m, Max. Speed: 660 kmh, Service Ceiling: 10 200 m, Range: 765 km.

CZ

Španělský diktátor Franco sice vděčil italským fašistům a německým nacistům za úspěšný převrat, ale do bojů druhé světové války se zatáhnout nenechal. To mu ale nebránilo nakupovat od hitlerovského Německa zbraně nebo jejich licence. Takto nakoupil i licenci stíhačky Bf 109F/G. Pro snažší rozběh sériové výroby byly dodány i draky Bf 109G, ovšem bez motorů a dalšího vybavení. Výroba vlastních letadel nebyla ve Španělsku problém, ale motory mělo dodávat Německo. K tomu nedošlo a tak si Španělé museli pomoci sami. Nejprve otestovali domácí motor HS-12Z-89. Prošel komplikovanými a dlouhými zkouškami, nejprve v Bf 109E a později v Bf 109G (označovaným jako C.4J) s upravenými chladiči dle španělského návrhu. To vše bylo prakticky k ničemu, protože až v roce 1949 se rozeběhla montáž malé série HA-1109 K-1L/C-4J s francouzskou licenční verzí motoru HS-12Z-17. Přitom draky čekaly na motory od roku 1944! Použití vrtné de Havilland Hydromatic neumožňovaly montáž kanonů do hlídek vrtné. Proto bylo křídlo stíhaček překonstruováno tak, aby mohlo nést dva kanóny HS-404/408. Hlavní vývojovou verzí se ale stal až následující typ s úplně jiným motorem. Na počátku padesátých let došlo k oteplení vztahů mezi Španělskem a západoevropskými státy. Díky uvolněnému embargu ze strany Velké Británie se v roce 1953 podařilo nakoupit britské motory Merlin 500/45. Tyto motory se začaly montovat do upravených draků messerschmittů. V letech 1955-56 tak španělské letectvo dostalo 171 kusů nové verze HA-1112 M-1L/C-4K Buchón (Holub). Stroje samozřejmě nemohly být používány jako stíhací, jejich posláním byly bitevní akce. Pro tyto účely nosily mimo kanónů i podvěšené rakety. Ty byly také použity proti povstalcům ve Španělském Maroku v letech 1958-60. Postaveny byly také prototypy dvoumístných cvičných strojů, jak s motorem HS-12Z-17, tak s motorem Merlin 500/45. V polovině šedesátých lety byly Buchóny přesunovány ke cvičným účelům a do zálohy. Ale jejich hvězdná hodina měla teprve přijít. V roce 1968 při natáčení filmu Bitva o Británii bylo společně se španělskými licenčními He-111 (CASA 2.111) pro účely natáčení použito cca 15 kusů Buchónů. Filmové Buchony byly upraveny montáží hranatých koncových oblouků, maket zbraní a vzpěr VOP do podoby Bf 109E. Zajímavé je, že při natáčení nehrály jen Němce, ale ve formacích vytvářely i kompars v pozadí Hurricanů, aby zvětšily jejich formace. Část Buchónů přežila natáčení a zahrála si i v dalších filmech. Některé jako Warbirds létají dodnes.

Tech. údaje: rozpětí (bojových strojů): 9,92 m, délka: 9,10 m, max. rychlost: 660 km/h, dostup: 10 200 m, dolet: 765 km.

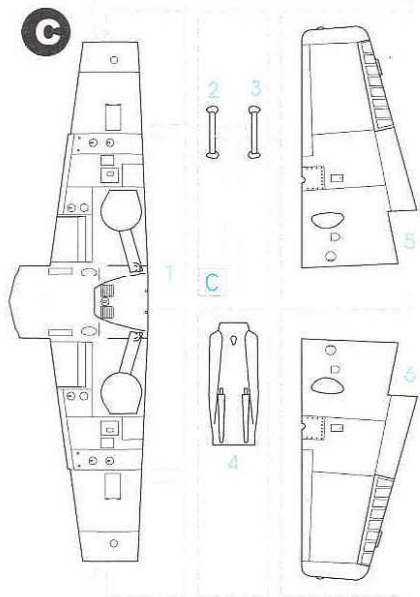
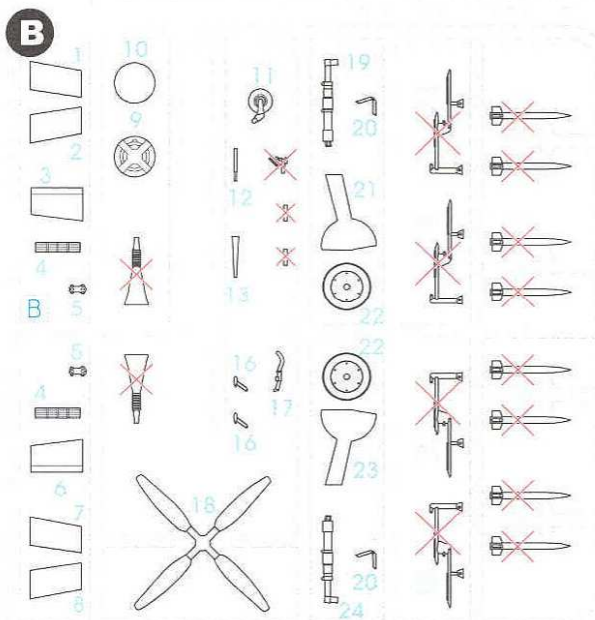
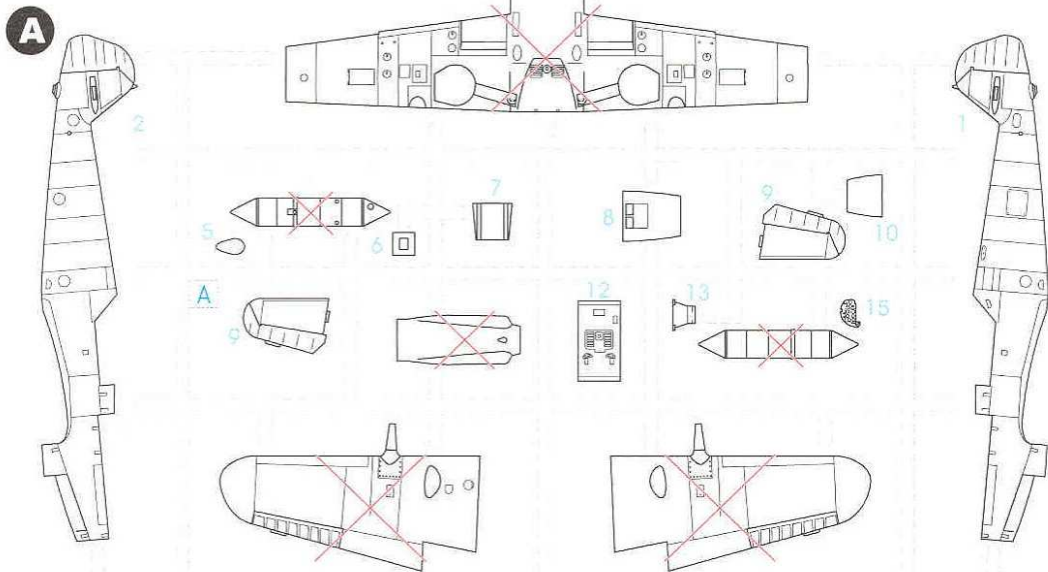

**PUR Parts (PUR)**



**Clear Part (CP1)**



**Film**



**Photo-Etched Parts (L1-L26)**

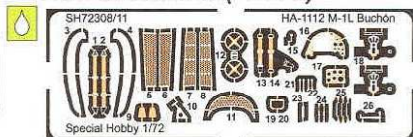

**SYMBOLS**

**?** MOŽNOST VOLBY  
OPTIONAL  
NACH BELIEBEN  
OPTION

**👉** POUŽÍT KYANOAKRYLÁTOVÉ LEPIDLO  
INSTANT CYANOACRYLATE GLUE  
ZYANOAKRYLÁTKLEBER  
ADHESIF CYANOACRYLAT

**👉** OHNOUT  
BEND  
BIEGEN  
COURBER

**👉** ZHOTOVIT NOVÉ  
SCRATCH BUILD  
FERTIGSTELLEN  
ACHEVER

**👉** ŘEZAT/VRTAT  
CUT OFF/DRILL  
ENTFERNEN  
DETACHER

**A** NATŘÍT  
COLOUR  
FARBEN  
PEINDRE  
GSI colours code

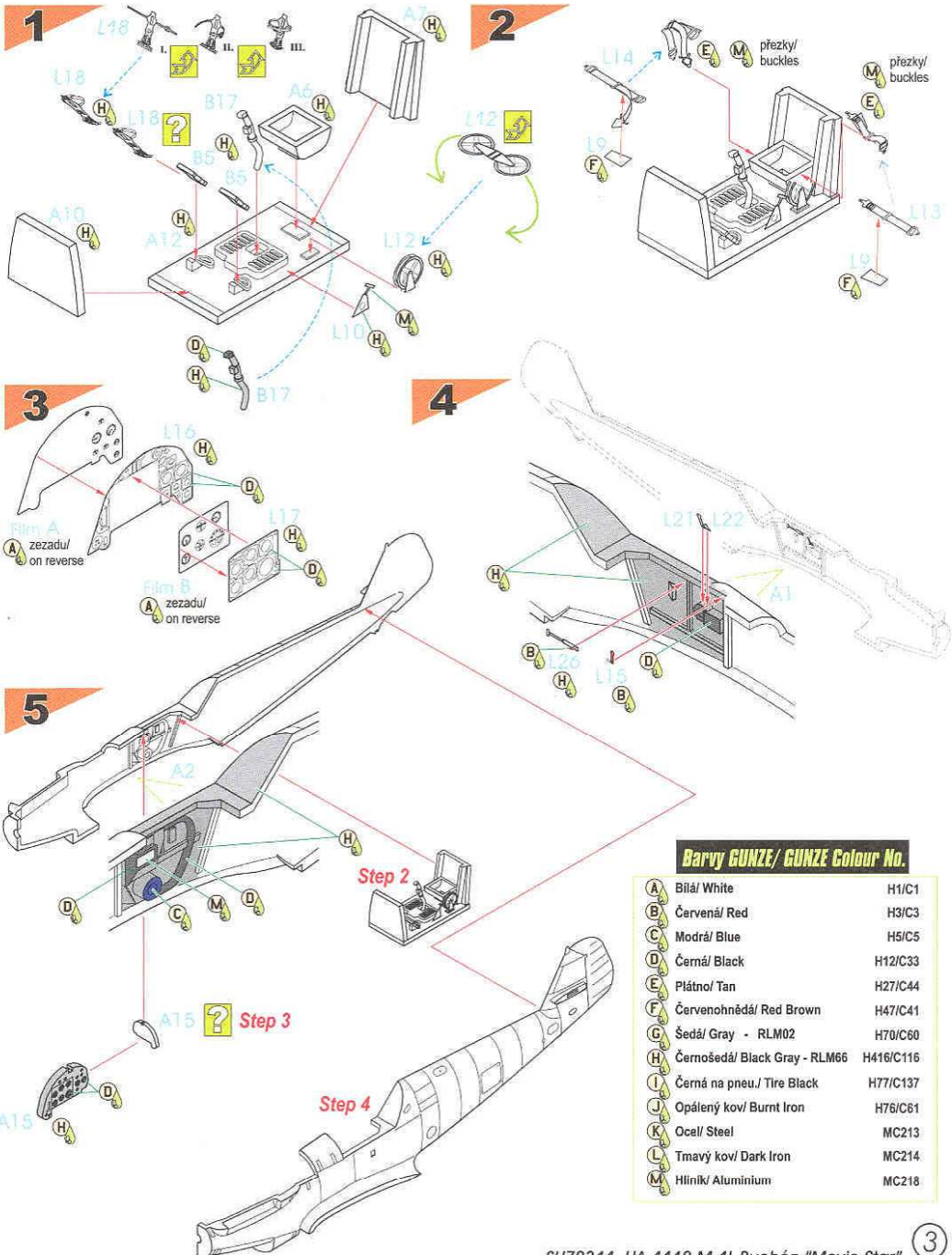

**Barvy GUNZE/ GUNZE Colour No.**

<b>A</b>	Bílá/ White	H1/C1
<b>B</b>	Červená/ Red	H3/C3
<b>C</b>	Modrá/ Blue	H5/C5
<b>D</b>	Černá/ Black	H12/C33
<b>E</b>	Plátno/ Tan	H27/C44
<b>F</b>	Červenohnědá/ Red Brown	H47/C41
<b>G</b>	Šedá/ Gray - RLM02	H70/C60
<b>H</b>	Černošedá/ Black Gray - RLM66	H416/C116
<b>I</b>	Černá na pneu/ Tire Black	H77/C137
<b>J</b>	Opálený kov/ Burnt Iron	H76/C61
<b>K</b>	Ocel/ Steel	MC213
<b>L</b>	Tmavý kov/ Dark Iron	MC214
<b>M</b>	Hliník/ Aluminium	MC218

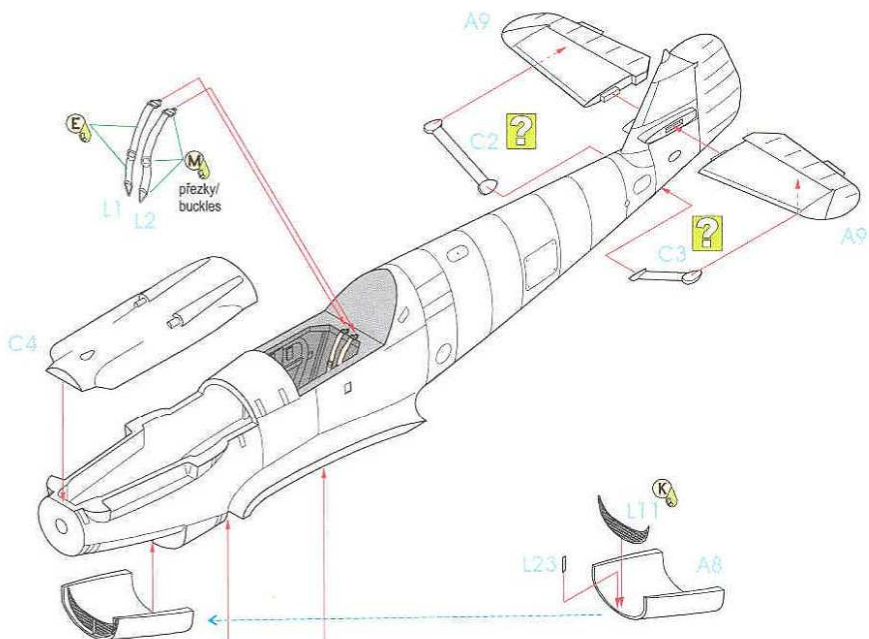
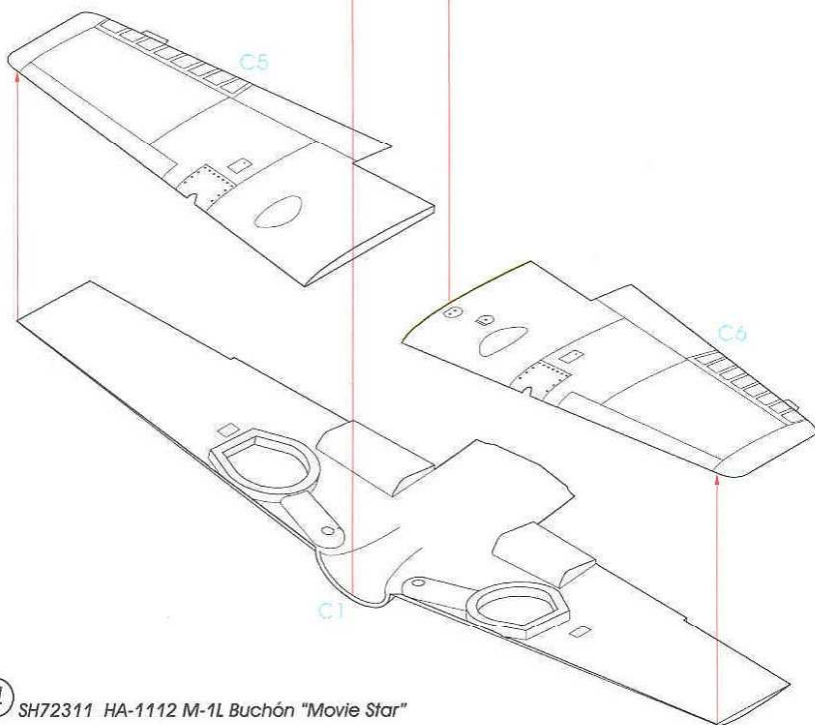
**6****7**

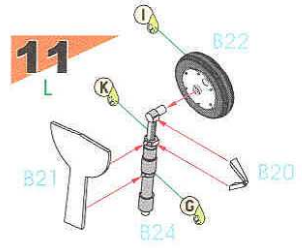
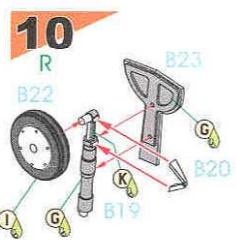
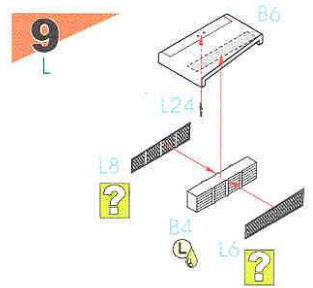
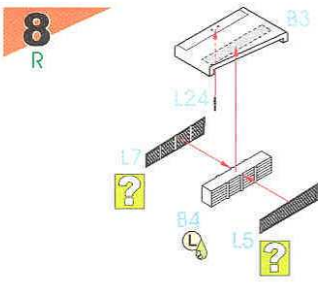

**12**

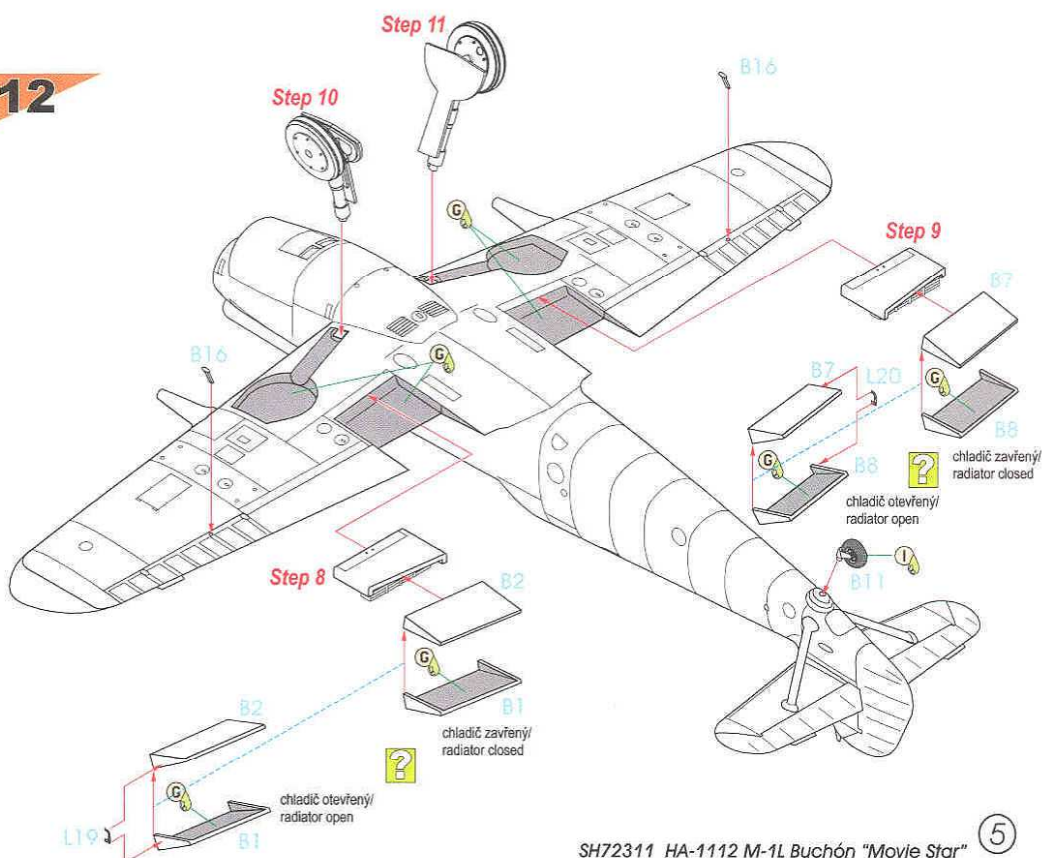

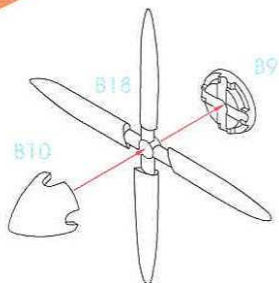
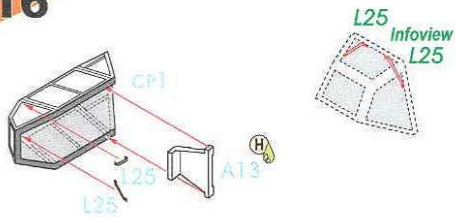
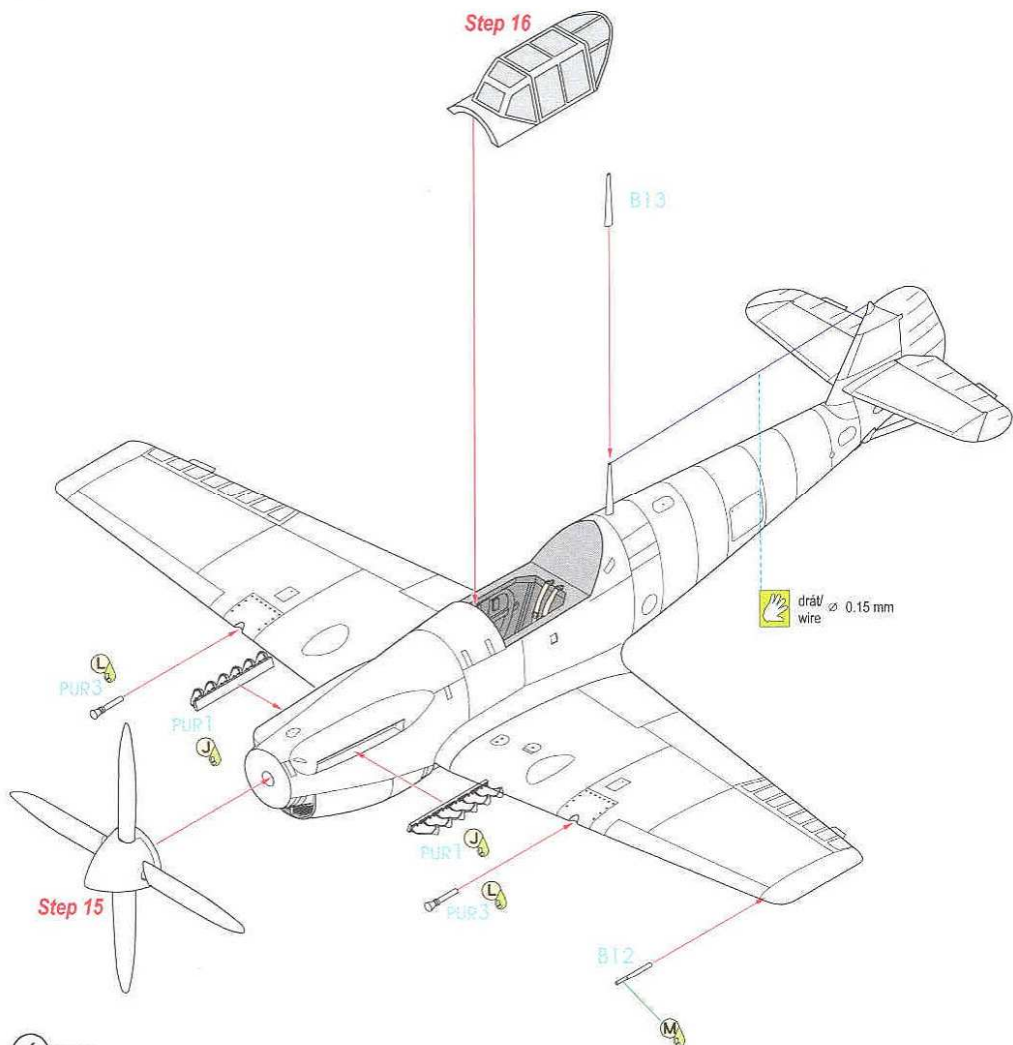
**15****16****17**

6

CAM. A

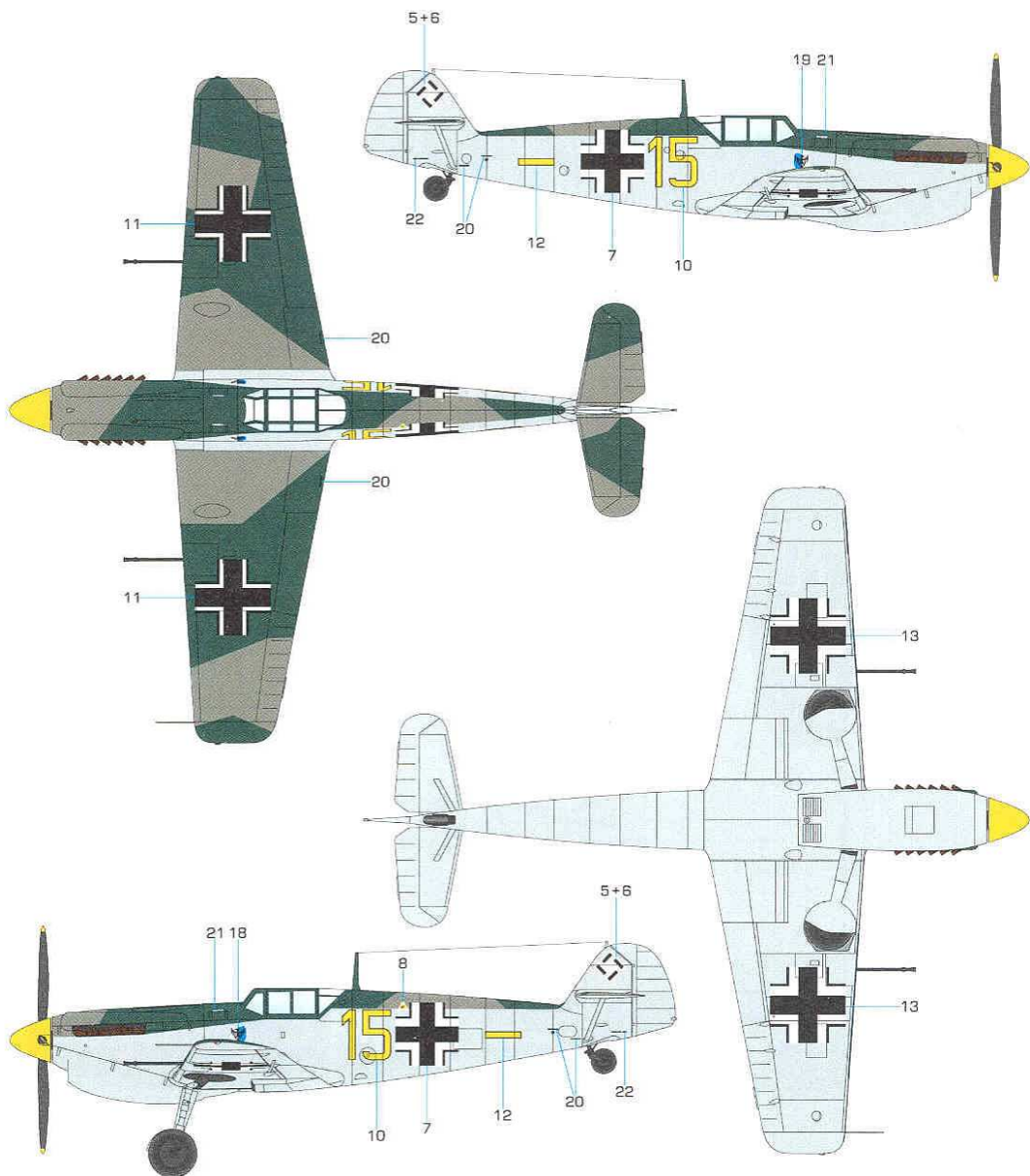

 Tmavá zelená  
 Dark Green  
 H64/C17  
 RLM 71 Dunkelgrün

 Šedozelená  
 Grey  
 H70/C60  
 RLM 02 Grau

 Světlá modrá  
 Light Blue  
 H67/C115  
 RLM 65 Lichtblau

 Černá  
 Black  
 I113/C33

 Žlutá  
 Yellow  
 C113  
 RLM 04 Gelb



CAM. B

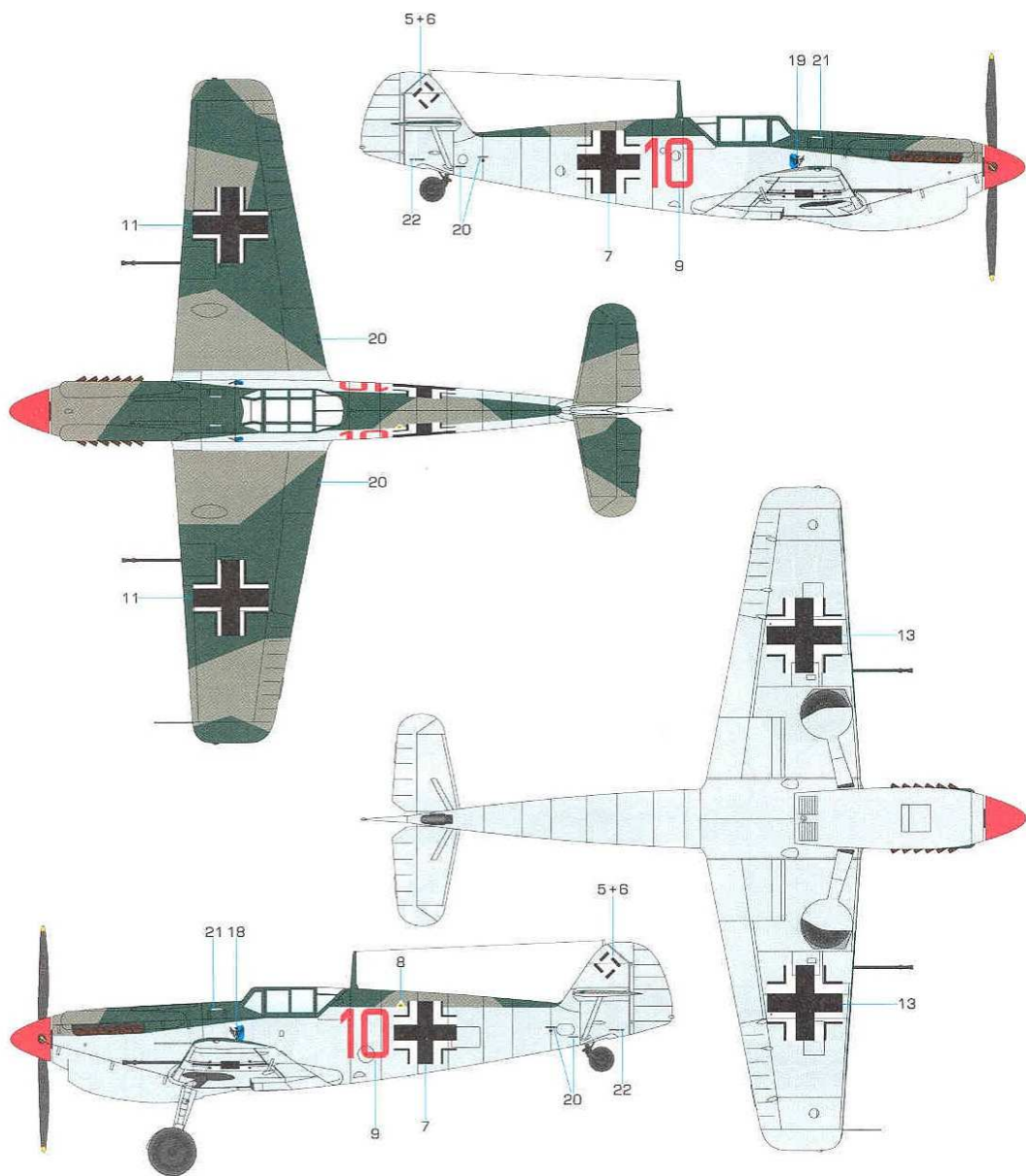

Tmavá zelená  
 Dark Green  
 H64/C17  
 RLM 71 Dunkelgrün

Šedo-zelená  
 Grey  
 H70/C60  
 RLM 02 Grau

Světlá modrá  
 Light Blue  
 H67/C115  
 RLM 65 Lichtblau

Černá  
 Black  
 H13/C33

Červená  
 Red  
 H13

CAM. C

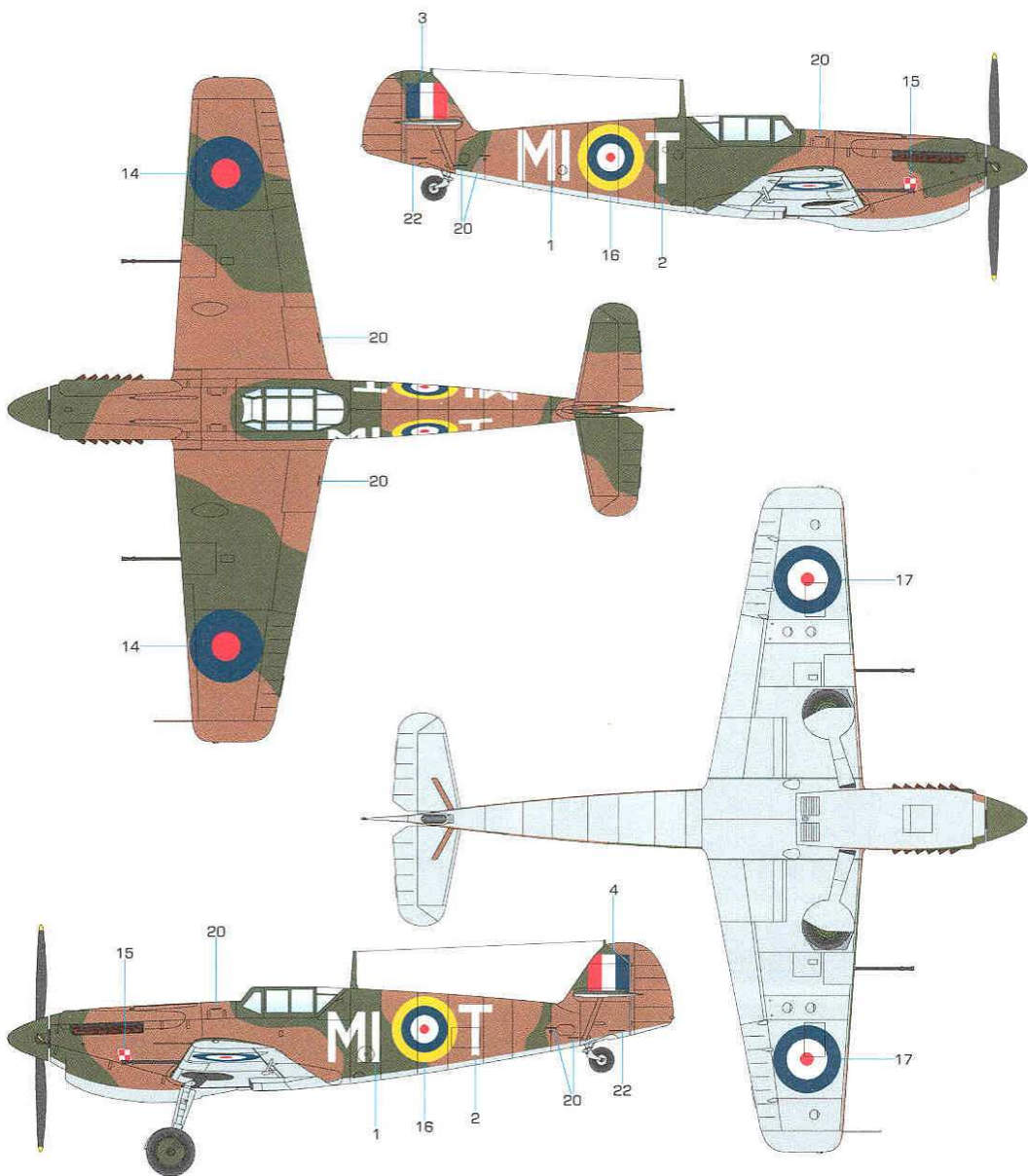

 Tmavá zelená  
Dark Green  
H73/C23

 Tmavá zemitá  
Dark Earth  
H72/C22

 Světlá modrá  
Light Blue  
H67/C115

 Černá  
Black  
H13/C33

**SH72099**



**Supermarine Seafire FR.Mk.47**

**SH72112**



**C-60 Lodestar**

**SH72161**

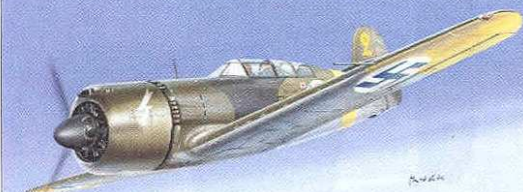

**VL Myrsky II**

**SH72175**



*"Netherlands East  
Indies Air Force"*

**Koolhoven FK-51**

**SH72179**

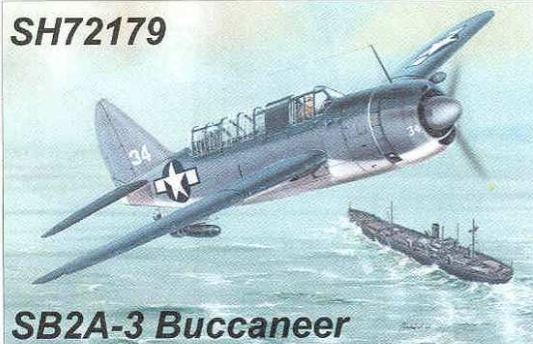

**SB2A-3 Buccaneer**

**SH72214**



**D-558-I Skystreak "NACA"**

**SH72229**



**Supermarine Seafire Mk.45**

**SH72243**



*"Perseus Engine Version"*

**Vickers Vildebeest Mk.IV**

**SH72245**



*"Two-Seater"*

**Yakovlev Yak-23UTI**

**SH72247**



**G-23 Delfin** *"Spanish Civil War"*

**SH72262**



**P-35** *"War Games and War Training"*

**SH72263**



*"What If-War"*  
**Messerschmitt Me 163C**

**SH72268**



**V-156B Chesapeake Mk.1**

**SH72274**



**AH-1G Cobra** *"Spanish & IDF Service"*

**SH72279**

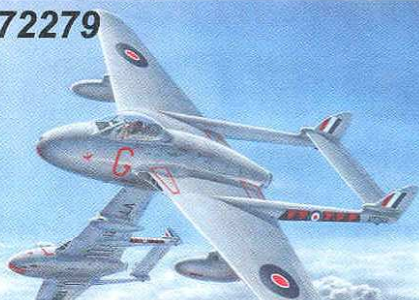

**D.H.100 Vampire F Mk.3**

**SH72309**



*"Italian Adventure in Russia"*  
**Caproni Ca.311M**

SH72319

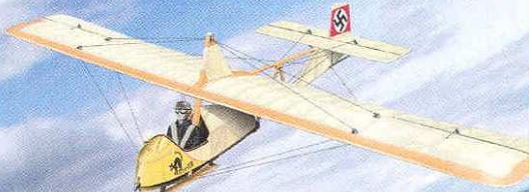

"German and Slovak Service"

**SG 38 Schulgleiter**

SH72330



"Czechoslovak Floatplane"

**Letov Š.328v**

SH72337



**A-20B/C**

"Boston with UTK-1 Turret"

SH72350



"The Final Version"

**SB2C-5 Helldiver**

SH72361



"World Speed Record"

**Gloster Meteor Mk.4**

SH72368



**Fairey Fulmar Mk.II/NF Mk.II**

**USE CMK TOOLS AND WEATHERING PIGMENTS FOR YOUR KITS.**

H1010 HANDLE FOR OUR SAWS  
- PRICELESS TOOL FOR RESIN  
PARTS ADJUSTMENT



H1011 CMK SANDING STICK  
- FOUR DIFFERENT GRIT  
OF SANDING PAPERS ON  
ONE SANDING STICK.



**Star Dust**  
weathering pigments