

Supermarine Spitfire Mk.Vc Trop RAAF

SW 72045 scale: 1/72



Sky-high piles of books have been written about one of the best British fighters - Supermarine Spitfire.

Following the Battle of Britain in 1940, the Royal Air Force had planned to replace its Spitfire Mk. I and II fighters with the Mk. III.

The development of this version took too long, and when Luftwaffe has introduced Messerschmitt Bf-109F, RAF had to make an interim version - Mk.V. Basically, the Mk. V consisted of a modified Mk. II airframe with a new Rolls-Royce Merlin 45 engine (followed by other Merlin versions).

The first Mk V was produced in January 1941, and tests showed it to be almost as good as the Mk III, but without the extra complexity in that version. In March 1941 it was decided to produce the Mk V instead of the Mk III. The type had already entered production by this stage, with No. 92 squadron being the first to receive it in February 1941. Production was initially divided between the Va with the eight machine gun "a" wing (94 built) and the Vb with the "b" wing of two 20mm cannon and four machine guns. In October 1941 the Mk Vc appeared. This used the universal "c" wing developed for the Mk III, which could carry either eight machine guns, four 20mm cannon or two cannon and four machine guns. The two cannon/ four machine gun combination was most common, as the four cannon version was significantly heavier, reducing performance.

The Mk V was the first Spitfire to be used in large numbers outside Britain - Malta, Africa, Australia, USSR. For some of these theatres of war, the RAF tropicalized (Trop) the Spitfire Mk. Vs by adding Vokes or Aboukir air filter. MK.V was also used by Eagle Squadrons in RAF.

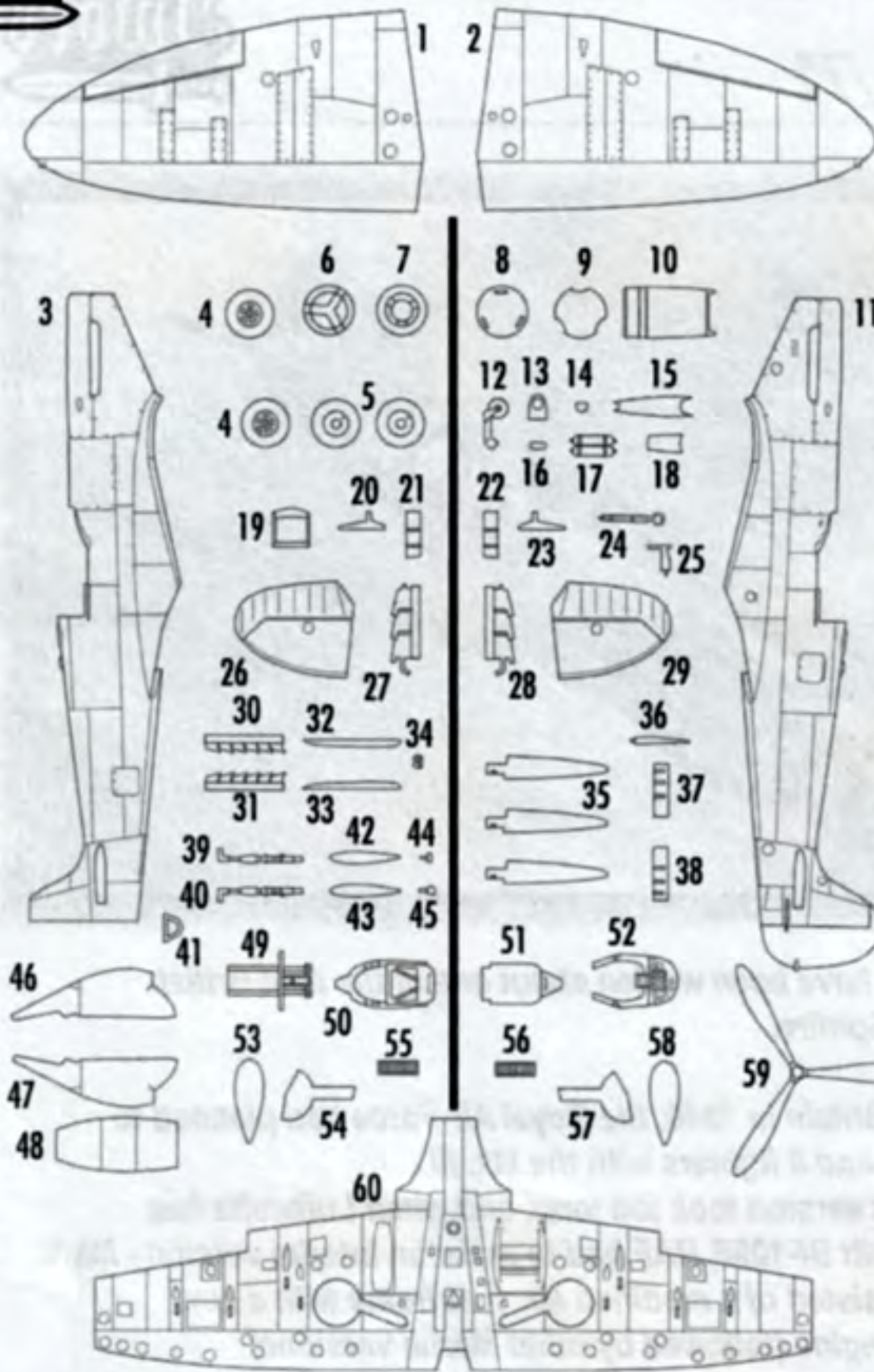

URETHAN

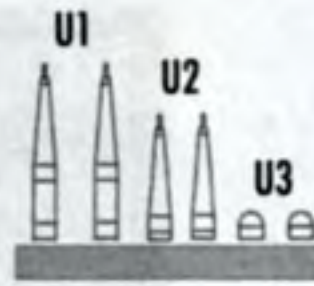

CLEAR

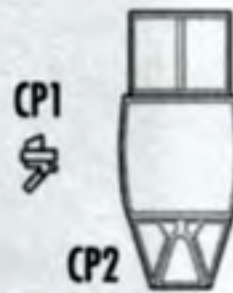

PHOTO-ETCHED PARTS



BARVA/COLOR

- (A) Černá/Black
- (B) Interierová zelená
Interior Green
- (C) Stříbrná/Silver
- (D) Hliník/Aluminium
- (E) Světle šedá/
Light Grey
- (F) Červená/Red
- (G) Žlutá/Yellow
- (H) Zelená/Green
- (I) Černošedá/
Tyre Black
- (J) Špinavý hliník/
Dirty Aluminium
- (K) Chromová/
Chrome
- (L) Hnědá/Brown
- (M) Kovová/Gun metal
- (N) Dřevo/Wood
- (O) Rezavá/Rust

STEP 1

UPRAVIT
REDUCE

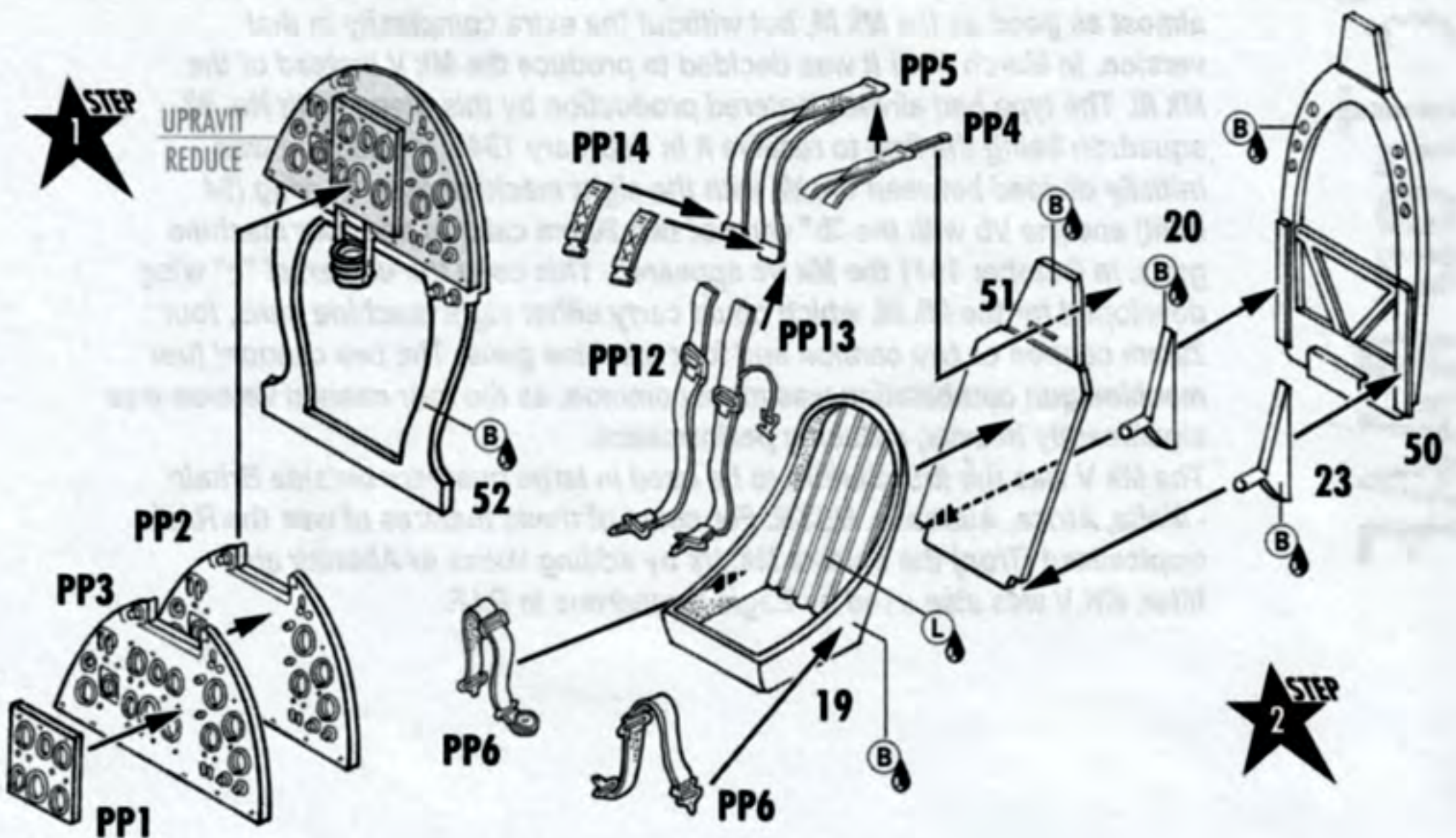

STEP 2

STEP 3

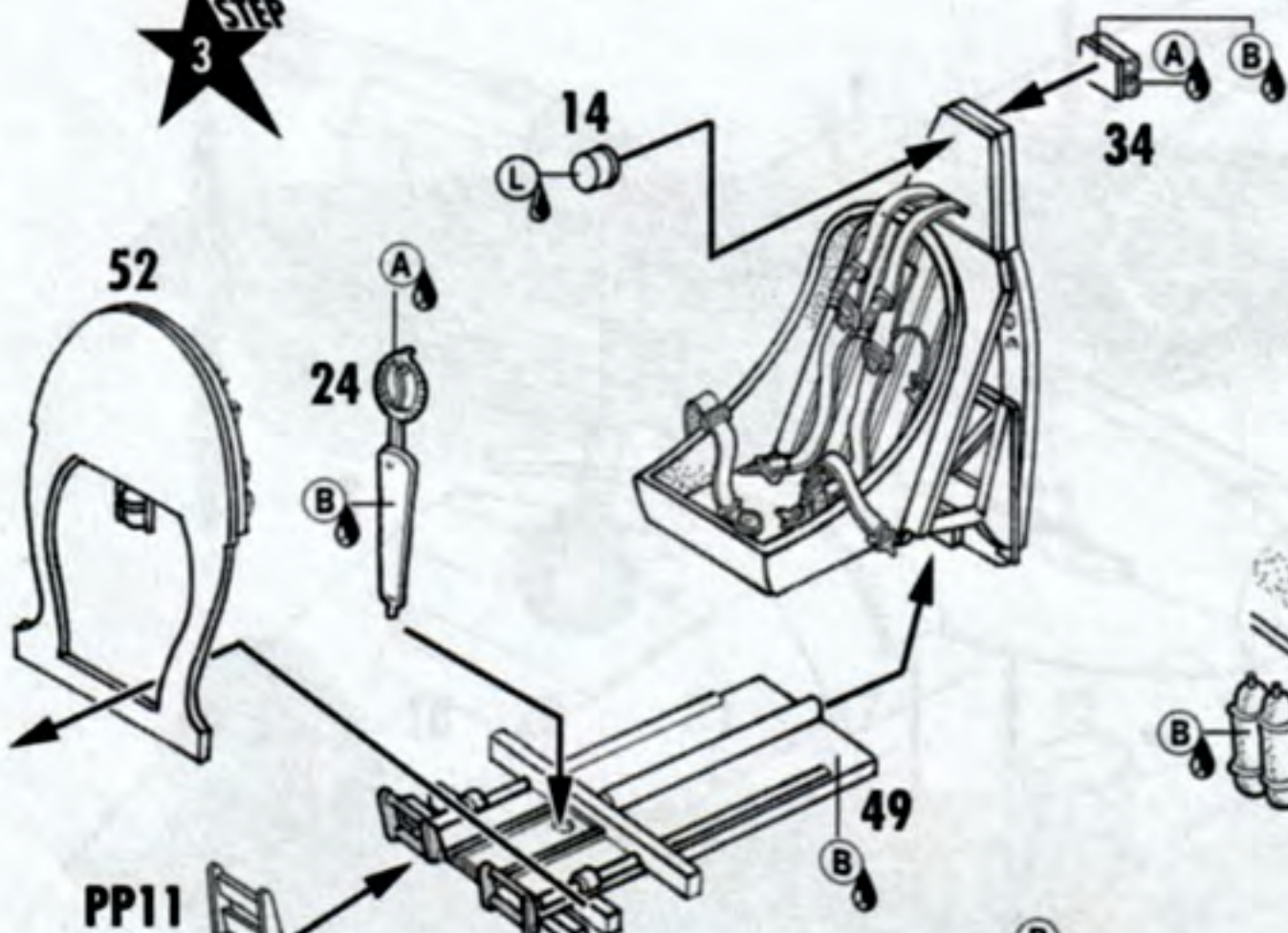

STEP 4

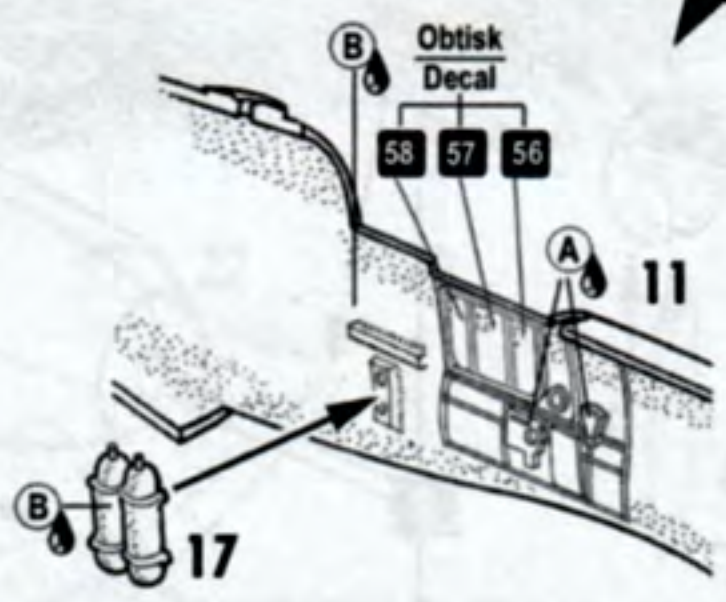

STEP 5

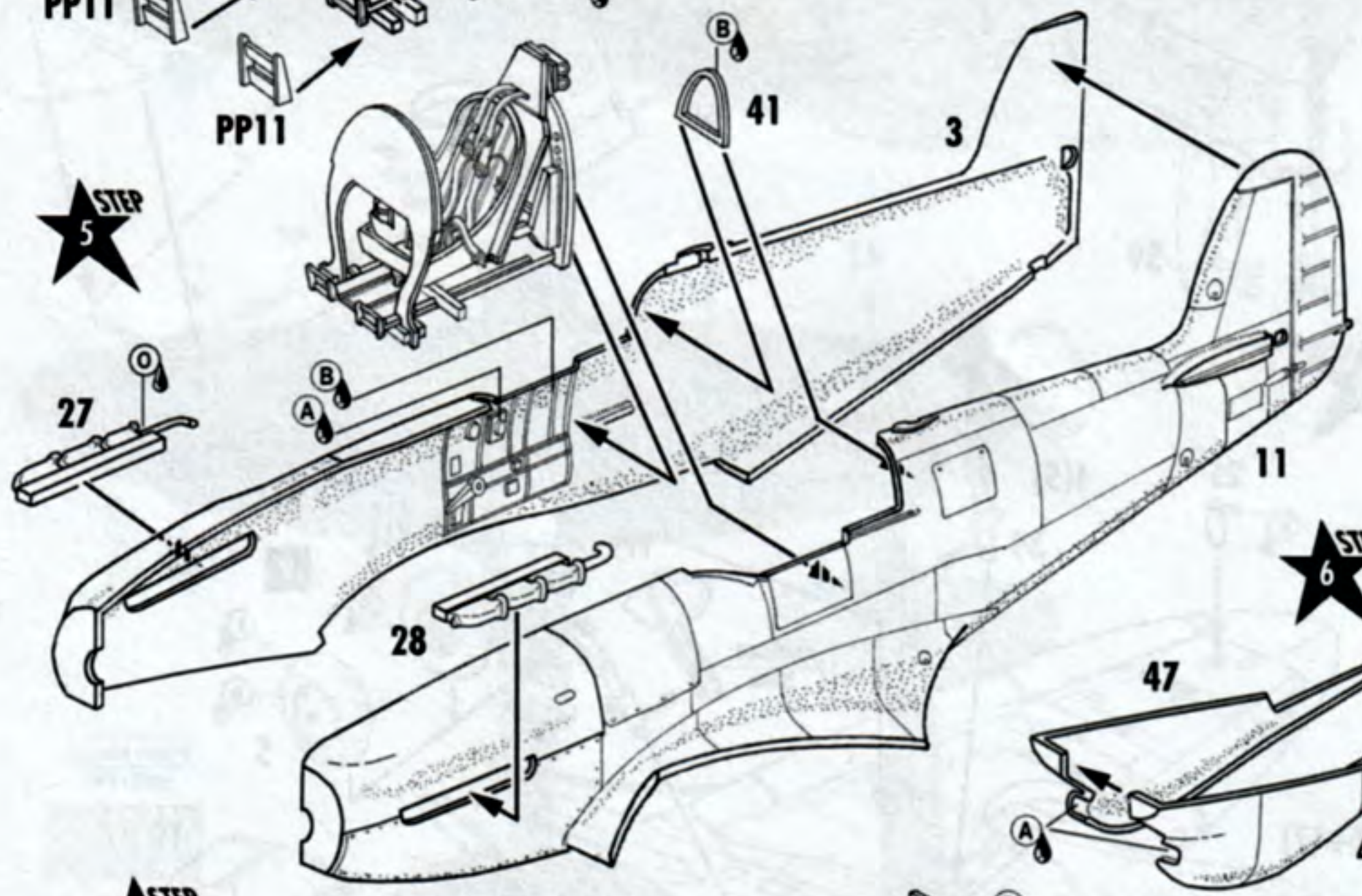

STEP 6

STEP 7 a

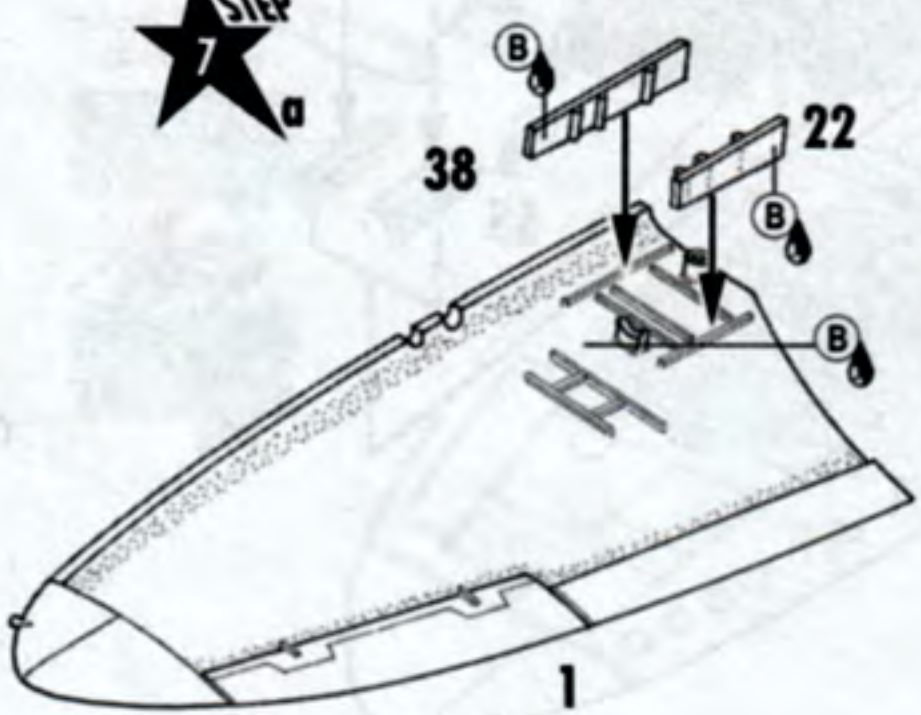

STEP 7 b

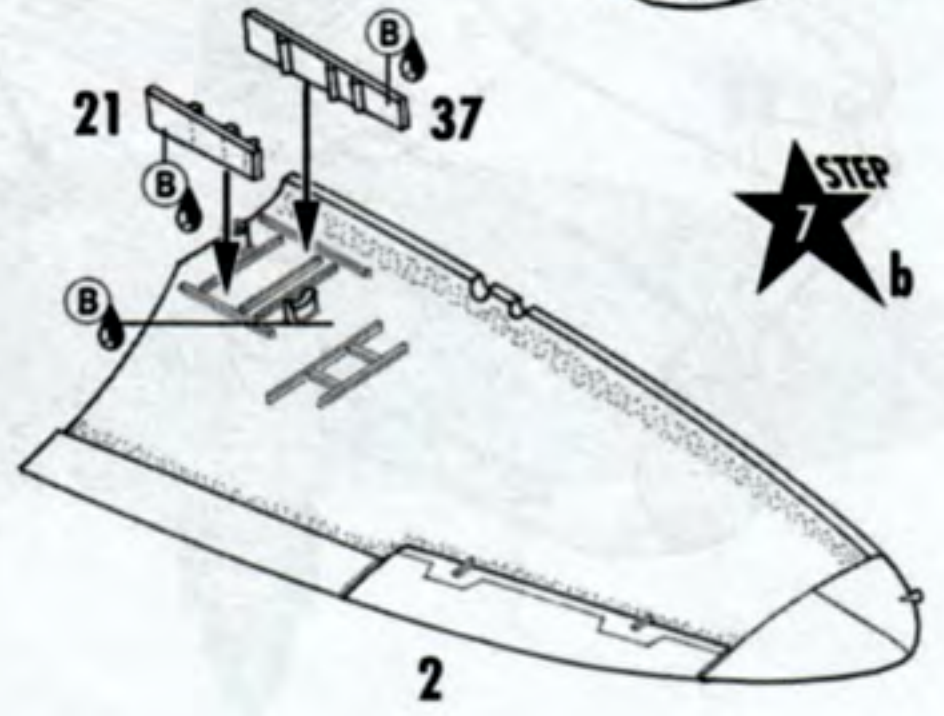

8 STEP

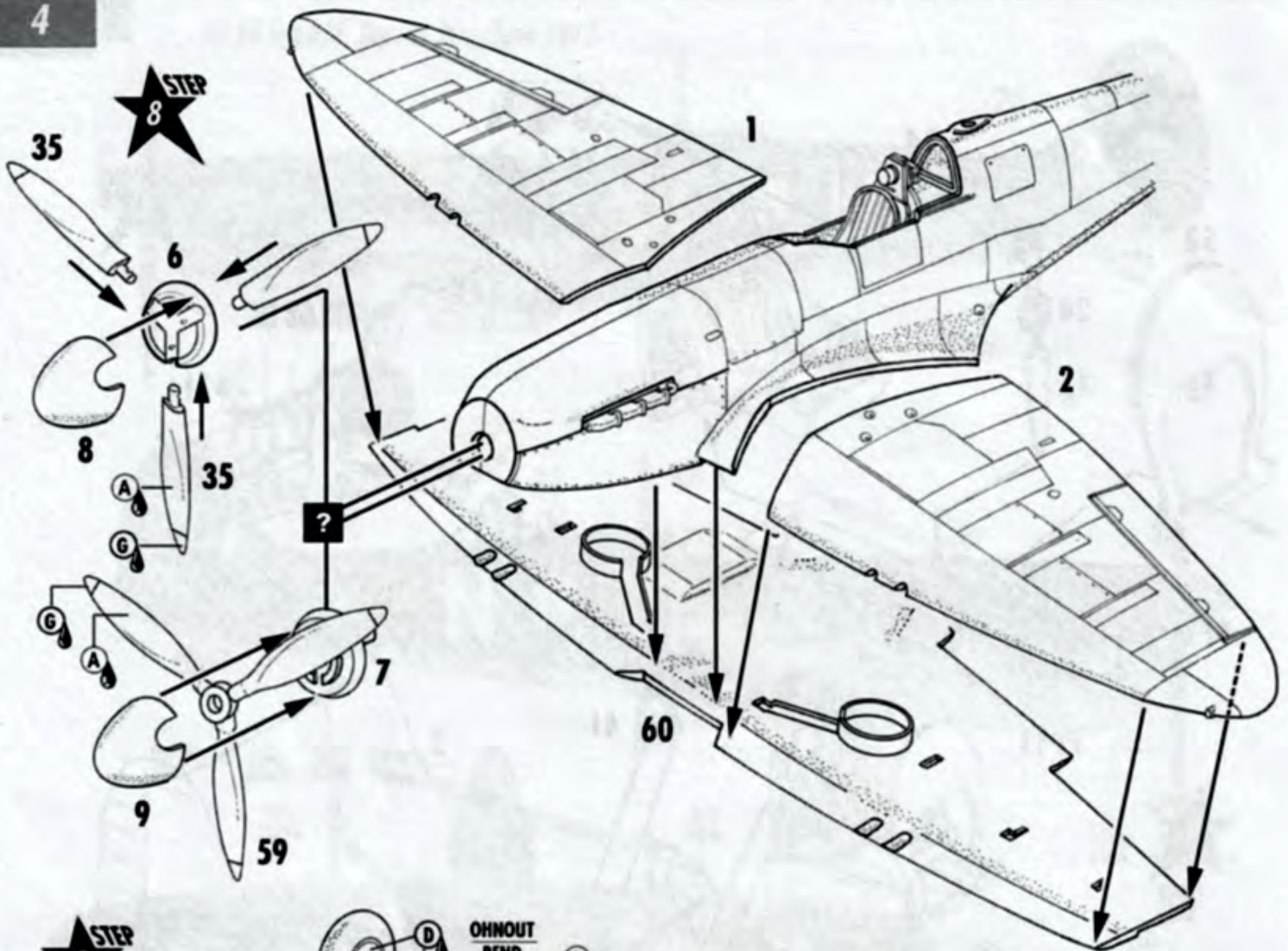

9 STEP

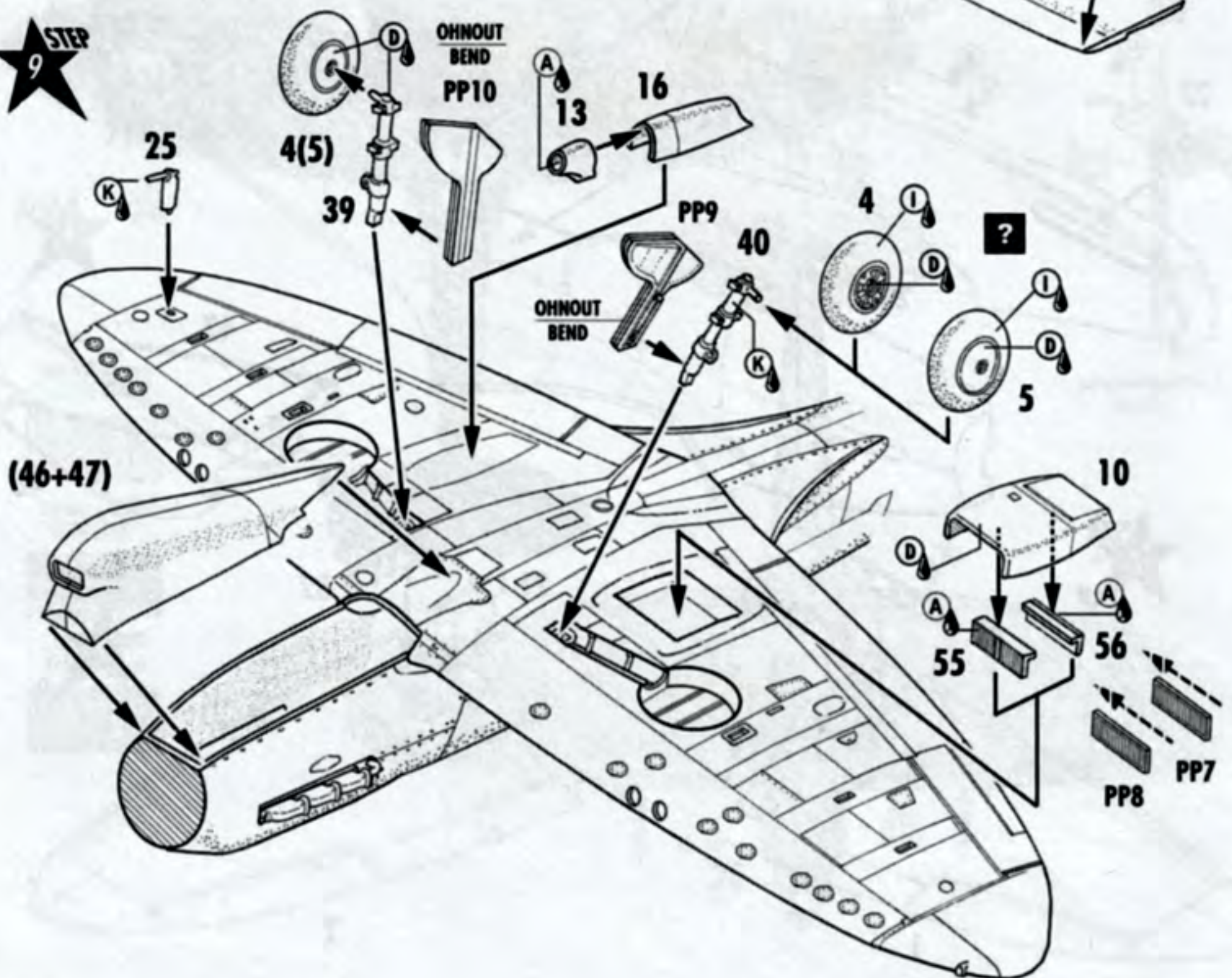

KAMO: UP-X,
QY-V

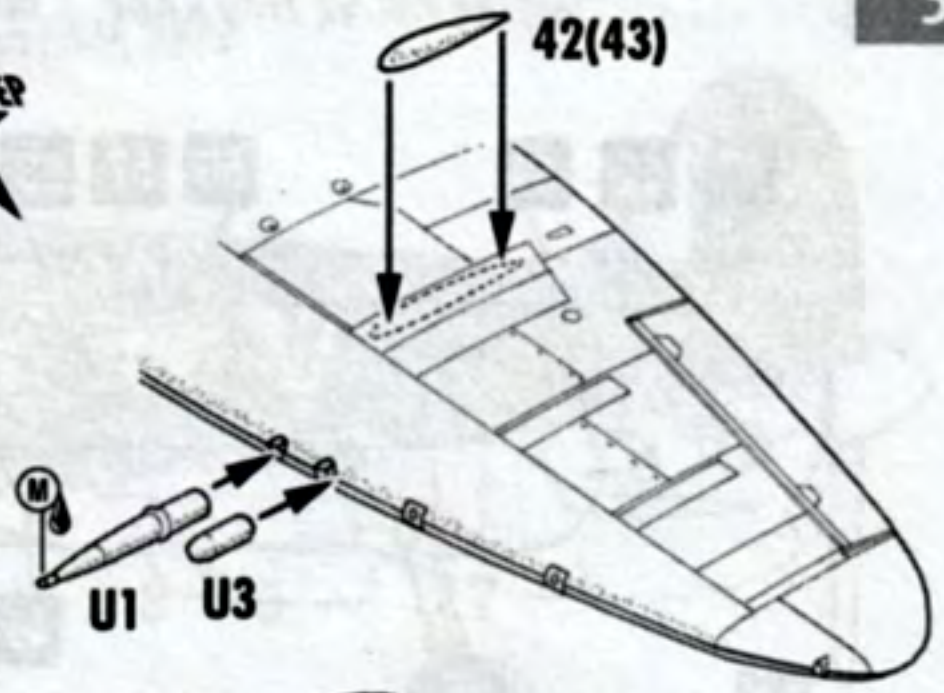
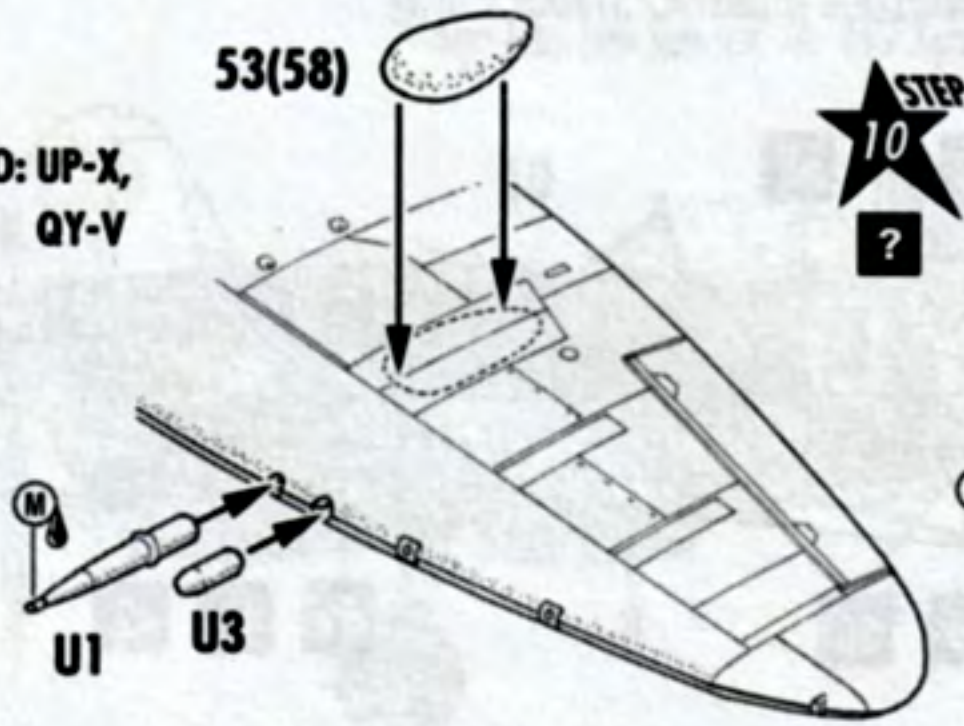

STEP
10
?

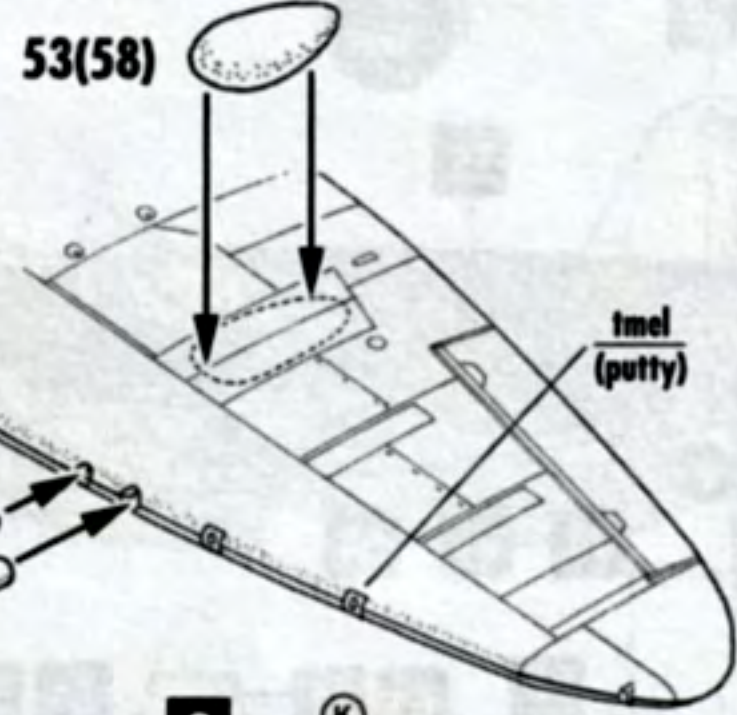

STEP
11

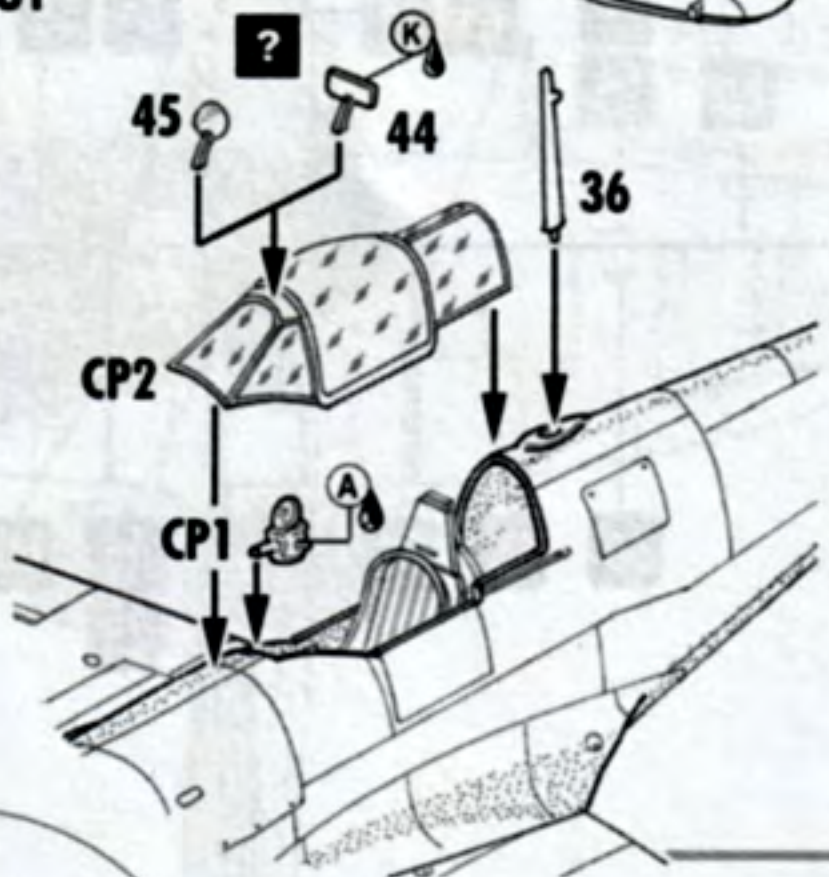
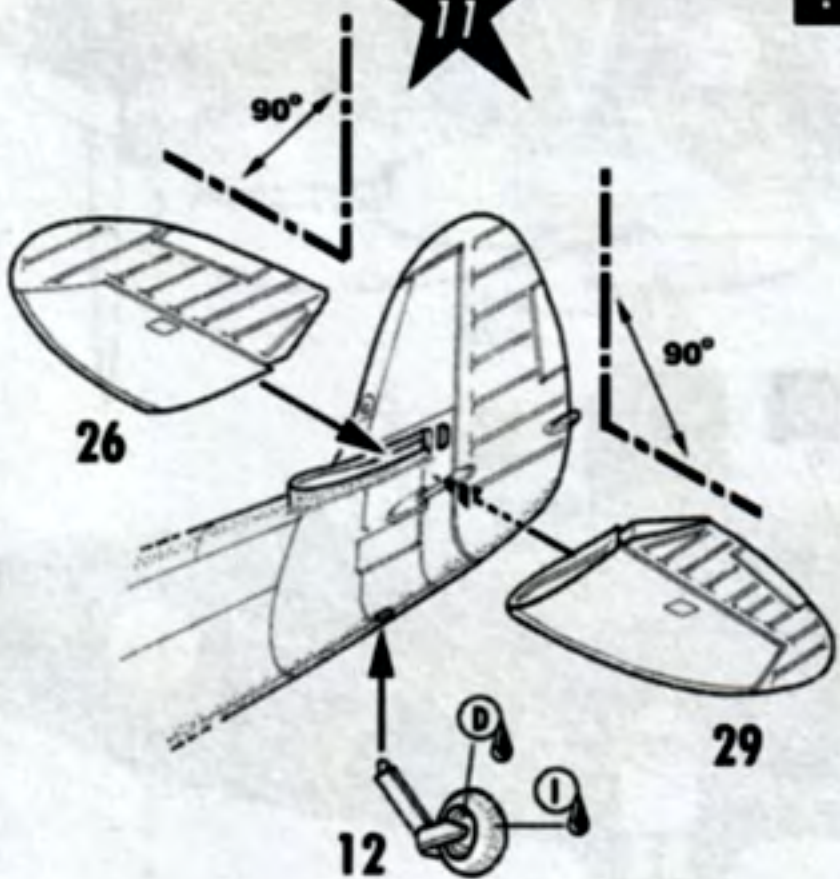

STEP
12
?

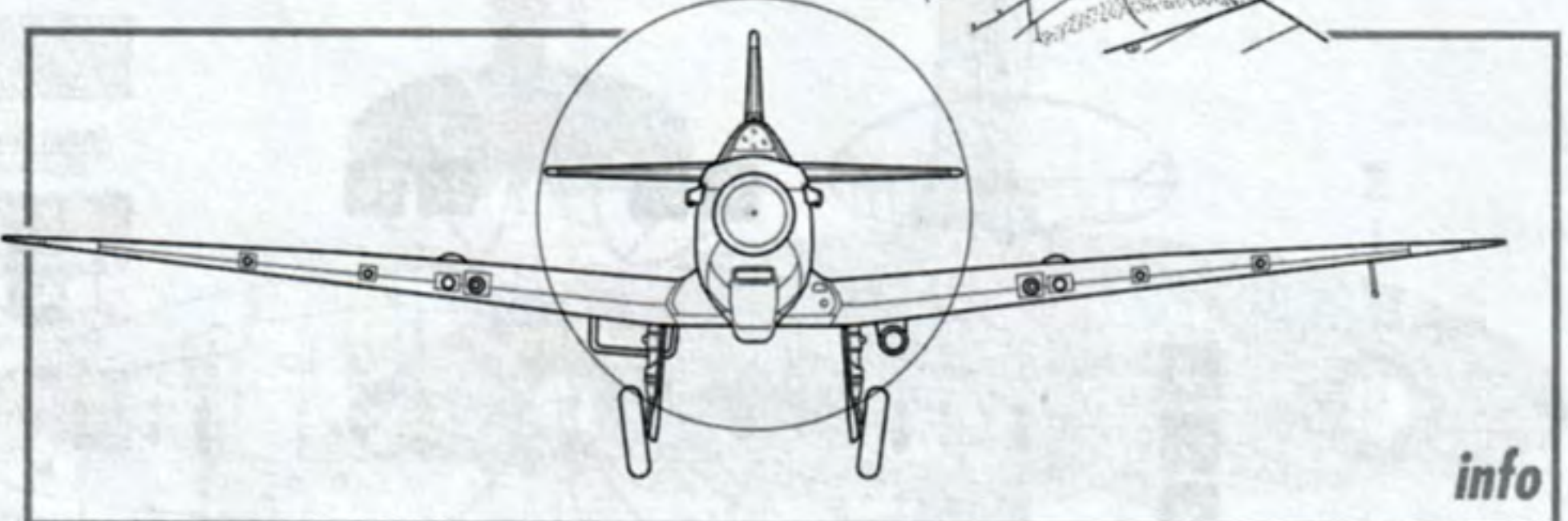

info

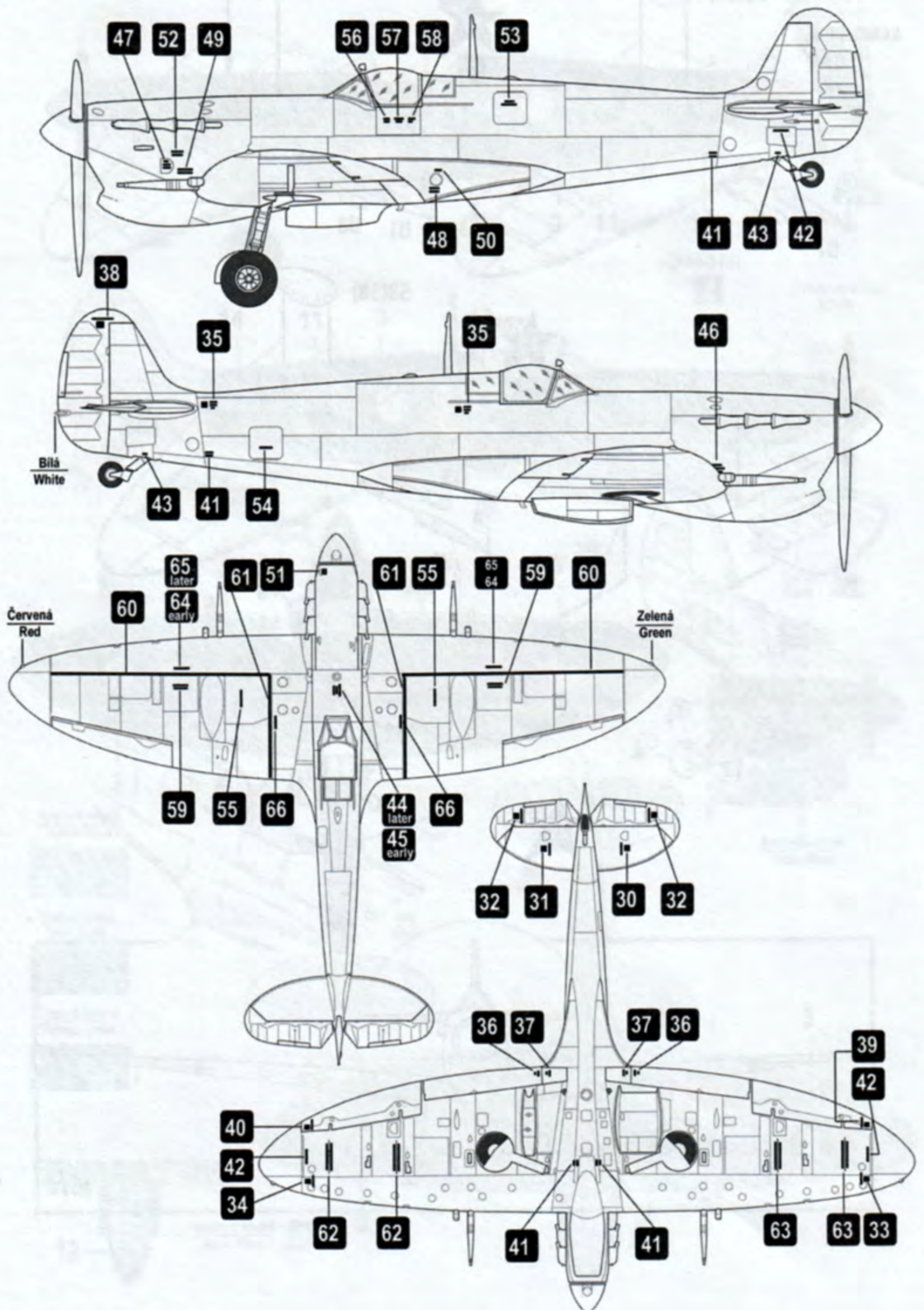

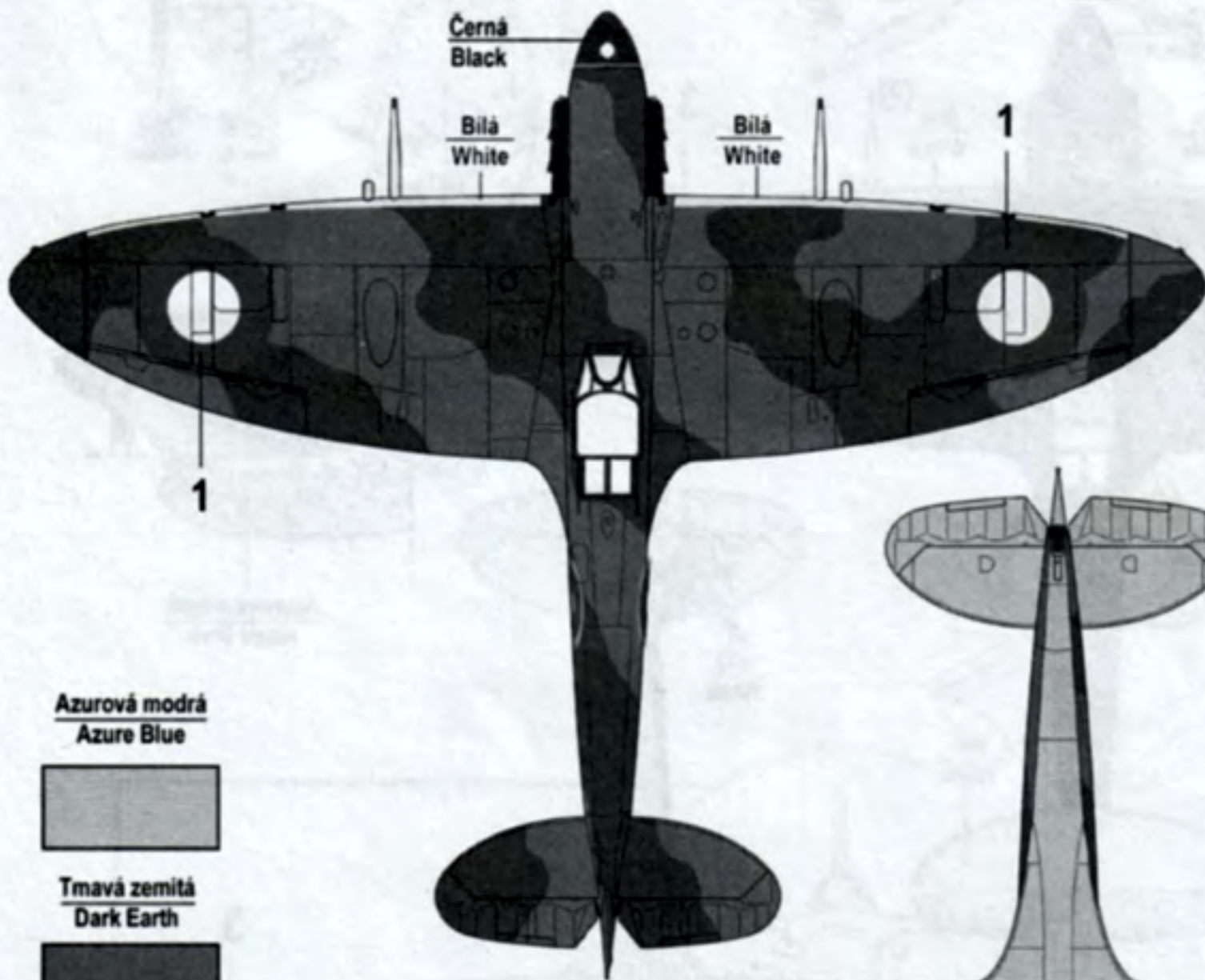
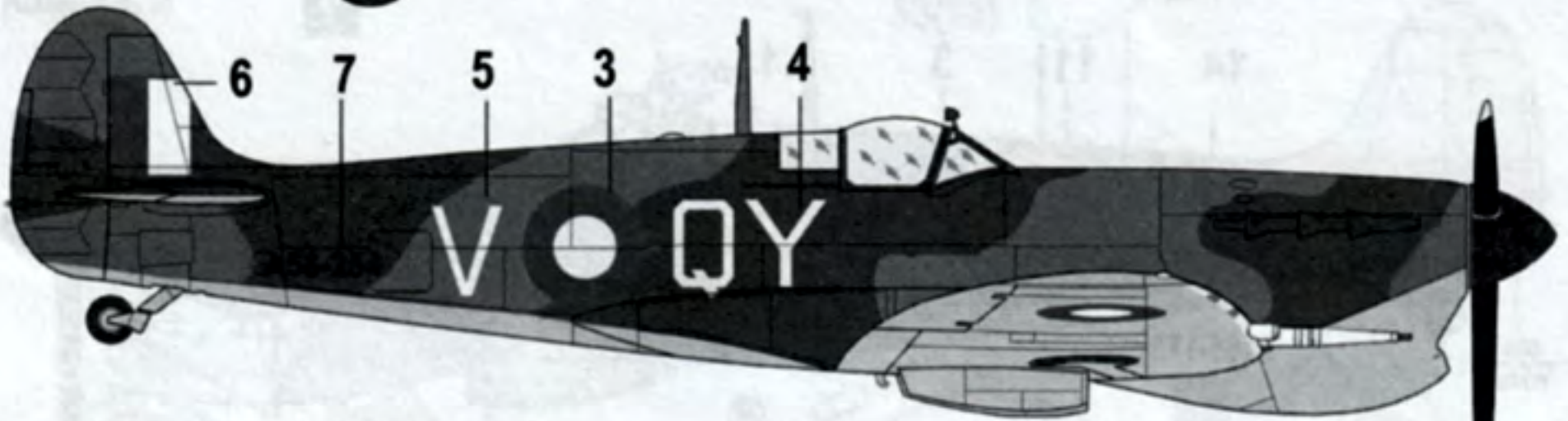
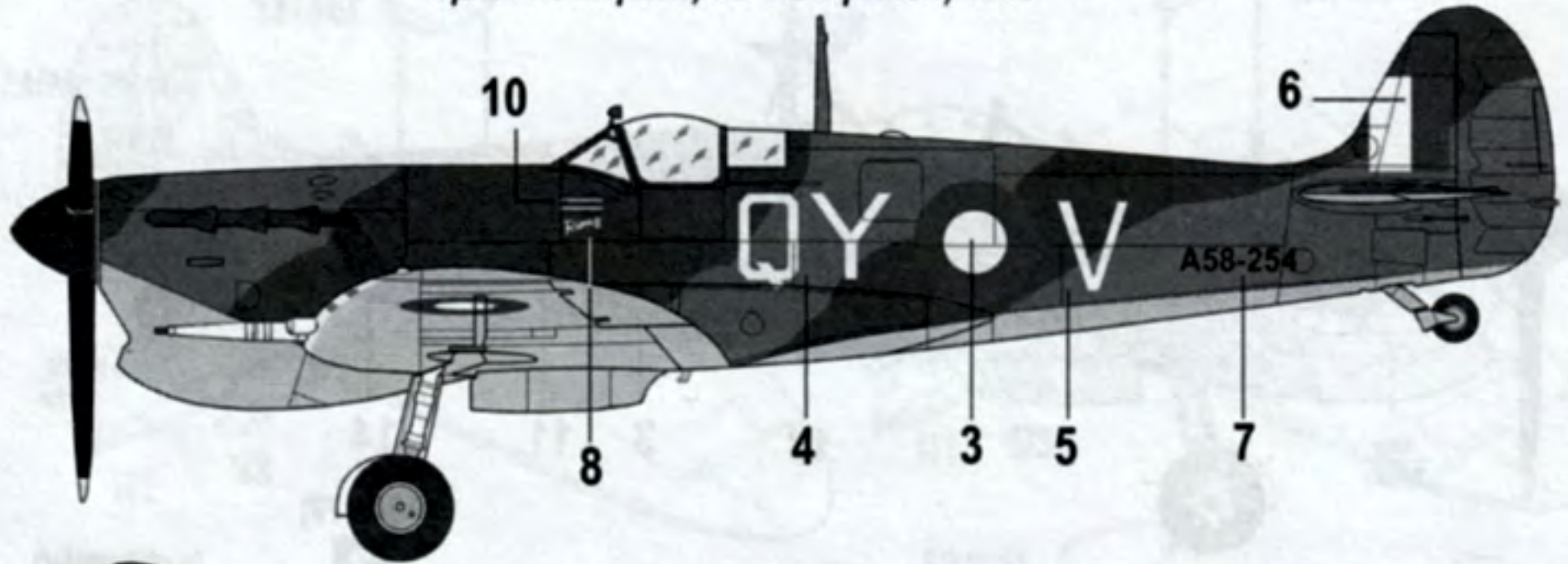

Černá
Black
Žlutá
Yellow
(vrtule/propeller)
ROTOL

Azurová modrá
Azure Blue

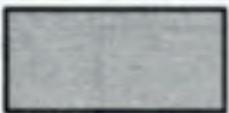

Tmavá zemitá
Dark Earth



Listová zelená
Foliage green

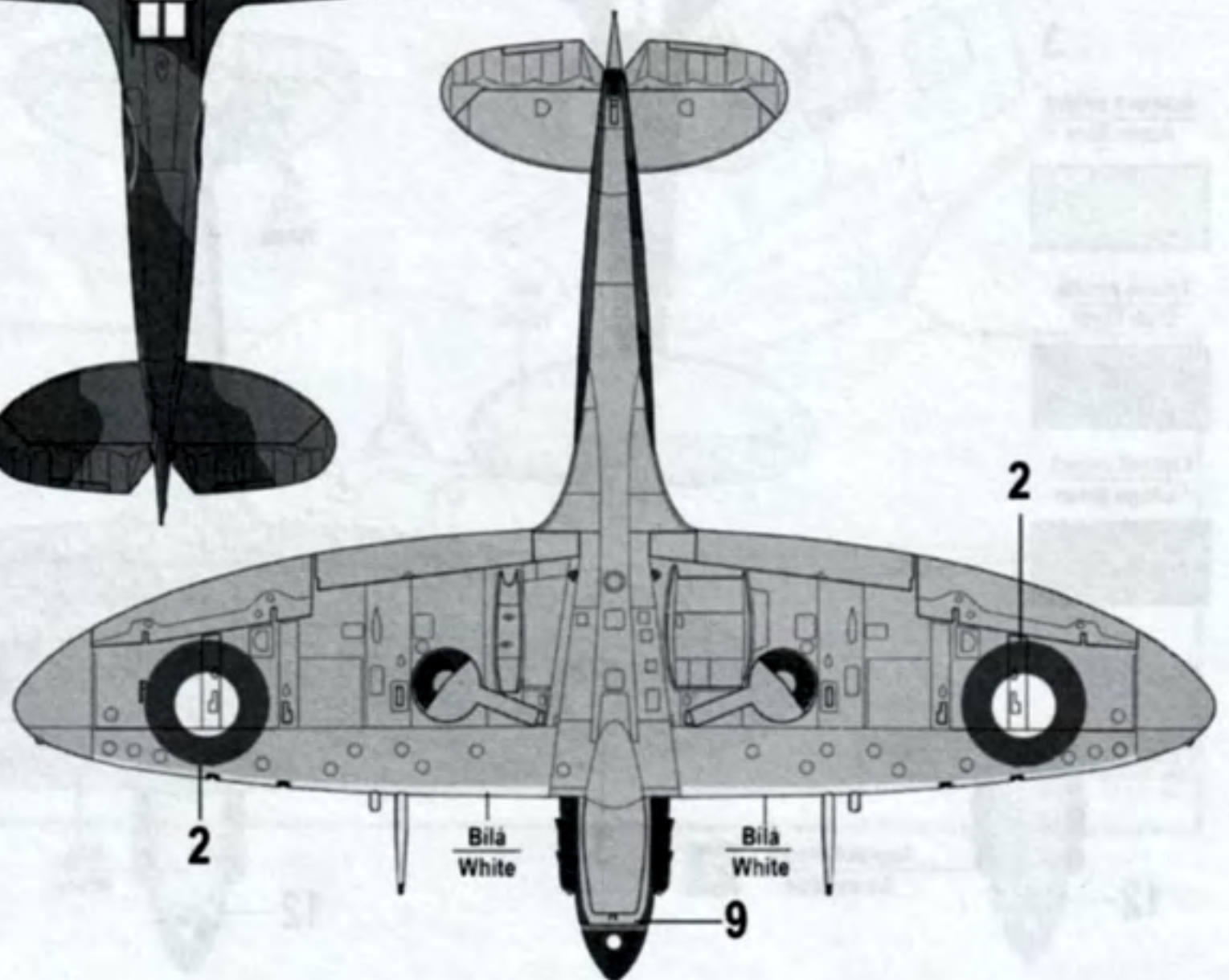
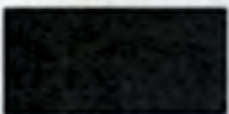

No 79 Sqn RAAF, Los Negros, Admiralty Island, New Guinea, June 1944

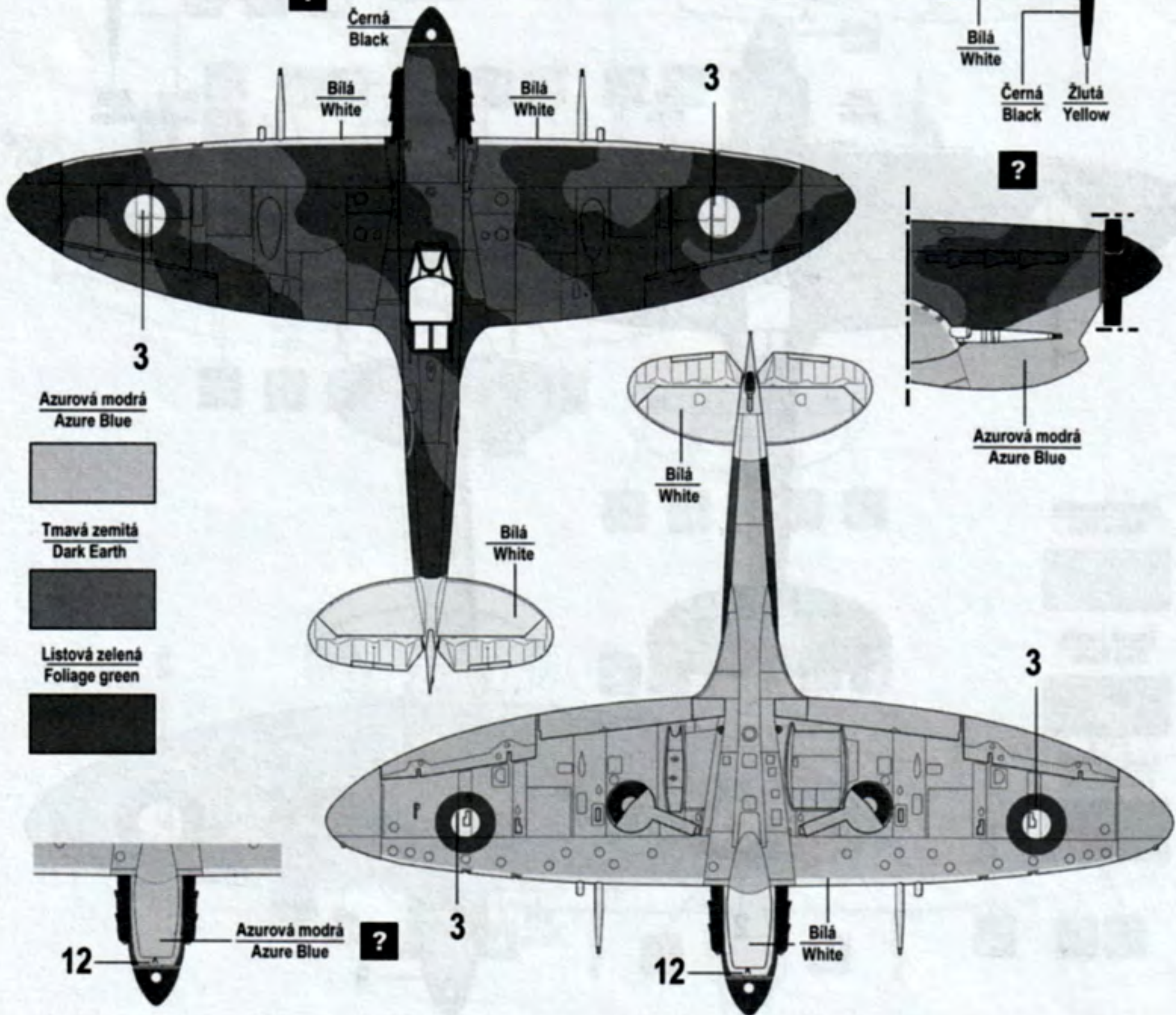
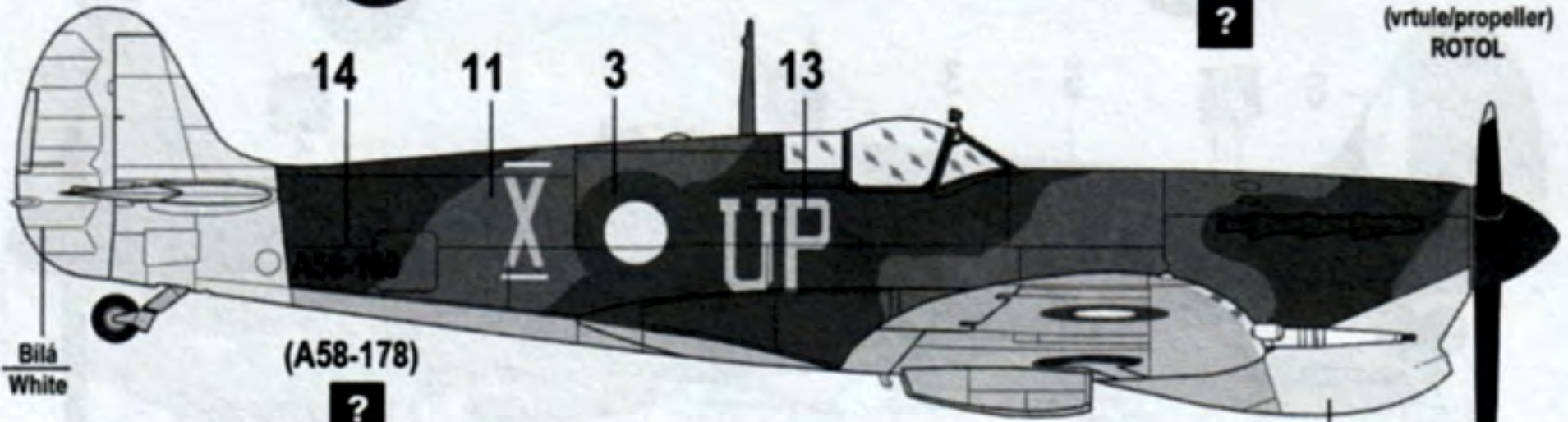
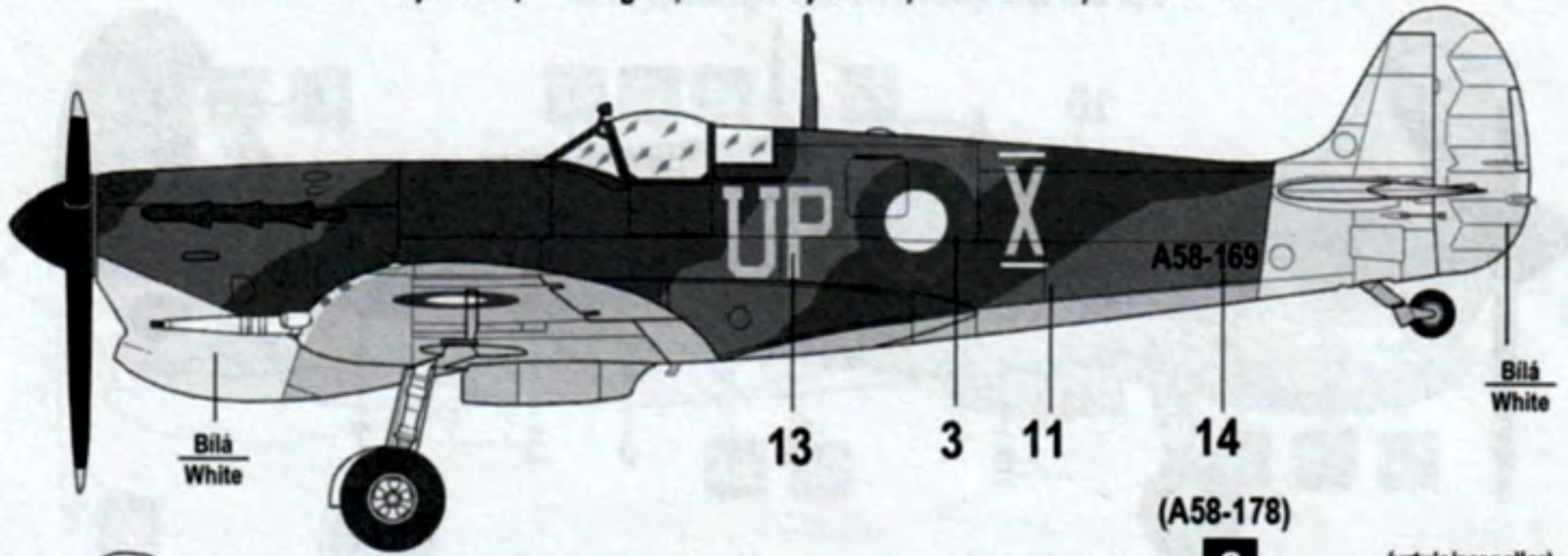

Azurová modrá
Azure Blue

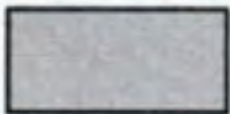

Tmavá zemitá
Dark Earth



Listová zelená
Foliage green



Azurová modrá
Azure Blue

?

Bílá
White

?

Azurová modrá
Azure Blue

3

(vrtule/propeller)
ROTOL

(A58-178)

?

(A58-178)

?

Černá
Black

Bílá
White

Bílá
White

3

Bílá
White

Černá
Black

Žlutá
Yellow

3

Bílá
White

Bílá
White

3

12

12

FO L.F.M. Cronin, No 81 Sqn RAF, Malson Blanche, North Africa, 1942/43

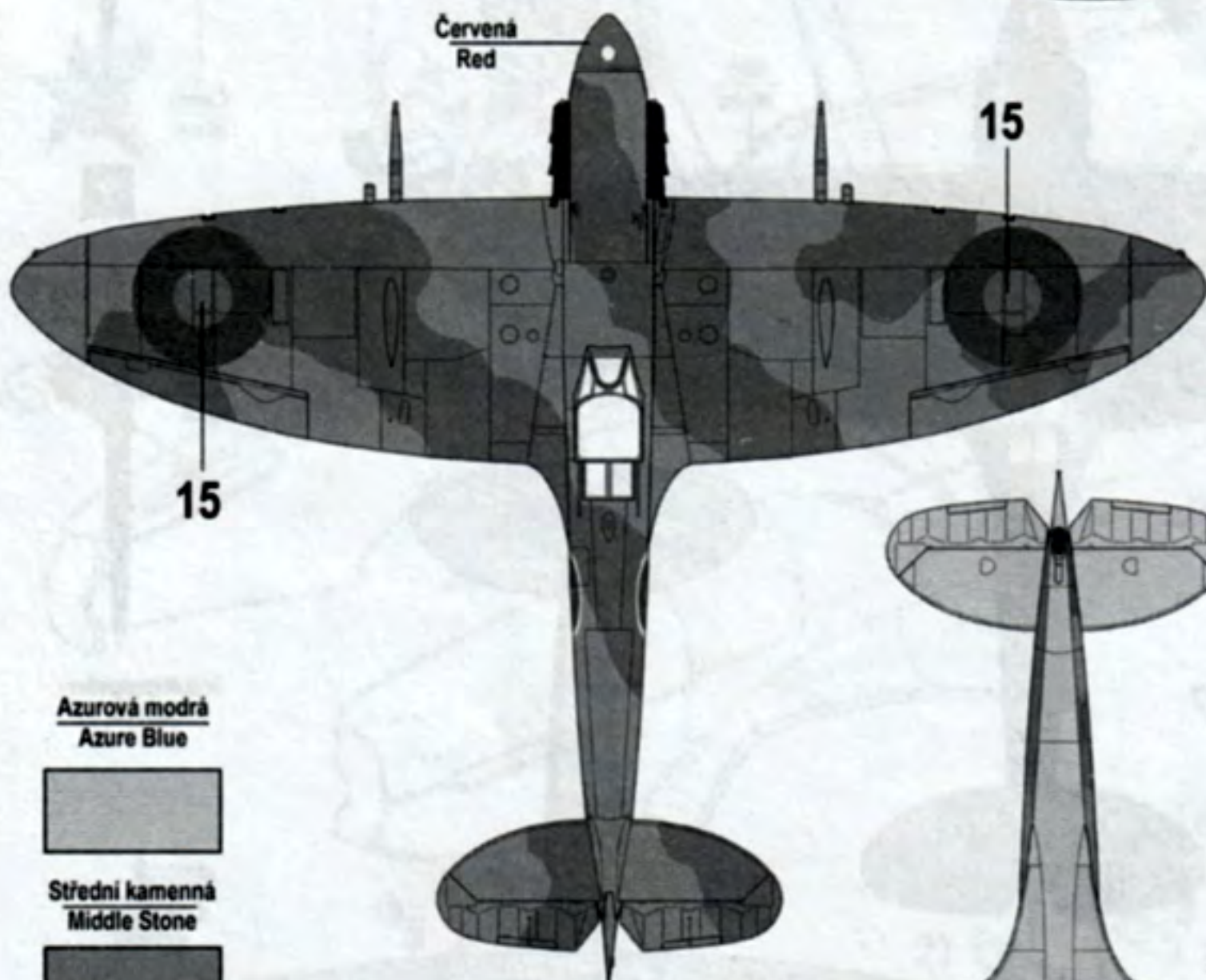
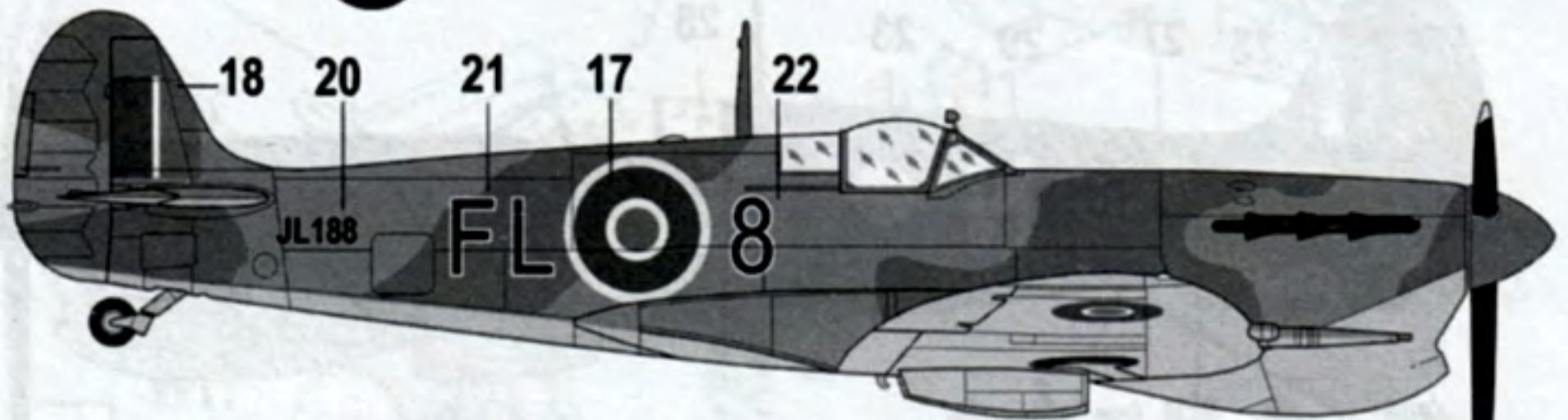
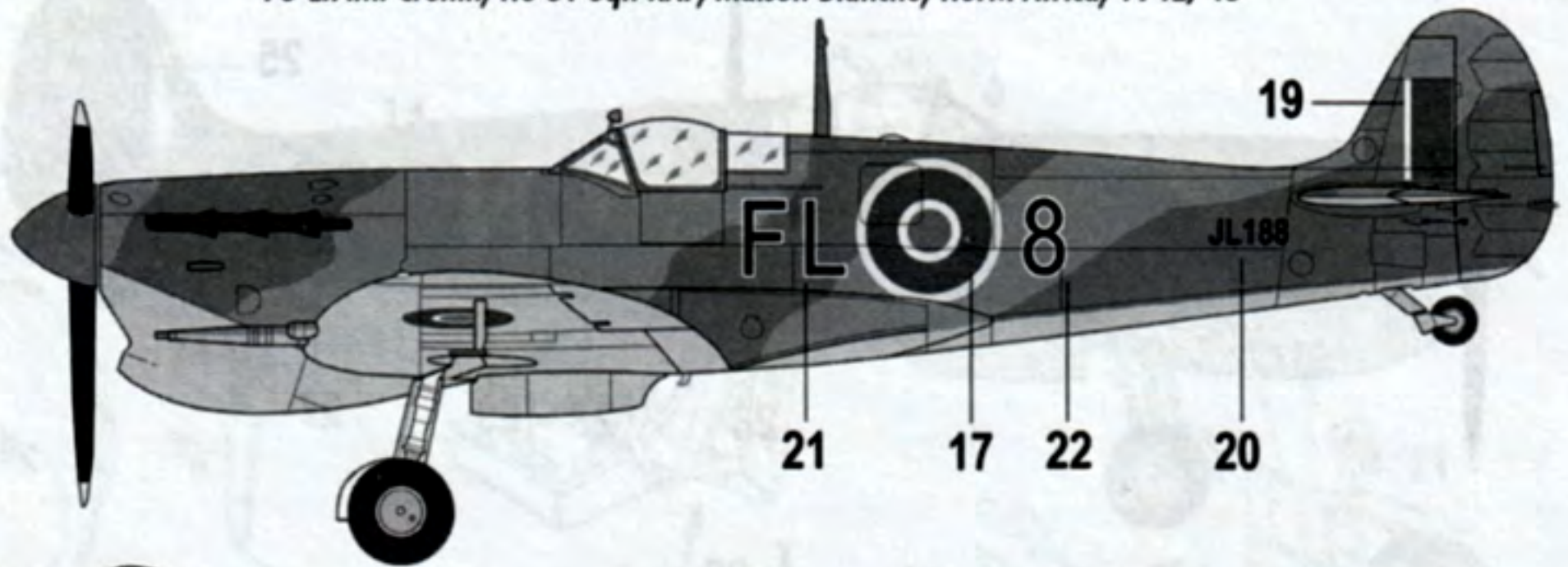

Černá
Black

Žlutá
Yellow

(vrtule/propeller)
ROTOL

Azurová modrá
Azure Blue

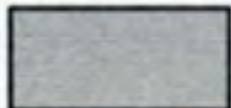

Střední kamenná
Middle Stone

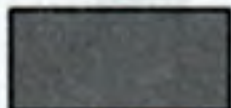

Tmavá zemitá
Dark Earth

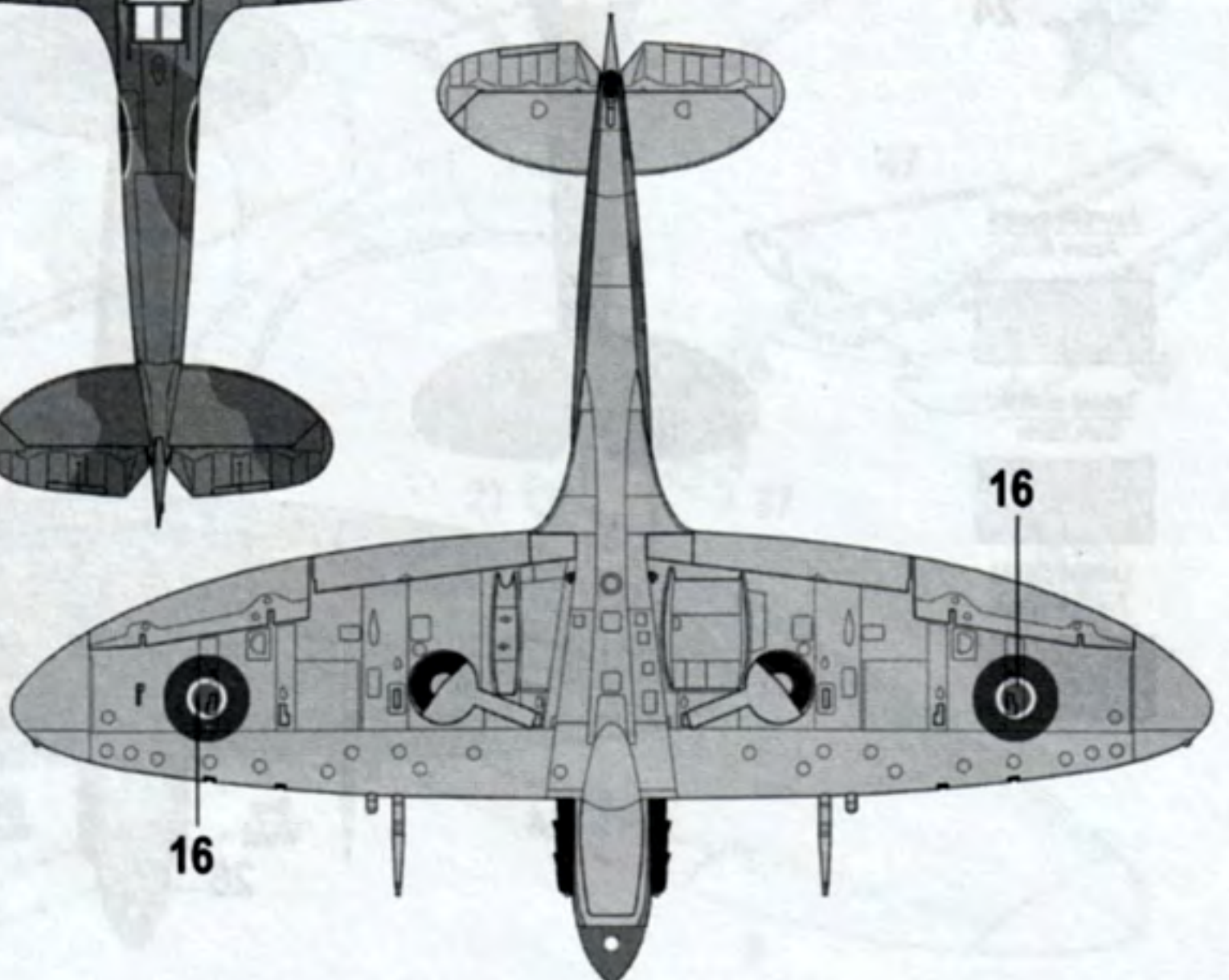

16

16

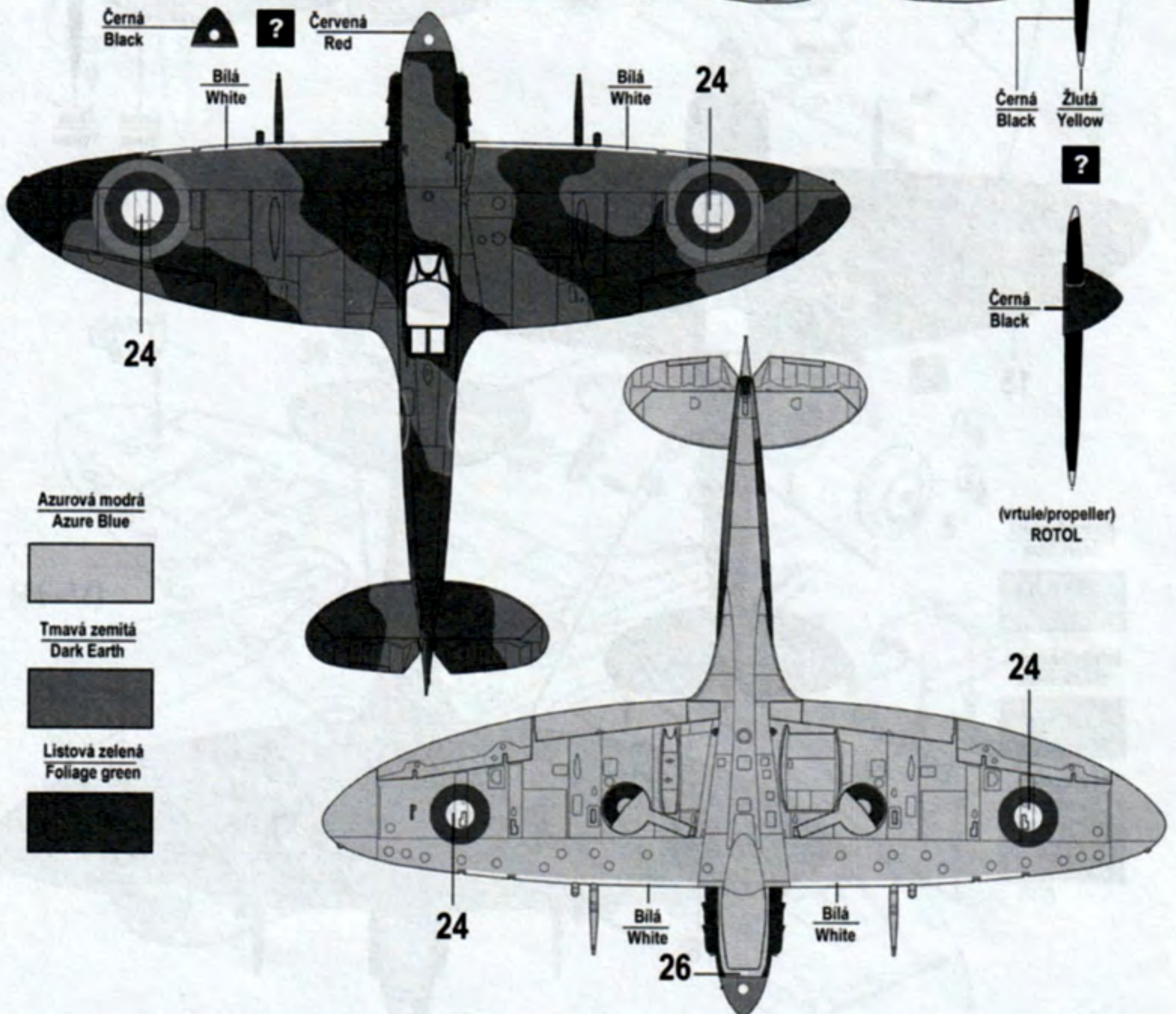
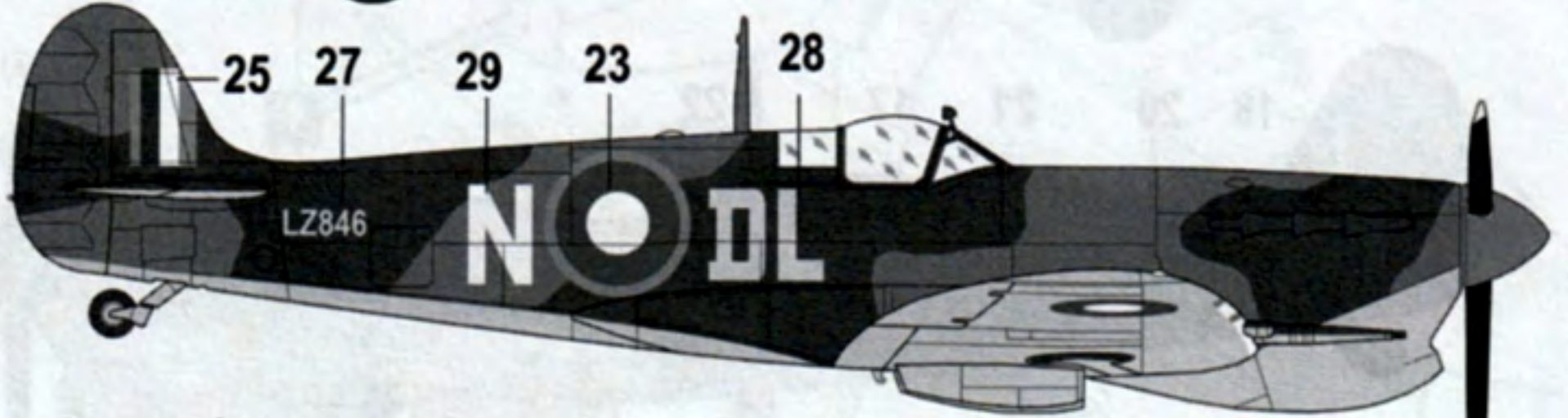
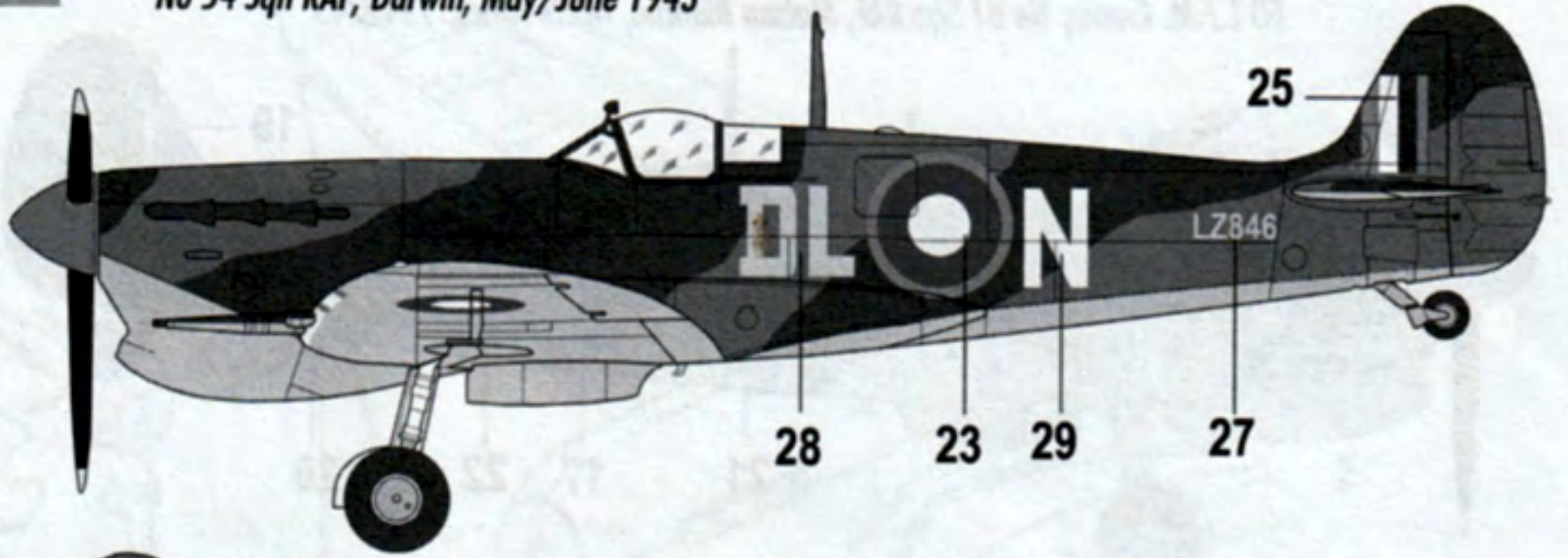

Černá
Black

?

Červená
Red

Bílá
White

Bílá
White

Černá
Black

Žlutá
Yellow

Černá
Black

Azurová modrá
Azure Blue

Tmavá zemitá
Dark Earth

Listová zelená
Foliage green

(vrtule/propeller)
ROTOL

Bílá
White

Bílá
White

Supermarine Spitfire Mk.Vc Trop RAAF



Sqn Ldr. Lou Spence, No 452 Sqn RAAF, 1943

*No 79 Sqn RAAF, Los Negros, Admiralty Island,
New Guinea, June 1944*

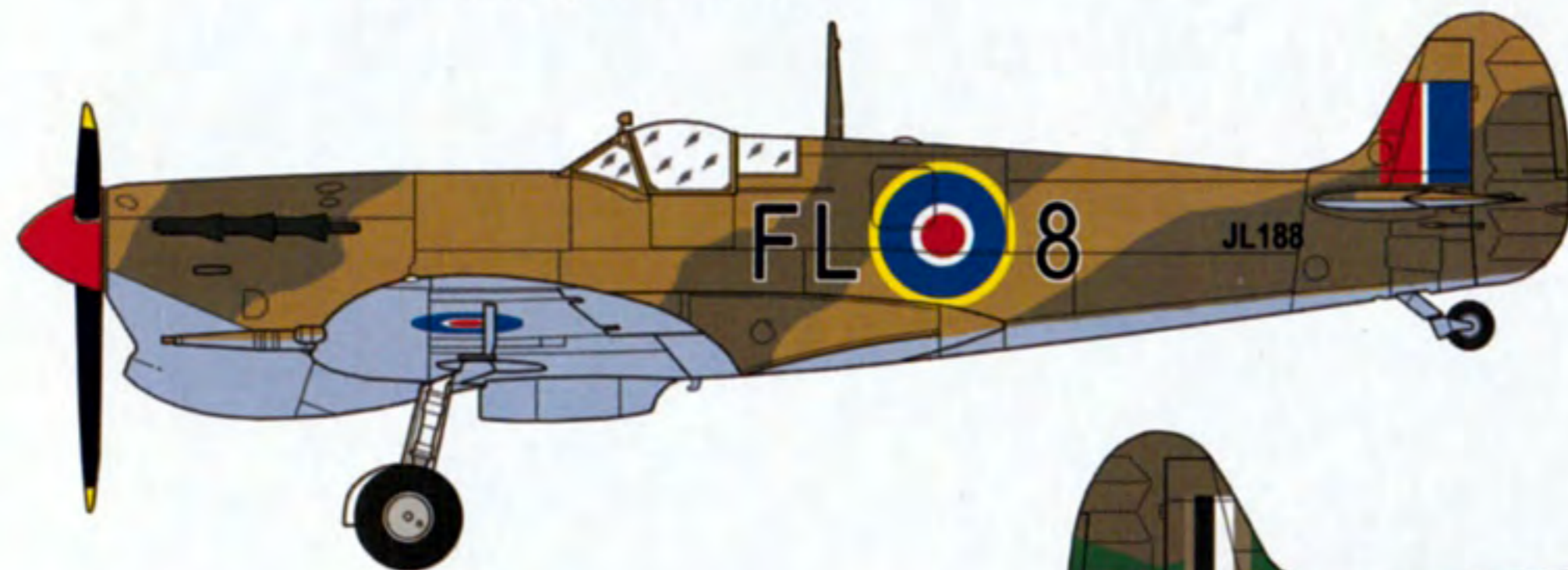

*FO L.F.M. Cronin, No 81 Sqn RAF, Malson Blanche,
North Africa, 1942/43*

No 57 Sqn RAF, Darwin, May/June 1943



SW 72045 (scale 1/72)