

1/48 SCALE

KIT 5402

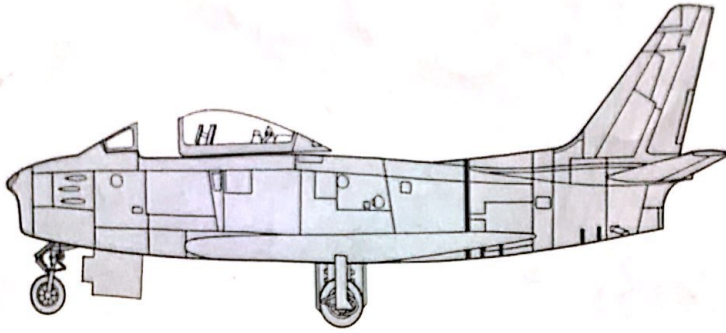

High over the war torn terrain of Korea, aggressive American pilots flying the untried F-86 "Sabre" challenged and defeated the feared MiG-15 in numerous high speed engagements. The phenomenal superiority of the F-86 can be traced not only to the superb abilities of the American pilots, but also to the insight of the designers who created this famous fighter. Utilizing captured German data, North American Aviation engineers developed and refined the technology necessary to create a successful swept wing turbo jet aircraft. The outbreak of war in Korea accelerated the development of new, improved "Sabre" variants and established it as the world's most advanced operational jet fighter. More than thirty U.S. Air Force pilots became aces and succeeded in clearing the Korean skies of intruding MiGs. The sleek F-86 "Sabres" that successfully gained air superiority for U.N. forces in Korea, also thrust the fledgling U.S. Air Force into the jet age and eventually served as first line fighters in countless air forces throughout the world.

Your model depicts an F-86F-10 "Sabre" assigned to the 51st Fighter Interceptor Wing. This aircraft is fitted with the "6-3" extended leading edges that are designed to improve high speed maneuverability and reduce drag. Six .50 caliber machine guns are mounted in the nose, and two jettisonable fuel tanks are fitted beneath the wings to increase the range of the aircraft. This variant of the F-86 had a cruising speed of 513 miles per hour that enabled the pilot to remain in the air for more than two hours. When completed, you will have a fine replica of the famous F-86 "MiG Killer."

PLEASE READ CAREFULLY BEFORE YOU BEGIN

Read the instructions and study the assembly drawings to become familiar with all the parts. Refer to the PAINTING and DECAL directions on rear page.

Each illustration in the assembly procedure indicates color to be used and where the paint should be applied.

Refer to airplane drawings on rear page for painting schemes.

Each "tree" of plastic parts is molded with identifying numbers, appearing on the part or on a tab next to the corresponding part. In the assembly instructions, identifying numbers are indicated. This method makes it easy for you to locate parts during the assembly.

Do not detach parts from the trees until you are ready to use them. After cutting or breaking off the required parts, trim away any excess bits of plastic. Use a small sharp knife, such as a modeling

knife, available at your hobby counter. Check the fit of each part before you cement it in place.

Keep in mind the importance of not rushing the assembly of your model and avoid the use of excessive amounts of cement. All plastic cements contain solvents that dissolve plastic in order to form a weld between the cemented parts. Too much cement can soften and distort the plastic, spoiling your model's appearance. When applying the cement to small or confined areas, use cement on the end of a toothpick instead of the tube nozzle to better regulate the amount of cement being applied.

For better paint and decal adhesion, it is advisable to wash the plastic parts trees in a mild detergent solution. Rinse and let dry. After washing, handle the parts carefully to avoid skin-oil which may affect the adhesion.

MONOGRAM MODELS, INC. Morton Grove, Ill.

Copyright © 1976

All rights reserved.

Made in U.S.A.

5402-0202

F-86 SABRE JET

MONOGRAM

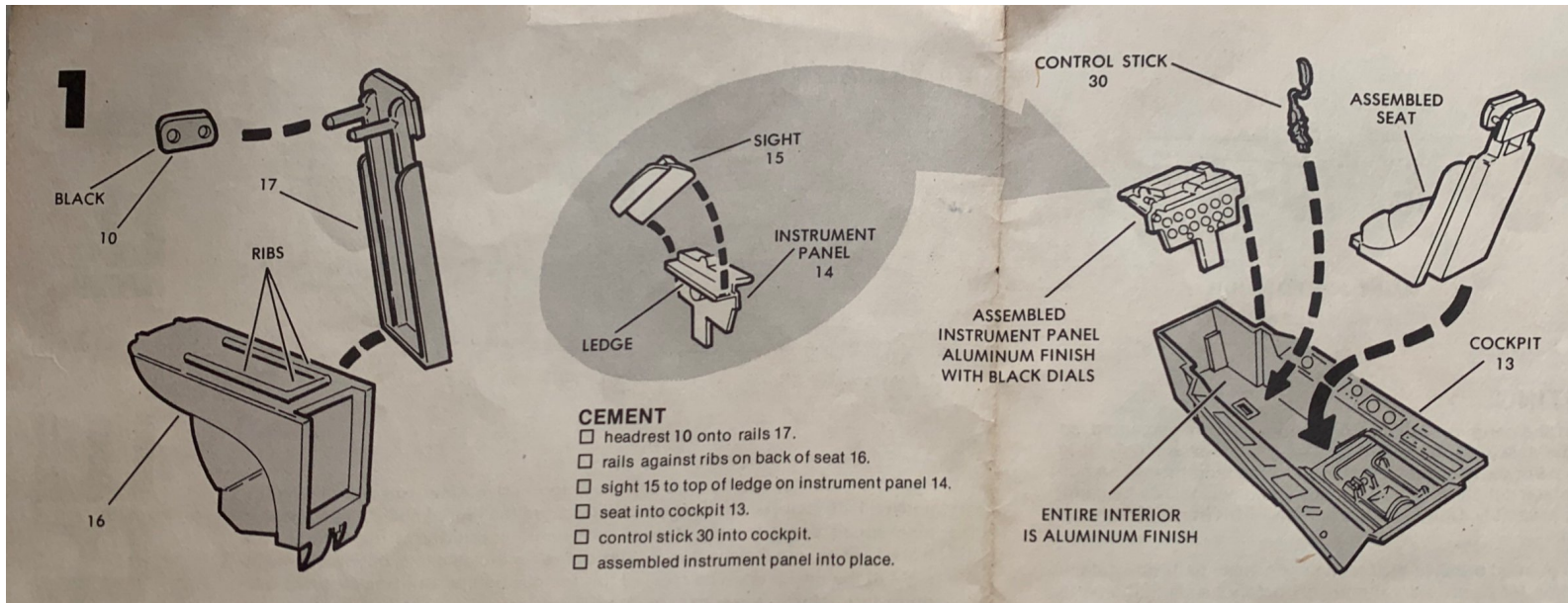

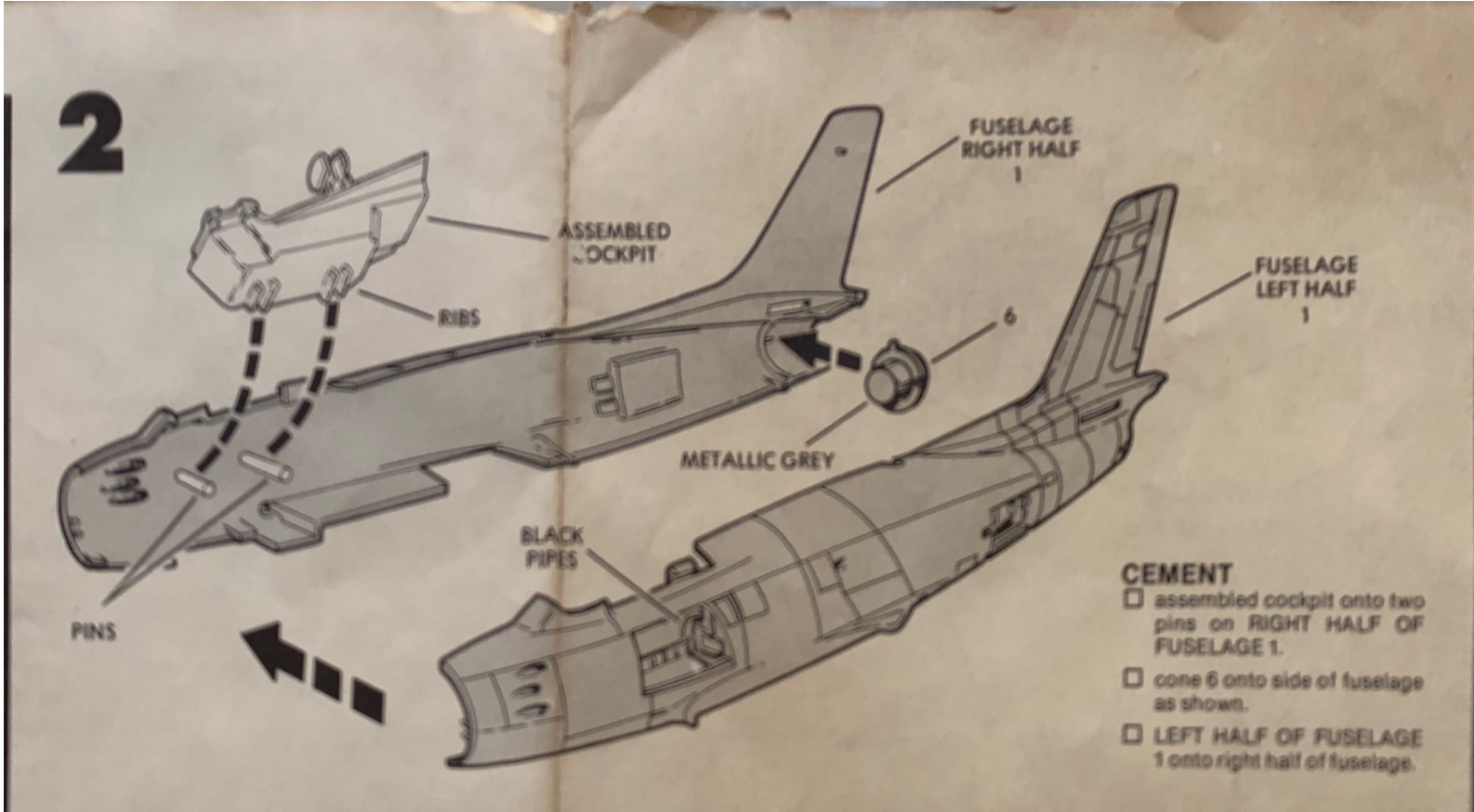

3

- Clean out FOUR holes in wing bottom 3 as indicated.
- Place (do not cement) pins on flaps 11R and 11L into slots in wing bottom as shown.
- Cement wing tops 4R and 4L to wing bottom. BE EXTREMELY CAREFUL NOT TO APPLY CEMENT NEAR THE SLOTS OR THE PINS ON THE FLAPS. Check the fit of the wings BEFORE applying cement.
- When cement has dried completely, the flaps can be actuated.

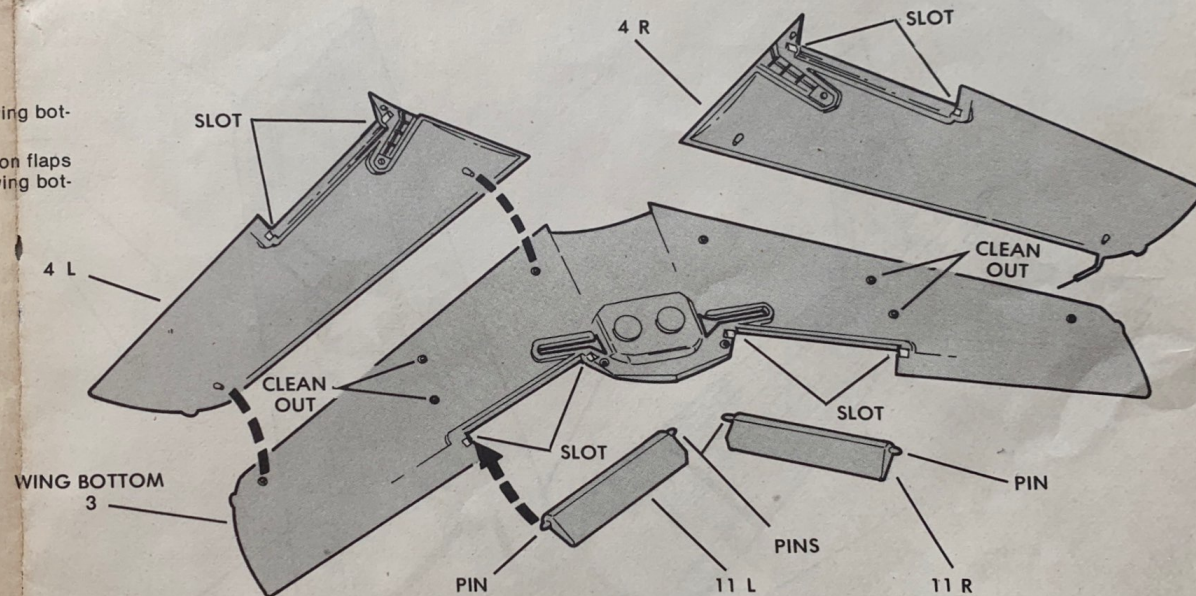

4

- Carefully follow the application instructions on the back of the decal sheet.
- Apply decals into the wheel wells in wing bottom. SEE SMALL ILLUSTRATION.
- Slip (do not cement) wheel 35 onto strut 32L.
- Carefully apply a SMALL amount of cement into the HOLE in brake drum 36.
- Press brake drum onto axle on strut. Wheels will revolve.
- Next, cement cover 21L to strut, then cement strut into wing bottom.
- Cement door 22L onto stops in opening as shown. SEE SMALL ILLUSTRATION ON REAR PAGE FOR DOOR POSITION.
- Repeat for strut 32R, cover 21R, door 22R and wheel 35.

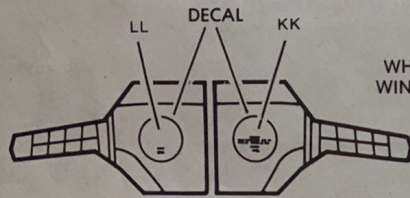

SMALL ILLUSTRATION

WHEEL WELL
WING BOTTOM

HOLE IN WING
FOR CLEAR SUPPORT PIECE
TO BE ADDED
AFTER COMPLETING STEP 12

NOTE:
ALL DOOR INTERIORS
AND WHEEL WELLS
ARE ALUMINUM FINISH

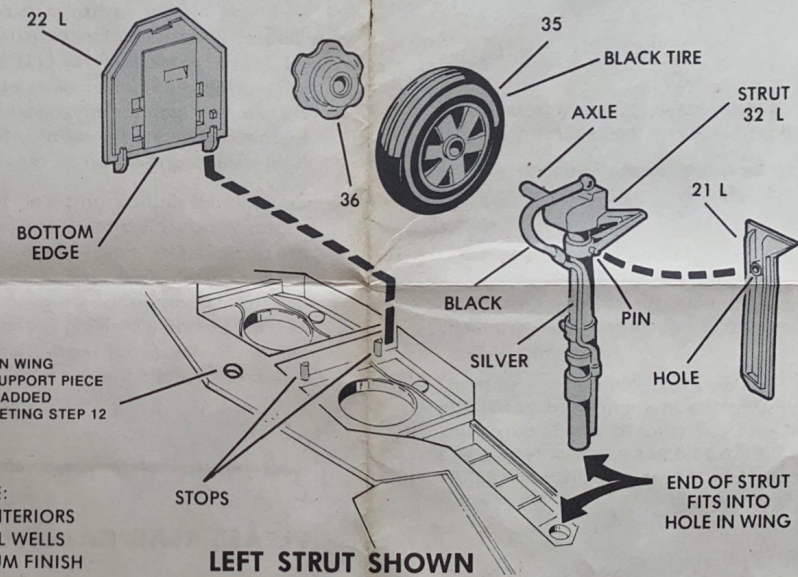

LEFT STRUT SHOWN

5

TRUT
2 L

ASSEMBLED
WING

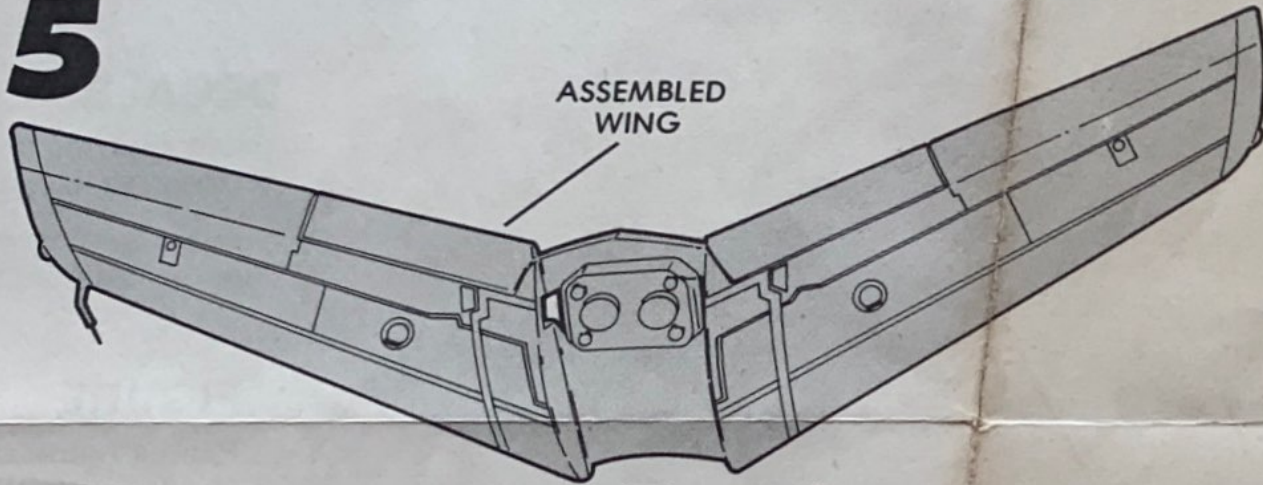

FUSELAGE

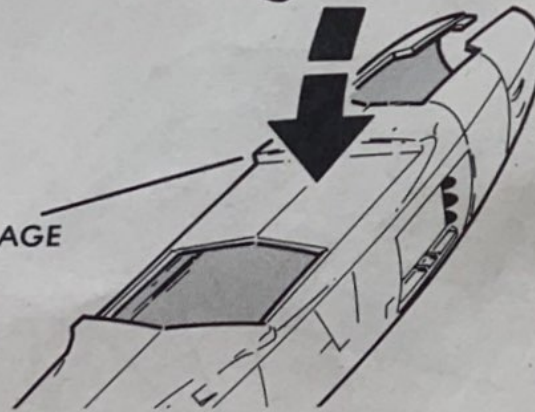

- Place (do not cement) assembled wing into fuselage as shown.
- Remove wing, apply cement to areas where wing touched fuselage.
- Cement wing into place.

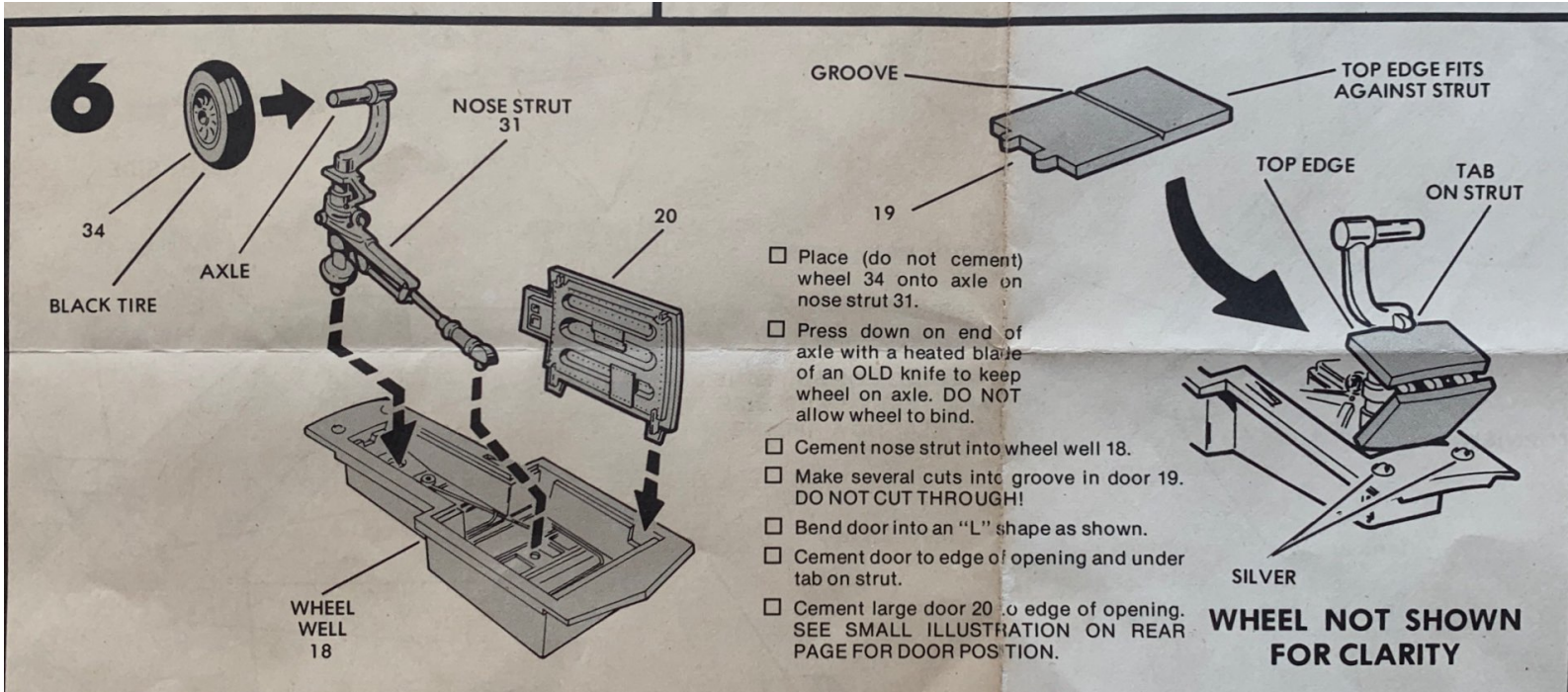

6

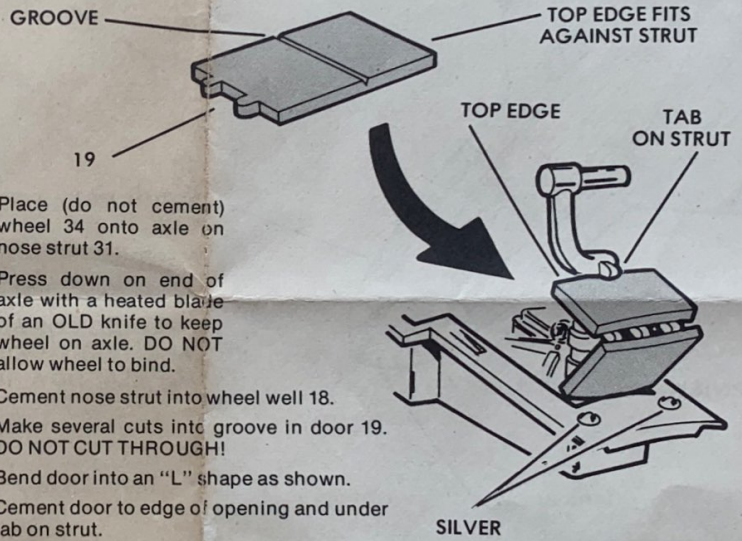
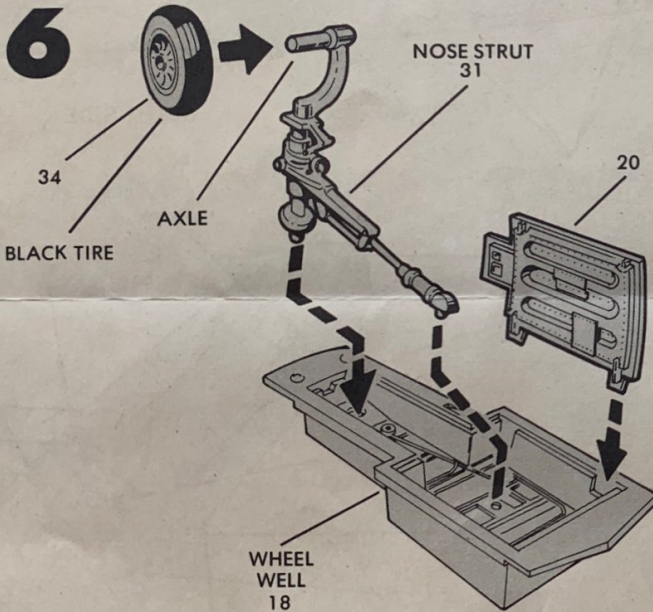

- Place (do not cement) wheel 34 onto axle on nose strut 31.
- Press down on end of axle with a heated blade of an OLD knife to keep wheel on axle. DO NOT allow wheel to bind.
- Cement nose strut into wheel well 18.
- Make several cuts into groove in door 19. DO NOT CUT THROUGH!
- Bend door into an "L" shape as shown.
- Cement door to edge of opening and under tab on strut.
- Cement large door 20 to edge of opening. SEE SMALL ILLUSTRATION ON REAR PAGE FOR DOOR POSITION.

WHEEL NOT SHOWN FOR CLARITY

7

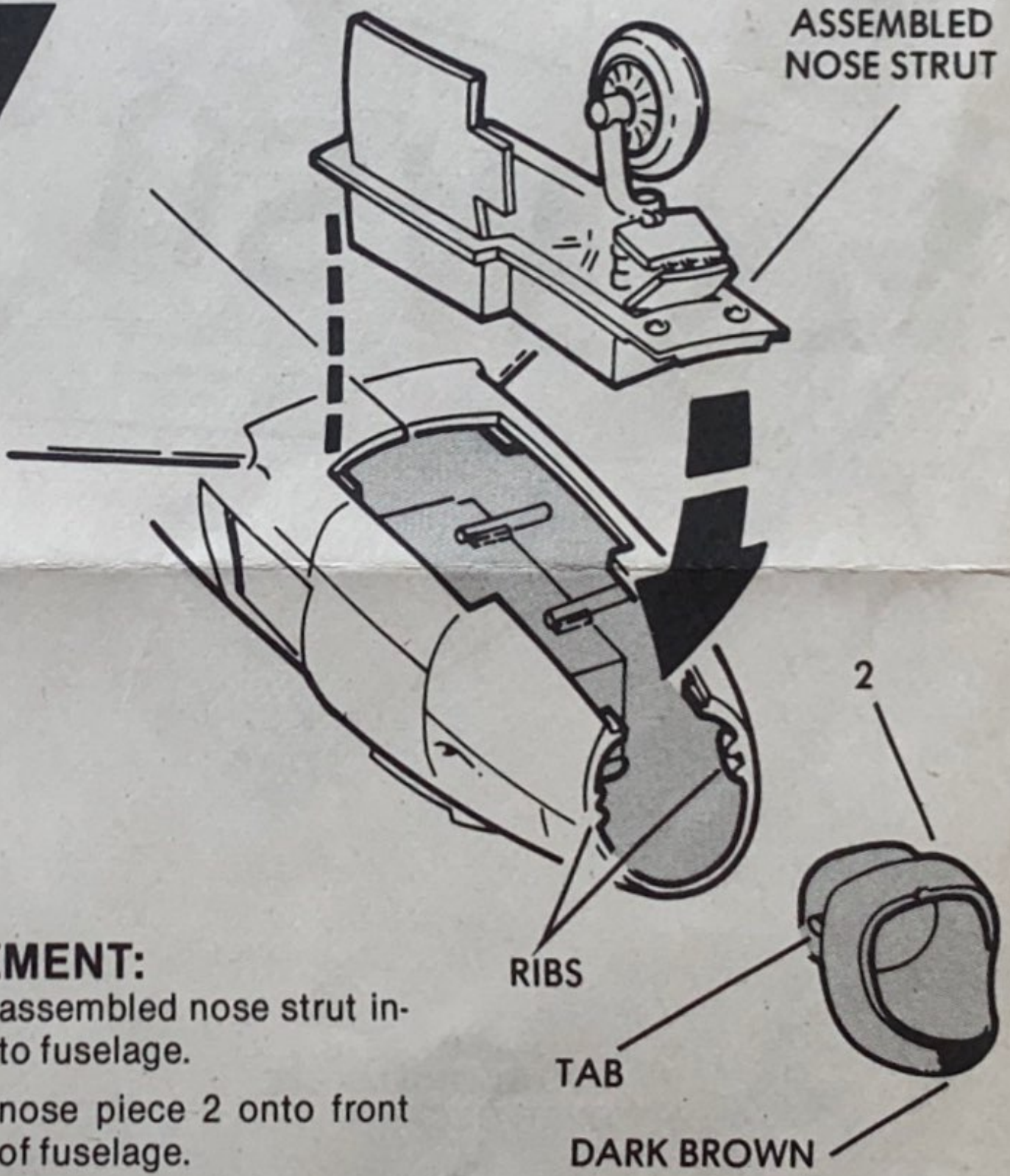

CEMENT:

- assembled nose strut into fuselage.
- nose piece 2 onto front of fuselage.

8

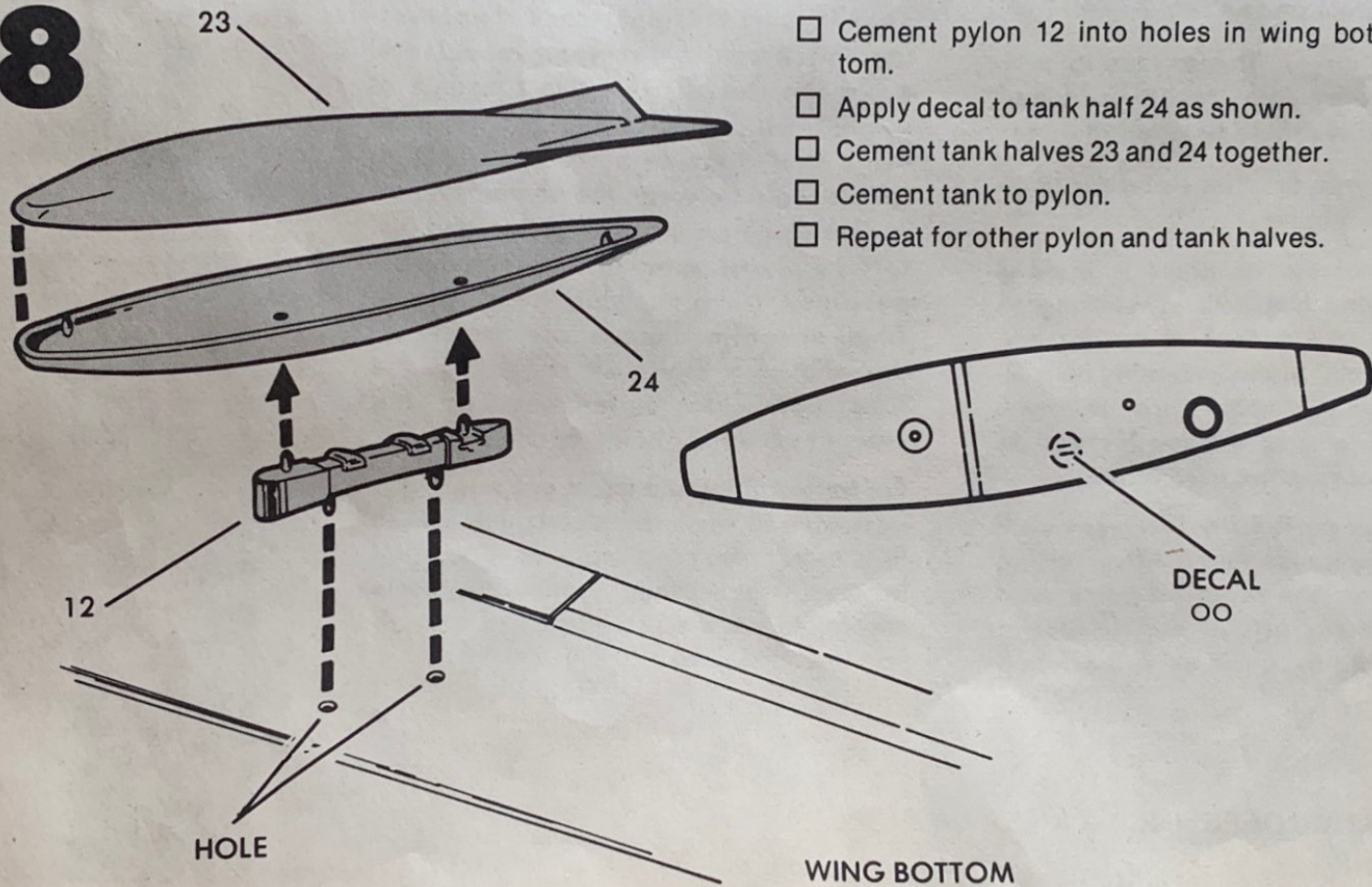

- Cement pylon 12 into holes in wing bottom.
- Apply decal to tank half 24 as shown.
- Cement tank halves 23 and 24 together.
- Cement tank to pylon.
- Repeat for other pylon and tank halves.

9

- BEFORE cementing the clear pieces into position, paint the raised lines. Refer to PAINTING directions for canopies.
- Cement clear cover into canopy frame 25.
- Slide (do not cement) canopy frame under clips on fuselage. Tabs on frame fit INTO fuselage opening.
- Carefully cement canopy onto canopy frame.
- Cement windshield to fuselage.
- When cement has dried, canopy may be slid open or closed.

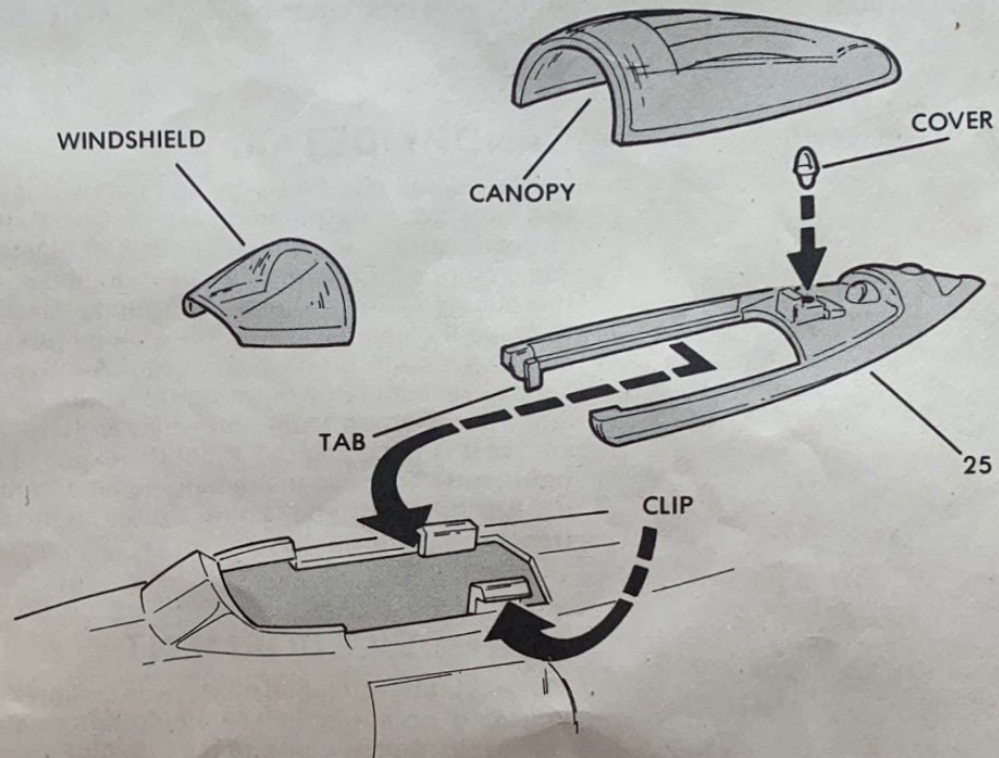

10

- Cement guns 9 into opening on side of fuselage.
- Door 8 may be cemented in place or placed (not cemented) to top of wing or display surface.

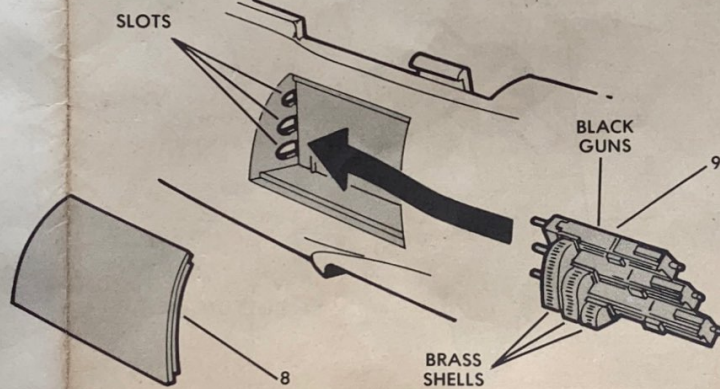

11

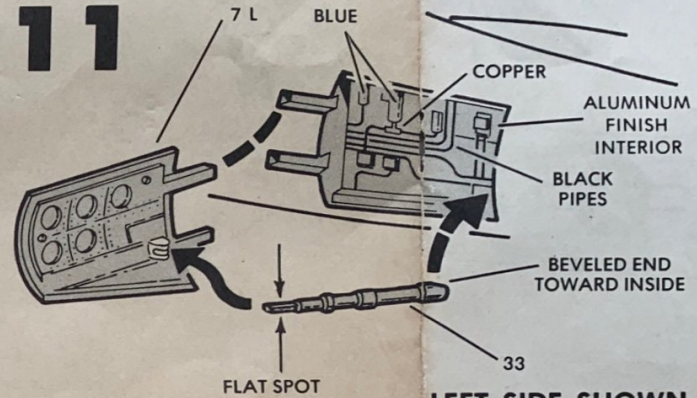

LEFT SIDE SHOWN

- BEFORE proceeding with this assembly—PLACE (do not cement) air brake 7L and 7R into openings in fuselage. Apply tape to hold doors.
- Apply decal as indicated on rear page.
- After the decal has dried slightly—use a sharp modeling knife to cut the decal along both sides of the air brake
- Cement both air brakes 7L and 7R and pins 33 into place shown.

12

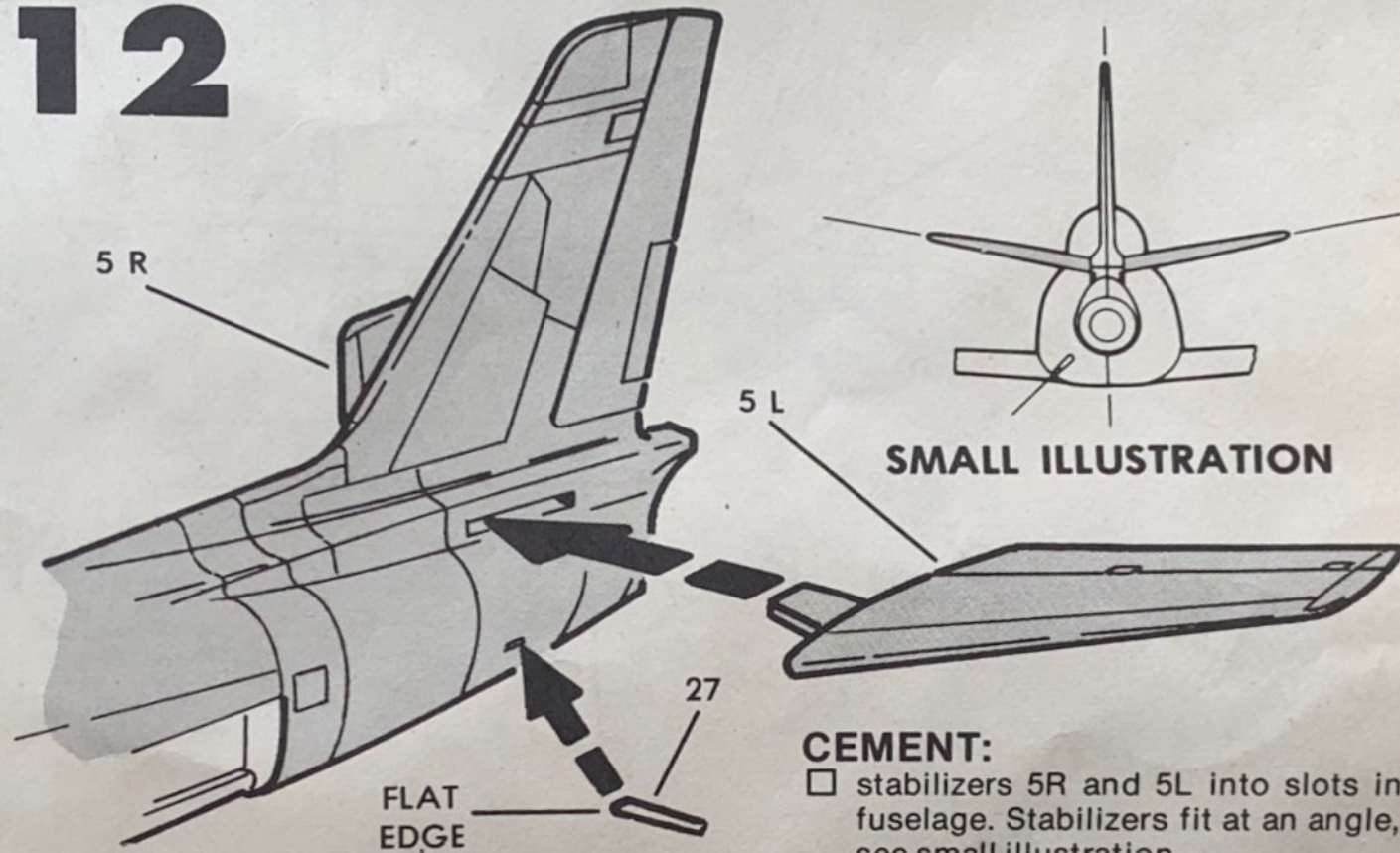

Cement CLEAR support piece into hole in bottom of wing. This will keep model in proper position on the three wheels.

CEMENT:

- stabilizers 5R and 5L into slots in fuselage. Stabilizers fit at an angle, see small illustration.
- fuel drain 27 between raised lines on fuselage as shown. Drain fits on an angle, see small illustration.

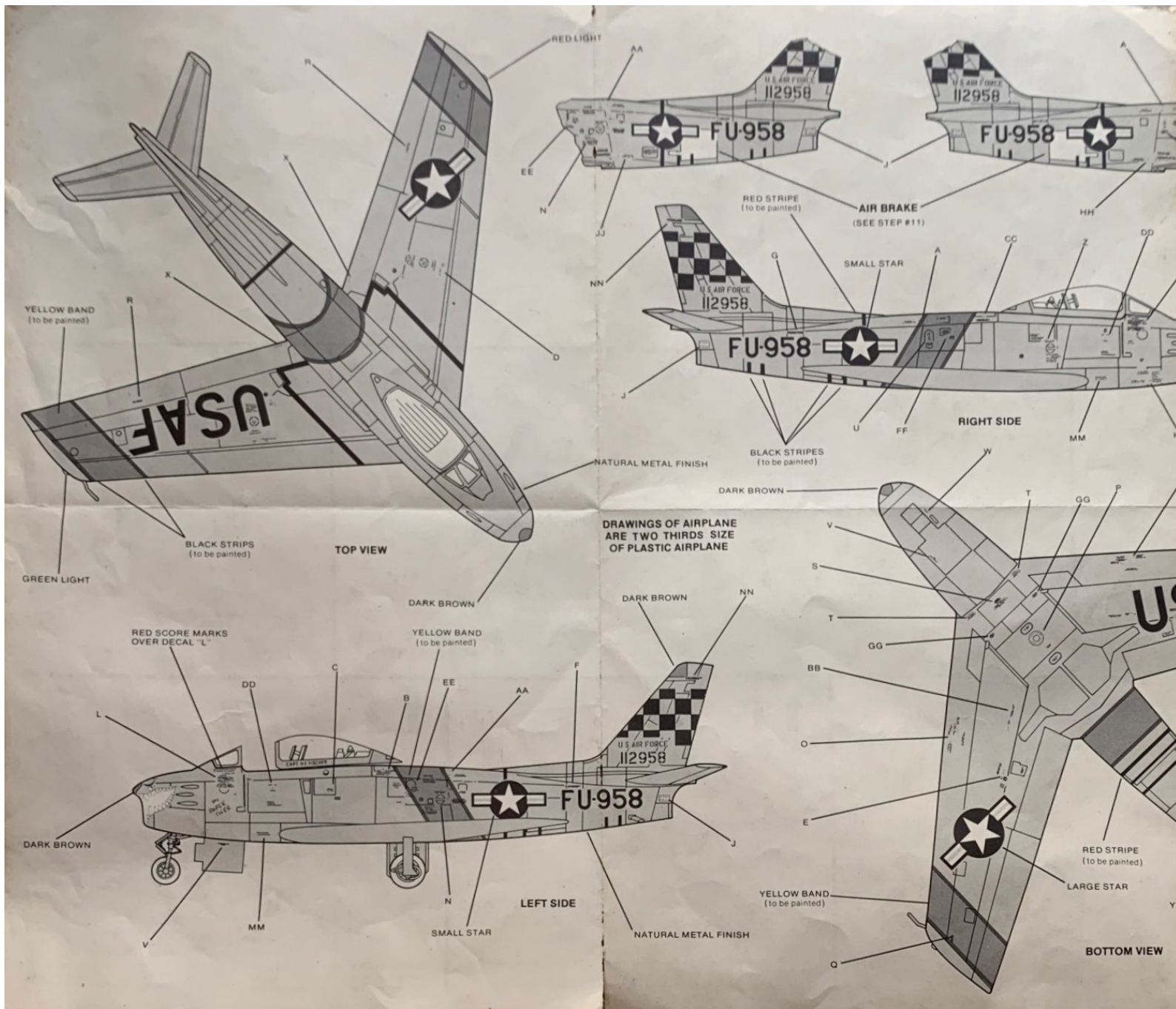

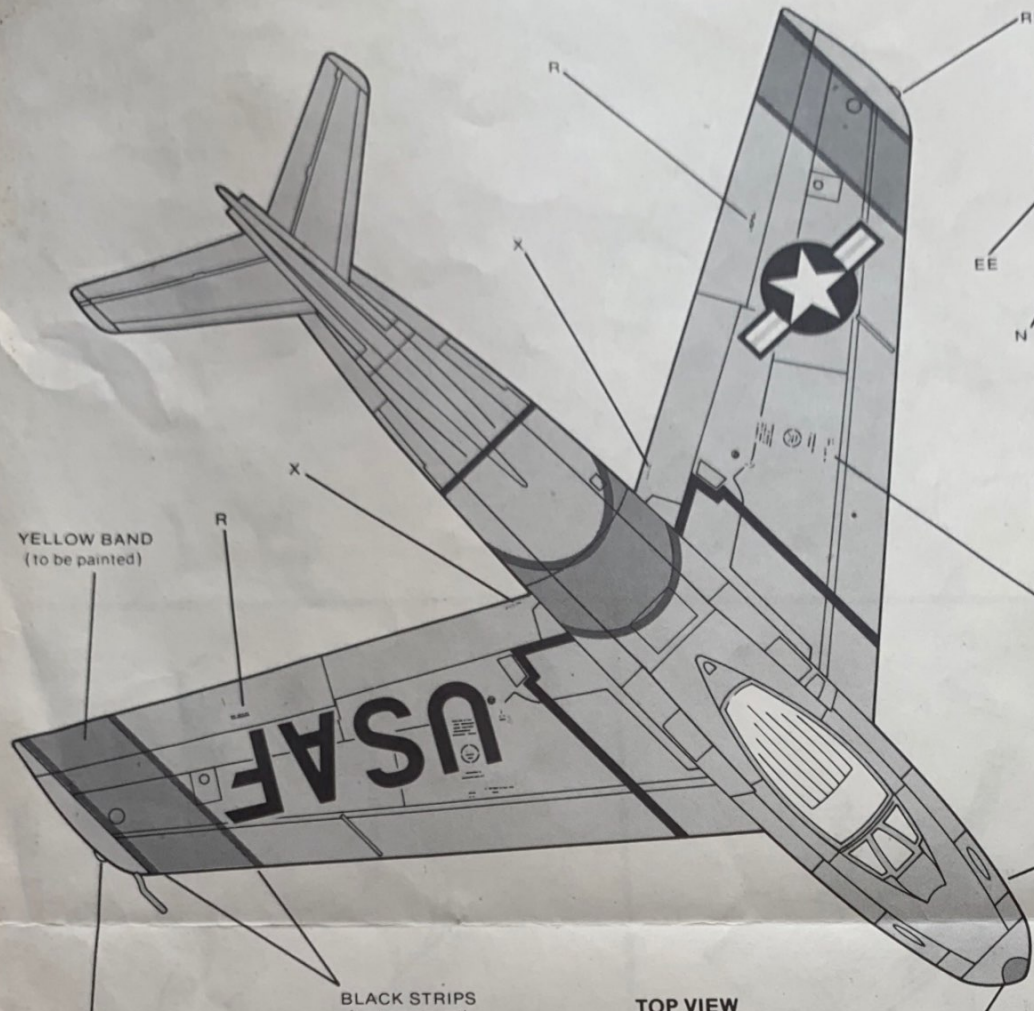

TOP VIEW

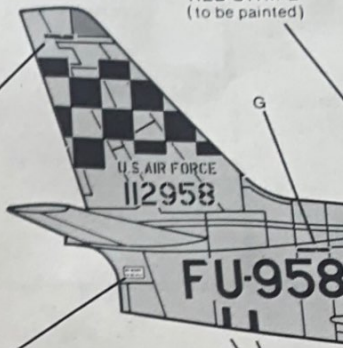
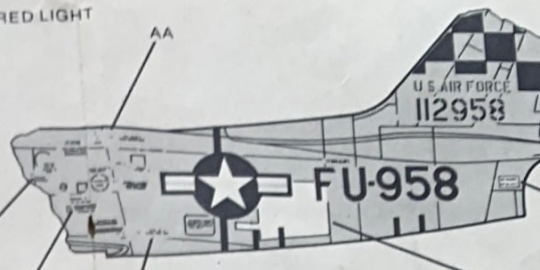

NATURAL METAL FINISH

BLACK STRIPE (to be painted)

DARK BROWN

DRAWINGS OF AIRPLANE ARE TWO THIRDS SIZE OF PLASTIC AIRPLANE

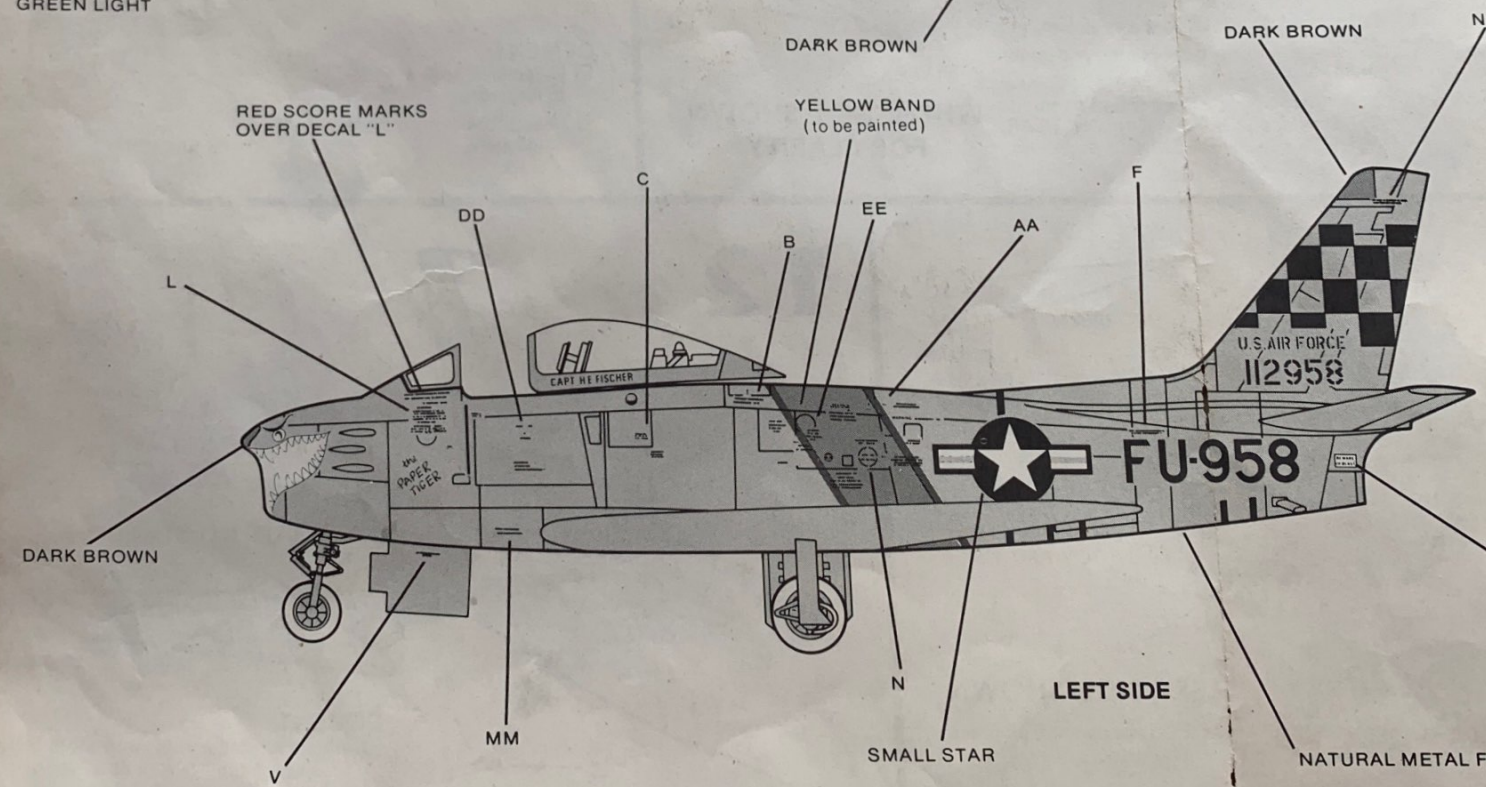

LEFT SIDE

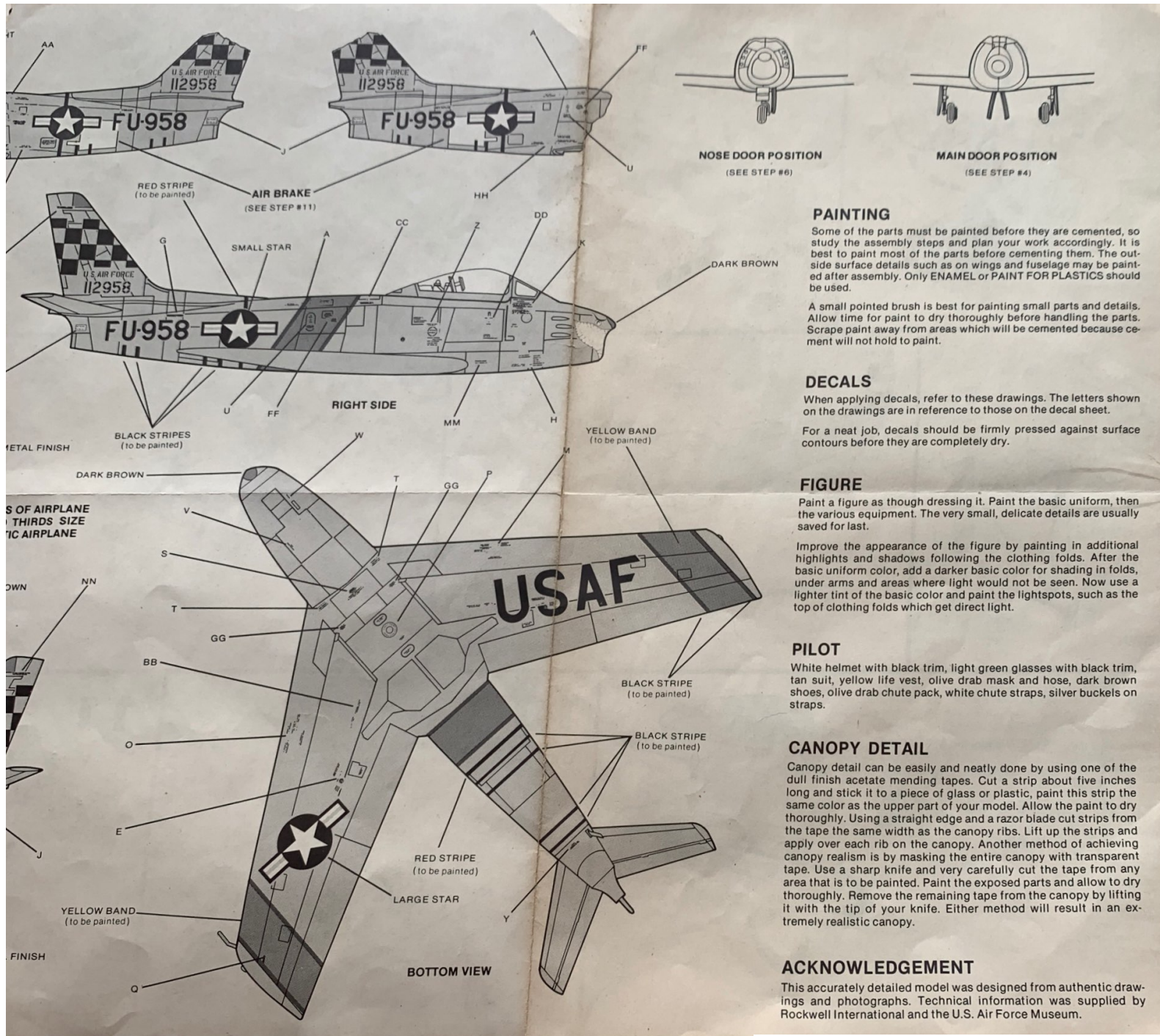

PAINTING

Some of the parts must be painted before they are cemented, so study the assembly steps and plan your work accordingly. It is best to paint most of the parts before cementing them. The outside surface details such as on wings and fuselage may be painted after assembly. Only ENAMEL or PAINT FOR PLASTICS should be used.

A small pointed brush is best for painting small parts and details. Allow time for paint to dry thoroughly before handling the parts. Scrape paint away from areas which will be cemented because cement will not hold to paint.

DECALS

When applying decals, refer to these drawings. The letters shown on the drawings are in reference to those on the decal sheet.

For a neat job, decals should be firmly pressed against surface contours before they are completely dry.

FIGURE

Paint a figure as though dressing it. Paint the basic uniform, then the various equipment. The very small, delicate details are usually saved for last.

Improve the appearance of the figure by painting in additional highlights and shadows following the clothing folds. After the basic uniform color, add a darker basic color for shading in folds, under arms and areas where light would not be seen. Now use a lighter tint of the basic color and paint the lightspots, such as the top of clothing folds which get direct light.

PILOT

White helmet with black trim, light green glasses with black trim, tan suit, yellow life vest, olive drab mask and hose, dark brown shoes, olive drab chute pack, white chute straps, silver buckles on straps.

CANOPY DETAIL

Canopy detail can be easily and neatly done by using one of the dull finish acetate mending tapes. Cut a strip about five inches long and stick it to a piece of glass or plastic, paint this strip the same color as the upper part of your model. Allow the paint to dry thoroughly. Using a straight edge and a razor blade cut strips from the tape the same width as the canopy ribs. Lift up the strips and apply over each rib on the canopy. Another method of achieving canopy realism is by masking the entire canopy with transparent tape. Use a sharp knife and very carefully cut the tape from any area that is to be painted. Paint the exposed parts and allow to dry thoroughly. Remove the remaining tape from the canopy by lifting it with the tip of your knife. Either method will result in an extremely realistic canopy.

ACKNOWLEDGEMENT

This accurately detailed model was designed from authentic drawings and photographs. Technical information was supplied by Rockwell International and the U.S. Air Force Museum.

PAINTING

Some of the parts must be painted before they are cemented, so study the assembly steps and plan your work accordingly. It is best to paint most of the parts before cementing them. The outside surface details such as on wings and fuselage may be painted after assembly. Only ENAMEL or PAINT FOR PLASTICS should be used.

A small pointed brush is best for painting small parts and details. Allow time for paint to dry thoroughly before handling the parts. Scrape paint away from areas which will be cemented because cement will not hold to paint.

DECALS

When applying decals, refer to these drawings. The letters shown on the drawings are in reference to those on the decal sheet.

For a neat job, decals should be firmly pressed against surface contours before they are completely dry.

FIGURE

Paint a figure as though dressing it. Paint the basic uniform, then the various equipment. The very small, delicate details are usually saved for last.

Improve the appearance of the figure by painting in additional highlights and shadows following the clothing folds. After the basic uniform color, add a darker basic color for shading in folds, under arms and areas where light would not be seen. Now use a lighter tint of the basic color and paint the lightspots, such as the top of clothing folds which get direct light.

PILOT

White helmet with black trim, light green glasses with black trim, tan suit, yellow life vest, olive drab mask and hose, dark brown shoes, olive drab chute pack, white chute straps, silver buckles on straps.

CANOPY DETAIL

Canopy detail can be easily and neatly done by using one of the dull finish acetate mending tapes. Cut a strip about five inches long and stick it to a piece of glass or plastic, paint this strip the same color as the upper part of your model. Allow the paint to dry thoroughly. Using a straight edge and a razor blade cut strips from the tape the same width as the canopy ribs. Lift up the strips and apply over each rib on the canopy. Another method of achieving canopy realism is by masking the entire canopy with transparent tape. Use a sharp knife and very carefully cut the tape from any area that is to be painted. Paint the exposed parts and allow to dry thoroughly. Remove the remaining tape from the canopy by lifting it with the tip of your knife. Either method will result in an extremely realistic canopy.

ACKNOWLEDGEMENT

This accurately detailed model was designed from authentic drawings and photographs. Technical information was supplied by Rockwell International and the U.S. Air Force Museum.