

SOVIET LIGHT BOMBER

Yakovlev Yak-6

Scale 1:72

Made in Russia

№7220

In 1941 it became clear that Red Army urgently need new light transport/ VIP aircraft to replace aged Polikarpov Po-2 and which couldn't meet VVS requirements any more.

Design work began in May 1942, the prototype made its maiden flight in August (record time!), and in November the first serial machine rolled out of production line and was service-named Yak-6.

Construction was extremely simple and reliable, and one ground crew could maintain two aircraft with no problem .

Airframe was made mainly of wood which allowed to build major components on a number of small furniture end woodworking factories to reduce damage of German bombing. The Yak-6 served as a light transport/ VIP, ground crew and spare parts carrier and light night bomber (Yak-6 NBB) trough in this version it proved to be ineffective and all built Yak-6 NBB-s were then used as a bombing pilots advanced trainers.

Ground attack version had 10 RS-82 rocket launchers and has been successfully used against German airfields.

Some serial machines had not retractable undercarriage and their wheel wells were covered with metal sheet. Total of 381 was built.

Crew:2 or 3.

Load:5 passengers or 500 Kg

Power plant: Two M-11F 140 h.p. five cylinder air cooled radials with wooden 2,2 m diametre propellers.

Dimensions:

Wing span, m: 14,0

Light, m:10,35

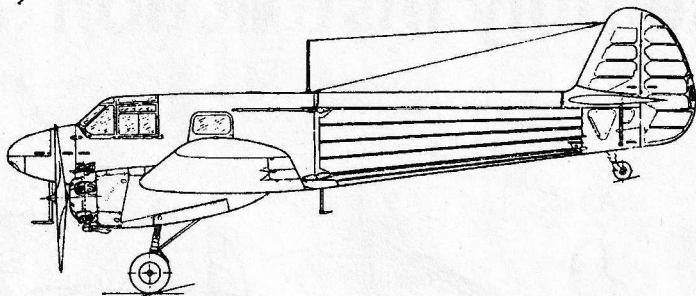

Assembly directions:

1. Use a sharp knife or a pair of scissors to remove parts from the sprue. For easy assembly each part is numbered. Paint small parts before removing from the sprue.
2. Care should be taken when using tools and modeling knives, as there can cause personal injury.
3. Plastic parts broken from sprues can have sharp, pointed or jagged edges. Remove these with a file or an emery board.
4. Keep out of the reach of children under 36 month old, as some parts are detachable. Children must not be allowed to suck any metal parts or wire included with this kit.
5. This document should be retained for reference at a later date, if the need arises, as it includes the «EEC» company name and address as a means of identification of importer and supplier.

Direction for applying the decals:

Cut each image out of the backing sheet: soak in water for about 1\2 minute; place the decal in exact position and remove the backing sheet.

Remove excess water with the cotton swab

MANUFACTURES :
ZVEZDA,
PROMYSHLENNAYA,
2- LOBNYA,
141730, RUSSIA

SELLER:
ITALERY SPA
VIA PRADAZZO,
6- CALDERARA
(BO), ITALY

Assembly instruction

2

1

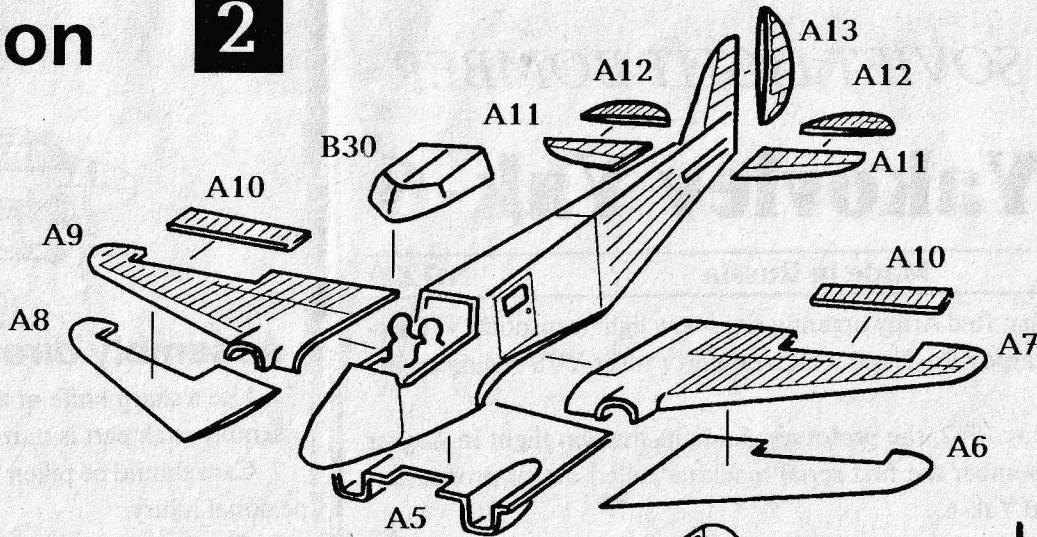
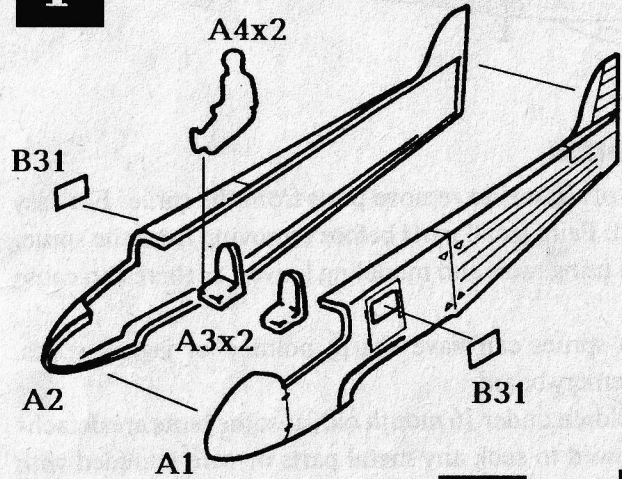

3

4

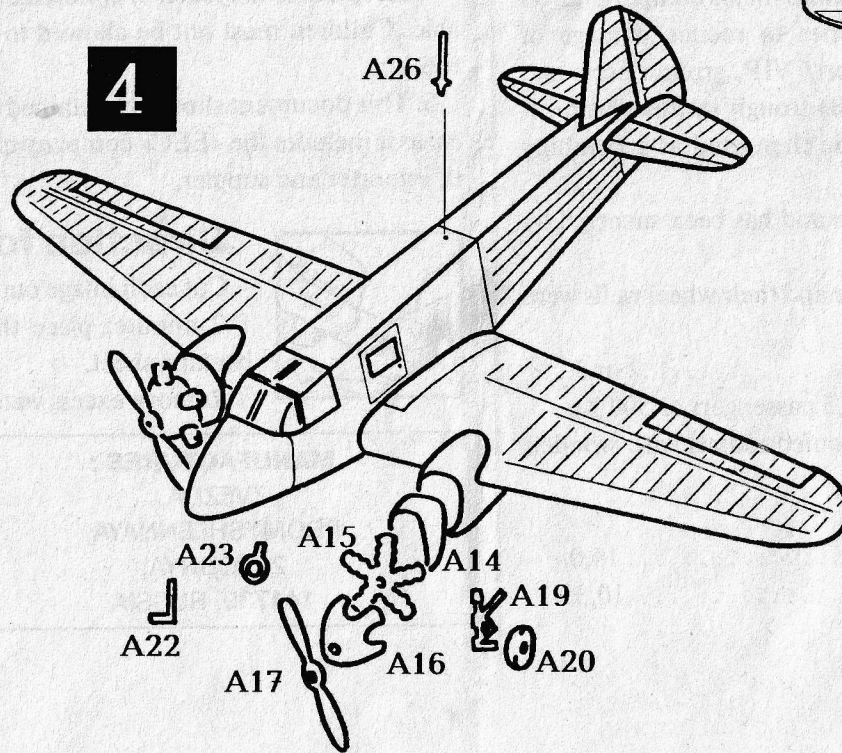
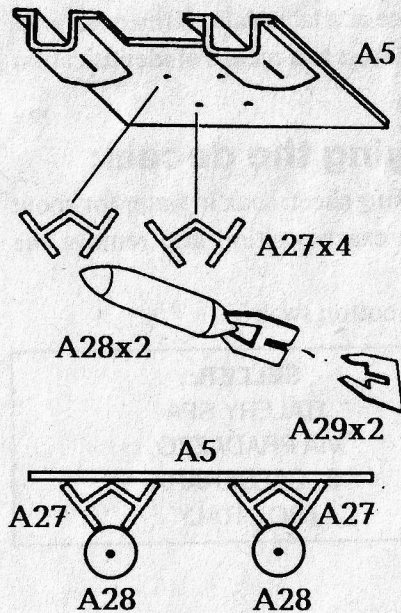

5

