

FROG

MOULDED IN
POLYSTYRENE

1/72nd SCALE MODEL
CONSTRUCTION KIT

MADE IN ENGLAND BY
INTERNATIONAL MODEL AIRCRAFT LTD

BLUE SERIES

CAT. No. 157P

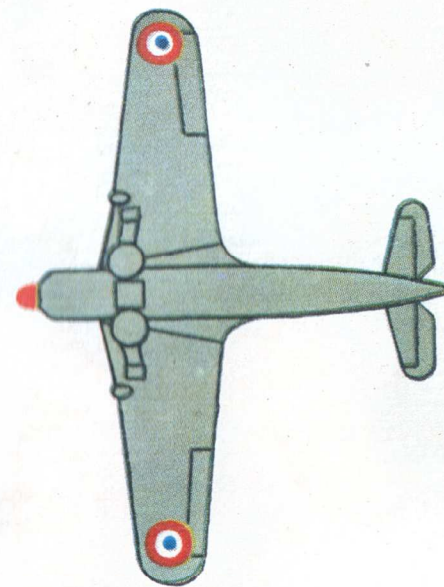
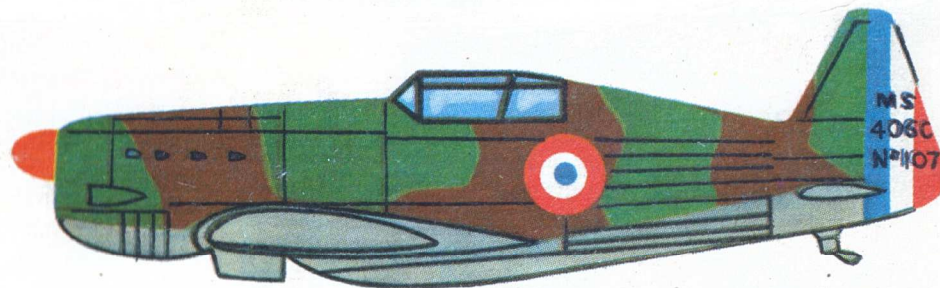

MORANE
SAULNIER 406C1
FIGHTER

At the outbreak of war in 1939 the Morane Saulnier was the principal French interceptor Fighter and although outclassed by the Messerschmitt BF109E, it was a brave Fighter and managed to claim 269 kills. Our Model—5 $\frac{1}{8}$ " Wing Span. Over 40 parts.

FROG

1/72 SCALE MODEL POLYSTYRENE KIT

THE S.N.C.A.O. MORANE SAULNIER 406C1

CAT. No. 157/P

It is recommended that the instructions and exploded view are studied and assembly practised before commencing.

Use Frog or Britfix Polystyrene cement and Frog or Humbrol paints.

It may be necessary in some cases to mix two or more colours to obtain shades required.

Paint all small parts before assembling.

Keep cement well away from face, eyes and clothing.

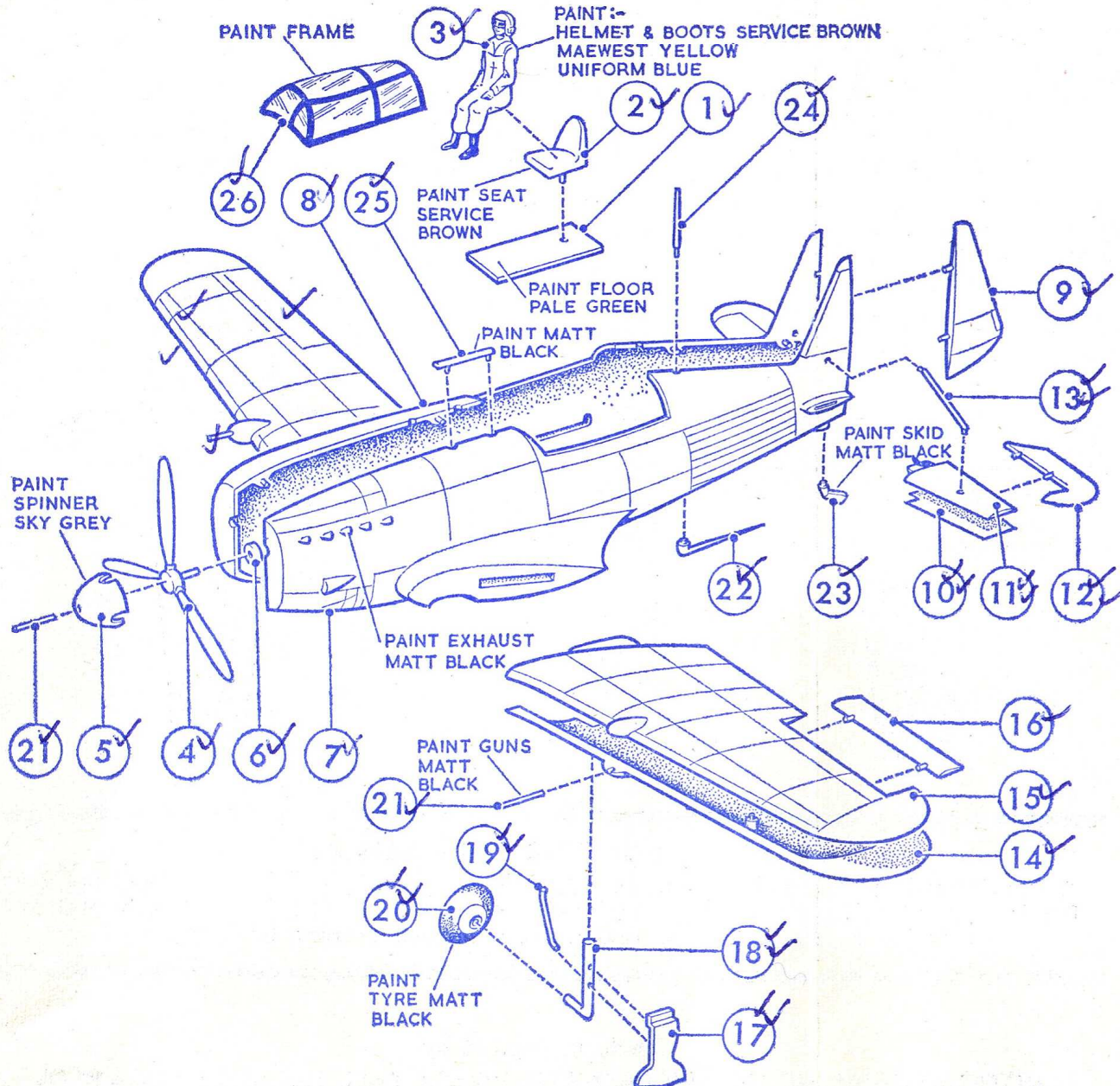

1. Cement and locate together Part Nos. 1 to 8, making sure that part No. 4 is able to rotate, allow to dry.

2. Cement and locate in position Part Nos. 9 to 13.

3. Cement and locate in position Part Nos. 14 to 16.

4. Cement and locate in position Part Nos. 17 to 19. Locate in position Part No. 20 and retain by spreading the ends of pins with a hot knife blade.

5. Cement and locate in position Part Nos. 21 to 26 in numerical order.

6. At this stage it is best to paint the model. See instructions for colours.

7. Apply transfers. First cut the sheet into 9 separate subjects, then dip each in water for about half a minute, slide off backing into position shown on illustration.

8. Cement together stand and locate arm of stand in slot on model.

HISTORY.

The forerunner of the Moraine Saulnier 406C1, was the M.S.405 which was first flown at Villaoullay on the 8th of August, 1935. To meet the requirements of the French Air Ministry Specification of 1934.

When the war began in 1939 the 406C1 was the French principal interceptor fighter, but with the German onslaught of 1940 it found itself outclassed by the Messerschmitt BF 109E, but even so the Armee de l'Air was able to claim 269 kills.

The Moraine Saulnier was also used by the Finnish, Polish and many other Air Forces.

DATA :

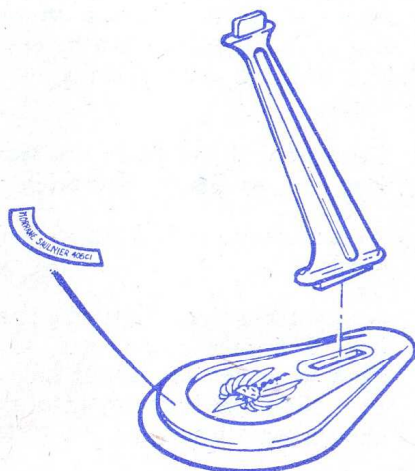

Span 34ft. 10ins.
Length 26ft. 11ins.
Power Plant — 860 h.p. Hispano-Suiza
12Y-31 twelve-cylinder liquid cooled
engine.

Max Speed ... 302 m.p.h.
Armament ... One 20 mm. Cannon.
Two 7.9 Chatellerault Machine Guns.

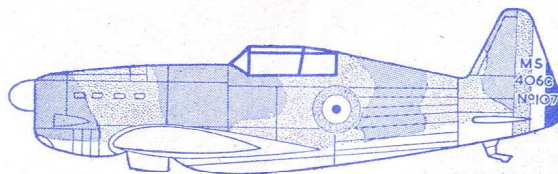

S.N.C.A.O. MORAINÉ SAULNIER 406C1



MATT CHESTNUT BROWN 
MATT OLIVE GREEN 
MATT SKY GREY 

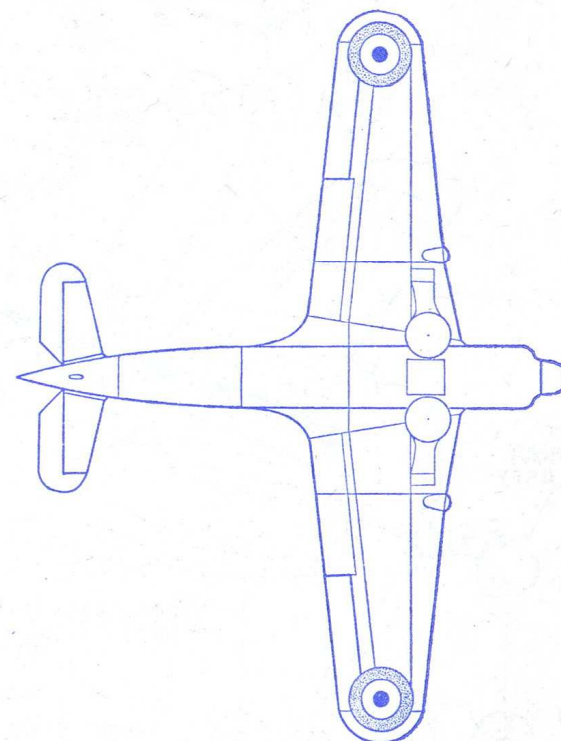
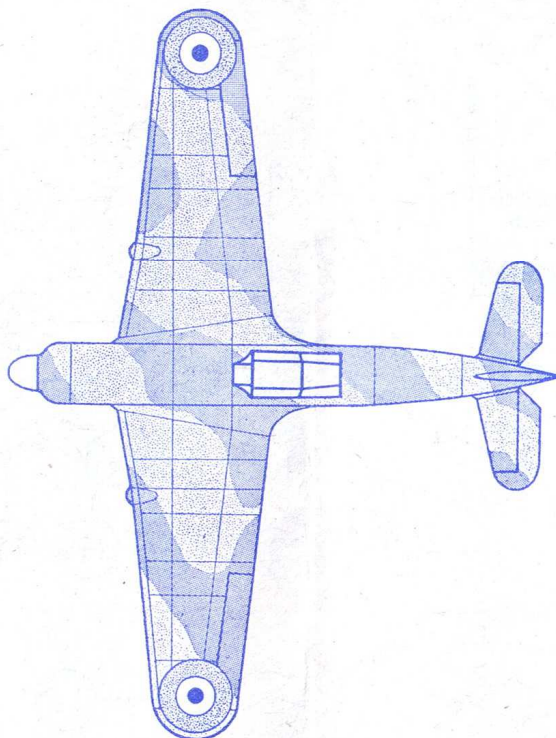

OTHER MODELS IN THIS RANGE :

Martin Marauder; Bristol Beaufort; Westland Wessex; Airspeed Oxford; G.A. Hotspur;
Percival Proctor; Hawker Sea Fury; Miles Master III; Dewoitine D.520C; Macchi M.C. 202
Folgore; Martin Baltimore; Fokker D21; Douglas Boston; Miles Magister.

Made in England by
INTERNATIONAL MODEL AIRCRAFT LTD., Morden Road, Merton, London, S.W.19.