



# Westland Lynx AH-7

**GB** Designed as a multi-purpose utility helicopter for both civil and military operators, the Westland Lynx has gone on to serve with countless navies across the World, as both a support and attack helicopter. The Lynx has also proved to be a massively capable attack and liaison machine over land as well as water. Entering service with the British Army in 1977, the Lynx has been continually upgraded from its earliest AH1 incarnation to become one of the British Army's most well-known and popular machines.

Its most numerous variant, as well as the most iconic, is the AH7. Originally equipped as an anti-tank, as well as utility helicopter, with an armament of TOW anti-tank missiles, the Lynx was then superseded in its anti-tank role by the more modern and capable Apache, but the Lynx continues to serve as a battlefield support machine and thanks to its armament of a single General Purpose Machine Gun (GPMG), it can still pack a punch.

**F** Conçu en tant qu'hélicoptère utilitaire polyvalent pour les opérateurs civils et militaires, le Westland Lynx a été adopté par d'innombrables armées de mer partout dans le monde comme appareil d'appui et d'attaque. Le Lynx s'est avéré également être un hélicoptère d'attaque et de liaison très performant tant sur terre que sur mer. Entré en service au sein de l'armée de terre britannique en 1977, le Lynx s'est amélioré progressivement à partir de sa première version AH1 pour devenir l'un des appareils les plus connus et les plus populaires de l'armée britannique.

Variante la plus nombreuse ainsi que la plus célèbre, le AH7 était équipé au départ comme hélicoptère utilitaire ainsi que de frappe anti-char, étant armé de missiles TOW. Le Lynx a été ensuite remplacé pour le rôle anti-char par l'Apache plus avancé et plus performant mais continue en tant qu'appareil d'appui sur le champ de bataille. Grâce à son armement d'une seule mitrailleuse d'usage général, il est toujours capable de donner un coup dévastateur.

**D** Als Universalhubschrauber zur zivilen und militärischen Nutzung konzipiert, wird der Westland Lynx seit seiner Einführung von zahlreichen Seestreitkräften auf der ganzen Welt sowohl in Unterstützungsfunktionen als auch als Angriffshelikopter eingesetzt. Der Lynx hat sich dabei als äußerst leistungsstarke Angriffs- und Verbindungsmaschine über Land wie auch Wasser bewährt. Von der British Army 1977 in den Dienst genommen, wurde der Lynx von seiner Ausgangsversion AH1 an kontinuierlich verbessert und wurde schließlich eine der bekanntesten und am weitesten verbreiteten Maschinen der Army.

Als zahlenmäßig größte Variante hat der AH7 praktisch einen Kultstatus erreicht. Ursprünglich zur Bekämpfung von Panzern mit TOW Panzerabwehr-Raketen bestückt wie auch für den Mehrzweckinsatz ausgerüstet, wurde der Lynx schließlich in seiner Rolle für die Bekämpfung von Panzern durch den moderneren und leistungsfähigeren Apache ersetzt. Der Lynx verrichtet jedoch weiterhin seinen Dienst in der Rückendeckung bei Schlachtfeldsätzen, wobei er durch seine Ausstattung mit einem Allzweck-MG (General Purpose Machine Gun - GPMG)

**E** Diseñado como helicóptero de utilidad multiuso tanto para operadores civiles como militares, el Westland Lynx ha servido en numerosas armadas del mundo, tanto como helicóptero de apoyo como de ataque. El Lynx ha demostrado también ser una máquina masivamente capaz de ataque y coordinación tanto en tierra como en agua. El Lynx que entró en servicio con la Armada Británica en 1977, ha sido continuamente mejorado desde su primera encarnación AH1 para convertirse en la máquina más popular y conocida de la Armada Británica.

Su variante más numerosa, además de la más icónica, es la AH7. Equipado originalmente como antitanque, además de como helicóptero utilitario, con armamento de misiles antitanque TOW, el Lynx fue reemplazado en su papel antitanque por el más moderno y capaz Apache, pero el Lynx continúa sirviendo como máquina de apoyo de batalla y gracias a su armamento de ametralladora de uso general (GPMG), todavía puede pegar fuerte.

Después de haber estado en servicio en ambas Guerras del Golfo, además de

**S** Westland Lynx, en multirollhelikopter som är avsedd för både civila och militära uppdrag, har tagits i tjänst av flera flottstyrkor världen över både som support- och attackhelikopter. Lynx har även visat sig vara en mycket kapabel attack- och samordningsmaskin över både land och vatten. Lynx inledde sin tjänstgöring i den brittiska armén 1977 och har därefter kontinuerligt uppraderats från sin ursprungliga AH1-version till en av den brittiska arméns mest välkända och populära maskiner.

Den mest förekommande och ikoniska variant är AH7. Lynx, som ursprungligen utrustades som pansarvärns- och universalhelikopter (beväpnad med TOW-pansarvärnsrobotar), uppraderades så småningom till en mer modern och kapabel Apache-helikopter, men fortsätter ändå att tjänstgöra som supporthelikopter på slagfältet, och dess beväpning i form av en enda General Purpose Machine Gun (GPMG),

Seeing service in both Gulf Wars, as well as operations in the Balkans and Kosovo, the Lynx has proven itself to be an excellent weapon and with its speed and manoeuvrability having no equals, it is one of very few helicopters able to be looped, something it performs dramatically at air shows.

As well as being operated by the Army, the AH7 Lynx has seen service with the Fleet Air Arm, with machines on loan from the Army, as part of the Joint Helicopter Force in Afghanistan. Today, the AH7 is due to be replaced by the more capable AH9 in many frontline roles, but it will continue to be used by the Army, as well as the Marines and Navy for many years to come, due to its excellent characteristics.

Speed: 201mph; Length: 15.2m; Rotor diameter: 12.8m.

Armament: 1 x 7.62mm GPMG + Tow Missiles.

Opérationnel pendant les deux guerres du Golfe ainsi que lors des opérations aux Balkans et en Kosovo, le Lynx s'est révélé être une excellente arme dotée d'une vitesse et manoeuvrabilité sans pareil. C'est l'un des très rares hélicoptères capables de faire un looping, acrobatie exécutée de façon spectaculaire aux salons de l'aéronautique.

En plus d'être opéré par l'armée, le Lynx AH7 s'est engagé au sein de l'Aéronavale : plusieurs appareils de l'armée ont été empruntés pour participer à la force commune d'hélicoptères en Afghanistan. Aujourd'hui, le AH7 est prévu d'être remplacé par le AH9 plus performant dans de nombreux rôles de première ligne mais son utilisation par l'armée, par l'infanterie de marine et par la Royal Navy continuera pendant des années grâce à ses caractéristiques excellentes.

Vitesse : 320 km/h ; Longueur : 15,2 m ; Diamètre du rotor : 12,8 m .

Armement : une mitrailleuse d'usage général de 7,62 mm + missiles TOW.

weiterhin seine Schlagkraft unter Beweis stellen kann.

In beiden Golfkriegen wie auch bei Operationen im Balkan und in Kosovo eingesetzt, hat sich der Lynx als hervorragende Waffe bewährt. Mit seiner sonst unerreichten Geschwindigkeit und Wendigkeit gehört er zu den wenigen Hubschraubern, die auch zu Loopings tauglich sind – einer Fähigkeit, die immer wieder bei Flugschauen deren Besucher begeistert.

Abgesehen von seiner Verwendung bei der British Army wird der AH7 Lynx auch vom Fleet Air Arm mit von der Army geliehenen Maschinen als Teil der Joint Helicopter Force in Afghanistan eingesetzt. Heute ist zwar vorgesehen, dass der AH7 für den Frontliniendienst durch den leistungsstärkeren AH9 ersetzt wird, doch soll er aufgrund seiner hervorragenden Eigenschaften weiterhin bei der Army wie auch den Marines und der Navy noch viele Jahre lang seinen bewährten Dienst verrichten.

Geschwindigkeit: 320 km/h; Länge: 15,2 m; Rotordurchmesser: 12,8 m. Bewaffnung: ein 7,62 mm GPMG und TOW Raketen.

participar en operaciones en los países balcánicos y en Kosovo, el Lynx ha demostrado ser un arma excelente y con su velocidad y facilidad de manejo sin igual, es uno de los pocos helicópteros capaces de rizar el rizo, algo que realiza de forma dramática en demostraciones de acrobacia aérea.

Además de haber sido operado por la armada, el AH7 Lynx ha estado en servicio con la Fuerza Aérea Naval, con máquinas prestadas por la armada, como parte de la Fuerza de Helicópteros Unidos en Afganistán. Hoy en día, el AH7 está a punto de ser reemplazado por el más capaz AH9 en muchos papeles de primera línea, pero continuará siendo utilizado por la armada, además de por la Infantería de Marina y la Marina de Guerra durante muchos años, debido a sus excelentes características.

Velocidad: 320km/h; Longitud: 15,2m; diámetro del rotor: 12,8m.

Armamento: 1 x ametralladora de uso general de 7,62mm (GPMG) + Misiles TOW.

kan fortfarande orsaka stor skada.

Lynx, som användes i båda gulfkrigen, Balkan och Kosovo, har visat sig vara ett utmärkt vapen som inte har några motsvarigheter vad gäller hastighet och manövrerbarhet. Den är en av mycket få helikoptrar som kan göra en looping, något som uppskattas mycket under flyguppvisningar.

AH7 Lynx används inte bara av armén, Den har även lånats ut till flottans flygavdelning som en del av "Joint Helicopter Force" i Afghanistan. AH7 kommer inom kort att ersättas av den på fronten mer kapabla AH9, men dess utmärkta egenskaper kommer ändå att nyttjas av armén i flera år framöver.

Hastighet: 320 km/h; Längd: 15,2 m; Rotordiameter: 12,8 m.

Beväpning: 1 st. 7,62 mm GPMG + TOW-robot.

**PLEASE NOTE :** Some parts in the kit may not be required to build the model.



1  
A  
B  
C

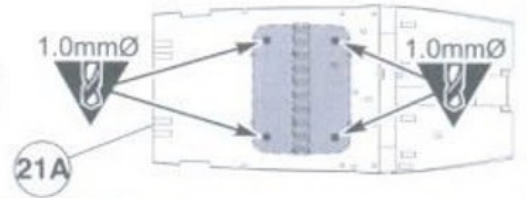
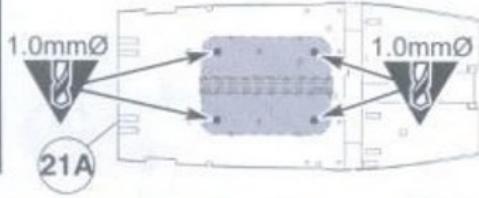

A

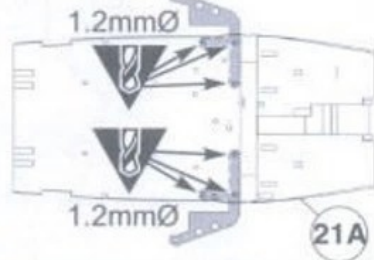

3a

BC



3b

A

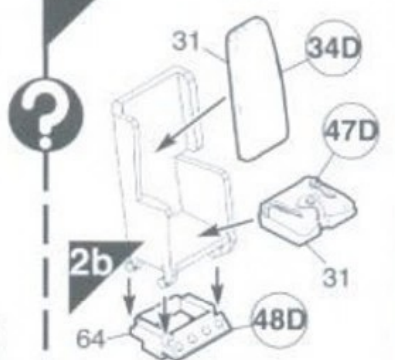

2a BC

2b A

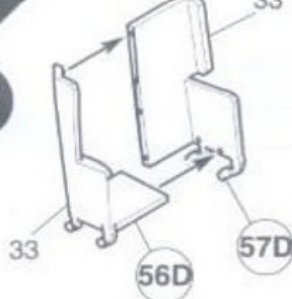

5a

4a BC



5b

A



4a BC

4b A

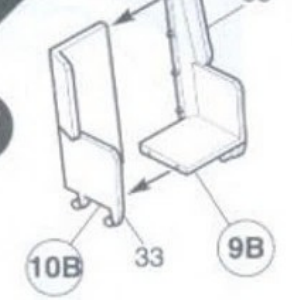

6

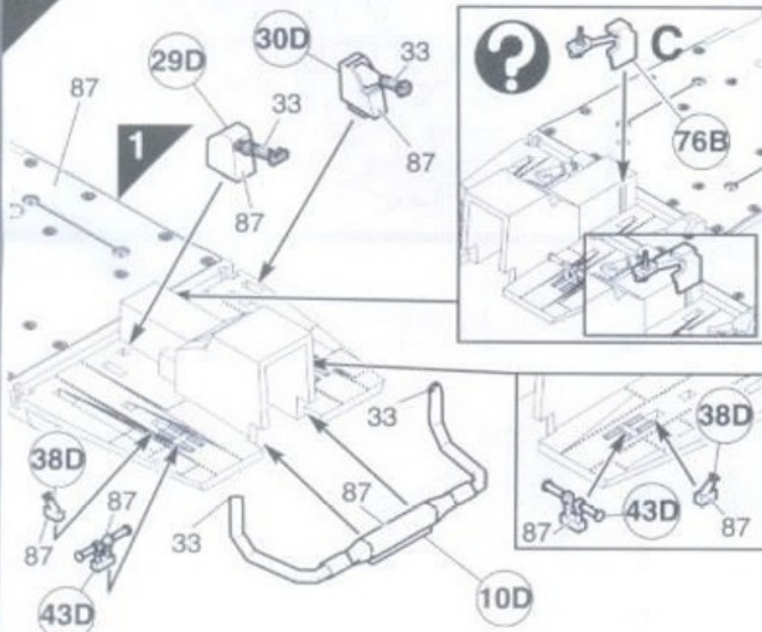

7

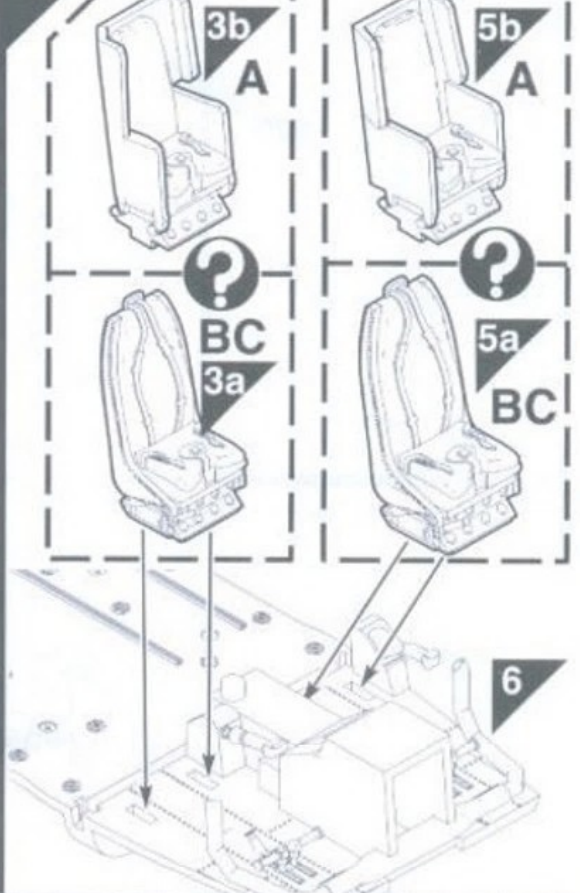



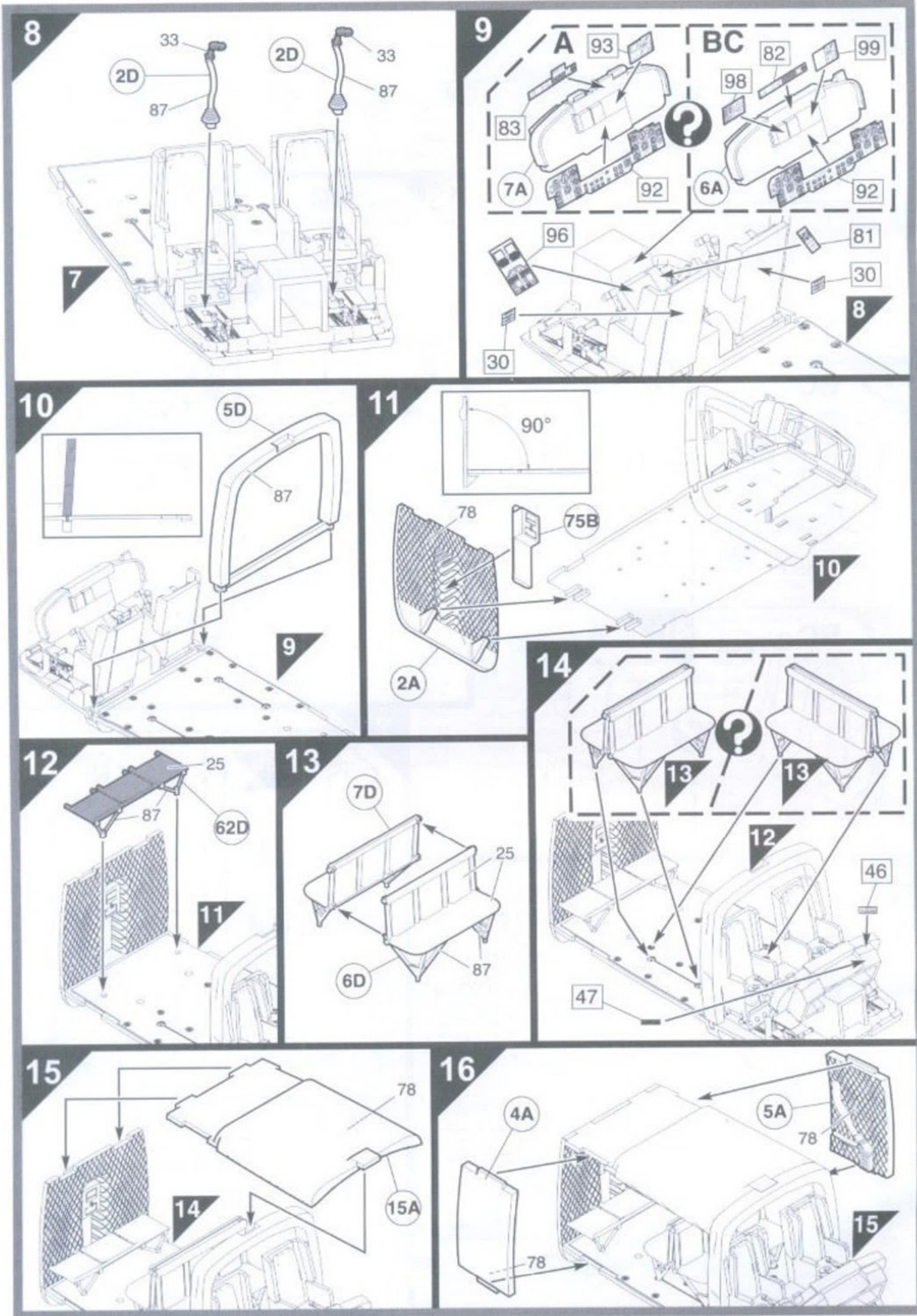



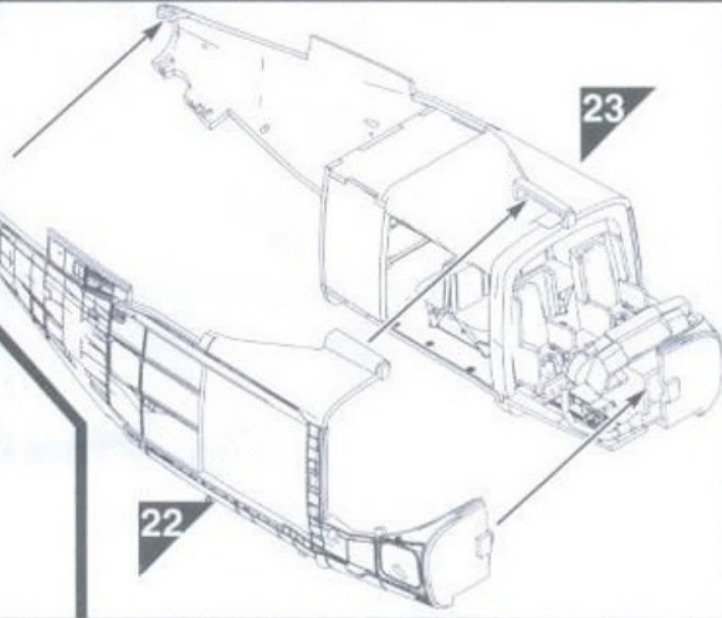
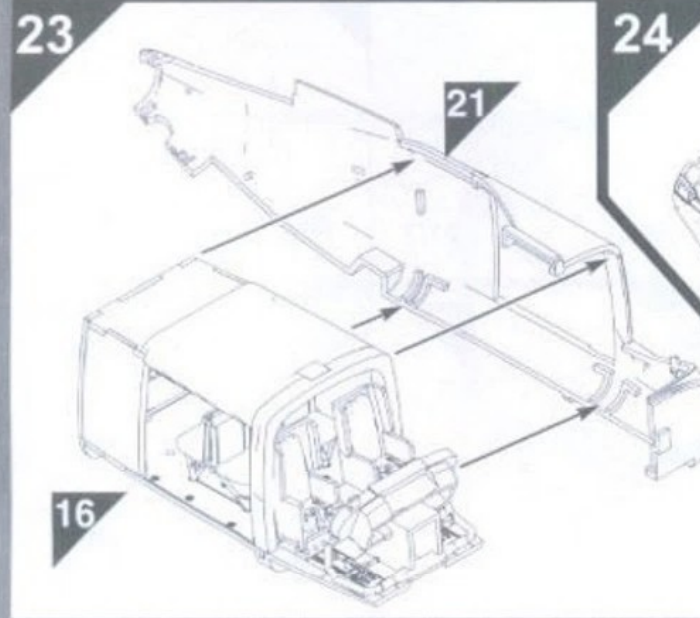
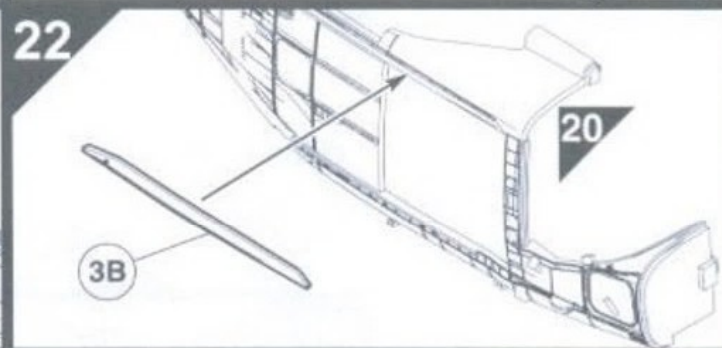
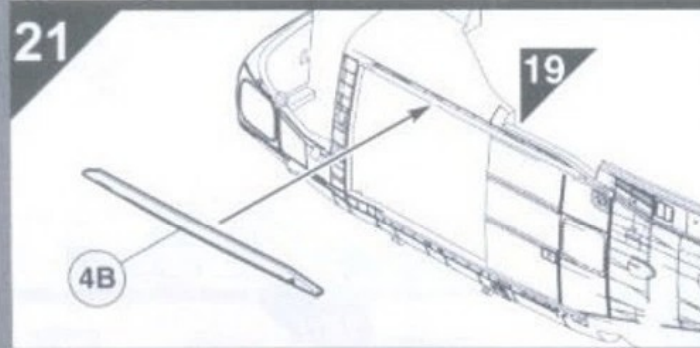
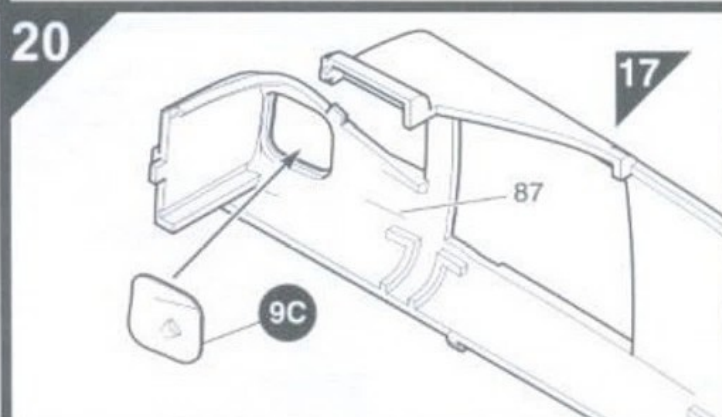
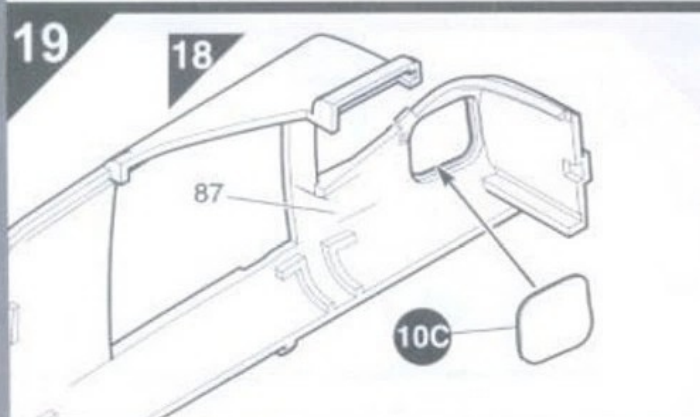
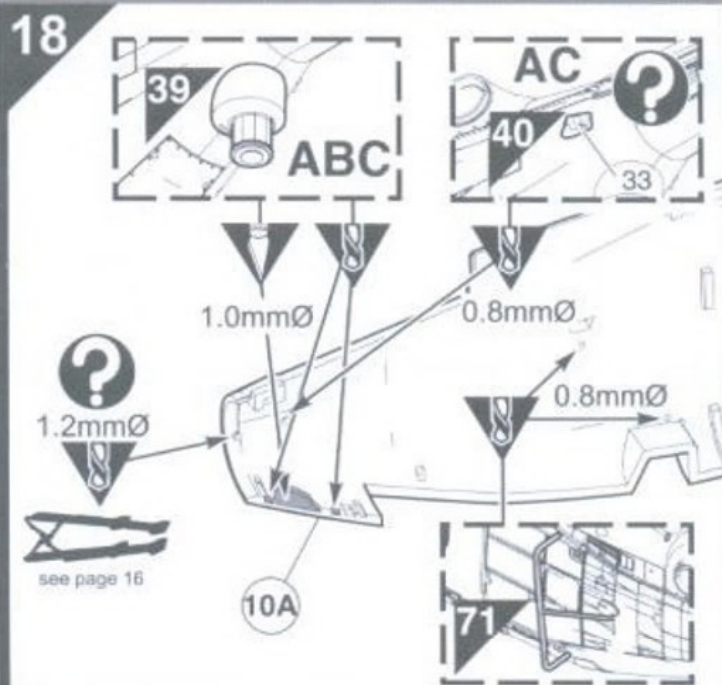
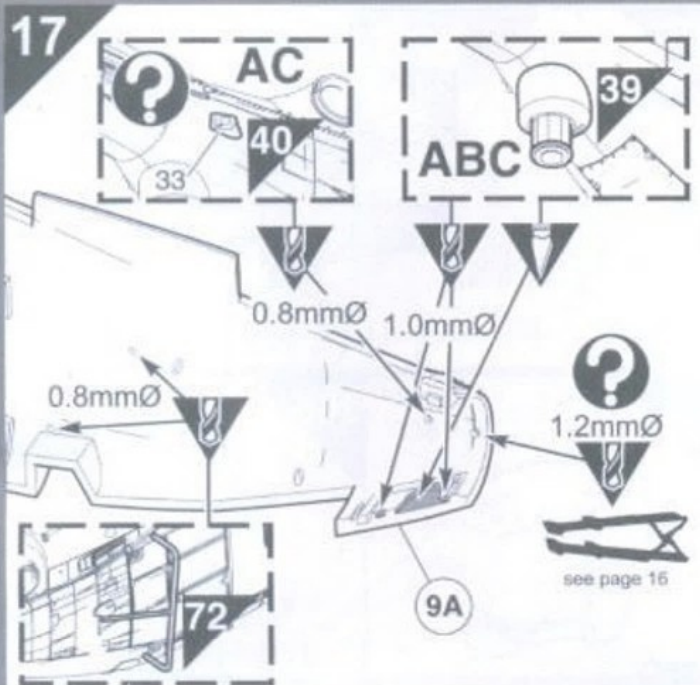



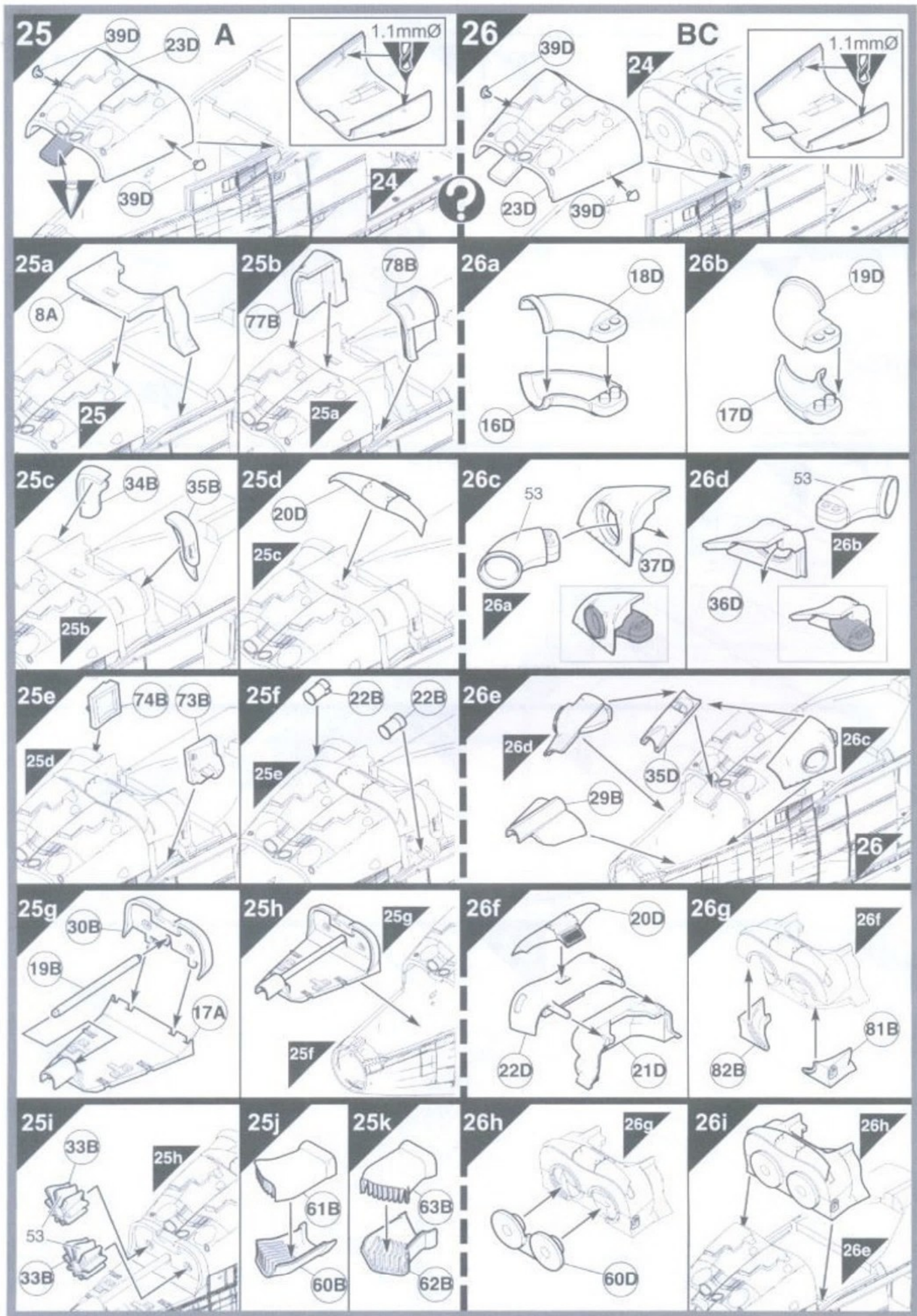



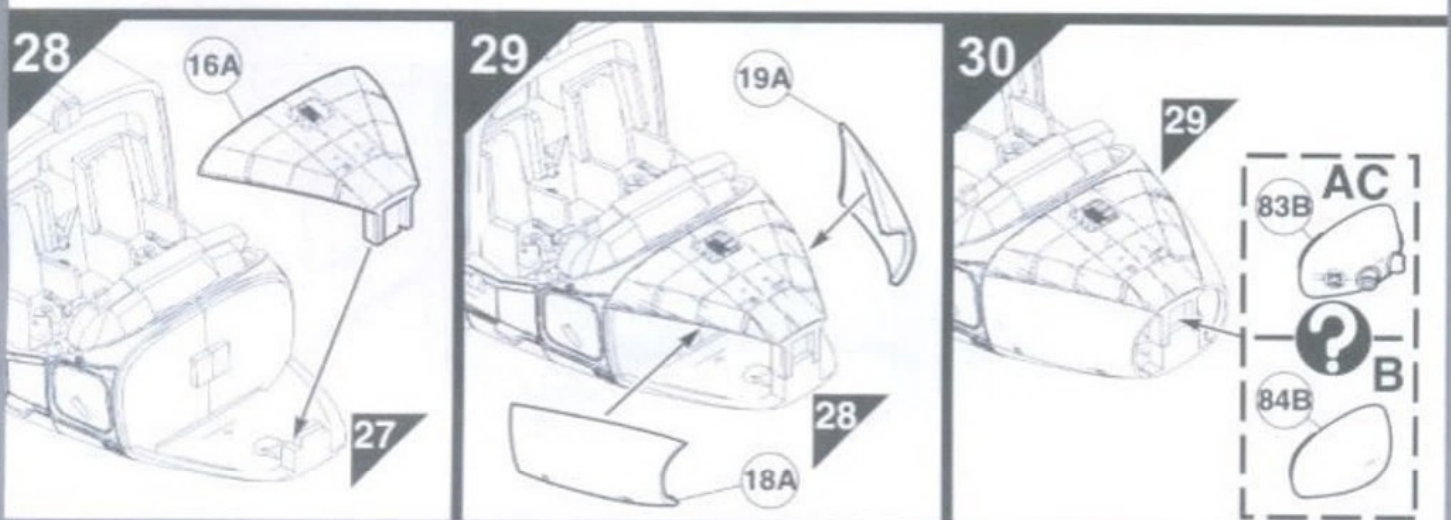
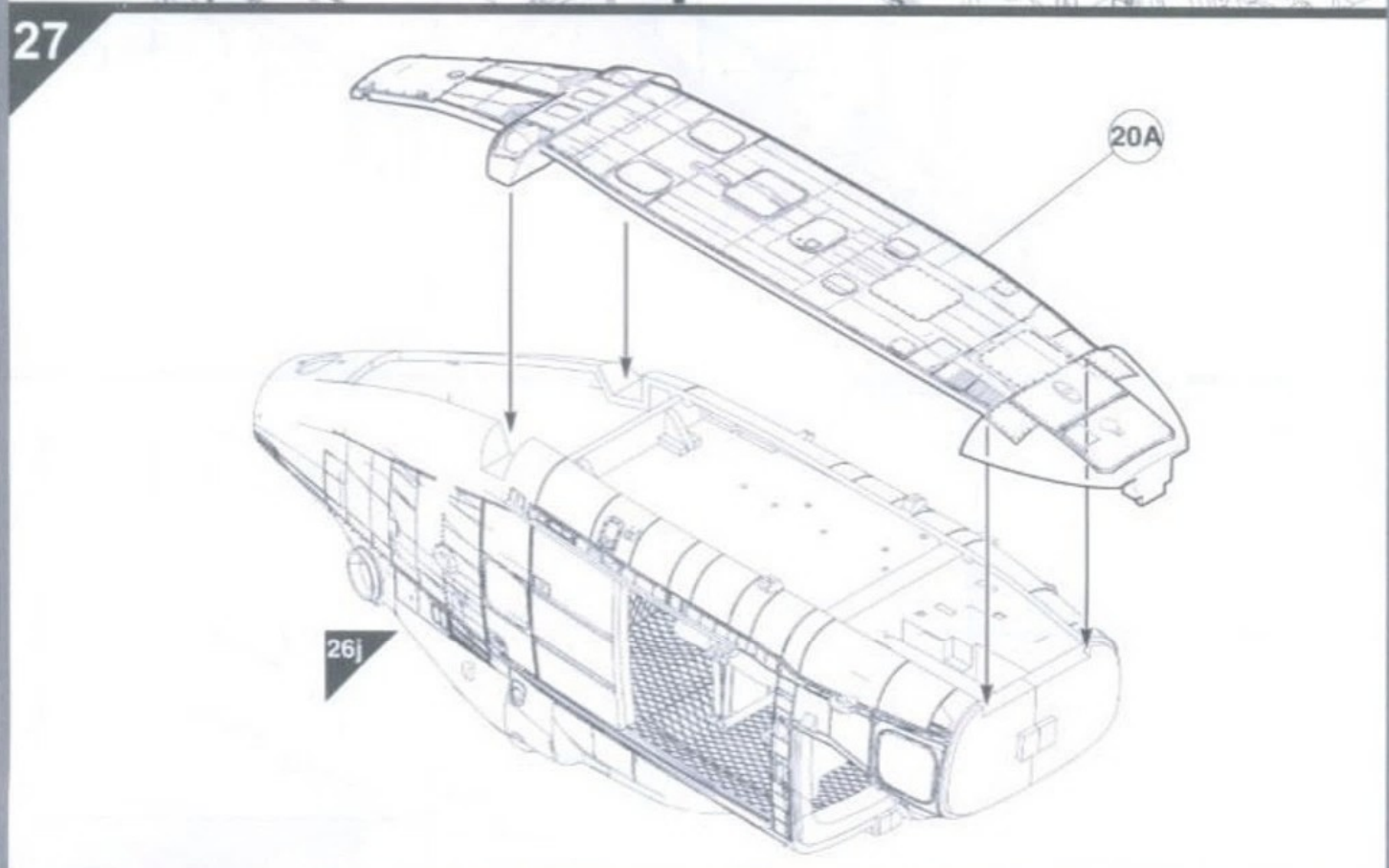
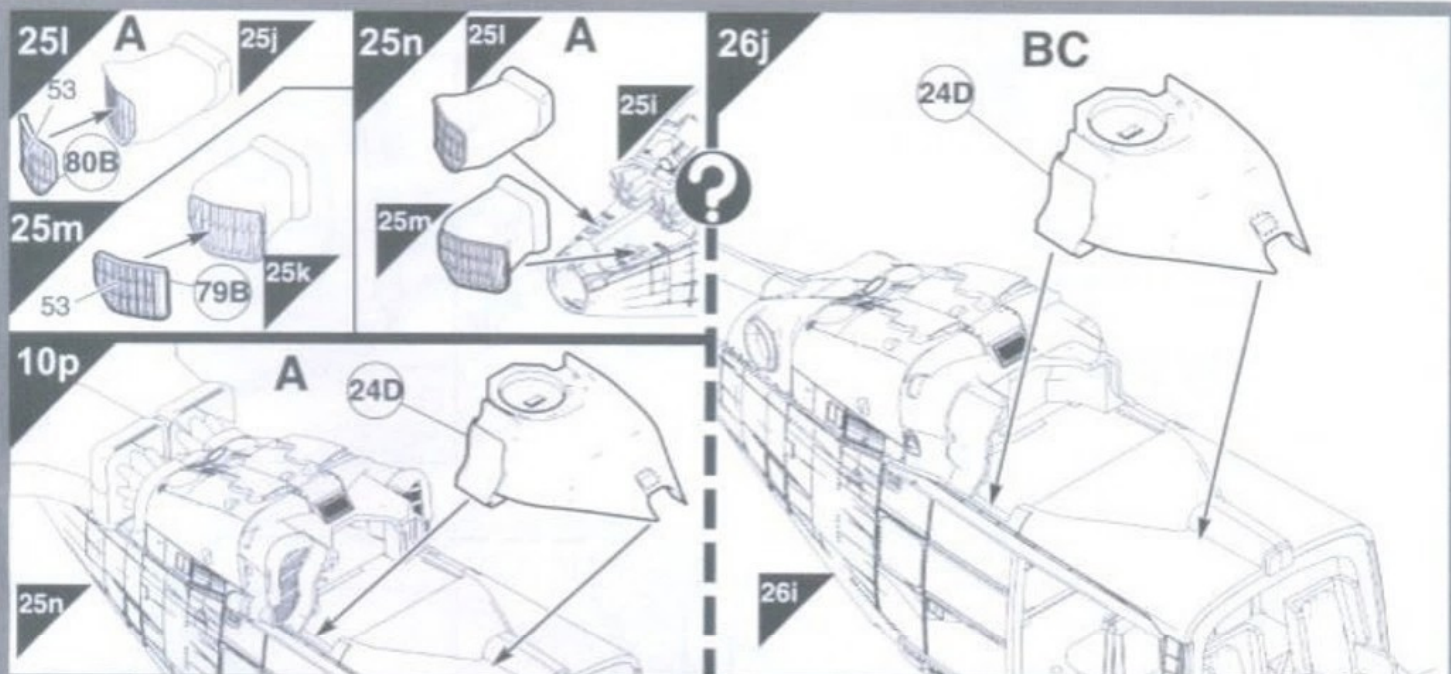



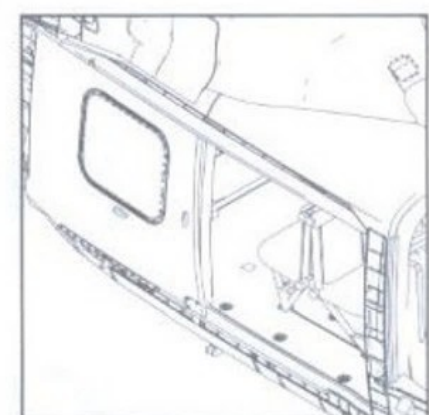
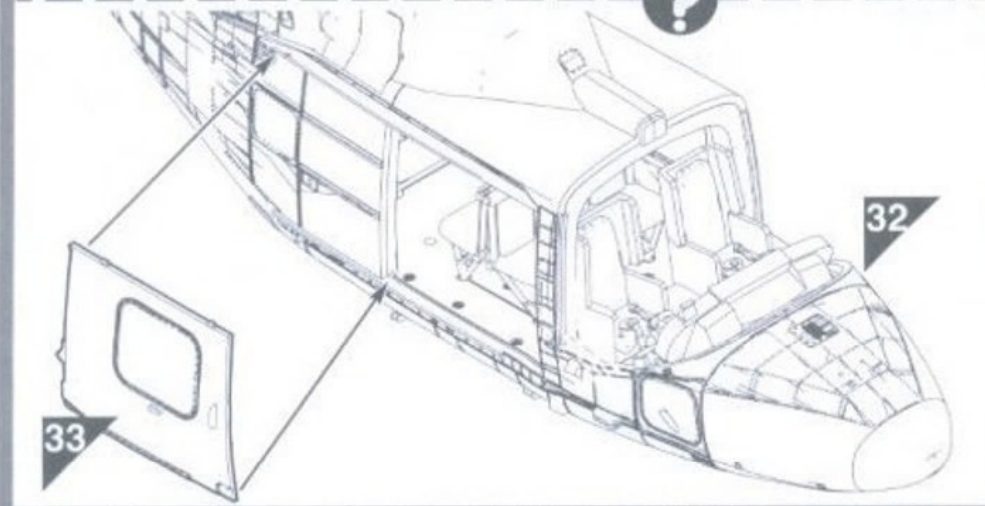
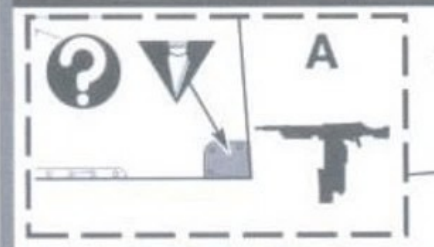
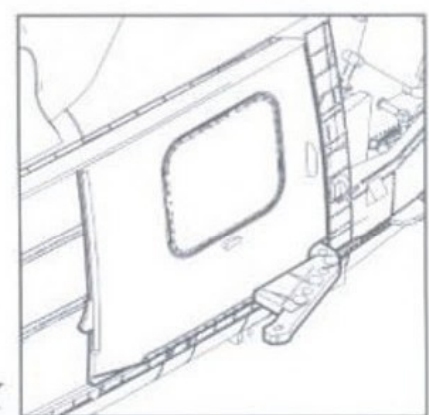
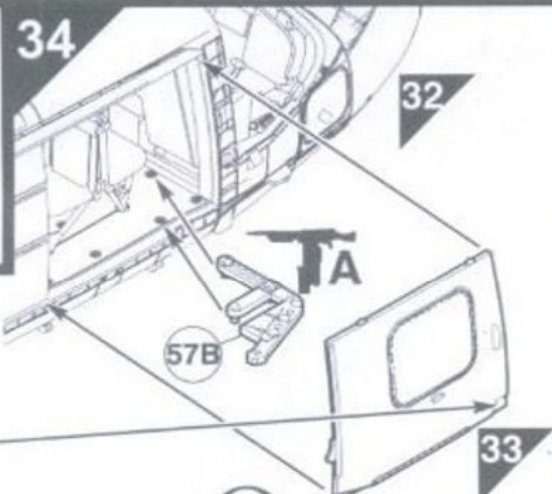
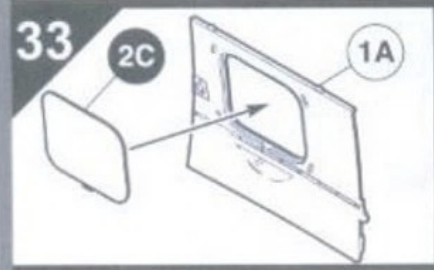
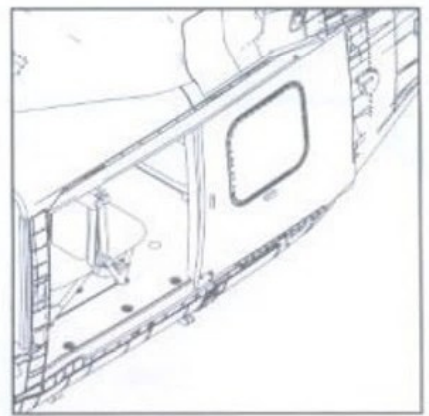
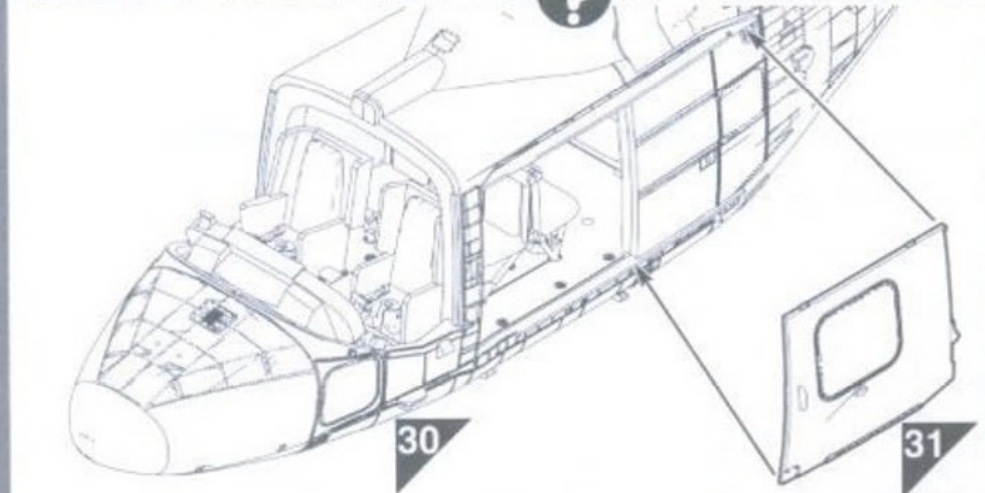
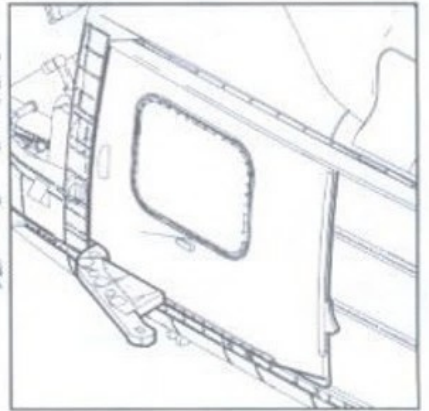
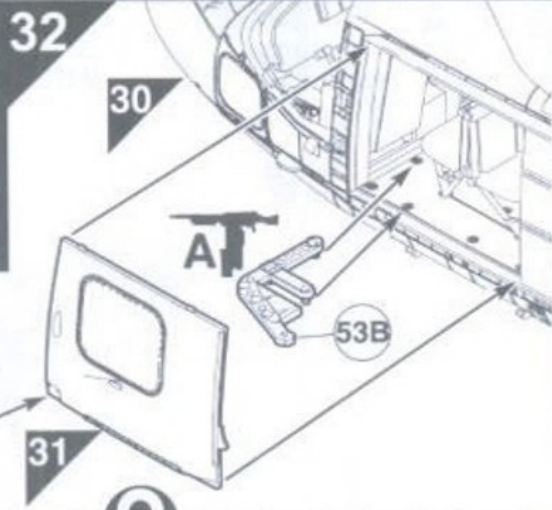
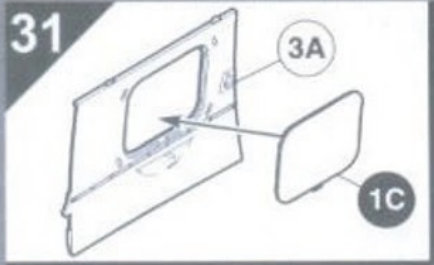



35

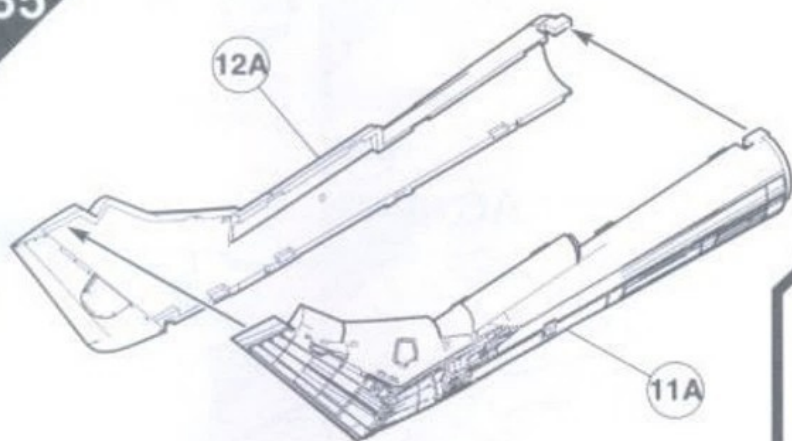

36

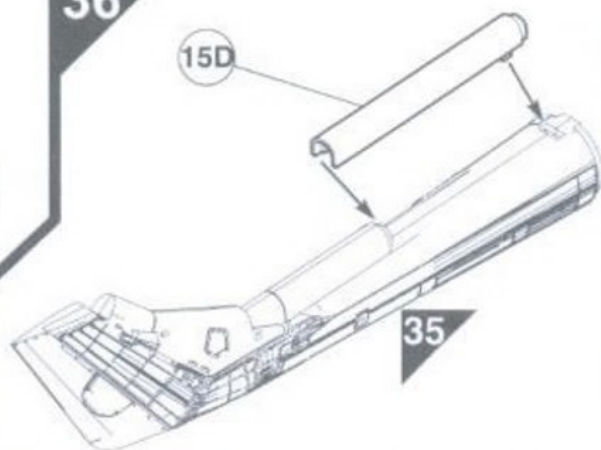

37

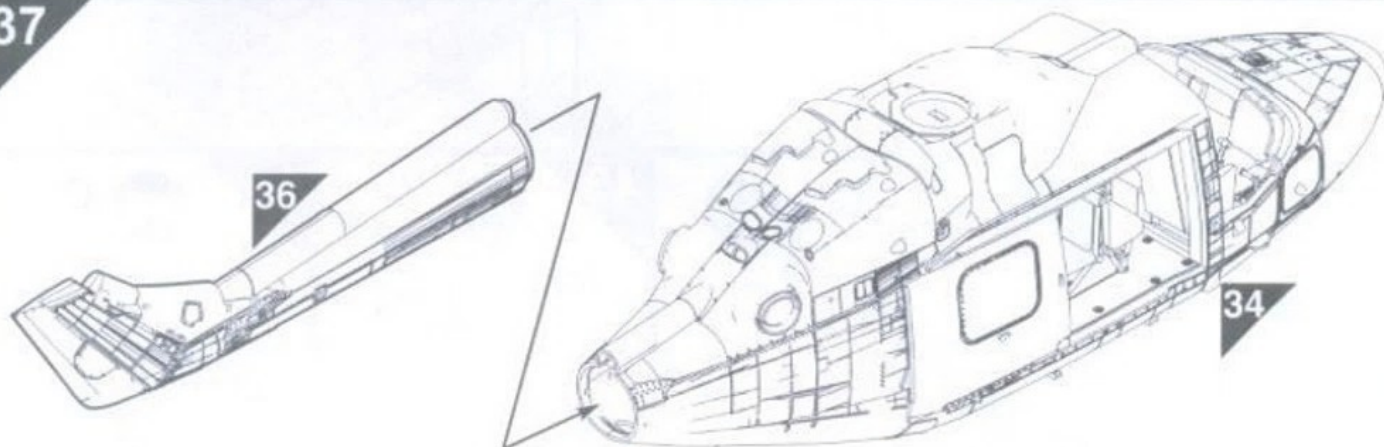

38a

AC

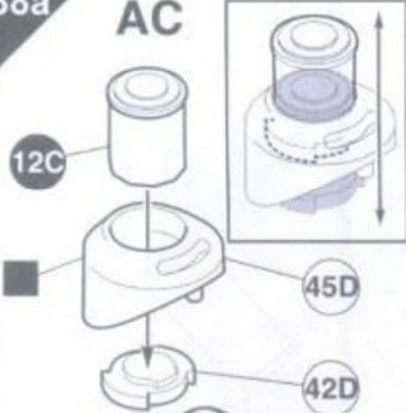

39

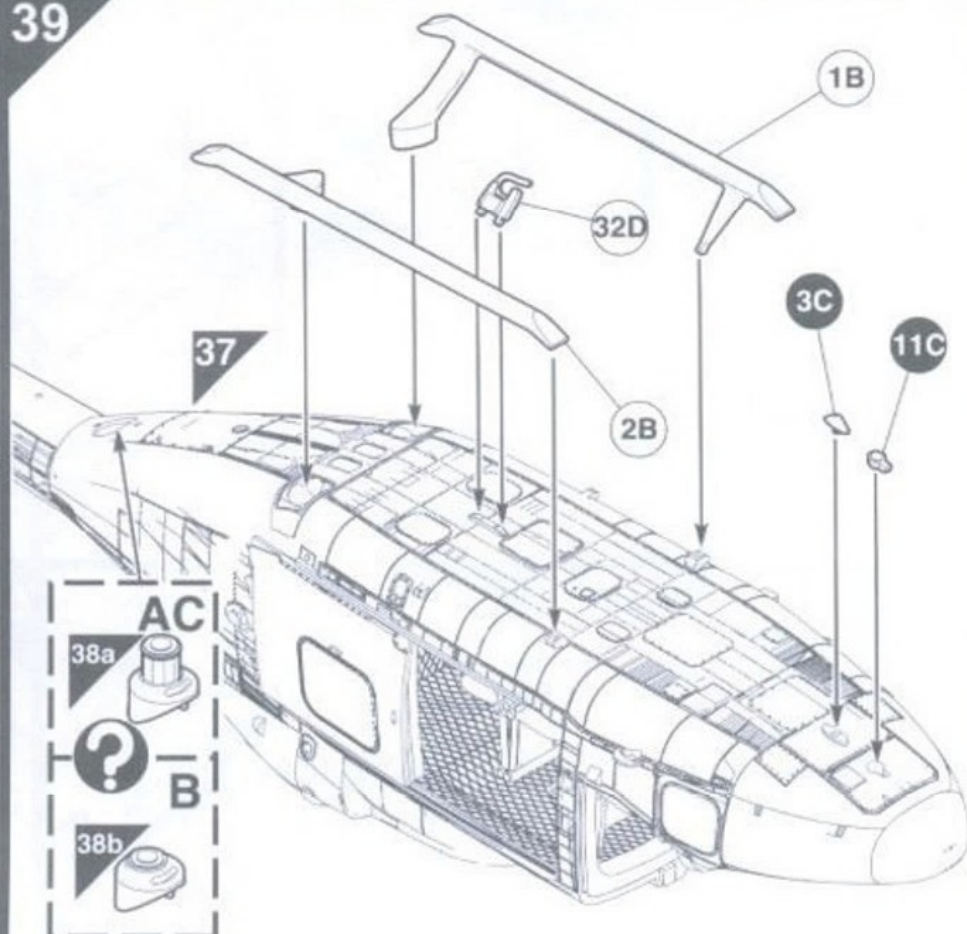

38b

B

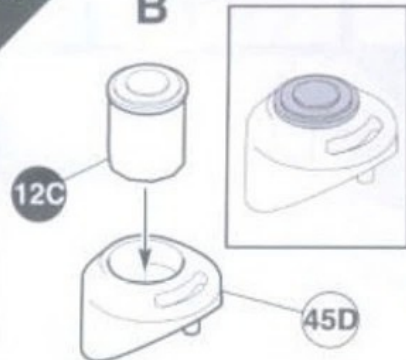



40

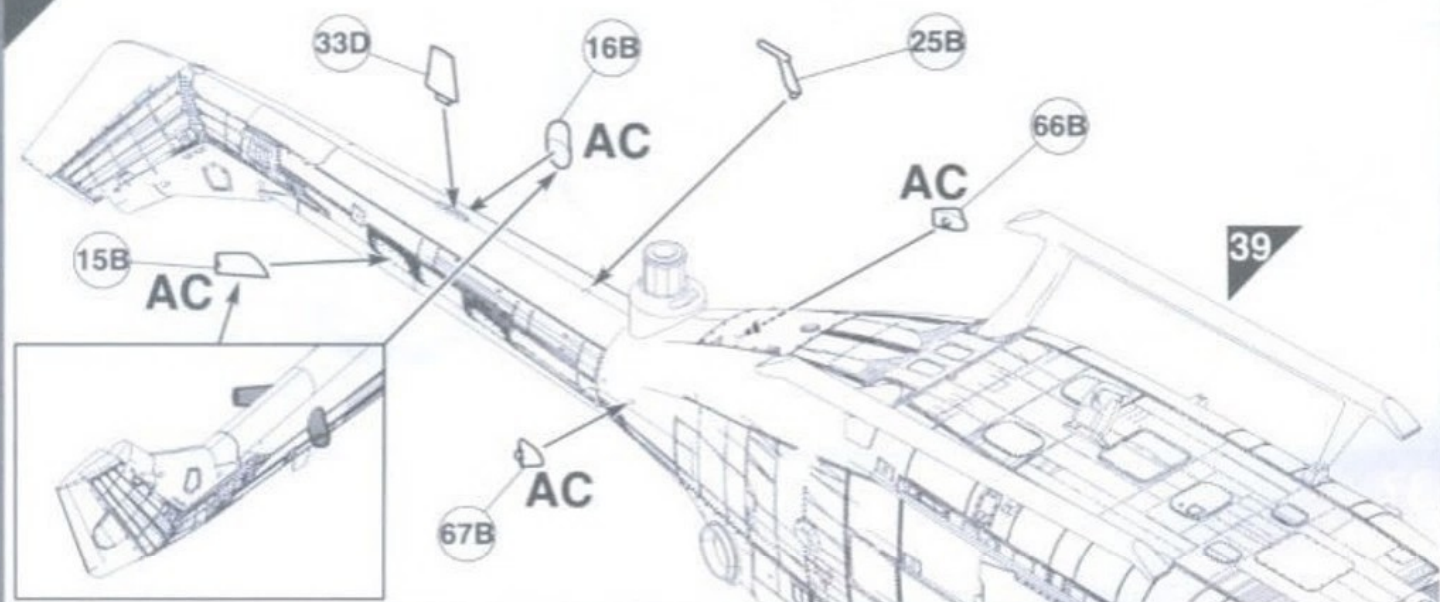

41

C x4

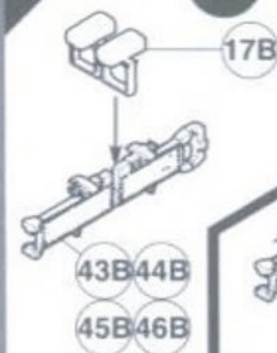

42

C x4

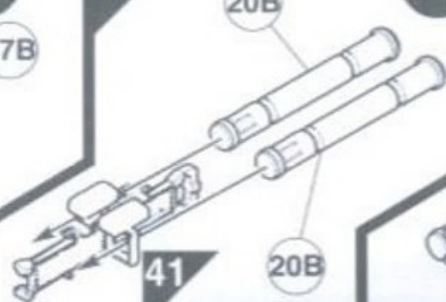

43

x4 C

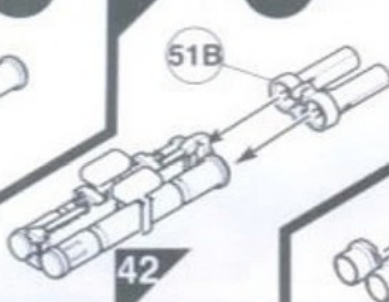

44

x4 C

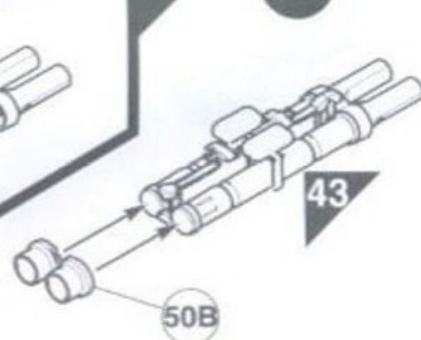

45

x2 C

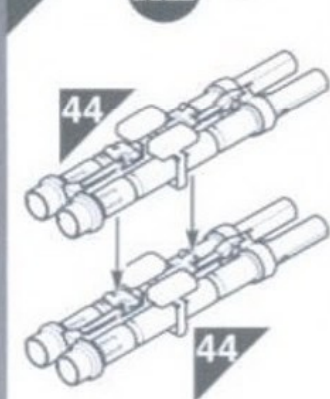

46

C

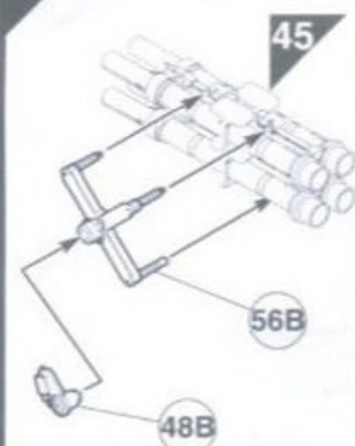

47

C

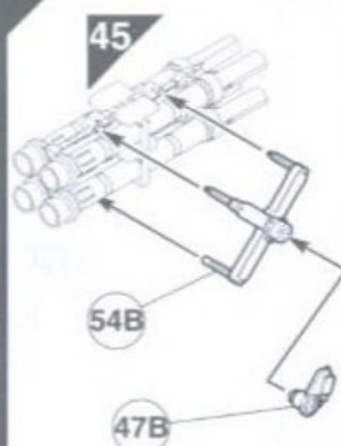

48

C

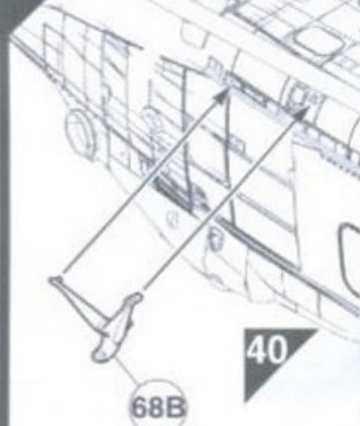

49

C

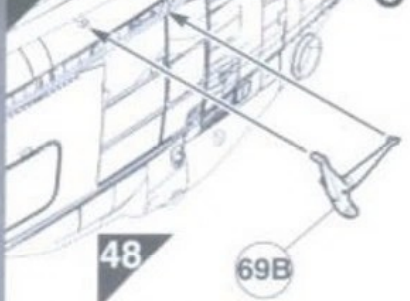

50

C



51

C

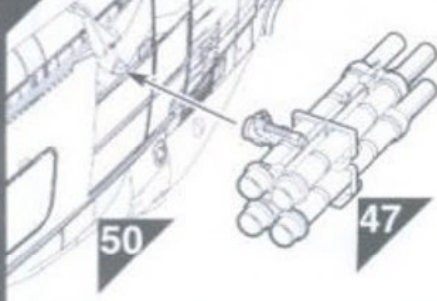



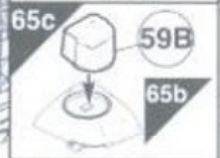
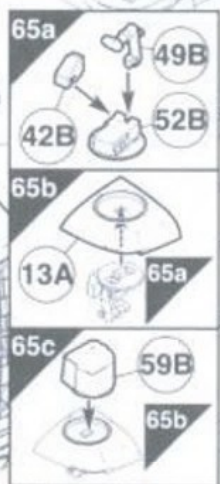
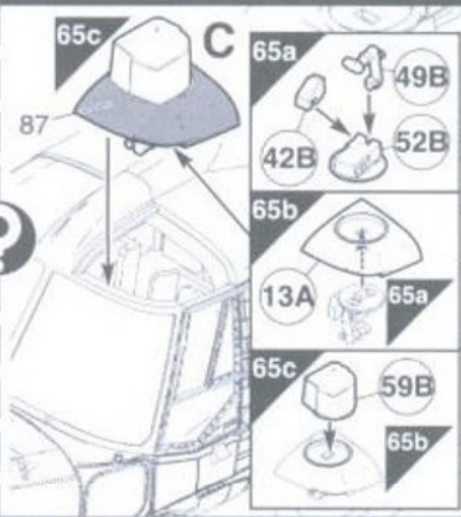
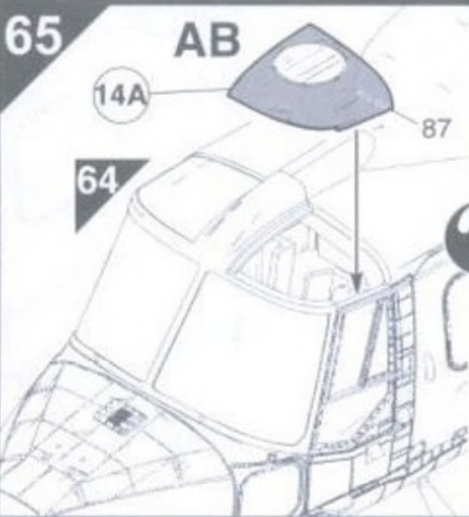
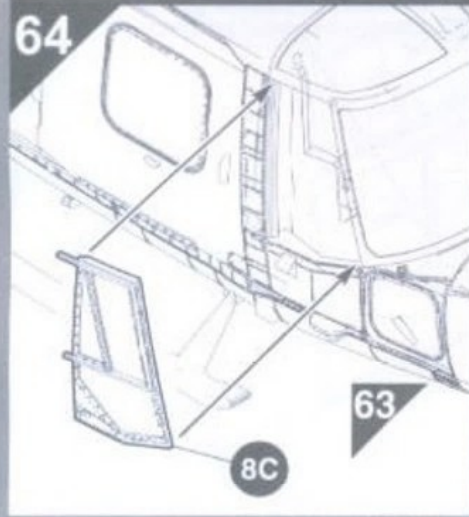
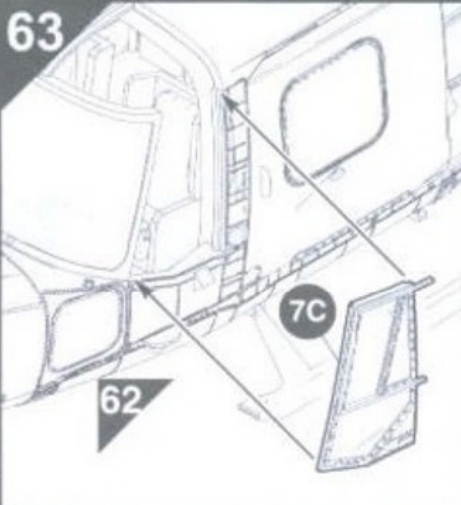
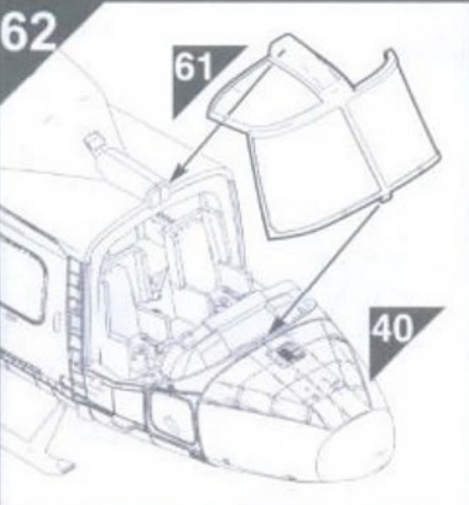
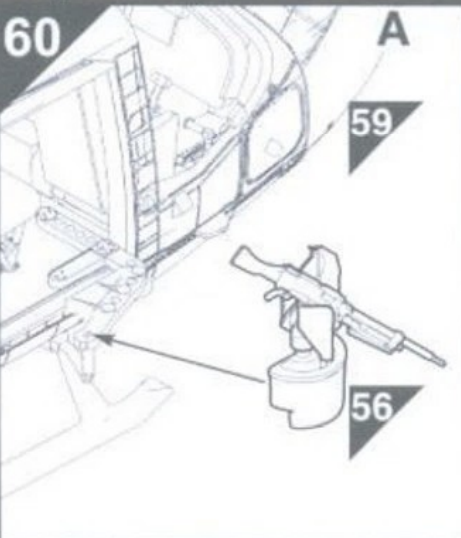
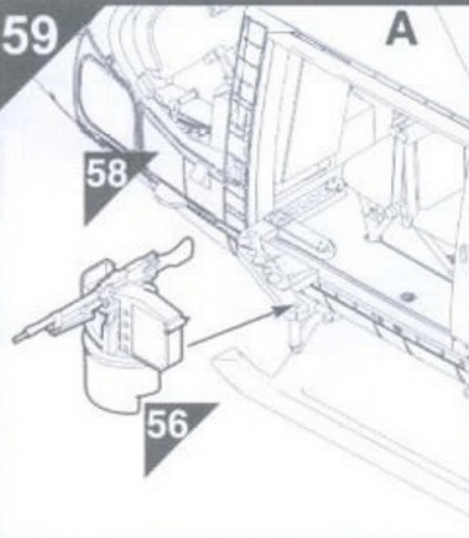
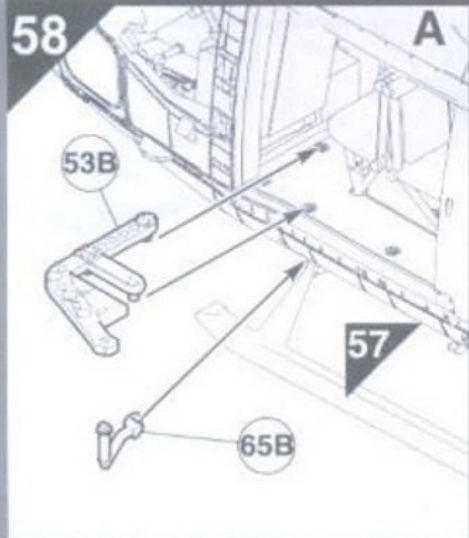
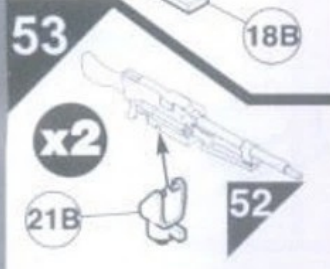
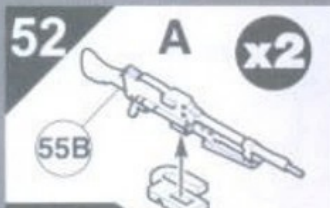



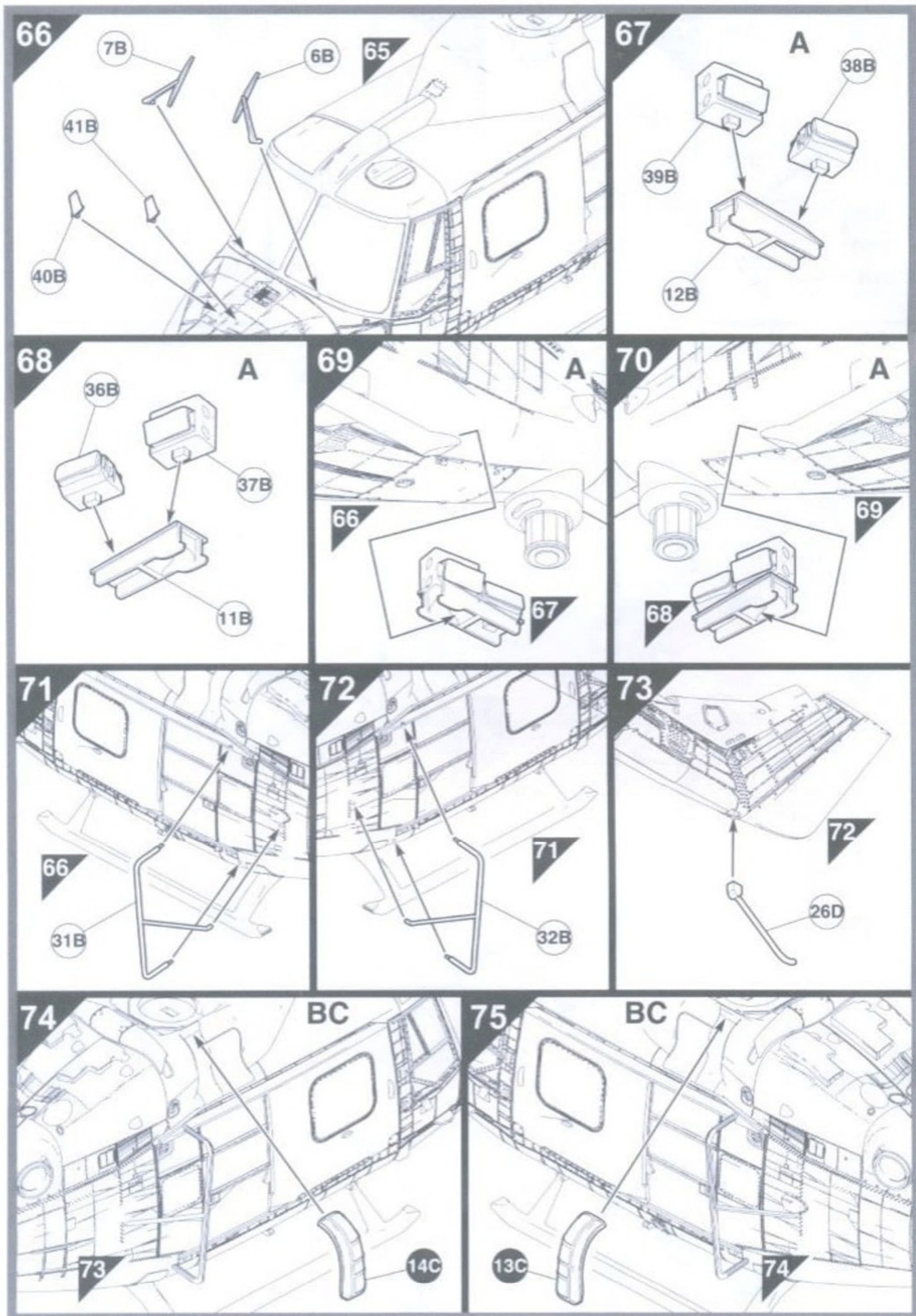



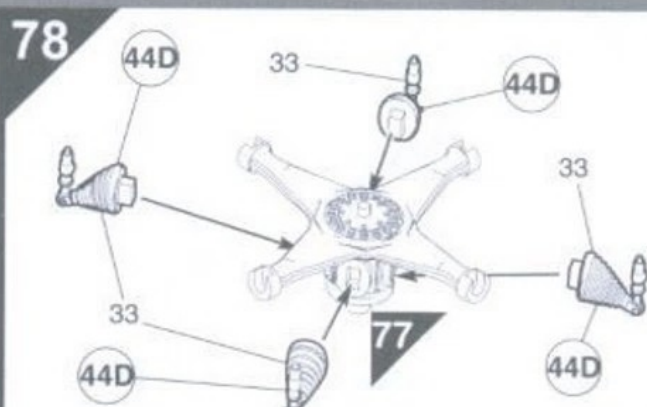
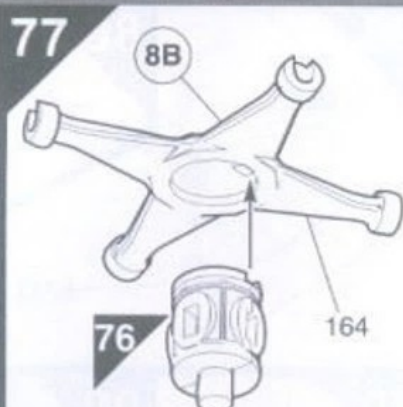

For rotors unfolded option, build steps 79 to 82 then go straight to step 93.  
For rotors folded option, miss out steps 79 to 82. Go straight to step 83.

Pour l'option rotor déplié, construire les étapes 79 à 82 puis aller directement à l'étape 93.

Pour l'option rotor plié, omettre les étapes 79 à 82. Aller directement à l'étape 83.

Für den Zusammenbau mit aufgeklappten Rotoren nach den Schritten 79 bis 82 verfahren und dann zu Schritt 93 weitergehen.

Für den Zusammenbau mit zusammengeklappten Rotoren die Schritte 79 bis 82

auslassen und zu Schritt 83 weitergeben.

Para la opción con palas de hélice desplegadas, monta los pasos 79 a 82 y a continuación ve directamente al paso 93.

Para la opción con palas de hélice plegadas, pasa por alto los pasos 79 a 82. Ve directamente al paso 83.

Om rotorerne ska vara ovikta bygger du steg 79 till 82 och går vidare till steg 93.

Om rotorerne ska vara vikta hoppar du över steg 79 till 82. Gå direkt till steg 83.

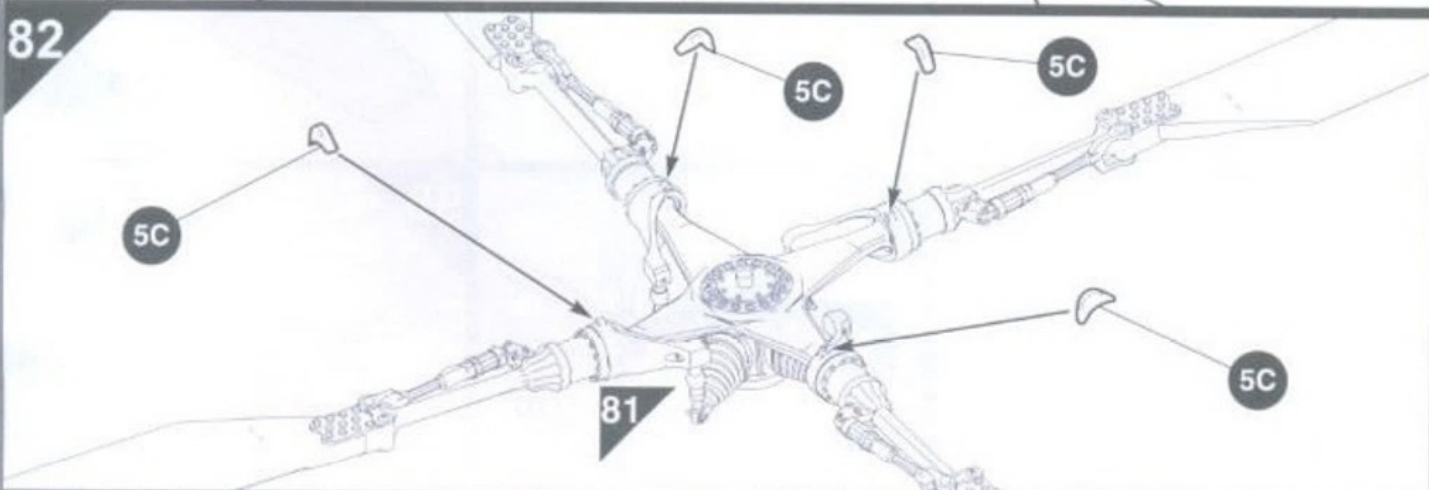
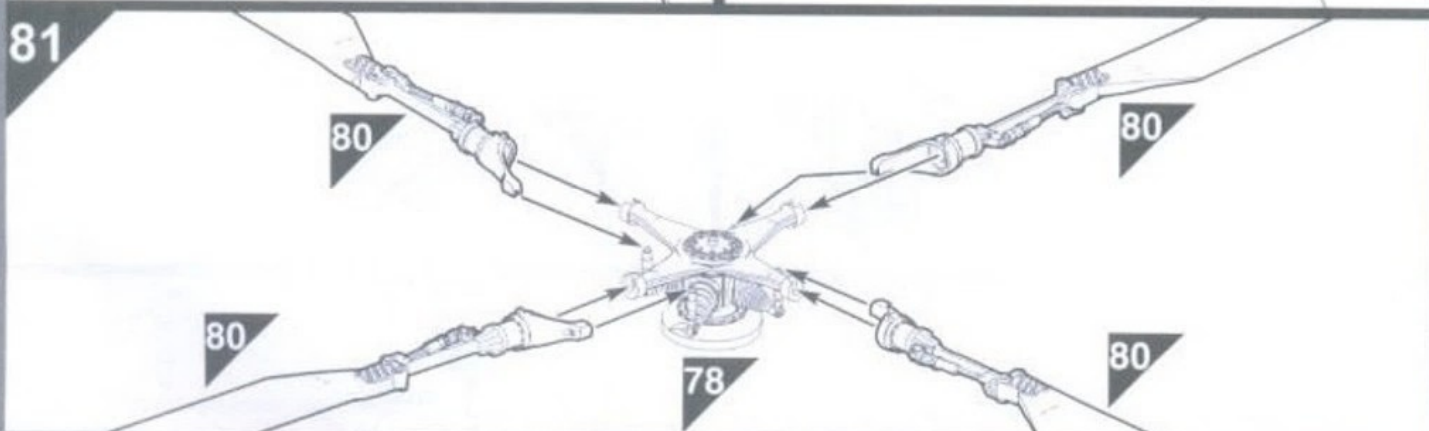
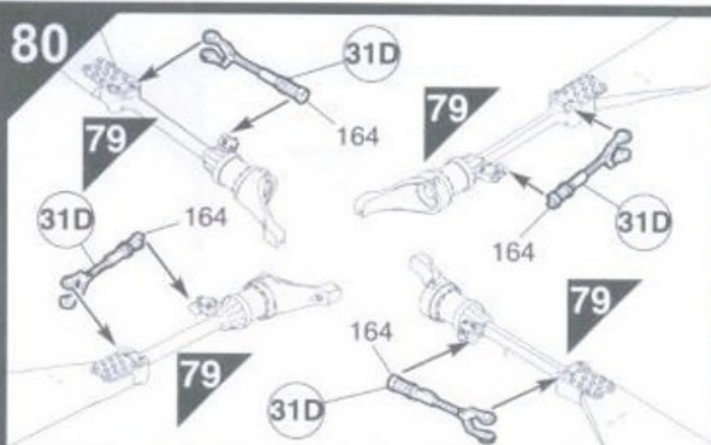
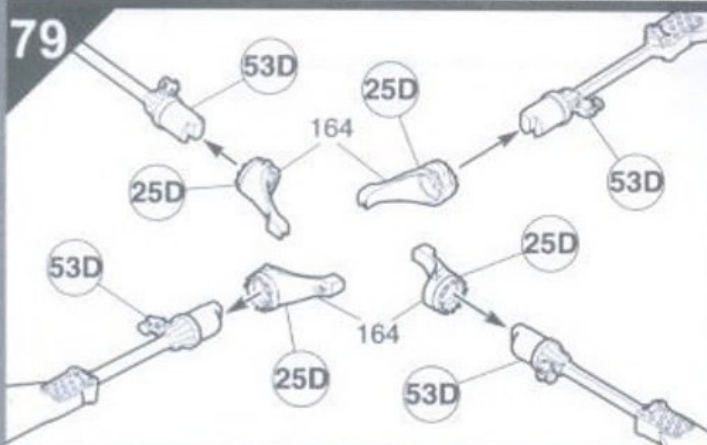



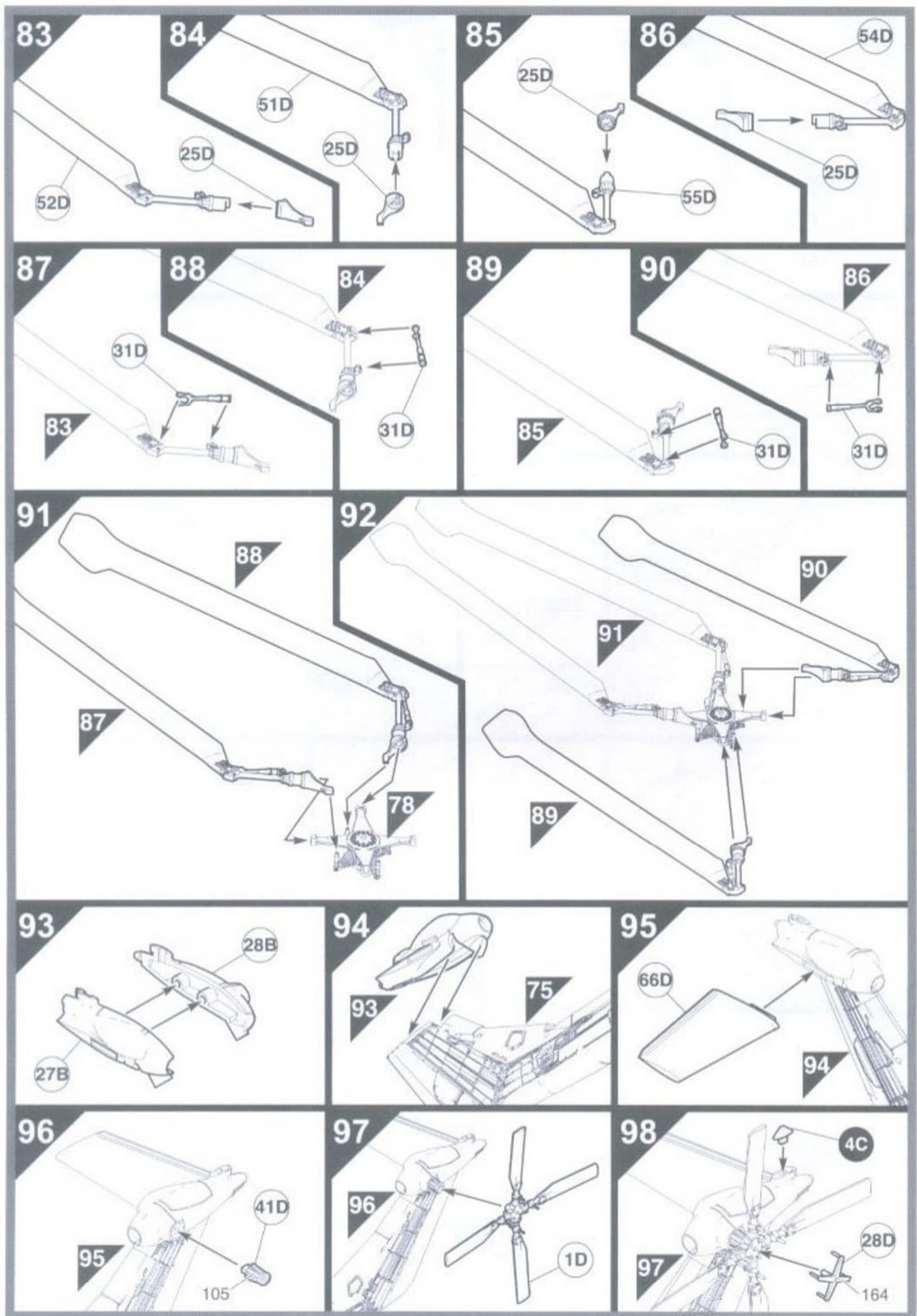



99

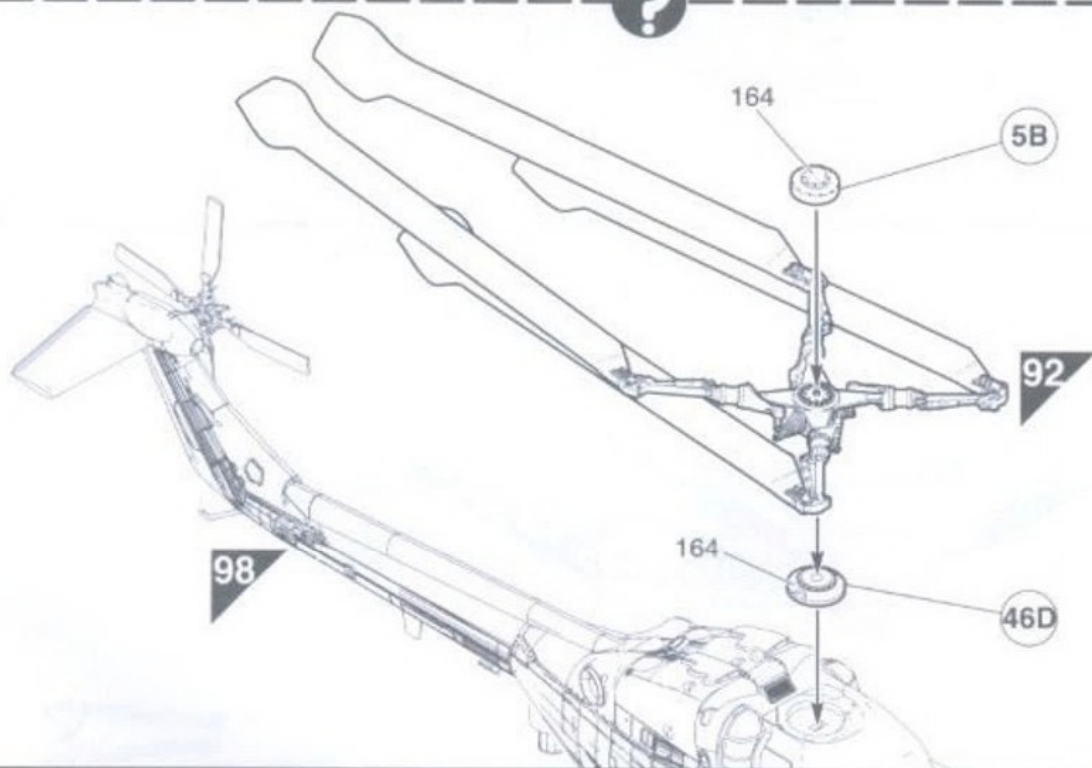
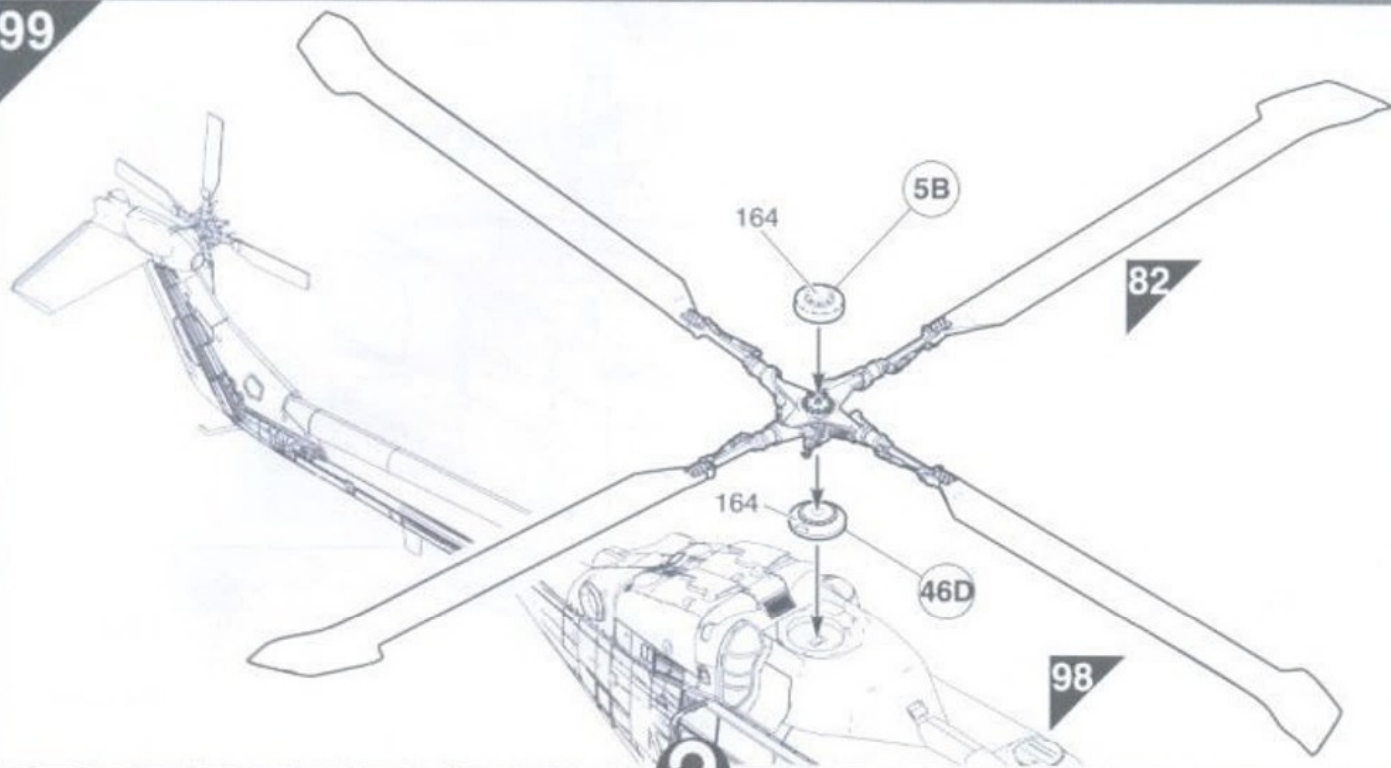

100

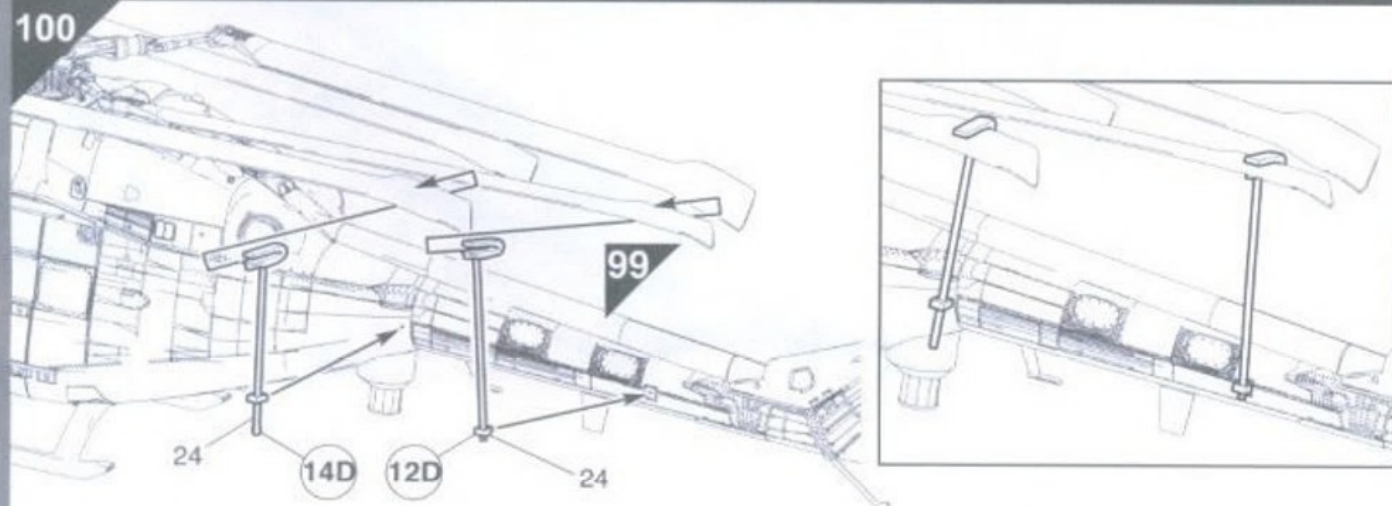



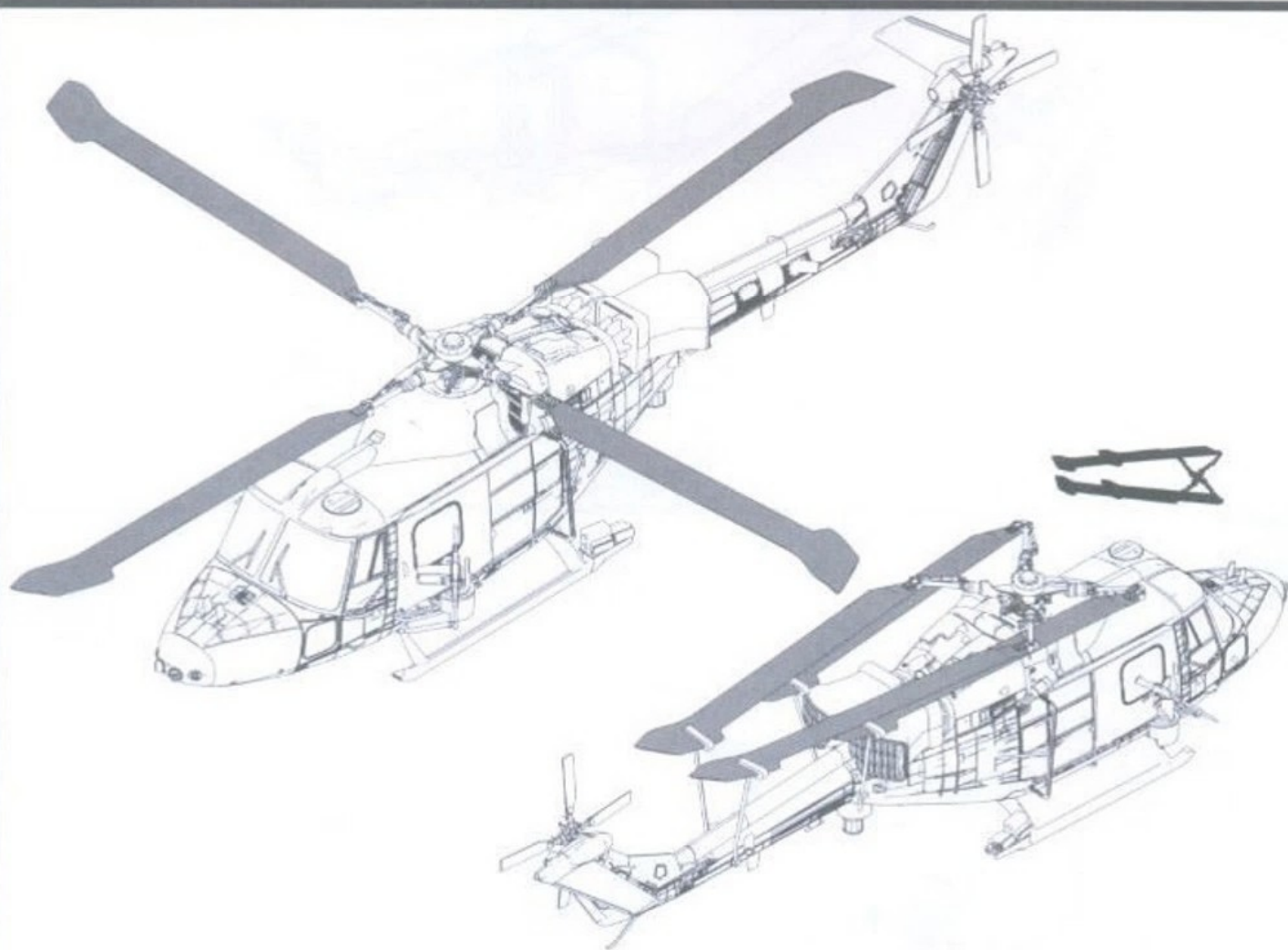
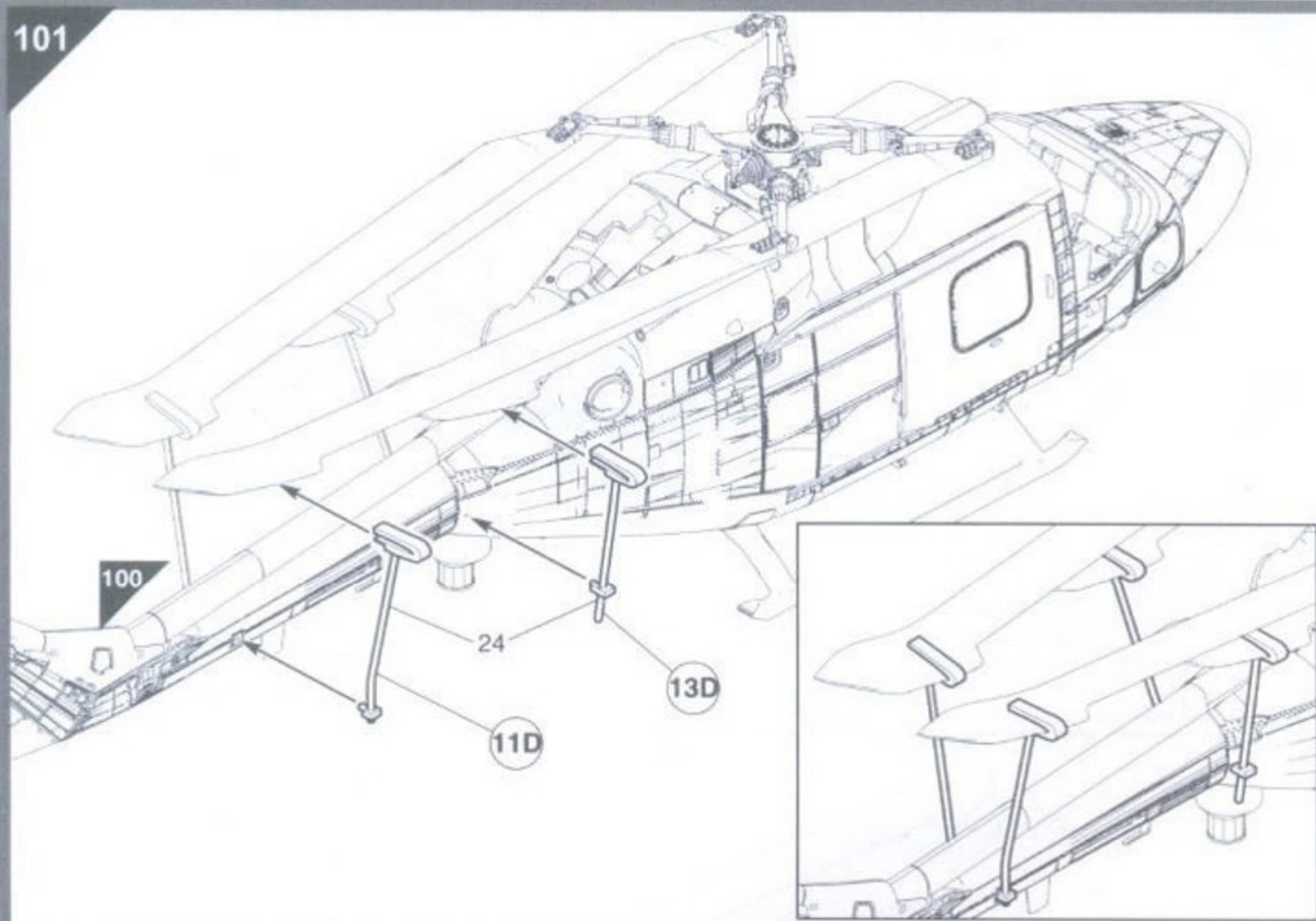



# A Westland Lynx AH-7

Army Air Corps, Afghanistan, 2006.

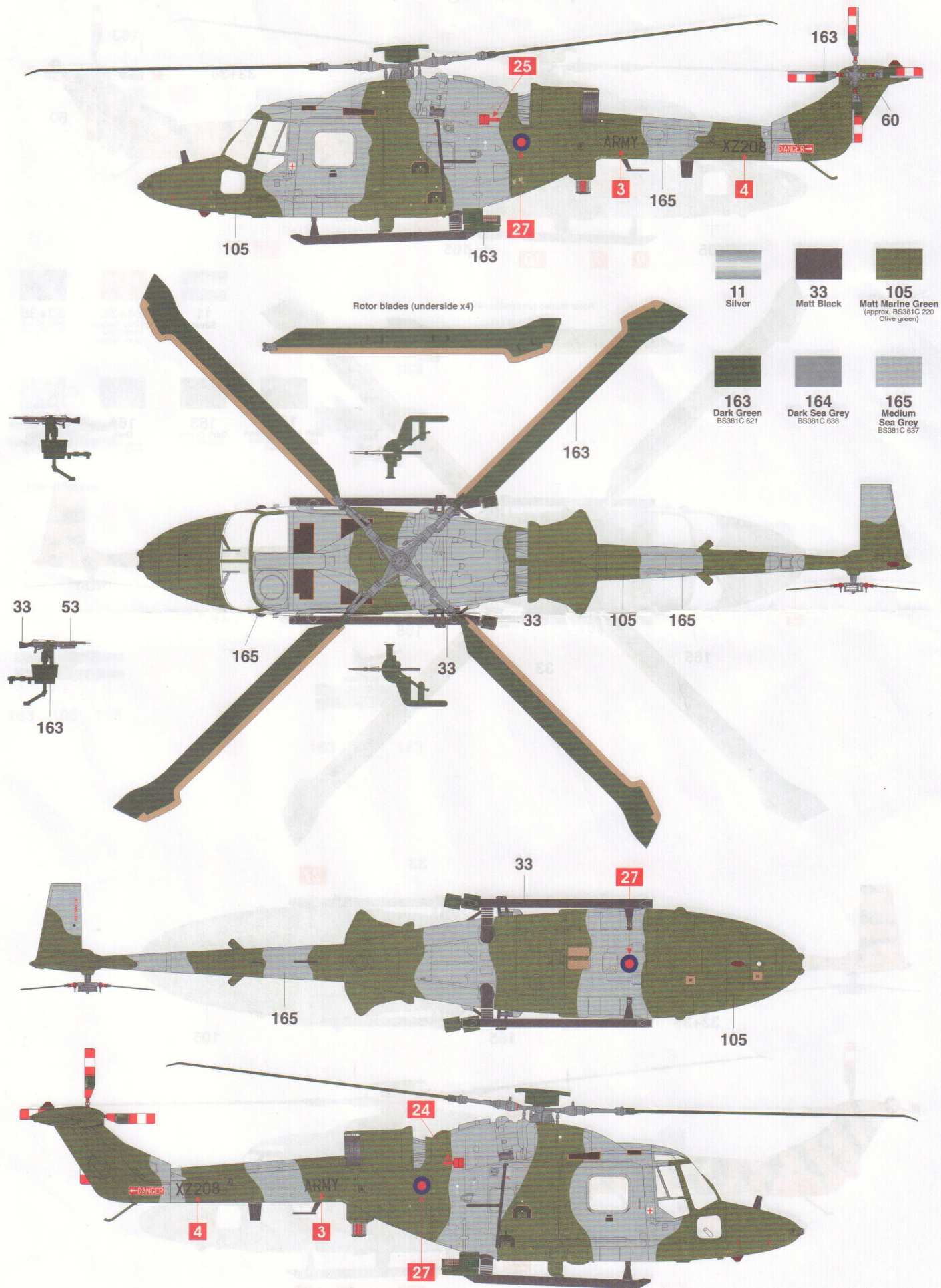

- |  |   |  |
|--|---|--|
|  |   |  |
| <b>11</b><br>Silver                    | <b>33</b><br>Matt Black                   | <b>105</b><br>Matt Marine Green<br>(approx. BS381C 229<br>Olive green) |
|  |   |  |
| <b>163</b><br>Dark Green<br>BS381C 621 | <b>164</b><br>Dark Sea Grey<br>BS381C 638 | <b>165</b><br>Medium<br>Sea Grey<br>BS381C 637                         |

Rotor blades (underside x4)

165

105

165

105

165



## B Westland Lynx AH-7

No. 671 Squadron, 2 (Training) Regiment, Army Air Corps, Middle Wallop, Hampshire, England, 2005.

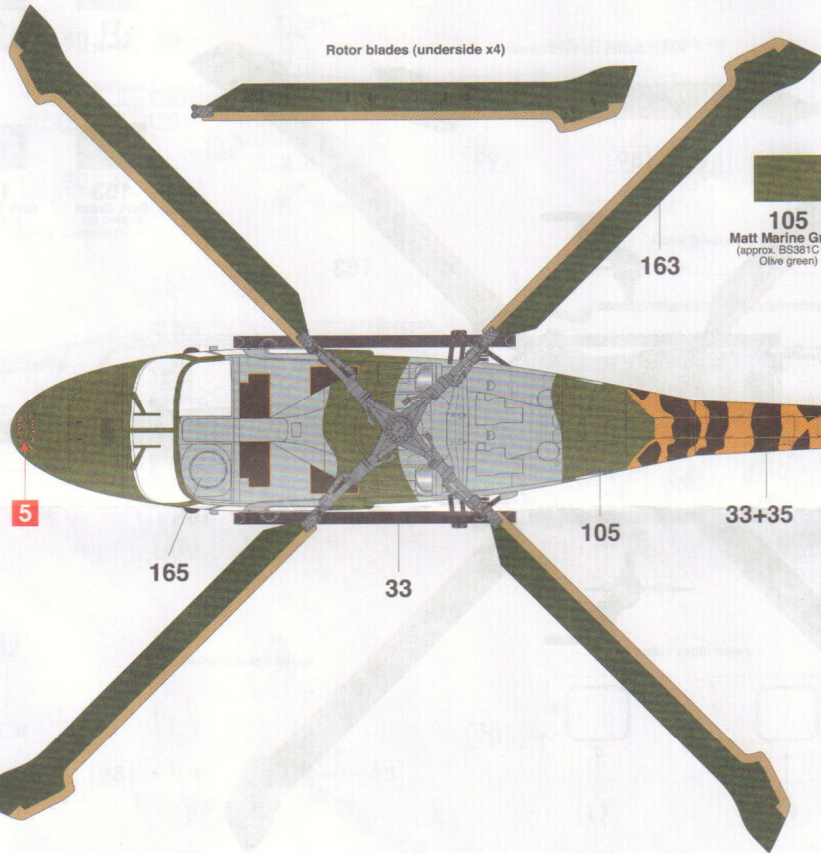

11 Silver	24+35 Trainer Yellow BS381C 356 + Gloss Varnish	33+35 Matt Black + Gloss Varnish
105 Matt Marine Green (approx. BS381C 220 Olive green)	163 Dark Green BS381C 621	164 Dark Sea Grey BS381C 636
		165 Medium Sea Grey BS381C 637

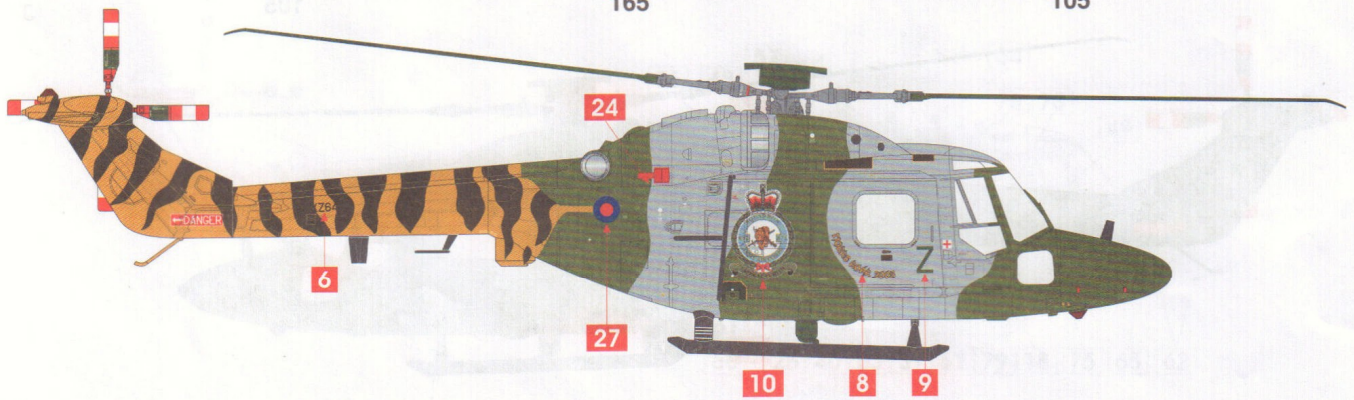
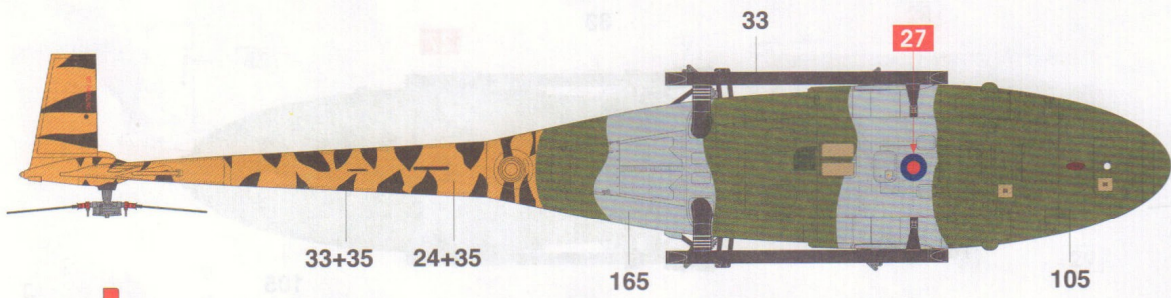



# © Westland Lynx AH-7

No. 847 Naval Air Squadron, 3 Commando Brigade/Royal Marines Armoured Support Group, Royal Naval Air Station Yeovilton, Somerset, England, 2005.

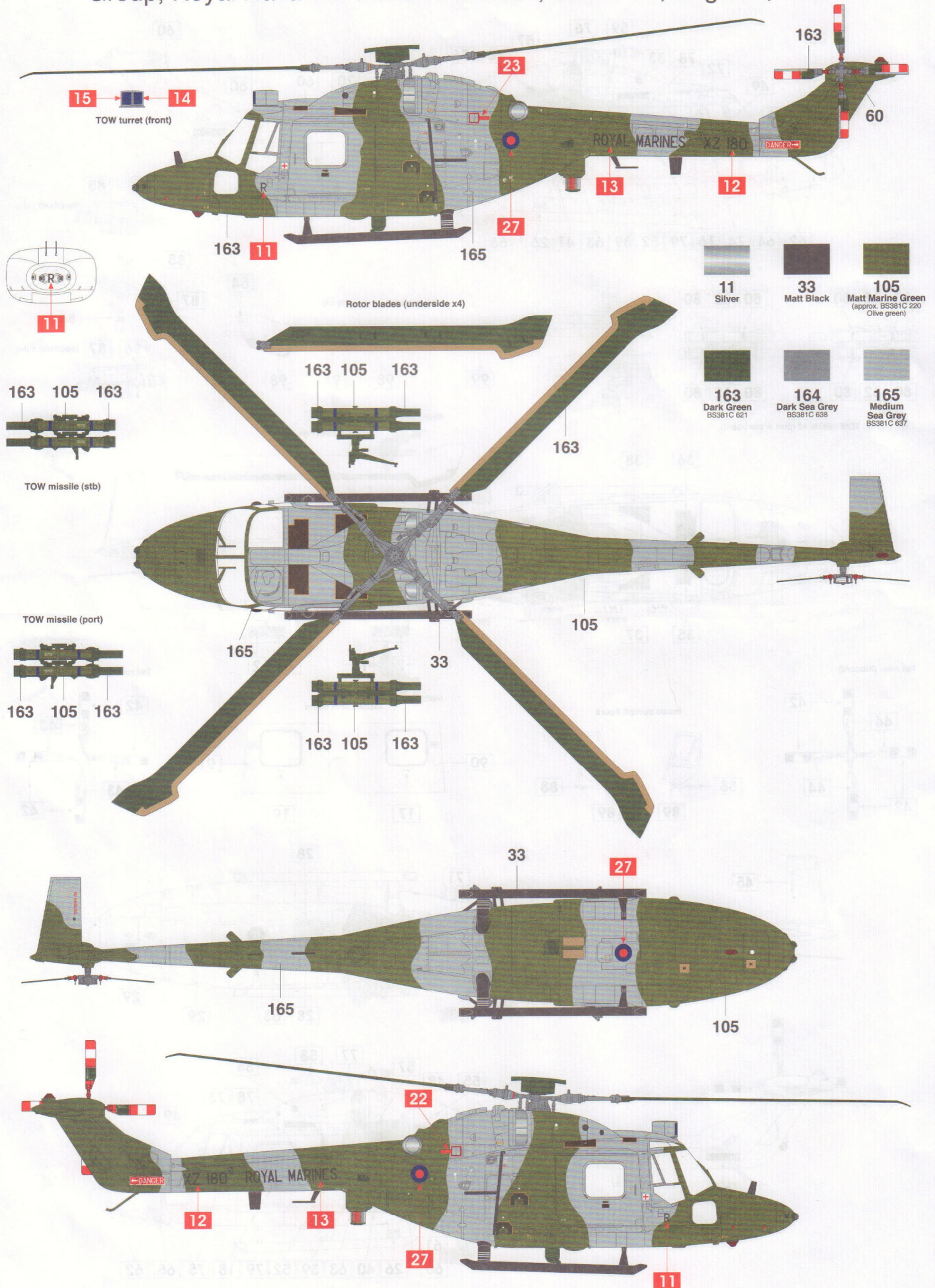



# Westland Lynx AH-7

## Position of stencil data

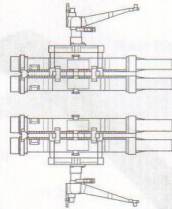
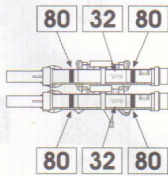
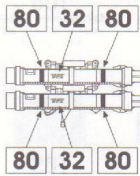
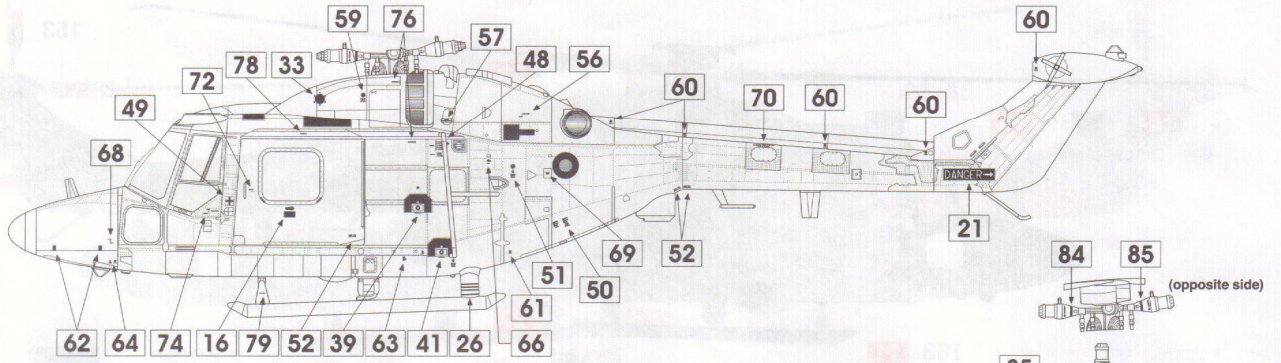

C TOW missile x2 (port & starboard)

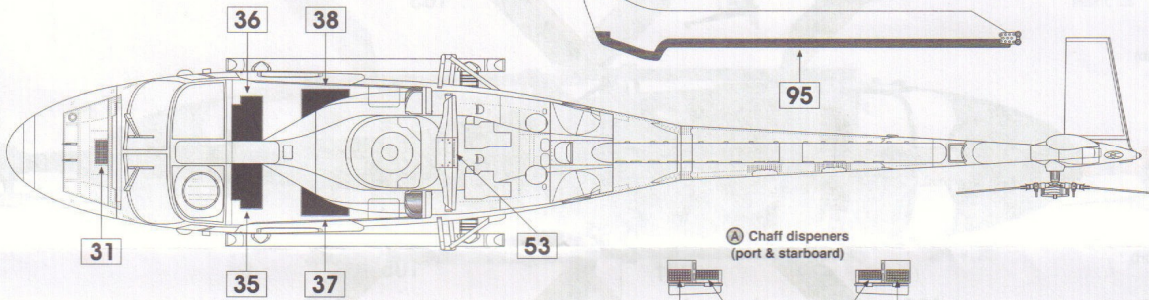
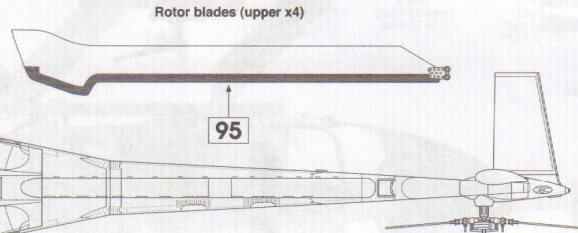
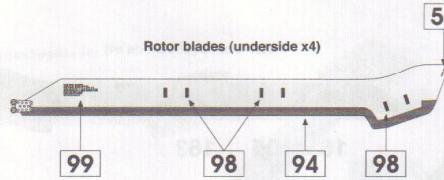

A Chaff dispensers (port & starboard)

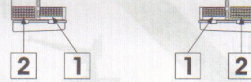

Tail rotor (inboard)

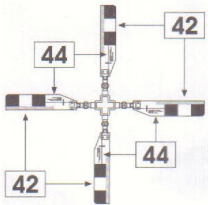

Inside cockpit doors

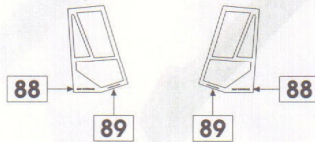

Inside cabin doors

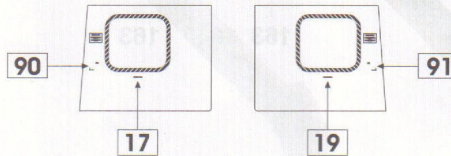

Tail rotor (outboard)

